

Surge Protection Type RTD input isolated safety barrier

PHD-11TZ-*1+ 1 input and 1 output
 PHD-12TZ-*11+ 1 input and 2 outputs

Input: Two-wire or three-wire RTD signal
 Output: 4~20mA

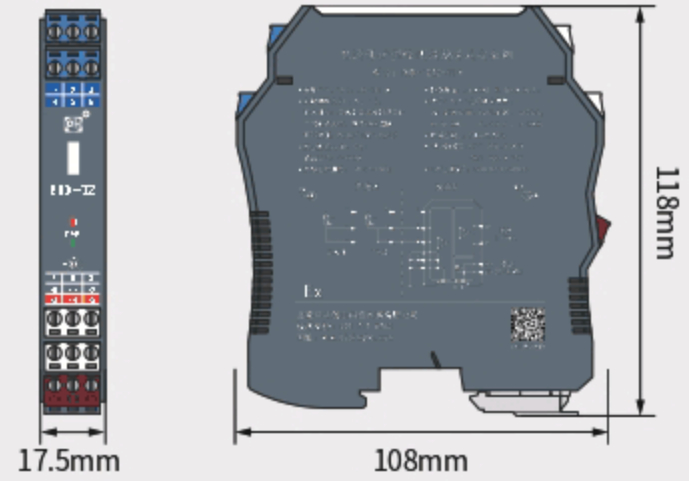

Overview

The RTD input isolation safety barrier with surge protection function can convert the two wire or three wire thermistor (RTD) signals in hazardous areas into 4~20mA current signals and output them to the safety zone. It can be intelligently configured, and the actual range of the thermal resistance can be set through computer software. It has the functions of wire breakage alarm and out of range alarm. This product requires independent power supply, with isolated power supply, input, and output terminals. ""*"" represents the input type of the thermistor, and the specific model is represented by a code (see "Input Signal Type and Range Table" for details).

Specifications

Input in hazardous area:

Input signal: Two wire or three wire thermistor signals (see "Input Signal Type and Range Table" for details)
 Input disconnection: The default "low alarm" can be modified to "high alarm" through configuration software
 Signal range: Corresponding measurement range of thermal resistance
 Measurement range: Users make their own configuration when ordering, and indicate it at the tail number or otherwise.

Safety side output:

Output signal: 4~20mA
 Output load capacity: 0~500Ω(customizable)

Surge protection features:

Nominal discharge current $I_n(8/20\mu s)$: 5kA
 Voltage protection level $U_p(8/20\mu s)$: 60V(line to line)
 Voltage protection level $U_p(8/20\mu s)$: 600V(line to ground)
 According to standards: GB/T18802.21-2016 (equivalent to IEC61643-21:2012)

Basic parameters:

Supply voltage: 20~35V DC
 Power consumption: When 24VDC power supply, 20mA output
 $\leq 40mA$ (PHD-11TZ-*1+)
 $\leq 70mA$ (PHD-12TZ-*11+)

LED indicator: Green: Power indicator

Low range alarm yellow light on, high range alarm red light on
 Output accuracy: Please refer to the "Input Signal Type and Range Table" for details

Response time: Reaching 90% of the final value within 300ms
 Temperature drift: 0.005%F.S/°C
 Temperature parameters: Working temperature: -20°C~+60°C
 Storage temperature: -40°C~+80°C

Relative humidity: 10%~95% RH no condensation

Insulation strength: Between intrinsically safe side and non-intrinsically safe side ($\geq 3000VAC/min$); between power supply and non-intrinsically safe side ($\geq 1500VAC/min$)

Insulation resistance: $\geq 100M\Omega$ (between input/output/power supply)
 EMC: According to IEC 61326-1(GB/T 18268), IEC 61326-3-1
 MTBF: 100000h

Wire requirements: Horizontal cutting surface $\geq 0.5mm^2$;
 Insulation strength $\geq 500W$

Applicable field equipments: Two wire or three wire thermistors
 G53, Cu50, Pt100, Pt1000, Ni1000

Installation place: Installed in a safe zone, it can be connected to intrinsic safety instruments in hazardous areas up to Zone 0, IIC, Zone 20, and IIIC

Schematic diagram

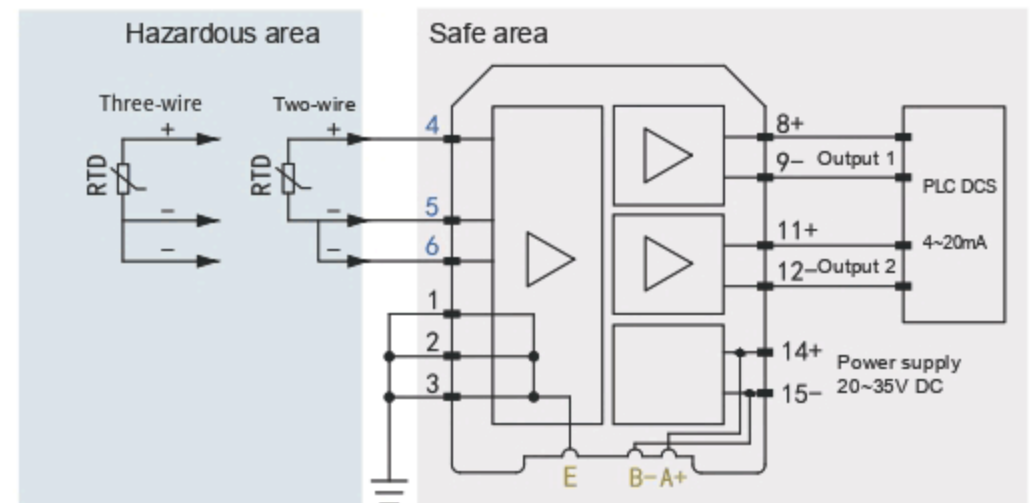

- Note: 1. PHD-11TZ - * 1+ does not include output part 2
 2. The power rail function is an optional function, and users need to specify the power supply method when placing an order
 The selection of power rail connectors can refer to page 89 of the "Annex"
 3. When inputting a three wire RTD, it is necessary to ensure that the three wires are of equal length as much as possible
 4. When inputting a two-wire RTD, safety barrier terminals 4 and 2 must be short circuited

Input signal type and range table

Code	Model	Measurement range	Minimum range	Conversion accuracy
1	G53	-50~150°C	20°C	0.2°C/0.1%
2	Cu50	-50~150°C	20°C	0.2°C/0.1%
4	Pt100	-200~850°C	20°C	0.2°C/0.1%
6	Pt1000	-200~850°C	20°C	0.2°C/0.1%
7	Ni1000	-60~250°C	20°C	0.2°C/0.1%

Intrinsically safe certification

Explosion proof mark: [Ex ia Ga] IIC [Ex ia Da] IIIC
 Explosion-proof standard: GB/T 3836.1-2021 GB/T 3836.4-2021
 Terminals 4-6, 5-6 U_m : 250V AC/DC $U_o=8.4V$ DC $I_o=31mA$
 $P_o=65.1mW$ $C_o=4.8\mu F$ $L_o=20mH$
 Certification body: CQST(China National Quality Supervision and Test Centre for Explosion Protected Electrical Products)
 Shanghai lightning protection products testing center