

Rotor 3-ways Mixing valves

Data sheet

ZL-2142

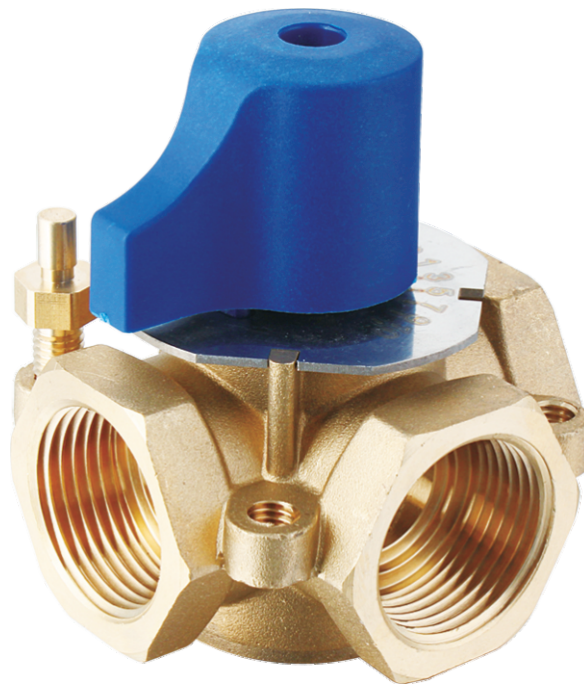

Description

Rotor mixing valves are used in heating and cooling systems to the typical purpose of mixing and distributing fluid. The overall stroke is realised by a 90 rotation of the rotor. The valves can be controlled manually or automatically, by installing a servomotor controlled in its turn by a thermostat or by a climatic controller. On the other hand, 3-way valves can be used either as mixing or diverter devices (e.g. as priority valves in systems for the production of domestic hot water). These rotor mixing valves are constructed entirely in brass (body and rotor). With respect to classic cast iron valves, they offer many advantages, such as low risk of jamming between rotor and body when the rotor is not used for a long period, smaller dimensions and lower weight at the same sturdiness.



Technical Specifications

Maximum working pressure	10bar
Maximum working temperature	120°C
Min operating torque	1N.m
Thread specification	3/4", 1", 1 1/4"(ISO228-1)

Characteristic components

No.	Components	Materials
1	Valve body	Brass
2	Valve cap	Brass
3	Valve plug	Brass
4	Graduated plate	SUS304
5	Split baffle ring	SUS304
6	Hand wheel	PA
7	lock screw	A3
8	Seals	EPDM
9	locating rod	Brass

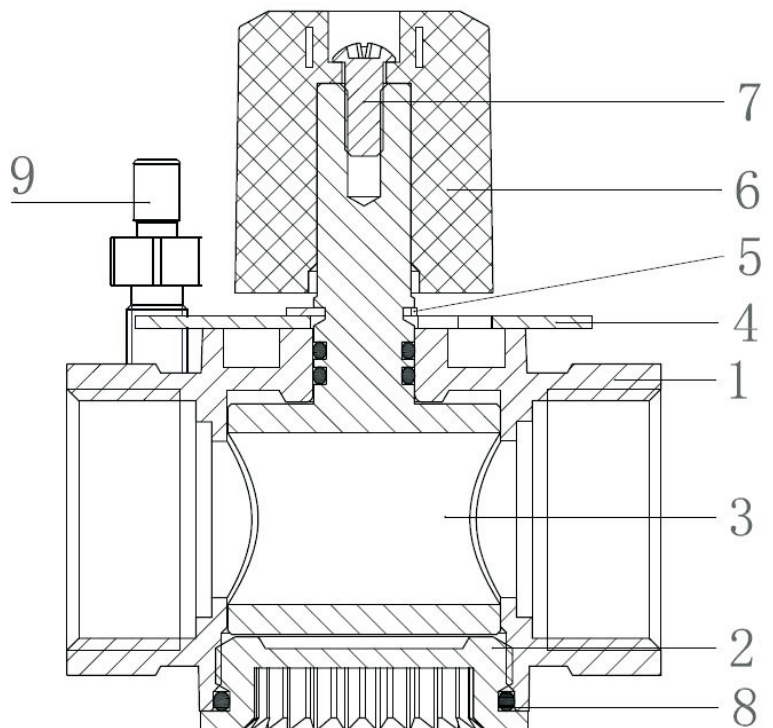

Dimensions

Code	A	B	C	D	E	G
ZL2142202020	72	92	73	46	6	3/4"
ZL2142252525	77	92	73	46	6	1"
ZL2142323232	86	92	73	46	6	1 1/4"

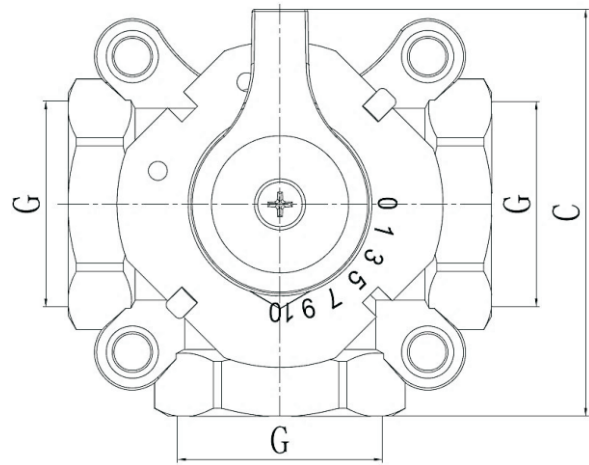
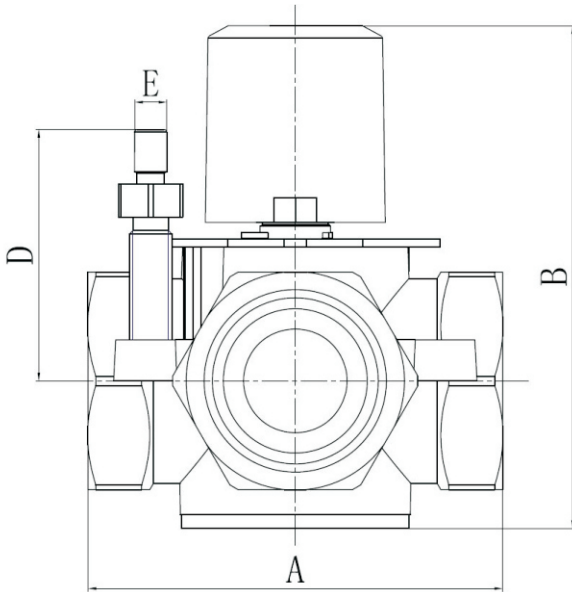

Installation

The three-way valves can be used for all standard mixing and distribution applications. Depending on the assembling and on the flow direction, change the position of the graduated plate, or rotate it, in order to have a counterclockwise graduation. Notes: The plate can be moved after removing the split baffle ring on it, beneath the adjustment knob.

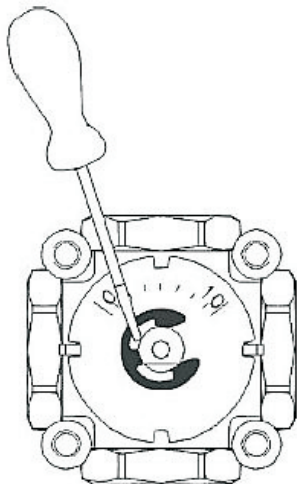

Mixing

Distribution

