

Anti-freeze valve  
ZL-7201

Contact  
Email: [sales2@bzvalve.com](mailto:sales2@bzvalve.com)

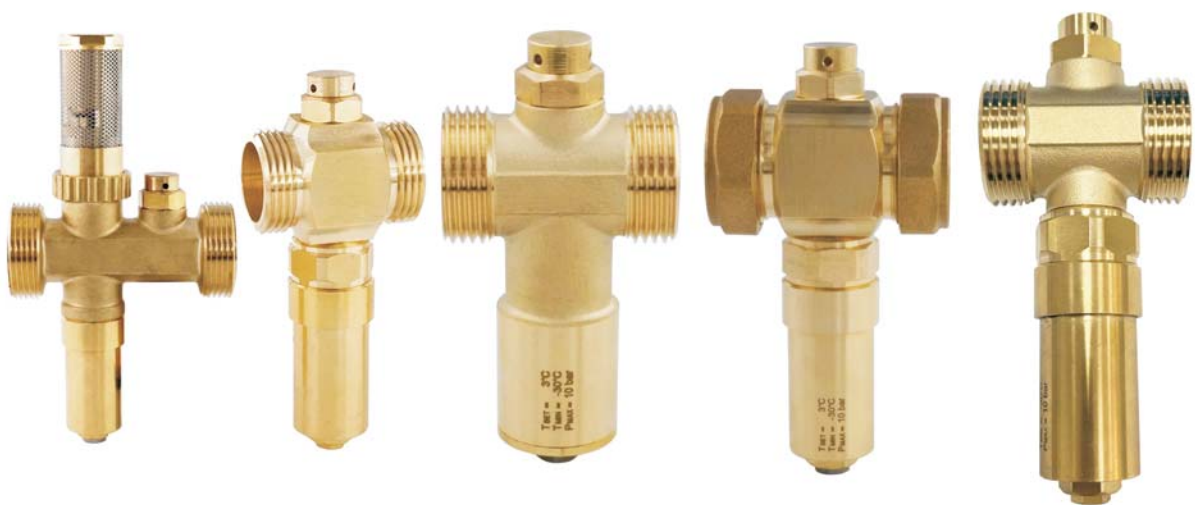

## DESCRIPTION



The antifreeze valve allows the circuit medium to be drained when its temperature reaches an average value of 3 °C. This prevents ice forming in the circuit of a system, generally with a heat pump, avoiding potential damage to the machine and to the pipes.

The version with the air sensor allows the system to work in cooling mode, even when the water temperature is approaching 3 °C. In these conditions the air sensor cuts in to prevent water drainage.

## Product range

- Antifreeze valve with threaded connections sizes DN 25 (1"), DN 32 (1 1/4") and DN 40 (1 1/2")
- Antifreeze valve with connections for copper pipe sizes DN 25 (Ø 28)
- Antifreeze valve with air sensor, threaded connections sizes DN 25 (1") and DN 32 (1 1/4")

## Technical specifications

### Materials

Body: brass EN 12165 CW617N

Springs: stainless steel

Seals: EPDM

Connections: G 1" (ISO 228-1)  
G 1 1/4" (ISO 228-1)  
G 1 1/2" (ISO 228-1)  
Ø 28 mm for copper pipe

### Performance

Medium: water

Maximum working pressure: 10 bar

Working temperature range: 5 bar

Ambient temperature range: 0–65 °C

Medium temperature (opening): -30–60 °C

Medium temperature (closing): 3 °C

Enabling of antifreeze function with outside air temperature: 4 °C

Accuracy: < 5 °C

Kv (straight path): 1 °C

55 m<sup>3</sup>/h

70 m<sup>3</sup>/h

Tightening torque: 72 m<sup>3</sup>/h

64 m<sup>3</sup>/h

80 N·m

### Discharge flow rate

P(bar)	T outside(°C)	Flow rate(l/h)
3	-5	0.5
	-20	1

Test conditions:

- straight pipe ( 12 mm, length 1 m) exposed to the outside;
- water temperature inside building 18 °C.

## Dimensions

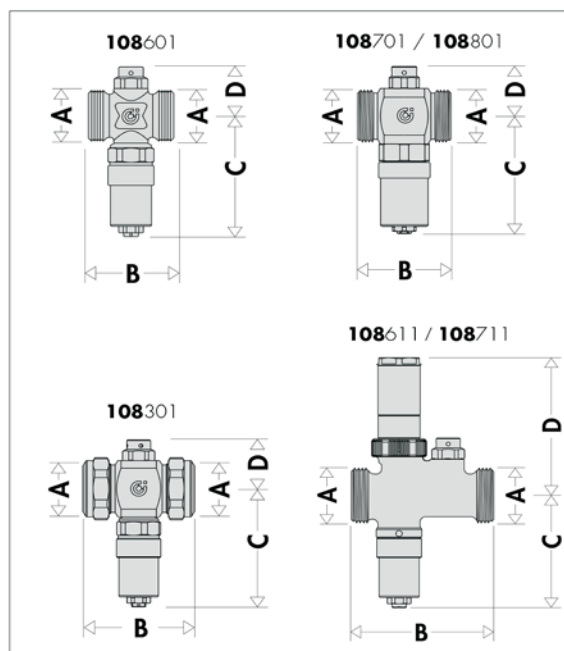

A	B	C	D
1"	52	79	32
1 1/4"	59	83	36
1 1/2"	62	83	36
28	71	80	33
1"	81	74	91
1 1/4"	91	74	91

### Characteristic components

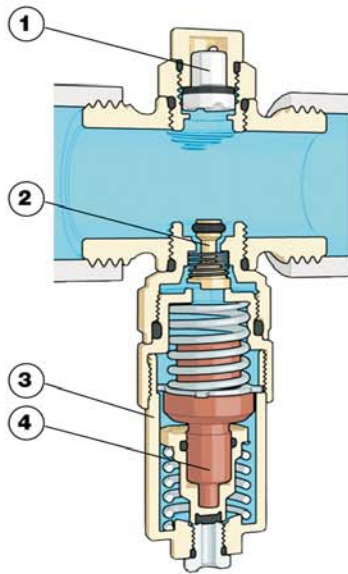

#### Antifreeze valve

1. Vacuum breaker
2. Automatic shut-off cock
3. Water temperature sensor cartridge
4. Water temperature sensor

### Operating principle

#### Antifreeze valve

The antifreeze valve allows drainage of the medium in the circuit when the circuit temperature reaches a value of 3°C.

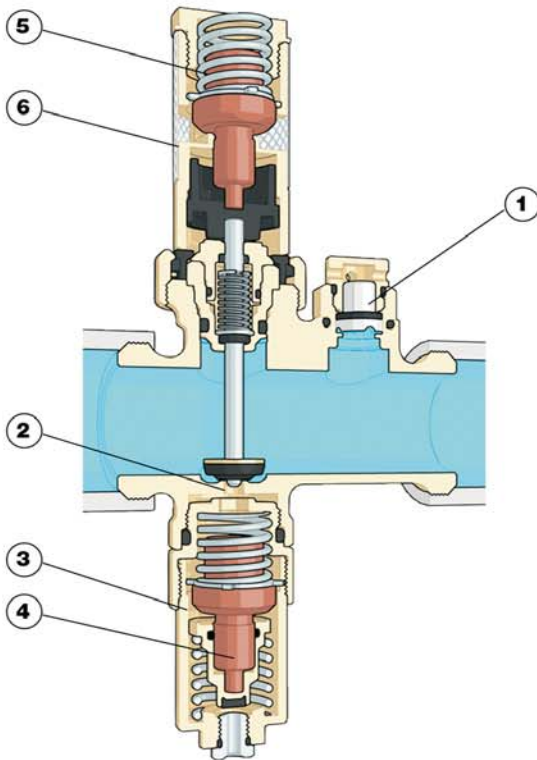
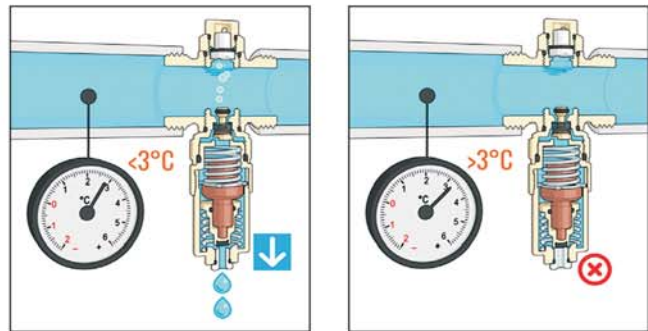
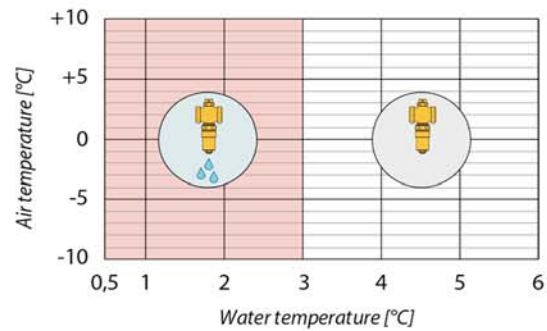

#### Antifreeze valve with air sensor

1. Vacuum breaker
2. Air temperature sensor obturator
3. Water temperature sensor cartridge
4. Water temperature sensor
5. Air temperature sensor
6. Air temperature sensor cartridge

#### Antifreeze valve with air sensor

The antifreeze valve allows drainage of the medium in the circuit when the circuit temperature reaches a value of 3°C. In outside temperature conditions over 5°C, antifreeze valve cut-in is inhibited by the air temperature sensor. This prevents the valve from cutting in during operation in cooling mode during the summer.

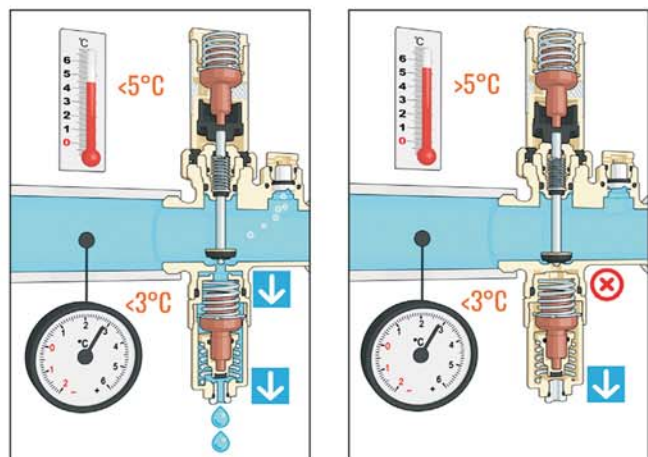
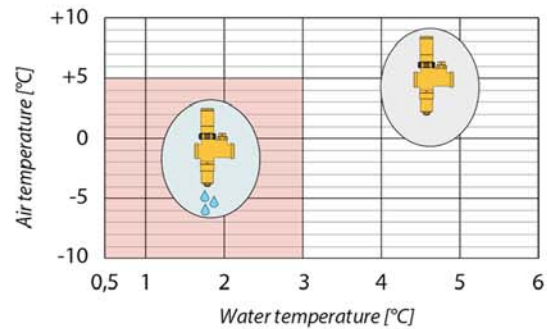

### Operating phases

Winter operation in heating mode

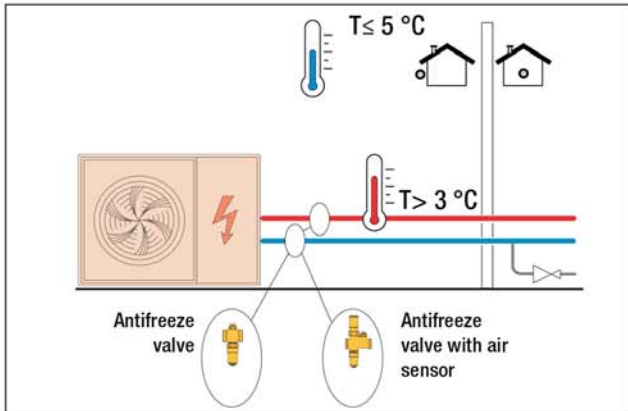

Winter operation in the event of electric supply failure

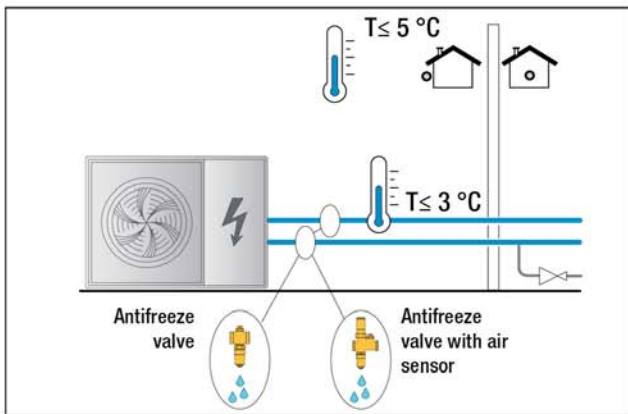

Summer operation in cooling mode

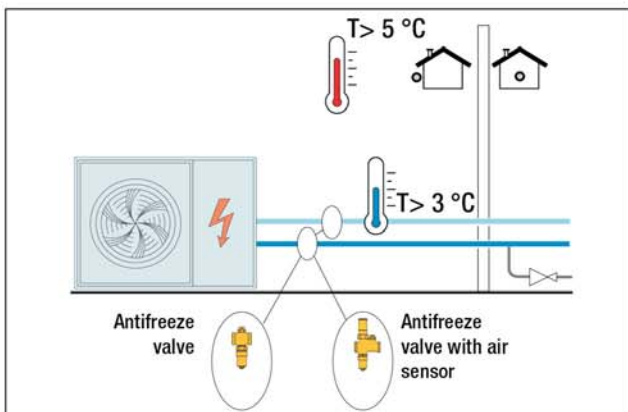
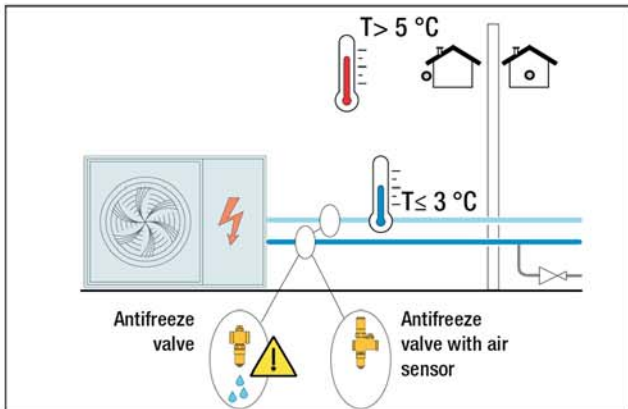

### Installation

The device must only be installed in a vertical position, with the outlet facing downwards, to allow the drained water to flow out properly and free from obstructions. The antifreeze valves must be installed outdoors, where the lowest temperatures can be reached if the heat pump is locked. The antifreeze valves must be positioned well away from sources of heat in order to keep them working properly. It is recommended to install the antifreeze valves on both pipes (flow and return). Otherwise, water may be left in one pipe which could then freeze.

**We recommend always keeping the system pressurised, even while draining, to ensure the antifreeze device works properly.**

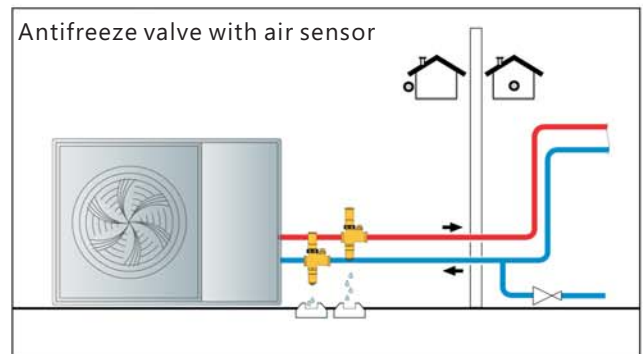
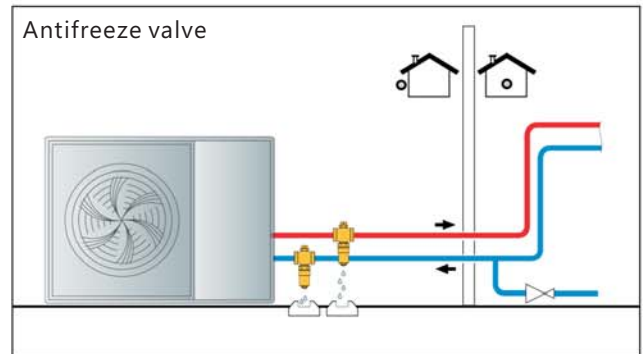

Leave at least 15 cm clearance from the ground (fig. A) to prevent the block of ice which may form below from stopping water from draining from the valve.

Route the drain to a suitable collection point.

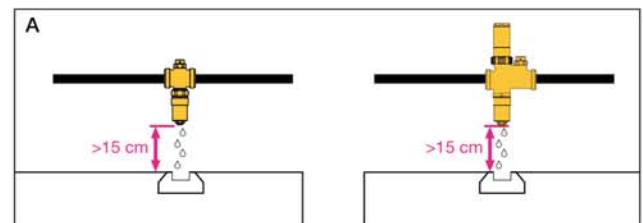

Keep a distance of at least 10 cm between the antifreeze valves (fig. B) and 20 cm between the antifreeze valves and the air sensor (fig. C).

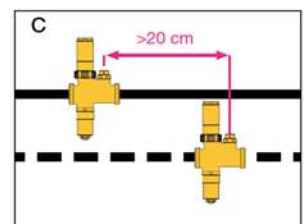
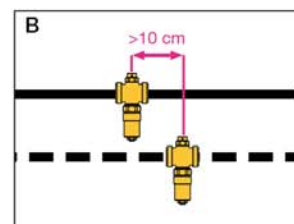

The antifreeze valve must be free of insulation for the system to work properly.

When installed outdoors, the antifreeze valve must be protected from rain, snow and direct sunlight.

### Presence of traps

Do not make any trap connections. If the shape of the connection pipe has the potential to create a trap effect (as shown in the following figure), drainage is inhibited and frost protection will no longer be guaranteed.

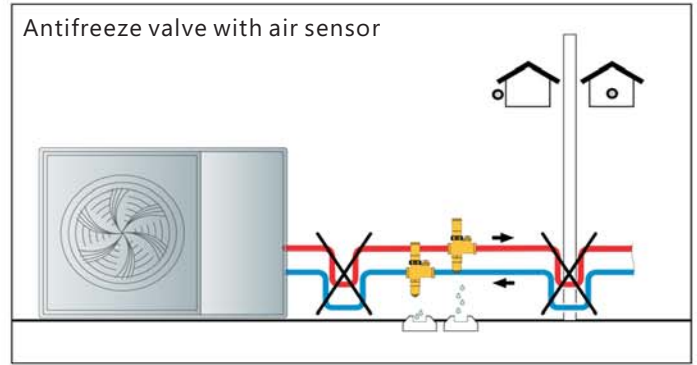
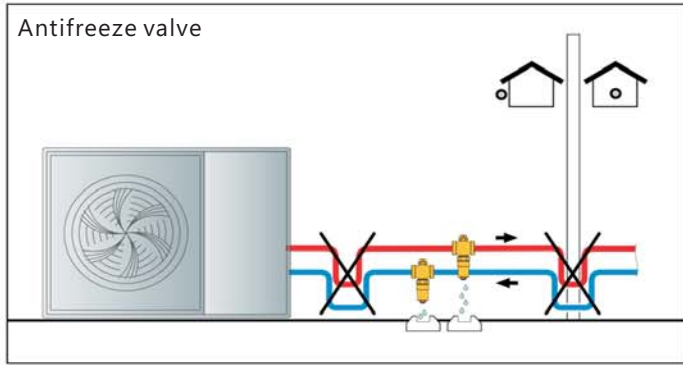

### Antifreeze valve maintenance

#### 1A. Vacuum breaker

The vacuum breaker can be replaced with spare part code R0000994

#### 2A. Water sensor cartridge

An automatic shut-off cock prevents the water from draining while the cartridge is being replaced, thereby keeping the system pressurised.

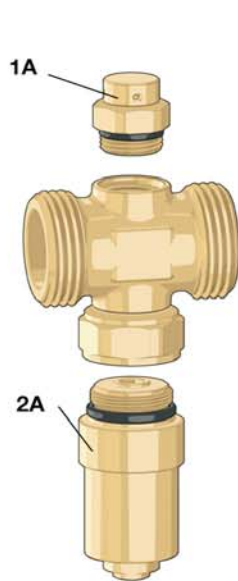

Antifreeze valve

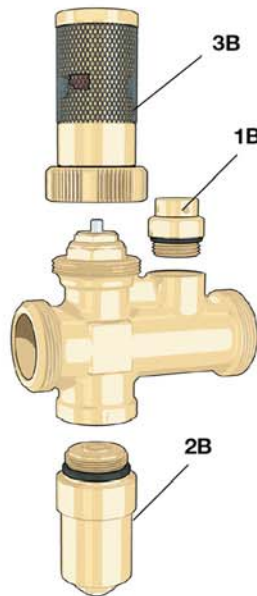

Antifreeze valve with air sensor

### Antifreeze valve with air sensor maintenance

#### 1B. Vacuum breaker

Only replace the cartridge when the outside air temperature > 5 °C. Otherwise, isolate the system using shut-off valves.

#### 3B. Air sensor cartridge

## SPECIFICATION SUMMARY

Antifreeze valve.	(ISO 228-1) (from G 1" to G 1 1/2").
Threaded G 1" M connections	
Brass body. Maximum working pressure	10 bar.
Working temperature range	0–65 °C.
Ambient temperature range: -30–60 °C.	
Water temperature for opening drain:	3 °C.
Water temperature for closing drain:	4 °C.
<hr/>	
Antifreeze valve.	Ø 28 copper pipe. Brass body.
With fittings for	10 bar.
Maximum working pressure	0–65 °C.
Working temperature range	-30–60 °C.
Ambient temperature range:	3 °C.
Water temperature for opening drain:	4 °C.
Water temperature for closing drain:	
<hr/>	
Antifreeze valve with air sensor.	(ISO 228-1) (from G 1" to G 1 1/4").
Threaded G 1" M connections	
Brass body. Maximum working pressure	5 bar.
Working temperature range	0–65 °C.
Ambient temperature range:	-30–60 °C.
Water temperature for opening drain:	3 °C.
Water temperature for closing drain:	4 °C.
Enabling of antifreeze function with outside air temperature	≤ 5 °C.