

Programmable Logic Controller C4374

User Manual

V1.0

C Series - Programmable Logic Controller



Odot Automation System Co., Ltd.

Copyright ©2024 Odot Automation all rights reserved

Legal Notices

The Odor Automation brand and any trademarks of Odor Automation System Co., Ltd. (hereinafter referred to as "Odor Automation") and its affiliated companies mentioned in this guide are the properties of Sichuan Odor Automation or its affiliated companies. All other brands are trademarks of their respective owners. This guide and its contents are protected by applicable copyright laws and are only for reference use. Without the prior written permission of Odor Automation, no part of this guide shall be reproduced or disseminated in any form or by any means (electronic, mechanical, photocopying, recording or otherwise) for any purpose. Odor Automation has not granted any rights or licenses for the act of using this guide or its contents for commercial purposes, except for a non-exclusive personal license for consultation on an "as-is" basis. The products and equipment of Odor Automation should be installed, operated, maintained and serviced by qualified personnel. Since standards, specifications and designs may change from time to time, the information contained in this guide may be changed at any time without further notice. To the extent permitted by applicable laws, Odor Automation and its affiliated companies will not assume any liability or obligation for any errors or omissions in the information content of this material or for the consequences caused or arising from the use of the information contained herein. As a member of a responsible and inclusive enterprise, we will update the content containing non-inclusive terms. However, before we complete the update process, our content may still contain standardized industry terms that customers may consider inappropriate. Copyright © 2024 Odor Automation. All rights reserved.

Safety Information

Important Information

Before attempting to install, operate, repair, or maintain the device, please read the instructions below carefully and familiarize yourself with the device by reviewing it. The following specific information may appear elsewhere in text or on the device to alert the user to potential hazards or to draw attention to information about clarifying or simplifying a process. If the device is used in a manner not specified by the manufacturer, the protection provided by the device may be voided.

DANGER

DANGER INDICATES A DANGEROUS SITUATION THAT, IF NOT AVOIDED, COULD RESULT IN SERIOUS BODILY INJURY OR EVEN DEATH.

WARNING

WARNINGS INDICATE DANGEROUS SITUATIONS THAT, IF NOT AVOIDED, COULD RESULT IN SERIOUS PERSONAL INJURY OR EVEN DEATH.

CAUTION

CAUTION INDICATES A DANGEROUS SITUATION THAT, IF NOT AVOIDED, COULD RESULT IN MINOR OR MODERATE PERSONAL INJURY OR EVEN DEATH.

Note

Note is used to indicate hazards that are not related to personal injury.

Please note

The installation, operation, repair and maintenance of electrical equipment is restricted to qualified personnel. Odot Automation does not assume any consequences arising from the use of this information.

A qualified person is a person who has the skills and knowledge related to the manufacture and operation of electrical equipment and its installation, and who has been trained in safety to detect and avoid the associated hazards.

Personnel qualifications

Only those who are properly trained, familiar with, and understand the contents of this manual and all other relevant product documentation are authorized to use this product.

Qualified personnel must be able to identify possible hazards, usually from mechanical, electrical or electronic equipment, arising from the setting of parameters and the modification of parameter values. Qualified personnel must be familiar with the standards, regulations and regulations designed to prevent industrial accidents and must comply with them when designing and building systems.

Intended Use

The products described in or referred to in this document, together with their software, accessories and options, are expansion modules designed for industrial use and should be used in accordance with the relevant instructions, instructions, examples, and safety instructions in this document and other supporting documents.

The use of this product must comply with all applicable safety laws and regulations, specified requirements and technical parameters.

Given the planned application, you must conduct a risk assessment before using this product. Appropriate safety-related measures must be taken based on the results of the assessment.

Since this product should be used as an integral part of an overall machine or process, personnel safety must be ensured through the design of the entire system.

This product must be used with the specified cables and accessories. Please use only original parts and original replacement parts.

Any use other than those expressly permitted is prohibited and may result in unintended harm.

Cyber security tips

A. Use controllers and devices only in protected environments to minimize network exposure and ensure that they cannot be accessed from the

outside.

B. Use firewalls to protect the control system network and separate it from the rest of the network.

C. If remote access is required, use a VPN (Virtual Private Network) tunnel.

D. Restrict access to development and control systems through physical means, operating system capabilities, etc.

E. Protect development and control systems with the latest virus detection solutions.

About this manual

Document scope

This guide describes the design parameters of the C4374 programmable controller and CODESYS programming examples, and provides an overview of the C4374 product features, function descriptions, configuration methods, wiring diagrams, and installation details. An introduction to the Modbus communication protocol is also attached.

Validity Statement

In line with our continuous improvement policy, we will continually revise the content to make it clearer and more accurate.

Odot Automation System Co., Ltd. reserves the right of final interpretation of this manual.

Product Information

DANGER

There is a risk of electric shock, explosion, or arc flash

- Disconnect all devices from power, including connected devices, before removing any covers, or installing or removing any accessories, hardware, cables, or wires, except in specific circumstances specified in the appropriate hardware guidelines for this device.
- As instructed, it is important to use a voltage sensing device with an appropriate rating to detect a power outage at the appropriate place and time.
- Replace and tighten all covers, accessories, hardware, cables, and wires, and confirm that the ground connection is correct before powering on the device.
- When operating this equipment and related products, the specified voltage must be used.

Failure to follow these instructions will result in death, personal injury, or serious injury.

DANGER

There may be a risk of explosion

- Do not connect or disconnect the device unless it has been unplugged or the location is determined to be non-hazardous.
- The USB port (if equipped) should only be used if it is determined that the work area is a non-

hazardous area.

Failure to follow the instructions may result in the loss of the protection provided by the device, which may result in serious consequences such as death, personal injury, or damage to the device.



Warning

Loss of control

·The designer of any control scheme must take into account the possibility of a failure of the control path and provide a way for certain critical control functions to return to a safe state in the event of a path failure and after a path failure. These critical control functions include emergency stops, overrun stops, power failure restarts, and similar safety measures.

·For critical control functions, separate or redundant control paths must be provided.

·The system control path may include a communication link. Implicit unforeseen transmission delays or link failures must be taken into account.

·Follow all accident prevention regulations and local safety guidelines.

·In order to guarantee correct operation, the equipment must be thoroughly tested separately for each execution before it is put into service.

Failure to follow the instructions may result in the loss of the protection provided by the device, which may result in serious consequences such as death, personal injury, or damage to the device.

WARNING

UNEXPECTED DEVICE OPERATION

·USE ONLY SOFTWARE APPROVED BY SICHUAN ZERO AUTOMATION THAT CAN BE USED WITH THIS EQUIPMENT.

·UPDATE THE APPLICATION EACH TIME YOU MAKE CHANGES TO THE PHYSICAL HARDWARE CONFIGURATION.

FAILURE TO FOLLOW THE INSTRUCTIONS MAY RESULT IN THE LOSS OF THE PROTECTION PROVIDED BY THE DEVICE, WHICH MAY RESULT IN SERIOUS CONSEQUENCES SUCH AS DEATH, PERSONAL INJURY, OR DAMAGE TO THE DEVICE.

WARNING

UNEXPECTED DEVICE OPERATION

THE RISK ASSESSMENT SHOULD INCLUDE THE POSSIBILITY OF COMMUNICATION FAILURES BETWEEN THE LOGIC CONTROLLER AND ANY I/O EXPANSION MODULES. IF THE IO MODULE OUTPUT SIGNAL "KEEP CURRENT" DOES NOT MATCH YOUR APPLICATION REQUIREMENTS WHEN THE I/O EXPANSION BUS IS FAULTY, OTHER SCENARIOS SHOULD BE USED TO ENSURE THAT THE APPLICATION CAN COPE WITH THE BUS ERROR EVENT.

THE STATUS OF THE I/O EXPANSION BUS IS MONITORED USING A DEDICATED SYSTEM WORD AND APPROPRIATE MEASURES ARE TAKEN AS DETERMINED BY THE RISK ASSESSMENT.

FAILURE TO FOLLOW THE INSTRUCTIONS MAY RESULT IN THE LOSS OF THE PROTECTION PROVIDED BY THE DEVICE, WHICH MAY RESULT IN SERIOUS CONSEQUENCES SUCH AS DEATH, PERSONAL INJURY, OR DAMAGE TO THE DEVICE.

Version information

The following changes have been made to the document:

Date	Version	Modifications	Author
2024-12-02	V1.0	Release version	YPP

Ownership Information

This document may not be republished, in whole or in part, in paper or electronic form, without the consent of the copyright owner.

Disclaimer

This document is intended only to assist readers in the use of the product, and the Company shall not be liable for any loss or error arising from the use of the information in this document. The products and texts described in this document are constantly being developed and improved. The Company reserves the right to modify this document without notifying the User.

Software downloads

If you need to download the device description file or IO Config software, please log in to the official website of Odot Automation: www.odot.cn, select the corresponding product page on the support and service page, and click Download. To download Codesys software, please log in to the www.codesys.cn page to download it.

Disclaimer of Warranties

Product Usage

Note

- When installing, operating, and maintaining the equipment, do not exceed any of the ratings specified in the electrical characteristics;
- When installing, operating, and maintaining the equipment, do not exceed any of the ratings specified in the environmental characteristics. Do not use the product

in the following places: places with dust, oil fumes, conductive dust, corrosive gases, and flammable gases; Do not expose to high temperatures, condensation, wind and rain; Vibration and shock will also cause damage to the product; Failure to follow the instructions may render the protection provided by the device null and may result in minor bodily injury or damage to the device.

Disclaimer of Warranties

The Company shall not be liable for any damage or malfunction of the equipment caused by:

1. Transportation damage: equipment damage caused by improper transportation or packaging;
2. Natural factors: damage caused by lightning strikes, voltage fluctuations, water ingress or natural disasters (such as fires, floods, etc.);
3. Improper use: damage caused by overload, non-standard operation, unauthorized modification or use of unqualified accessories;
4. Unauthorized maintenance: equipment failure caused by unauthorized maintenance or alteration;
5. Other non-product reasons: damage caused by other reasons that have nothing to do with the equipment itself.

Repair services

1. For the damage caused by the above reasons, the company will charge the repair fee according to the actual situation.
2. Outside the warranty period, the company provides paid maintenance services, and the cost is charged according to the maintenance situation.

Assumption of Risk

The company shall not be liable for casualties, property damage or other related losses caused by the use of the equipment. All risks are borne by the user.

Catelog

1 Product Overview	16
1.1 Brief introduction.....	16
1.2 Selection Table	18
1.3 LED Indicator	21
1.4 Earthing.....	21
1.5 Wiring	24
1.6 Installation.....	25
1.7 Power supply.....	34
1.8 Ventilation requirements	35
1.9 Scrapped.....	35
1.10 Equipment maintenance and repair.....	36
2 Module parameters.....	37
2.1 Technical parameters.....	37
2.2 Hardware interfaces	39
2.3 Wiring	43
2.4 Dimension	46
3 IO Config Software.....	47
3.1 IO Config Software Installation.....	47
3.2 Software interface	48
3.3 Software function.....	56
4 Programming software (Codesys)	65
4.1 Programming software installation	65
4.2 Use of Codesys software.....	70
4.3 Download & Monitor.....	76
5 Example demonstration	78
5.1 Control demand.....	78
5.2 Preparation	78

5.3 Project Establishment.....	79
5.4 Program download and monitoring	87
6 Example of communication	88
6.1 Modbus TCP Client.....	88
6.2 Modbus TCP Server	99
6.3 Modbus RTU Master.....	110
6.4 Modbus RTU Slave.....	121
6.5 EtherCAT Master	131
6.6 CANOpen Master	140
7 Appendix	155
7.1 Modbus-RTU protocol introduction	155
7.2 Brief introduction of serial network topology	162

1 Product Overview

1.1 Brief introduction

The C4374 programming environment is Codesys, which follows the IEC61131-3 international standard programmable logic controller, supports ladder diagram (LD), instruction list (IL), structured text (ST), function block diagram (CFC/FBD), sequential function chart (SFC) five programming languages, user program storage supports 4 Mbytes, data memory supports 4 Mbytes, and supports up to 5 task states. The module supports the mounting of 32 IO modules, and the CPU and IO modules are designed separately, which can be freely combined according to the needs of the site, and can achieve lower cost requirements in the case of a large number of points. The module has 3*RJ45/1*RS485/1*CAN interfaces, supports Modbus RTU, Modbus TCP, EtherCAT, CANOpen protocol access, easy configuration, fast debugging. -30°C~70°C wide temperature of the whole machine, it can cope with various industrial sites, EMC performance to meet IEC61131-2, IEC61000-4 standards. The expansion module is mainly divided into 6 categories, digital input module, digital output module, analog input module, analog output module, special module and hybrid IO module.

Module features

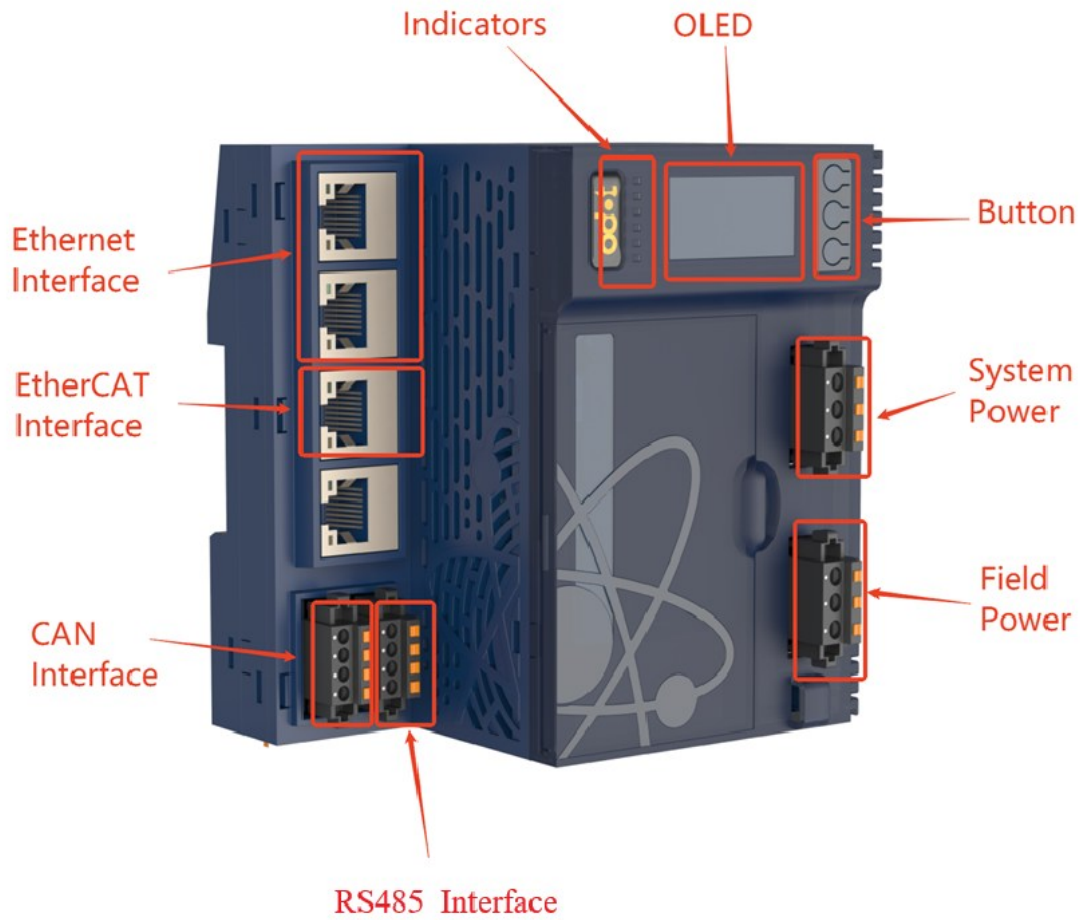

1.2 Selection Table

Serial number	Model	Description of the function	State
1	CT-1218	8-channel digital input PNP/24V active	Published
2	CT-121F	16 channels of digital input PNP/24V active	Published
3	CT-1228	8-channel digital input NPN/0V active	Published
4	CT-122F	16-channel digital input NPN/0V active	Published
5	CT-124H	32 channels of digital inputs, PNP/24V active, NPN/0V active	Published
6	CT-124D	32 channels of digital inputs, PNP/24V active, NPN/0V active	Published
7	CT-125F	16 channels of digital input PNP/24V active	Published
8	CT-126F	16-channel digital input NPN/0V active	Published
9	CT-1314	4-channel digital input 220VAC	Published
10	CT-2224	4-channel digital output 2A/PNP/24V active	Published
11	CT-2218	8-channel digital output: 0.5A/NPN/0V active	Published
12	CT-2228	8-channel digital output: 0.5A/PNP/24V active	Published
13	CT-222F	16-channel digital output 0.5A/PNP/24V active	Published
14	CT-222F-NP	16-channel digital output 0.5A/PNP/24V active	Published
15	CT-222H	32-channel digital output 0.5A/PNP/24V active	Published
16	CT-222D	32-channel digital output 0.5A/PNP/24V active	Published
17	CT-221F	16-channel digital output: 0.5A/NPN/0V active	Published
18	CT-221H	32-channel digital output 0.5A/NPN/0V active	Published
19	CT-221D	32-channel digital output 0.5A/NPN/0V active	Published
20	CT-2244	4-channel digital output: 0.5A/PNP/24V active NPN/0V active	Unpublished
21	CT-225F	16-channel digital output 0.25A/NPN/0V active	Published
22	CT-226F	16-channel digital output 0.5A/PNP/24V active	Unpublished
23	CT-2738	8-channel relay output 1A/30VDC/30W	Published
24	CT-2754	4-channel relay output 3A/30VDC/90W	Published
25	CT-2794	4-channel relay output 2A/250VAC/500VA	Published
26	CT-3134	4 channel voltage inputs 0~5VDC/0~10VDC/±5VDC/±10VDC, 15 bits/16 bits	Published
27	CT-3168	8-channel voltage inputs 0~5VDC/0~10VDC/±5VDC/±10VDC, 15 bits/16 bits	Published
28	CT-3234	4-channel analog inputs 0&4-20mA, 15-bit single-ended	Published
29	CT-3238	8 channels of analogue inputs 0&4-20mA, 15-bit single-ended	Published
30	CT-3268	8 channels of analogue inputs 0~20mA /- 20~0mA /±20mA, 15-bit single-ended bipolar	Published
31	CT-3274	4-channel analog inputs 0~20mA /4~20mA	Published

		/±20mA ,16-bit differential inputs	
32	CT-3713	3-channel RTD input RTD-PT100	Published
33	CT-3723	3-channel RTD input RTD-PT1000	Published
34	CT-3716	6-channel RTD input RTD-PT100	Published
35	CT-3726	6-channel RTD input RTD-PT1000	Published
36	CT-3734	4-channel RTD input RTD-PT100, with isolation between channels	Published
37	CT-3744	4-channel RTD input RTD-PT1000, with isolation between channels	Published
38	CT-3844	4-channel thermocouple input (adjustable filtering) TC-J / K / E / T / S / R / B / N / C type	Published
39	CT-3848	8-channel thermocouple input (adjustable filtering). TC-J / K / E / T / S / R / B / N / C type	Published
40	CT-4154	4 channels of voltage output 0~5VDC/0~10VDC/±5VDC/±10VDC,16-bit	Published
41	CT-4158	8 channel voltage output 0~5VDC/0~10VDC/±5VDC/±10VDC,16-bit	Published
42	CT-4234	4 channels of analogue output 0&4-20mA/16-bit single-ended	Published
43	CT-4238	8 channels of analogue output 0&4-20mA/16-bit single-ended	Published
44	CT-5000	Virtual Modules	Published
45	CT-5102	2-channel encoder input 5VDC	Published
46	CT-5112	2-channel encoder input 24VDC	Published
47	CT-5122	2-channel encoder SSI input	Published
48	CT-5142	2-channel encoder differential input	Published
49	CT-5212	8 channels digital input/2 channels digital output/2 channels pulse output	Published
50	CT-5224	4-channel digital input/4-channel digital output/4-channel PWM output	Published
51	CT-5321	1-channel serial module Modbus master/Modbus slave/free protocol	Published
52	CT-5331	1-channel CANopen master module	Published
53	CT-5341	1-channel Profibus DP master module	Published
54	CT-5711	Bus Extension Master Module	Published
55	CT-5721	Bus Extension Slave Module	Published
56	CT-5801	Terminal module (stateless, no configuration required)	Published
57	CT-5802	Terminal module (stateless, no configuration required)	Unpublished
58	CT-623F	8-channel digital inputs: PNP/24V active, NPN/0V active	Published
		8-channel digital output: 0.5A/PNP/24V active	
59	CT-7100	Field Power Expansion Module 24V/8A (stateless, no configuration required)	Published
60	CT-7220	Power Expansion Module SV: 5V/2A FV: 24V/8A (stateless, no configuration required)	Published
61	CT-7221	Power Expansion Module SV: 5V/2A FV:	Published

24V/8A			
62	CT-730F	18-channel field power distribution module 18*0VDC	Published
63	CT-731F	18-channel field power distribution module 18*24VDC	Published
64	CT-732F	18-channel field power distribution module 18*PE	Published
65	CT-7339	18-channel field power distribution module 9*24VDC/9*0VDC	Published
66	CT-7346	18-channel field power distribution module 6*24VDC/6*0VDC/6*PE	Published

1.3 LED Indicator

The user can easily check the power status of the PLC and I/O modules, the operating status of the I/O modules, and the number of I/O channels through the LED status indicator. Detailed indicator status refers to individual adapters or IO modules.



WARNING

LOSS OF CONTROL

- REFER TO THE INSTRUCTIONS IN THE CORRESPONDING SECTION FOR THE INDICATOR STATUS OF THE PLC.
- REFER TO THE INSTRUCTIONS IN THE CORRESPONDING SECTION FOR THE INDICATOR STATUS OF THE I/O MODULE.
- DIFFERENT INDICATOR STATUSES INDICATE THAT THE MODULE IS IN DIFFERENT WORKING STATES.
- THE INDICATOR STATUS IS INCORRECT, AND THE MODULE IS WORKING ABNORMALLY.

FAILURE TO FOLLOW THE INSTRUCTIONS MAY RESULT IN THE LOSS OF THE PROTECTION PROVIDED BY THE DEVICE, WHICH MAY RESULT IN SERIOUS CONSEQUENCES SUCH AS DEATH, PERSONAL INJURY, OR DAMAGE TO THE DEVICE.

1.4 Earthing

There is a metal shrapnel on the back of the module for effective grounding with the guide rail, and the metal shrapnel is connected to the grounding PE of the adapter module.

Functional grounding on the rails

The system's DIN rails are common, functional ground planes and must always be mounted on a conductive backplate.

WARNING

UNEXPECTED DEVICE OPERATION

- **CONNECT THE DIN RAIL TO THE FUNCTIONAL GROUND OF THE MOUNTING DEVICE.**
- FAILURE TO FOLLOW THE INSTRUCTIONS MAY RESULT IN THE LOSS OF THE PROTECTION PROVIDED BY THE DEVICE, WHICH MAY RESULT IN SERIOUS CONSEQUENCES SUCH AS DEATH, PERSONAL INJURY, OR DAMAGE TO THE DEVICE.**

System grounding

Due to the effects of electromagnetic interference, cables carrying fast I/O, analog I/O, and fieldbus communication signals must be shielded.



WARNING

UNEXPECTED DEVICE OPERATION

- **USE SHIELDED CABLES FOR ALL FAST I/O, ANALOG I/O, AND COMMUNICATION SIGNALS.**
 - **SINGLE-POINT GROUNDING WITH SHIELDED CABLES FOR ALL FAST I/O, ANALOG I/O, AND COMMUNICATION SIGNALS [1].**
 - **ROUTE POWER CABLES SEPARATELY FROM COMMUNICATION CABLES AND I/O CABLES.**
- FAILURE TO FOLLOW THE INSTRUCTIONS MAY RESULT IN THE LOSS OF THE PROTECTION PROVIDED BY THE DEVICE, WHICH MAY RESULT IN SERIOUS CONSEQUENCES SUCH AS DEATH, PERSONAL INJURY, OR DAMAGE TO THE DEVICE.**

[1] Multi-point grounding is allowed if connected to an equipotential ground plane to avoid damage to the cable shield in the event of a short-circuit current in the power supply system (which is unavoidable in some cases). When using shielded cables, the following wiring rules need to be followed:

For protective grounding to condensation (PE), metal pipes or wires can be used as partial shield lengths, provided that the entire ground connection is uninterrupted, for functional grounding, shielding is used to reduce electromagnetic interference, and the shielding of the entire cable must be continuous and uninterrupted, if it is for both functional and protective purposes (as is the case with communication cables). At the same time, cables that transmit different types of signals or power sources should be separated

Protective grounding on the backplate (PE)

Protective Grounding (PE) is connected to a conductive backplate by a heavy-duty conductor, typically a copper braided cable with the maximum allowable cable cross-section. There is a metal shrapnel on the back of the module for effective grounding with the guide rail, and the metal shrapnel is connected to the PE inside the terminal block of the adapter module. The conductor needs to be made of copper wire with a core greater than 0.2mm^2 and less than 1mm^2 , and an impedance of less than 10 ohms.

Shielded cable connection

Cables carrying fast I/O, analog I/O, and fieldbus communication signals must be shielded. The shielded cable must be firmly grounded. Fast I/O and analog I/O shields can be connected to the module's functional or protective ground (PE). The fieldbus communication cable shield must be connected to the protective ground (PE) using a connection clamp fixed to the mounted conductive backplate.

1.5 Wiring

Use a push-in connection to connect single wires or crimp terminal (ferrule) wires without any additional tools. Users save time on cabling and guarantee a secure connection regardless of wiring experience.

The module has a wiring harness fixed end, which is used to fix the cable when the IO module is connected to a multi-strand cable.

WARNING

UNEXPECTED DEVICE OPERATION

- **USE SHIELDED CABLES FOR ALL FAST I/O, ANALOG I/O, AND COMMUNICATION SIGNALS.**
- **SINGLE-POINT GROUNDING WITH SHIELDED CABLES FOR ALL FAST I/O, ANALOG I/O, AND COMMUNICATION SIGNALS.**
- **ROUTE POWER CABLES SEPARATELY FROM COMMUNICATION CABLES AND I/O CABLES.**

FAILURE TO FOLLOW THE INSTRUCTIONS MAY RESULT IN THE LOSS OF THE PROTECTION PROVIDED BY THE DEVICE, WHICH MAY RESULT IN SERIOUS CONSEQUENCES SUCH AS DEATH, PERSONAL INJURY, OR DAMAGE TO THE DEVICE.

Multi-point grounding is allowed if connected to an equipotential ground plane to avoid damage to the cable shield in the event of a short-circuit current in the power supply system (which is unavoidable in some cases).

Note: Surface temperatures may exceed 60°C (140°F).

To comply with the IEC-61010 standard, the primary wiring (the wires connected to the main power supply) should be arranged separately and separated from the secondary wiring (ultra-low voltage wiring from the intermediate power supply). If it is not possible to separate the wiring, double insulation, such as conduit or cable gain, must be done.

Note: Copper wires are required.

Dangerous

FIRE HAZARD

- **USE ONLY THE CORRECT WIRE RULES FOR THE MAXIMUM CURRENT CAPACITY OF THE I/O CHANNELS AND POWER SUPPLY.**

• **FOR RELAY OUTPUT (2A) WIRING, USE A CONDUCTOR WITH A CROSS-SECTIONAL AREA OF AT LEAST 0.5 SQUARE MILLIMETERS (AWG20) AND A TEMPERATURE RATING OF AT LEAST 80°C (176°F).**

FAILURE TO FOLLOW THE INSTRUCTIONS MAY RESULT IN THE LOSS OF THE PROTECTION PROVIDED BY THE DEVICE, WHICH MAY RESULT IN SERIOUS CONSEQUENCES SUCH AS DEATH, PERSONAL INJURY, OR DAMAGE TO THE DEVICE.

1.6 Installation

Equipment installation requirements

The use and application of the information contained in this chapter requires expertise in the design and programming of automated control systems. Only the user, machine builder or integrator is clearly aware of the various situations and factors that may arise during installation and set-up, operation and maintenance, and can therefore be sure that automation and associated equipment, associated safety devices and interlocks can be used effectively and correctly. All applicable local, regional, or national standards and/or regulations must also be considered when selecting automation and control equipment and any other related equipment or software for a particular application.

In particular, care is taken to comply with any safety information, different electrical requirements and normative standards that apply to the machine or equipment in use. If the device is used in a manner not specified by the manufacturer, the protection provided by the device may be voided.

Environmental requirements

All expansion module components must be electrically isolated between the internal circuitry and the input/output channels, and the modules must be installed in a control cabinet or control room and are intended for use in industrial environments with pollution class 2 and below 2000 meters above sea level.



WARNING

UNEXPECTED DEVICE OPERATION

- **DO NOT EXCEED ANY OF THE RATINGS SPECIFIED IN THE ENVIRONMENTAL AND ELECTRICAL CHARACTERISTICS TABLE.**

FAILURE TO FOLLOW THE INSTRUCTIONS MAY RESULT IN THE LOSS OF THE PROTECTION PROVIDED BY THE DEVICE, WHICH MAY RESULT IN SERIOUS CONSEQUENCES SUCH AS DEATH, PERSONAL INJURY, OR DAMAGE TO THE DEVICE.



UNEXPECTED DEVICE OPERATION

- **THE MODULE IS NOT SUITABLE FOR USE IN HARSH ENVIRONMENTS, SUCH AS THOSE WITH CORROSIVE GASES OR SALT SPRAY.**
- **INSTALL AND OPERATE THIS EQUIPMENT IN ACCORDANCE WITH THE CONDITIONS COMPLAINED OF IN THE "ENVIRONMENTAL CHARACTERISTICS".**

FAILURE TO FOLLOW THE INSTRUCTIONS MAY RESULT IN THE LOSS OF THE PROTECTION PROVIDED BY THE DEVICE, WHICH MAY RESULT IN SERIOUS CONSEQUENCES SUCH AS DEATH, PERSONAL INJURY, OR DAMAGE TO THE DEVICE.

Installation precautions



UNEXPECTED DEVICE OPERATION

- **IN SITUATIONS WHERE THERE MAY BE A RISK OF INJURY TO PERSONNEL AND/OR DAMAGE TO EQUIPMENT, USE APPROPRIATE SAFETY INTERLOCKS.**
- **INSTALL AND OPERATE THIS EQUIPMENT IN A CHASSIS THAT MEETS THE ENVIRONMENTAL RATING IN WHICH THIS EQUIPMENT IS OPERATING AND IS LOCKED BY A KEY LOCKING DEVICE.**
- **USE SENSOR AND ACTUATOR POWER SUPPLIES ONLY TO POWER SENSORS OR ACTUATORS CONNECTED TO THE MODULE.**
- **WIRING AND INSTALLING FUSES MUST BE COMPLIED WITH LOCAL AND NATIONAL REGULATIONS FOR CURRENT AND VOLTAGE RATINGS FOR SPECIFIC EQUIPMENT.**
- **DO NOT USE THIS EQUIPMENT IN A MACHINE ENVIRONMENT WHERE SAFETY REQUIREMENTS ARE VERY HIGH, UNLESS THE EQUIPMENT IS DESIGNATED AS A FUNCTIONAL SAFETY DEVICE AND FOLLOWS APPLICABLE REGULATIONS AND STANDARDS.**
- **DO NOT DISASSEMBLE, REPAIR, OR MODIFY THIS APPLIANCE.**
- **DO NOT CONNECT ANY LINES TO UNUSED CONNECTION POINTS THAT HAVE BEEN RESERVED, OR CONNECTION POINTS THAT INDICATE NO Connection (NC).**
- **THE SAFETY OF ANY SYSTEM INCORPORATED WITH THIS DEVICE IS THE RESPONSIBILITY**

OF THE ASSEMBLER OF THE SYSTEM.

FAILURE TO FOLLOW THE INSTRUCTIONS MAY RESULT IN THE LOSS OF THE PROTECTION PROVIDED BY THE DEVICE, WHICH MAY RESULT IN SERIOUS CONSEQUENCES SUCH AS DEATH, PERSONAL INJURY, OR DAMAGE TO THE DEVICE.

Install correctly

The DIN rail lock can be mounted safely and reliably on a 35 mm DIN rail. On the upper side of all modules there is a manual closing clasp for locking the buckle, and on the left side of the adapter there is a manual clip for locking the rail.

The module can be installed vertically or horizontally, and the schematic diagram of vertical installation and horizontal installation is as follows:

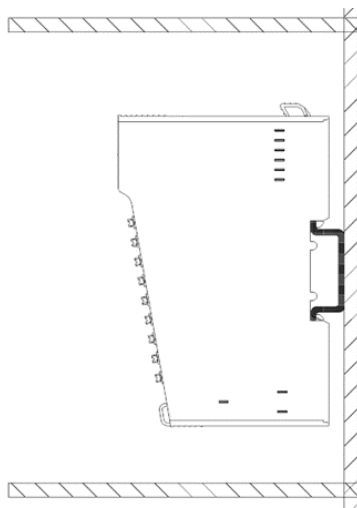

① Vertical mounting side view

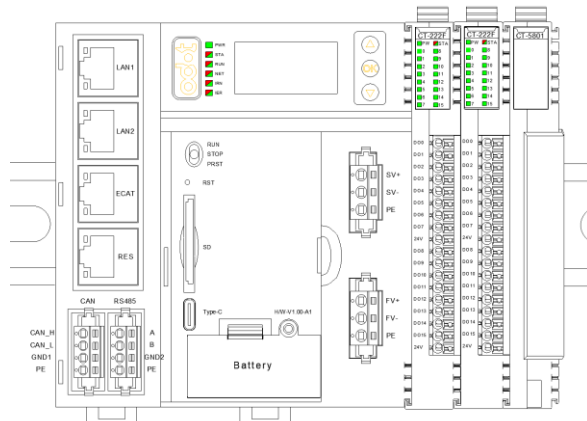

② Vertical mounting (rail horizontal)

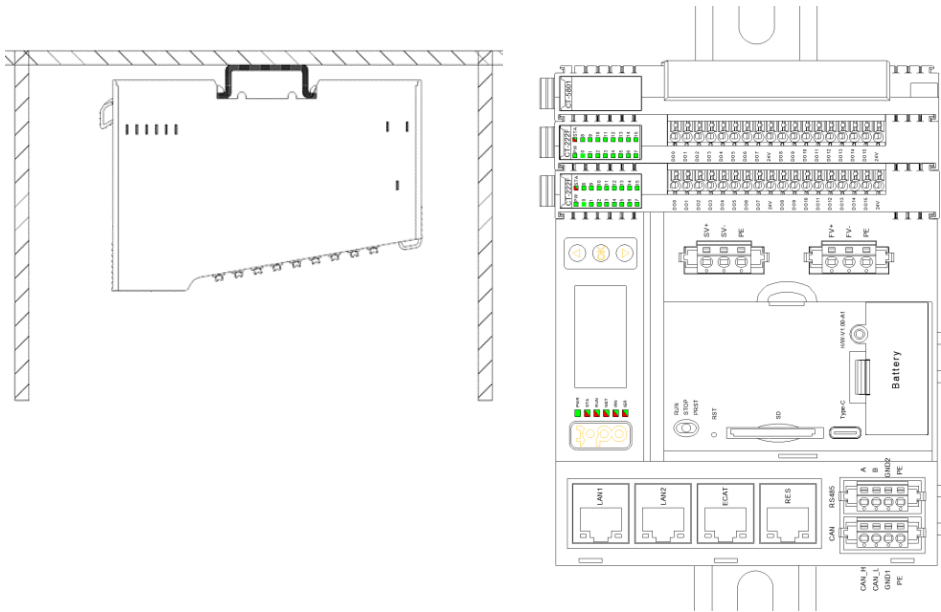

③ Top view of horizontal installation

④ Horizontal mounting (rail vertical)

! WARNING

LOSS OF CONTROL

- **THE BUCKLE OF THE MODULE MUST BE STUCK IN PLACE, OTHERWISE IT MAY CAUSE THE I/O MODULE TO BE DISCONNECTED.**
 - **THE CLIPS OF THE MODULE MUST BE SNAPPED IN PLACE, OTHERWISE THE MODULE MAY FALL.**
 - **THERE SHOULD BE NO GAPS BETWEEN MODULES WHEN THE MODULES ARE INSTALLED. FAILURE TO DO SO MAY RESULT IN THE I/O CHANNELS NOT WORKING PROPERLY.**
- Failure to follow the instructions may result in the loss of the protection provided by the device, which may result in serious consequences such as death, personal injury, or damage to the device.**

NOTE

THE DEVICE IS INOPERABLE

- **THE I/O MODULE IN THE MIDDLE IS NOT FIXED. ACCORDING TO THE CUSTOMER'S NEEDS, THE LAYOUT POSITION IS NOT ALLOWED TO MOVE THE I/O MODULE AFTER THE INSTALLATION LOCATION IS CONFIRMED IN THE ACTUAL PROJECT.**
 - **TERMINAL MODULES NEED TO BE ADDED TO EACH SITE.**
- FAILURE TO FOLLOW THE ABOVE INSTRUCTIONS MAY RESULT IN DAMAGE TO THE DEVICE.**

Power module use

The power module needs to be added according to the actual number of I/O modules, and the placement position of the power module is between the I/O modules, and the specific slots are not fixed, so the drawing designer needs to consider the installation position of the power module in advance.

 **WARNING**

UNEXPECTED DEVICE OPERATION

• **IF THE TOTAL CURRENT OF THE I/O MODULE INSTALLED BEHIND THE DEVICE EXCEEDS THE CURRENT PROVIDED, BUT THE POWER MODULE IS NOT ADDED, THE I/O MODULE CHANNEL WILL WORK ABNORMALLY.**

FAILURE TO FOLLOW THE INSTRUCTIONS MAY RESULT IN THE LOSS OF THE PROTECTION PROVIDED BY THE DEVICE, WHICH MAY RESULT IN SERIOUS CONSEQUENCES SUCH AS DEATH, PERSONAL INJURY, OR DAMAGE TO THE DEVICE.

Disassembly

When disassembling the module, need to manually open the rail lock on the upper side of the module, and for the adapter module, also need to open the rail lock counterclockwise.

WARNING

UNEXPECTED DEVICE OPERATION

- **THE MODULE DOES NOT SUPPORT HOT-SWAP FUNCTION, AND WHEN REMOVING OR REPLACING THE MODULE, YOU NEED TO POWER OFF FIRST AND THEN REMOVE OR REPLACE THE MODULE.**
- **WHEN REPLACING THE I/O MODULE FOR LATER MAINTENANCE, PAY ATTENTION TO THE MODEL AND SLOT NUMBER TO BE REPLACED, AND IT IS NOT ALLOWED TO REPLACE THE WRONG MODULE MODEL OR MOVE THE I/O MODULE SEQUENCE AT WILL, OTHERWISE THERE WILL BE A RISK OF BURNING OUT THE MODULE OR DAMAGING THE FIELD EQUIPMENT.**

FAILURE TO FOLLOW THE INSTRUCTIONS MAY RESULT IN THE LOSS OF THE PROTECTION PROVIDED BY THE DEVICE, WHICH MAY RESULT IN SERIOUS CONSEQUENCES SUCH AS DEATH, PERSONAL INJURY, OR DAMAGE TO THE DEVICE.

Installation clearance

When installing or removing modules, minimal clearance must be maintained.

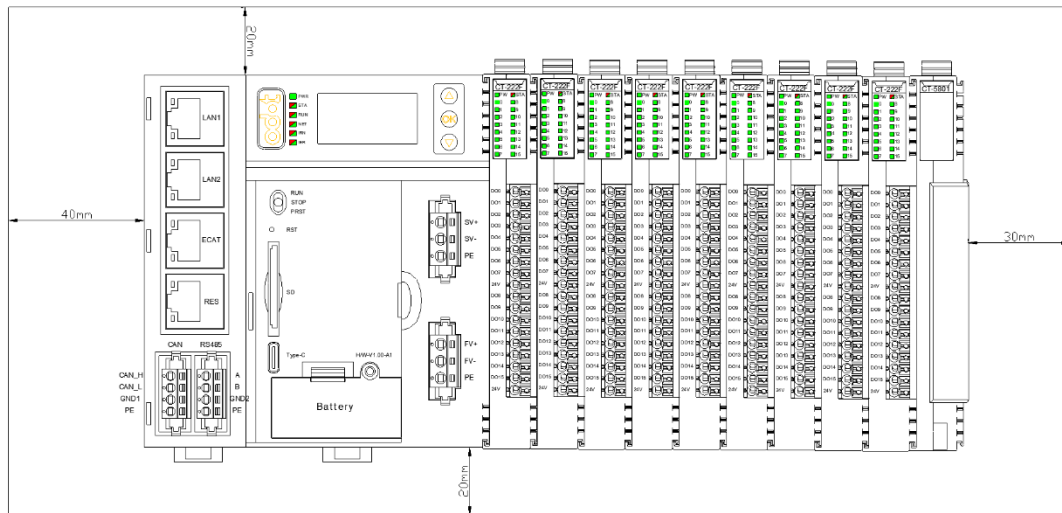

Warning

UNEXPECTED DEVICE OPERATION

- **INSTALL THE DEVICE THAT DISSIPATES THE MOST HEAT ON TOP OF THE CABINET TO ENSURE PROPER VENTILATION.**
- **DO NOT PLACE THE DEVICE NEXT TO OR ON TOP OF A DEVICE THAT MAY CAUSE OVERHEATING.**
- **INSTALL THE DEVICE IN A PLACE THAT MAINTAINS THE MINIMUM DISTANCE FROM ALL NEARBY STRUCTURES AND EQUIPMENT AS DESCRIBED IN THIS DOCUMENT.**
- **INSTALL ALL EQUIPMENT IN ACCORDANCE WITH THE SPECIFICATIONS IN THE RELEVANT DOCUMENTATION.**

FAILURE TO FOLLOW THE INSTRUCTIONS MAY RESULT IN THE LOSS OF THE PROTECTION PROVIDED BY THE DEVICE, WHICH MAY RESULT IN SERIOUS CONSEQUENCES SUCH AS DEATH, PERSONAL INJURY, OR DAMAGE TO THE DEVICE.

Incorrect installation

- A. The left buckle of the device is not locked on the guide rail.
- B. After the installation is completed, the buckle on the upper side of the module is not pressed to the locking rail, or the pressed position is not pressed in place.
- C. After the installation is completed, the underside of the side of the module is not installed in place, and the module is not installed vertically, and it is inclined to the backplate.
- D. There is a gap between the modules.

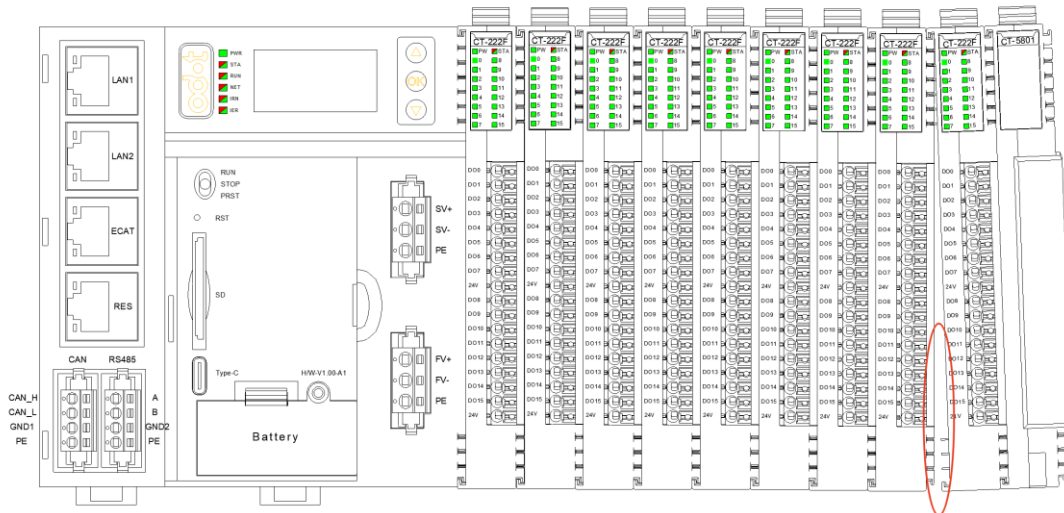
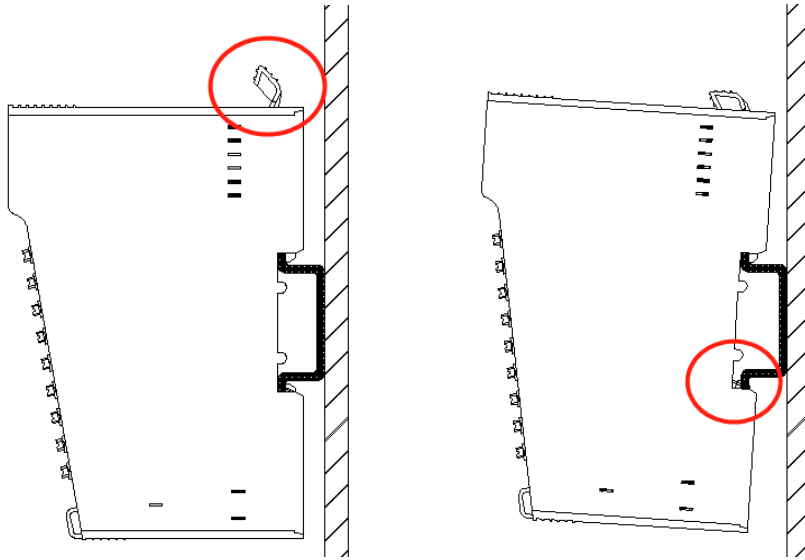

Installation dimensions

The installation size of C4173 equipment: 115*102*82mm

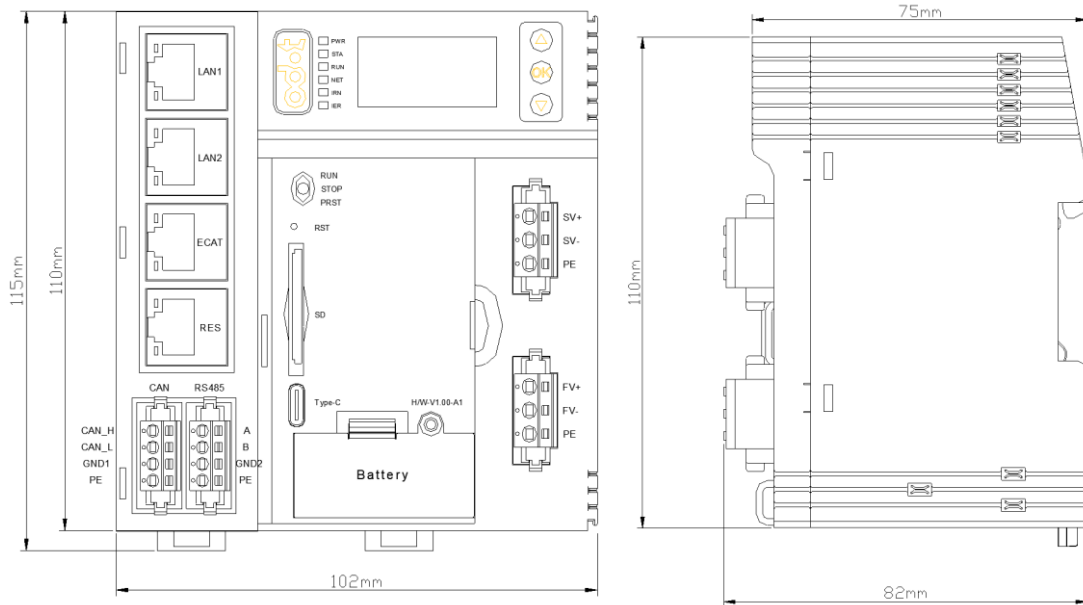

1.7 Power supply

Dangerous

FIRE HAZARD

- **FOR THE MAXIMUM CURRENT CAPACITY OF THE POWER SUPPLY, ONLY THE CORRECT WIRE SIZE IS USED.**

FAILURE TO FOLLOW THE INSTRUCTIONS MAY RESULT IN THE LOSS OF THE PROTECTION PROVIDED BY THE DEVICE, WHICH MAY RESULT IN SERIOUS CONSEQUENCES SUCH AS DEATH, PERSONAL INJURY, OR DAMAGE TO THE DEVICE.

WARNING

UNEXPECTED DEVICE OPERATION

- **DO NOT EXCEED ANY OF THE RATINGS SPECIFIED IN THE ENVIRONMENTAL AND ELECTRICAL CHARACTERISTICS TABLE.**

FAILURE TO FOLLOW THE INSTRUCTIONS MAY RESULT IN THE LOSS OF THE PROTECTION PROVIDED BY THE DEVICE, WHICH MAY RESULT IN SERIOUS CONSEQUENCES SUCH AS DEATH, PERSONAL INJURY, OR DAMAGE TO THE DEVICE.

The device and associated expansion IO module require a power supply rated at 24 Vdc, which must be rated as either a safe ultra-low voltage (SELV) or a protective ultra-low voltage (PELV). These power supplies are isolated between the electrical input and output circuitry of the power supply.

WARNING

OVERHEATING AND FIRE HAZARDS

- **NEVER CONNECT THE DEVICE DIRECTLY TO THE LINE VOLTAGE.**
- **PLEASE USE ONLY AN INSULATED SELV OR PELV POWER SUPPLY TO POWER THE DEVICE.**

FAILURE TO FOLLOW THE INSTRUCTIONS MAY RESULT IN THE LOSS OF THE PROTECTION PROVIDED BY THE DEVICE, WHICH MAY RESULT IN SERIOUS CONSEQUENCES SUCH AS DEATH, PERSONAL INJURY, OR DAMAGE TO THE DEVICE.

1.8 Ventilation requirements

NOTE

- **IO MODULE, PLEASE INSTALL IN THE CONTROL CABINET WITH DOOR LOCK (CONTROL CABINET HOUSING PROTECTION >IP20);**
 - **THE INSTALLATION SHOULD NOT BE PLACED UNDER THE COMPONENTS WITH LARGE HEAT GENERATION, AND THE SURROUNDING VENTILATION AND HEAT DISSIPATION SPACE SHOULD BE LARGE ENOUGH, AND THERE SHOULD BE A SEPARATION OF MORE THAN 30MM BETWEEN THE BASIC UNIT AND THE EXPANSION UNIT;**
 - **THERE SHOULD BE VENTILATED SHUTTERS ON THE UPPER AND LOWER PARTS OF THE SWITCH CABINET TO PREVENT DIRECT SUNLIGHT;**
 - **AVOID METAL CHIPS AND WIRES FALLING INTO THE VENTILATION HOLES OF THE CONTROLLER DURING INSTALLATION, WHICH MAY CAUSE FIRE, MALFUNCTION AND MISOPERATION.**
- FAILURE TO FOLLOW THE ABOVE INSTRUCTIONS MAY RESULT IN DAMAGE TO THE DEVICE.**

1.9 Scrapped

Scrapping conditions:

1. The service life has exceeded the specified service life, the main structure is outdated, the components are aging, the performance indicators are reduced, and the basic requirements for use are not met;
2. The damage is serious and cannot be repaired or the repair cost is close to or exceeds the price of the new electronic equipment purchased;
3. Seriously polluting the environment, endangering personal safety and health, making it difficult to transform the technology or the cost of transformation is uneconomical;
4. Backward technical performance, high energy consumption, low efficiency, uneconomical maintenance and use.
5. Equipment that cannot be used for other reasons, and should not be transferred to other enterprises, and has no retained value.



WARNING: AS THIS PRODUCT CANNOT BE DISPOSED OF WITH OTHER HOUSEHOLD WASTE, WHEN THE END USER INTENDS TO DISPOSE OF THIS PRODUCT, THE PRODUCT MUST BE TAKEN TO AN APPROPRIATE FACILITY FOR RECOVERY AND RECYCLING.

- **DO NOT DISPOSE OF IT DIRECTLY IN THE TRASH.**
- **COMPLY WITH RELEVANT LAWS AND REGULATIONS, AND CHOOSE A LEGAL ORGANIZATION FOR DISPOSAL DURING THE DESTRUCTION PROCESS.**

1.10 Equipment maintenance and repair

NOTE

- **DO NOT REPLACE DETACHABLE POWER CORDS WITH WIRES WITH INAPPROPRIATE RATINGS.**
 - **ANY PARTS AND COMPONENTS THAT CAN ONLY BE INSPECTED OR SUPPLIED BY THE MANUFACTURER OR ITS AGENTS.**
 - **ONLY FOR THE MANUFACTURE OF ELECTRICAL EQUIPMENT AND FOR PERSONNEL WITH RELEVANT SKILLS AND KNOWLEDGE.**
 - **CONFIRM THE SAFETY STATUS OF THE EQUIPMENT AFTER MAINTENANCE**
- FAILURE TO FOLLOW THE ABOVE INSTRUCTIONS MAY RESULT IN DAMAGE TO THE DEVICE.**

2 Module parameters

2.1 Technical parameters

General parameters	
System Power	Power supply: 19.2-28.8VDC (Nominal: 24VDC) Protection: anti-reverse protection
Power Consumption	135mA@24VDC
Internal Bus Supply Current	Max.2.0A@5VDC
Isolation	System power to field power: isolated
Field Power	Power supply: 19.2-28.8VDC (Nominal: 24VDC)
Field Power Current	Max. DC 8A
Number of Supported I/O Modules	32
Wiring	Max.1.5mm ² (AWG 16)
Installation:	35mm DIN-Rail
Size	115*102*82mm
Weight	302g
Environmental parameters	
Operating Temperature of Vertical Installation	-20°C~60°C
Operating Temperature of Horizontal Installation	-20°C~50°C
Relative Humidity	5%~95%RH (no condensation)
Storage Temperature	-40°C~85°C
Storage Humidity	5%~95%RH (no condensation)
Ingress Protection Rating	IP20
EMC Specifications	Comply with IEC61131-2, IEC61000-4
Environmental parameters	
Programming Software	Codesys V3.5.19.70
Programming Language	IEC61131-3(LD、IL、ST、CFC/FBD、SFC)
Maximum Task Status	5
Program Memory	4M Bytes
Data Storage	4M Bytes
Power-down Protection Area	3.9K Bytes
Maximum Expansion Module Input	1K Bytes
Maximum Expansion Module Output	1K Bytes
Bitwise Operations Cycle	0.10us
Word Operation Cycle	0.10us

Double Word Operation Cycle	0.27us
Minimum Program Run Cycle	1ms
RTC	Supported (external battery required)
Communication parameters	
Communication interface	1*RS485, 1*CAN, 3*RJ45+1*RJ45 (Reserved)
Network protocols	Modbus RTU, Modbus TCP, EtherCAT, CANOpen
Network port parameters	10/100Mbps Adaptive, full-duplex
RS485 Interface parameters	2400~115200bps
CAN Interface parameters	10K~1000K bps
Modbus TCP Client	A maximum of 5 Modbus TCP server connections are supported
Modbus TCP Server	A maximum of 5 Modbus TCP client connections are supported
Modbus RTU Master	A maximum of 5 slave devices can be connected
Modbus RTU Slave	Supported
EtherCAT	A maximum of 32 EtherCAT slave devices can be connected
CANOpen	A maximum of 8 CANOpen slave devices can be connected

Note

Please use Codesys V3.5.19.70 for programming software, if use other versions, some functions may differ from the description in the manual, which may cause the device to malfunction or not operate properly.

2.2 Hardware interfaces

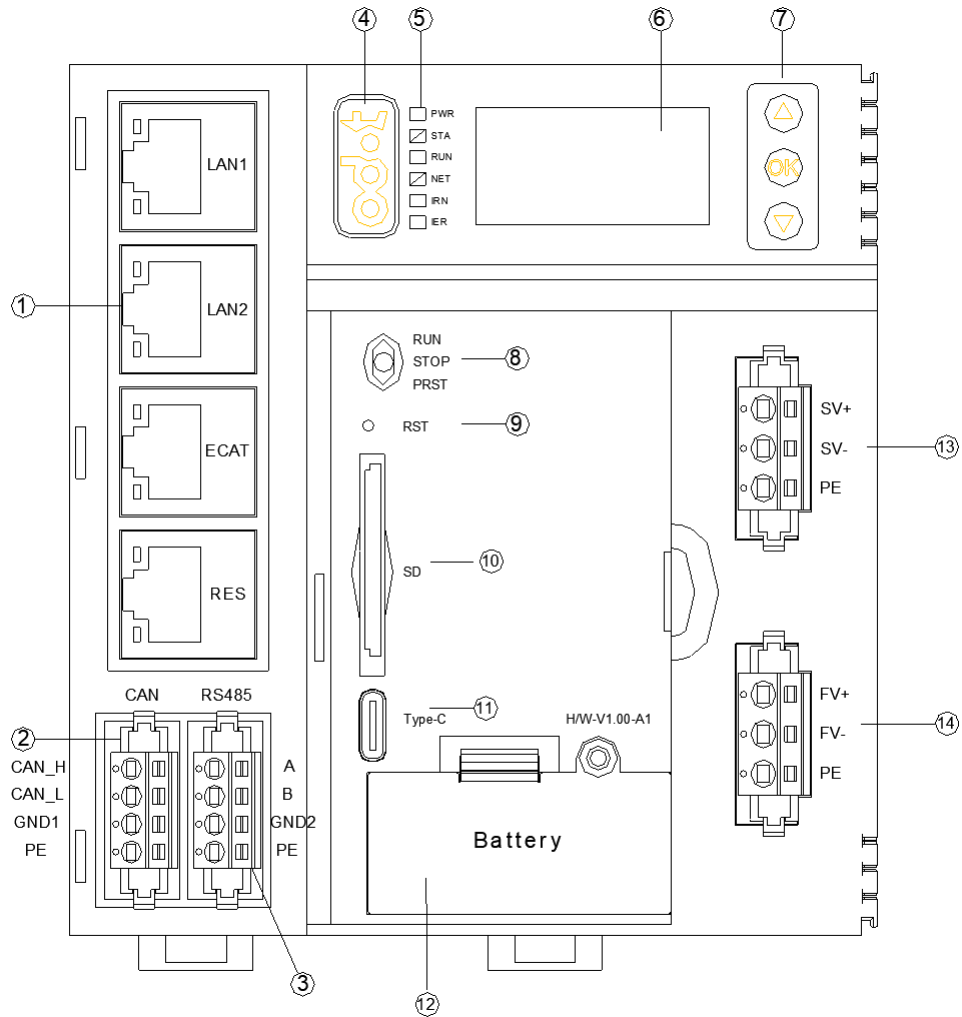

- ① 4 Network interfaces
- ② CANOPEN interface
- ③ RS485 interface
- ④ odot
- ⑤ LED Indicators
- ⑥ Display screen
- ⑦ Display buttons
- ⑧ DIP switch
- ⑨ Reset button
- ⑩ SD card holder
- ⑪ Type-C interface
- ⑫ Battery interface
- ⑬ System power interface
- ⑭ Field power interface

Reset button

Press and hold for 5s during operation to reset the configuration parameters of the C4374 device to its initial state, the default IP address is 192.168.40.74.

DIP switch

1. Dial to the middle to stop the PLC program.
2. Dial to the top to run the PLC program.
3. Press down and hold for 10 seconds to clear the PLC program.

Type-C Interface

This serial port is the information printing port.

LED Indicators



- ① Power indicator (green)
- ② Module Status Indicator (Red/Green)
- ③ Device Operation Indicator (Red/Green)
- ④ Network Status Indicator (Green/Red)
- ⑤ IO Operation Indicator (Green/Red)
- ⑥ IO Error Indicator (Green/Red)

PW Power Indicator (Green)	Definition
ON	The system power supply is normal
OFF	The system power supply is abnormal
STA Module Status Indicator (Red/Green)	Definition
Double Flash (RED)	The module exception has been soft restarted
ON (GREEN)	Run mode
Single Flash (GREEN)	Stop mode
Slow flash (RED/GREEN)	Upgrading mode
Fast flash (RED/GREEN)	Firmware Update
RUN device operation indicator (green/red)	Definition
ON	The PLC is in run mode
OFF	The PLC is in stop mode
NET Network Status Indicator (Green/Red)	Definition
ON (Green)	The current module and PLC configurations are the same
Flash (Red)	The current module and PLC configurations are inconsistent
OFF	inerrancy
IRN IO Operation	Definition

Indicator (Green/Red)	
ON	I/O initialization is normal
OFF	I/O initialization is abnormal
IER IO Error Indicator (Green/Red)	Definition
OFF	I/O communication is normal
Double Flash	I/O communication is abnormal

OLED

Displays information such as device name, IP address, APP, IAP version number, and error code.

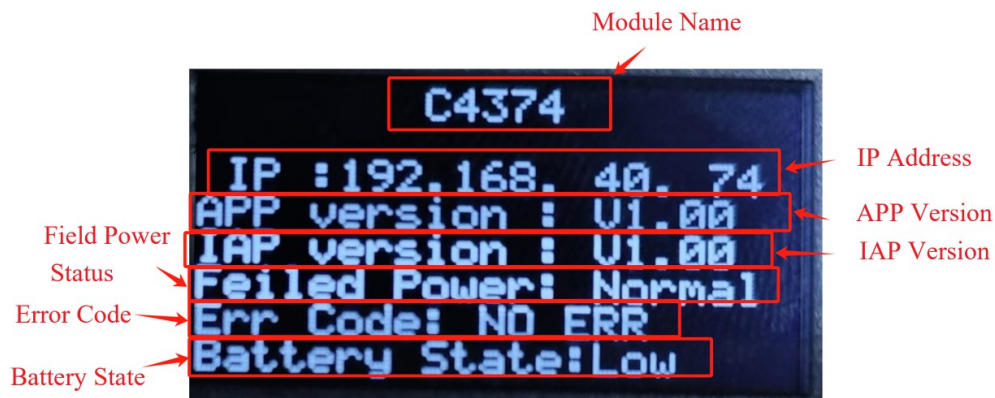

2.3 Wiring

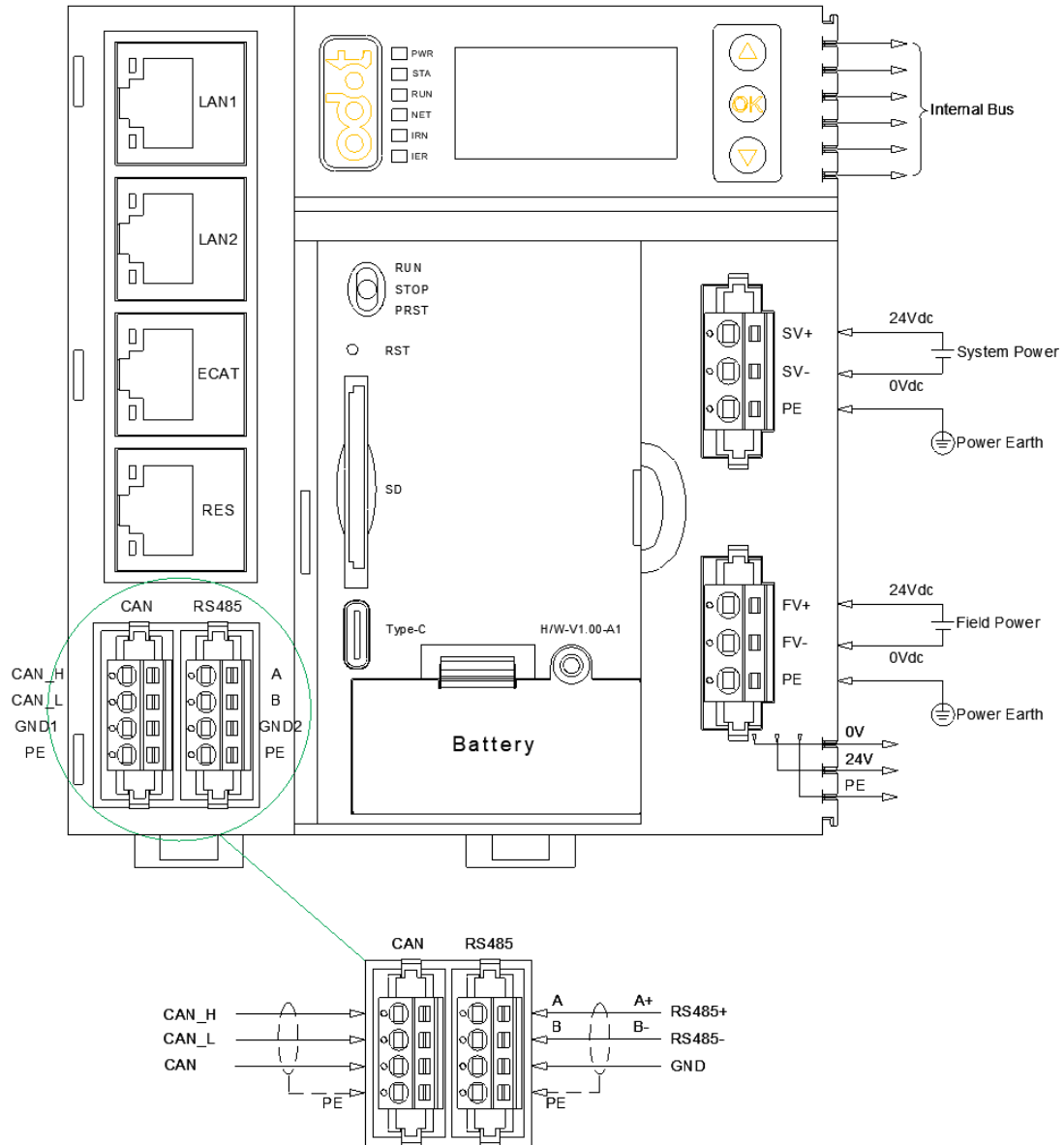

Ethernet interface

The C4374 has 4 Ethernet interfaces, Port 1/Port 2 can be used as Modbus TCP and IO Config interface, Port 3 is EtherCAT communication interface, Port 4 is reserved interface.

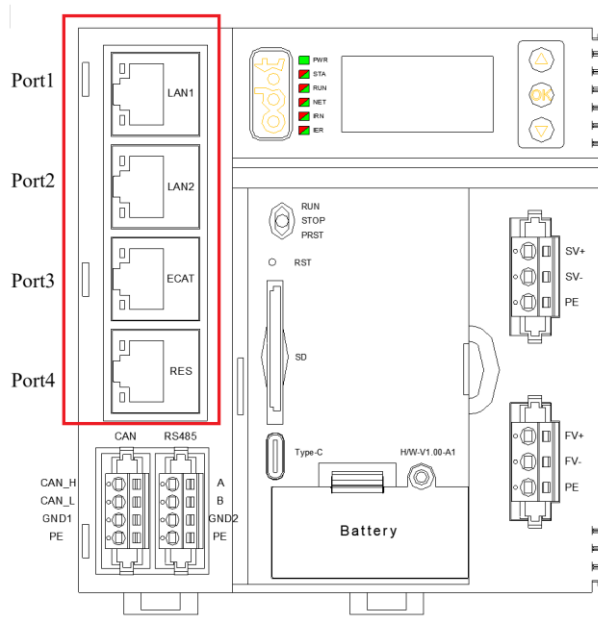

LAN1/LAN2 support switch function, 10Mbps/100Mbps adaptive rate, it can be used as Modbus-TCP and IO Config interface.

Speed Network Speed Indicator (Green)

ON: 100Mbps

OFF: 10Mbps

Link/Act Link status indicator, Active indicator (Orange)

ON: Connected

OFF: Not connected

Flash: Active connection

SHIELD RJ45 Crystal head shield interface

RJ45 Interface pin definition:

Pin	Definition	Description
1	TD+	Transmitter Signal Positive
2	TD-	Transmitter Signal Negative
3	RD+	Receiver Signal Positive
6	RD-	Receiver Signal Negative

RS485 Interface

The device wiring uses 4PIN terminals, the pins definition as follows:

Pin	Definition	Description
1	A+	RS485 A+

2	B-	RS485 B-
3	GND	Signal Ground
4	PE	Protect Earthing

 **WARNING**

UNEXPECTED DEVICE OPERATION

• RS485 INTERFACE ACCESS TO MORE THAN THE RATED VOLTAGE CAN CAUSE PERMANENT DAMAGE, THE RATED VOLTAGE IS DC ±5V

FAILURE TO FOLLOW INSTRUCTIONS MAY RESULT IN SERIOUS CONSEQUENCES SUCH AS DEATH, PERSONAL INJURY, OR DAMAGE TO EQUIPMENT.

CANopen Interface

The wiring of the equipment adopts 4PIN terminals, and the terminal definitions are as follows:

Pin	Definition	Description
1	CANH	CAN H
2	CANL	CAN L
3	GND	Signal Ground
4	PE	Protect Earthing

Power Interface

It is powered by 24V DC and uses 3PIN terminals.

The system power pins are defined as follows:

Pin	Definition	Description
1	SV+	System power positive
2	SV-	System power negative
3	PE	Protect Earthing

The field power pins are defined as follows:

Pin	Definition	Description
1	FV+	Field power positive
2	FV-	Field power negative
3	PE	Protect Earthing

2.4 Dimension

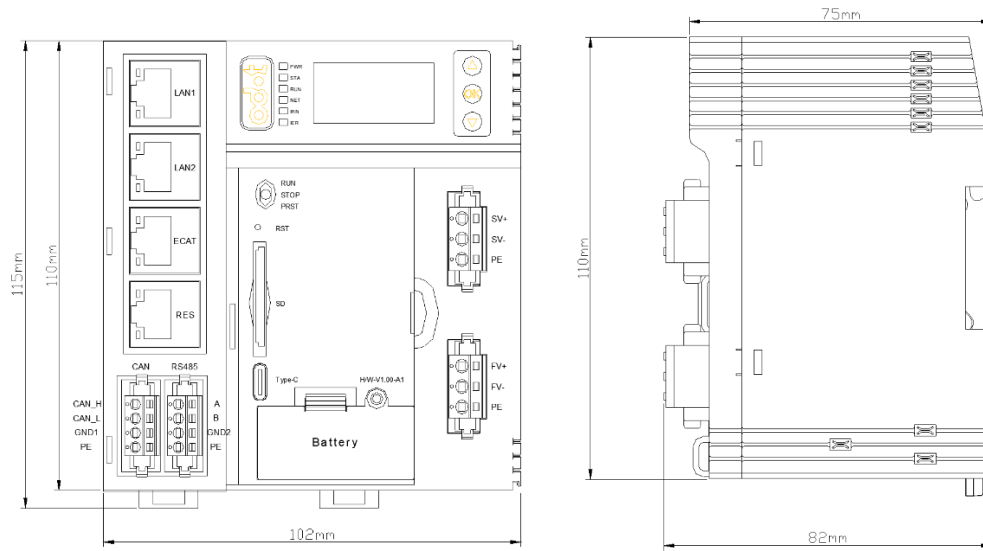

3 IO Config Software

3.1 IO Config Software Installation

Double-click the icon to click Install, in the pop-up window you can choose to configure the language of the software, English and Chinese Simplified are optional, select the English, click OK.



In the pop-up window, confirm the installation directory in turn, click 'Next', check the Create 'Desktop icon', click 'Next', and click 'Install'. After the installation is complete, an IO-Config shortcut icon is generated on the desktop.

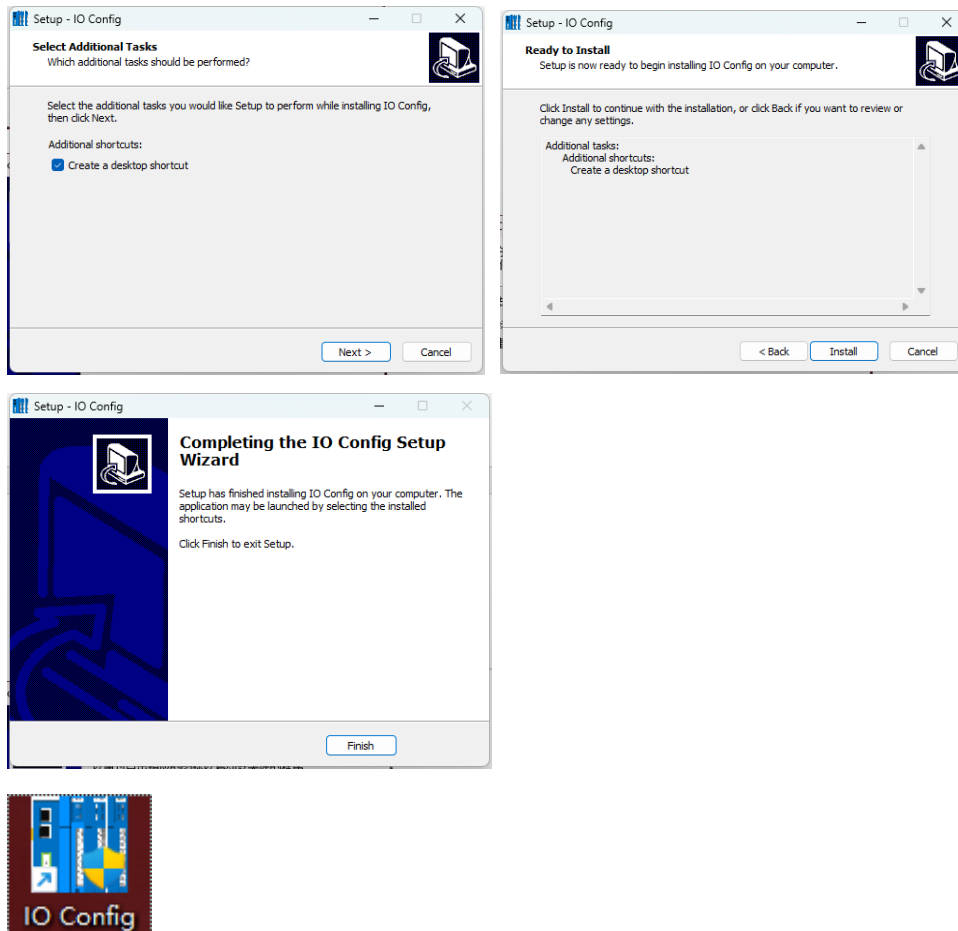

3.2 Software interface

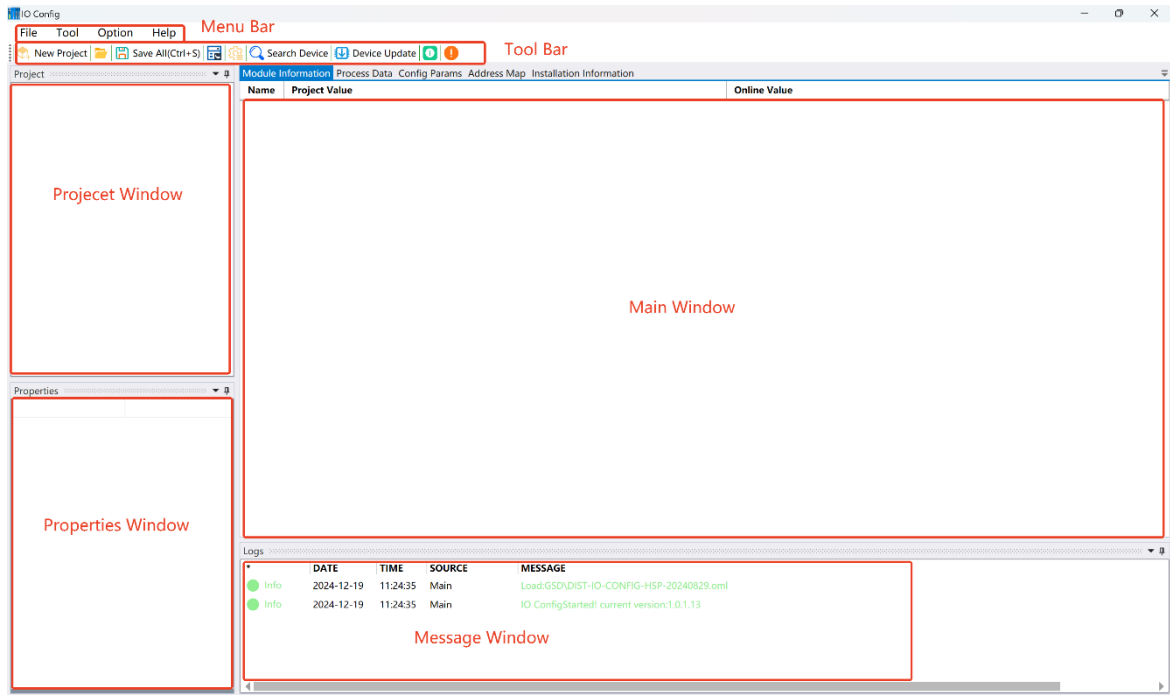

Menu Bar: The menu of IO Config software.

Toolbar: Commonly used user menus.

Project Window: Displays the currently established projects.

Properties Window: Displays the specific parameters of the current project.

Main Window:

Basic Information: it can view the module name, module number, hardware version, software version, module description, current consumption, and device manufacturer of the module.

Process data: Can be used to monitor channel data online.

Configuration Parameters: modifiable module parameters.

Address Table: The address area occupied by the I/O module.

Installation information: it can view the module description, current consumption, module size, residual current, and product pictures.

Message window: output the operation log of the current operation.

Menu bar

File

Menu	Submenu	Description
Project	Create new project	Create a new project
	Open project	Open a saved project
	Save all	Save the current project
	Save As	Save the current project as a new project
Exit		Exit the software

Tool

Menu	Description
Search Device	A new window pops up to search for devices by network or serial communication
Device Update	A new window pops up for the C4374 device and I/O module firmware upgrade

Option







Menu	Description
Configuration	It can modify the software display language, software interface display color, and device library description file path



Help

Menu	Description
About	It can view the company information and the version number of the configuration software
About Exception	A new window pops up, an abnormal exit reminder, please install Microsoft patches for Windos7 Sp1/XP and the following versions.

Toolbar

Menu general shortcut icons:

Icon	Name	Menu	Description
	New Project	File-Project-New Project	Create a new project
	Open Project	File-Project- Open Project	Open a saved project
	Save All	File-Project- Save All	Save the current project
	Save As	File-Project- Save As	Save the current project as a new project
	Config	Option- Config	Modify the display language, accent color, and device library description
	Search Device	Tool- Search Device	A new window pops up, search for the device

	Device Update	Tool - Device Update	A new window pops up for module firmware upgrade
	About	Help- About	To view the information, you can view the version number of the configuration software
	About Exceptions	Help - About Exceptions	A new window pops up, an abnormal exit reminder, WIN7 sp1/XP system versions below please install Microsoft patches.

Properties window

Displays the currently established projects.

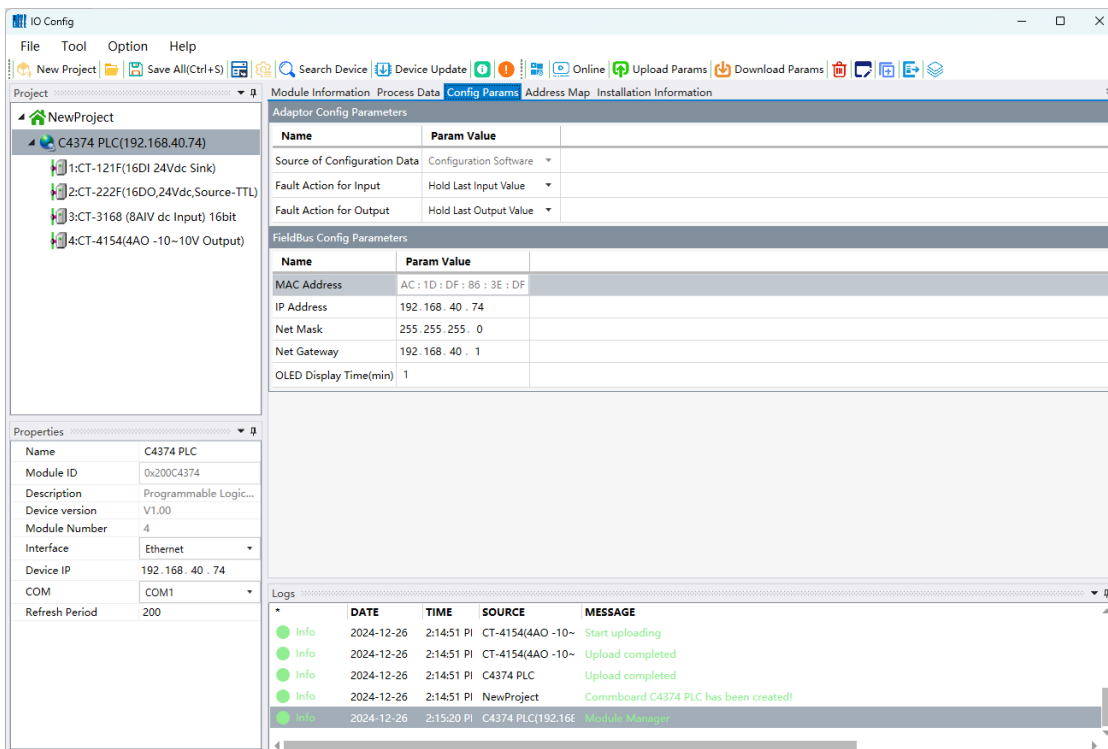

Properties window

The Properties window displays the specific parameters of the current item.

PLC (module name, module number, module description, device version, number of modules, interface selection, device IP address, serial slogan, online refresh cycle).

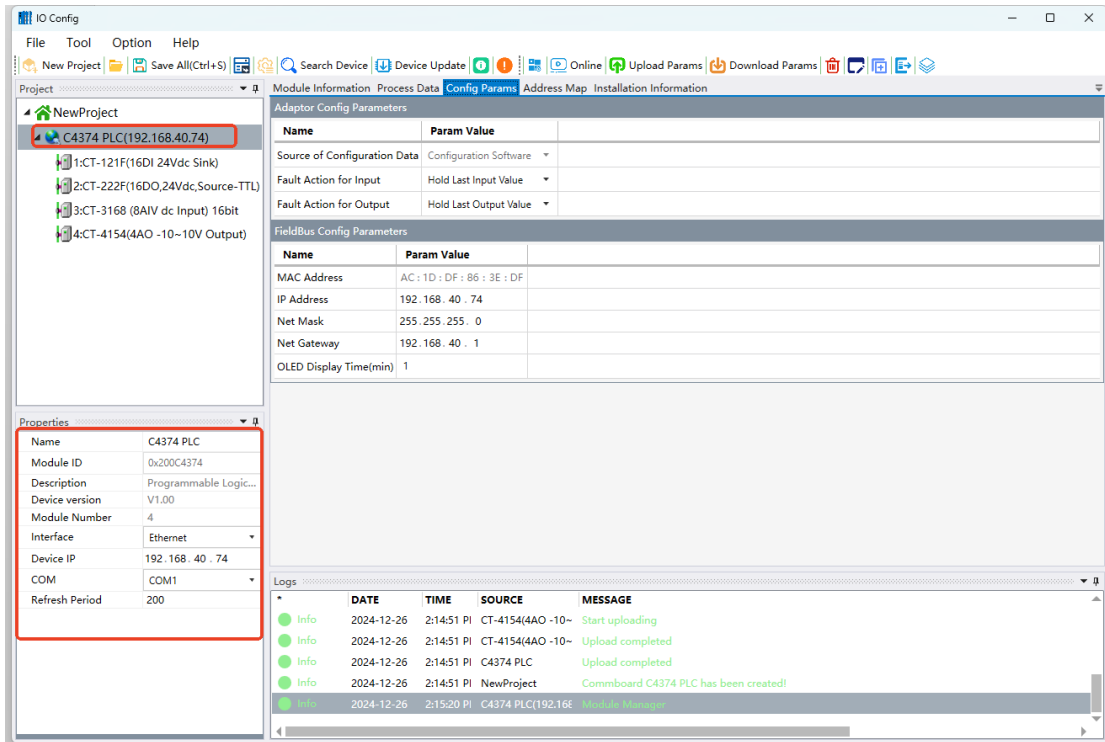

I/O module (module name, module number, module description, number of submodules)

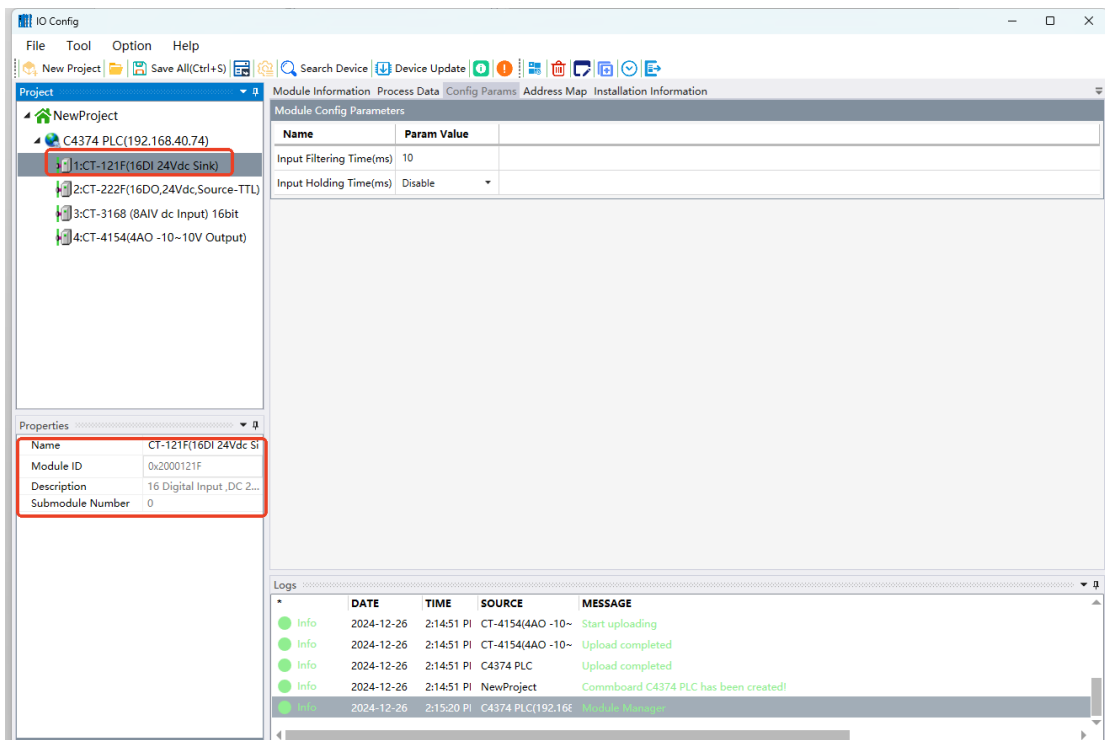

Main window

Basic information: It can display the module name, module number, hardware version, software version, module description, current consumption, and equipment manufacturer of the PLC and I/O modules.

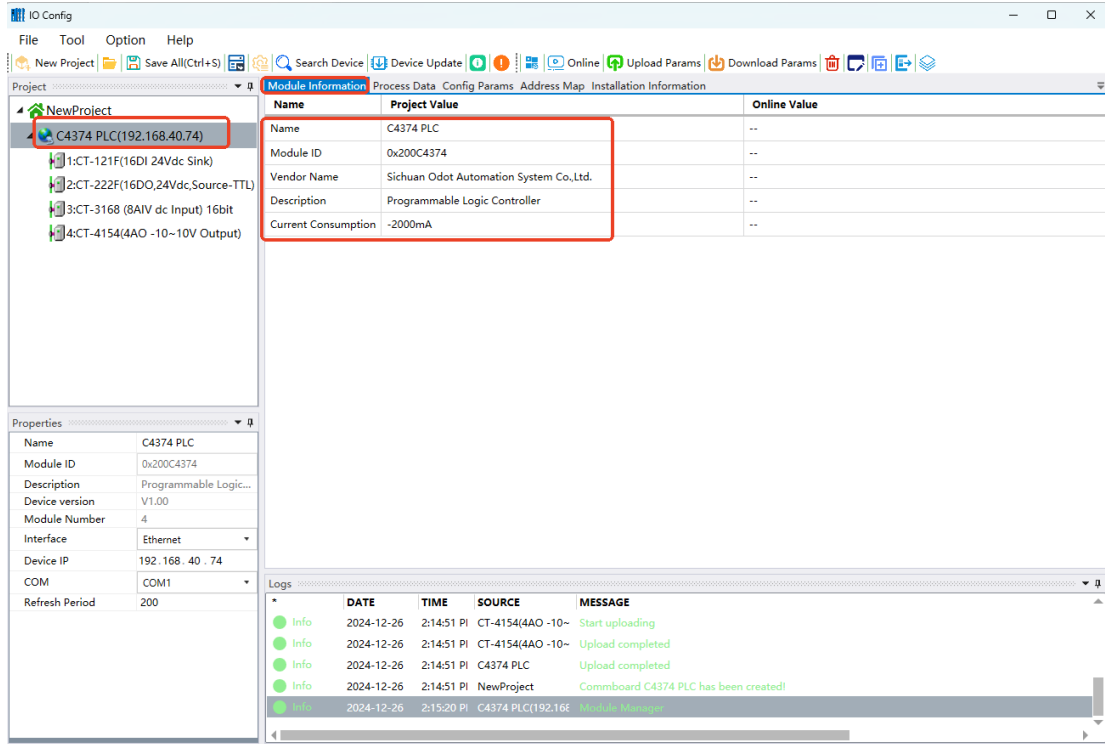

Process data: Displays the channel information of the I/O module for online monitoring of the channel data.

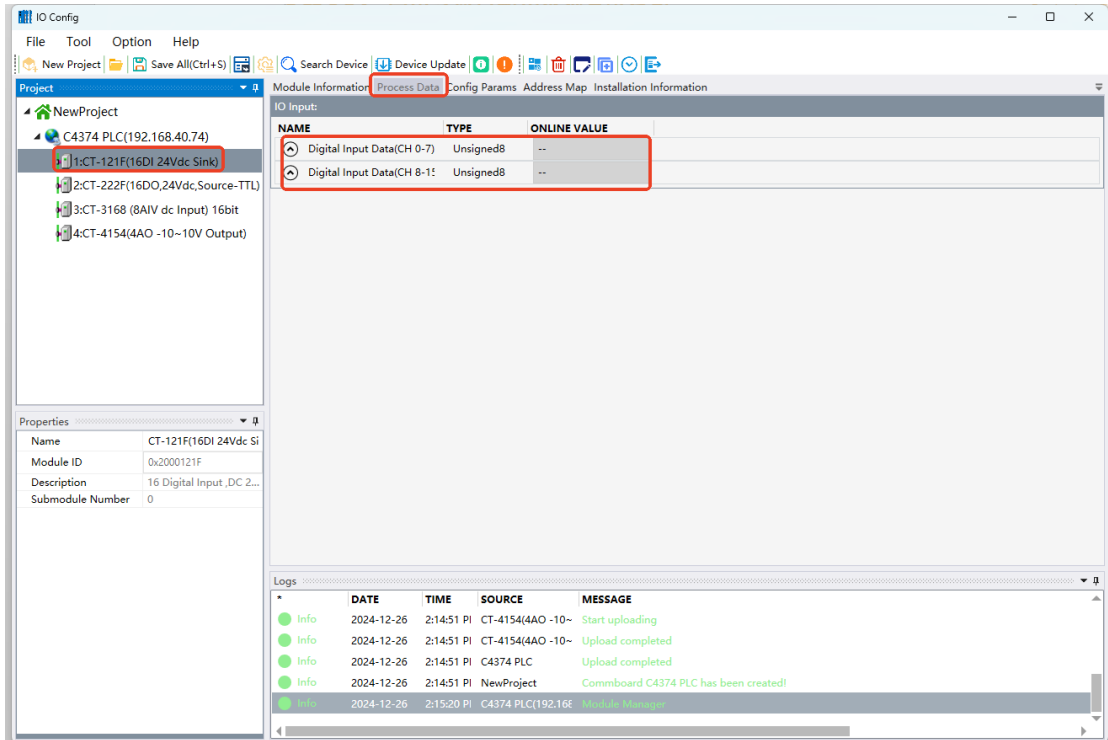

Configuration Parameters: Displays the module parameters of the PLC and I/O modules, and the module parameters that can be modified.

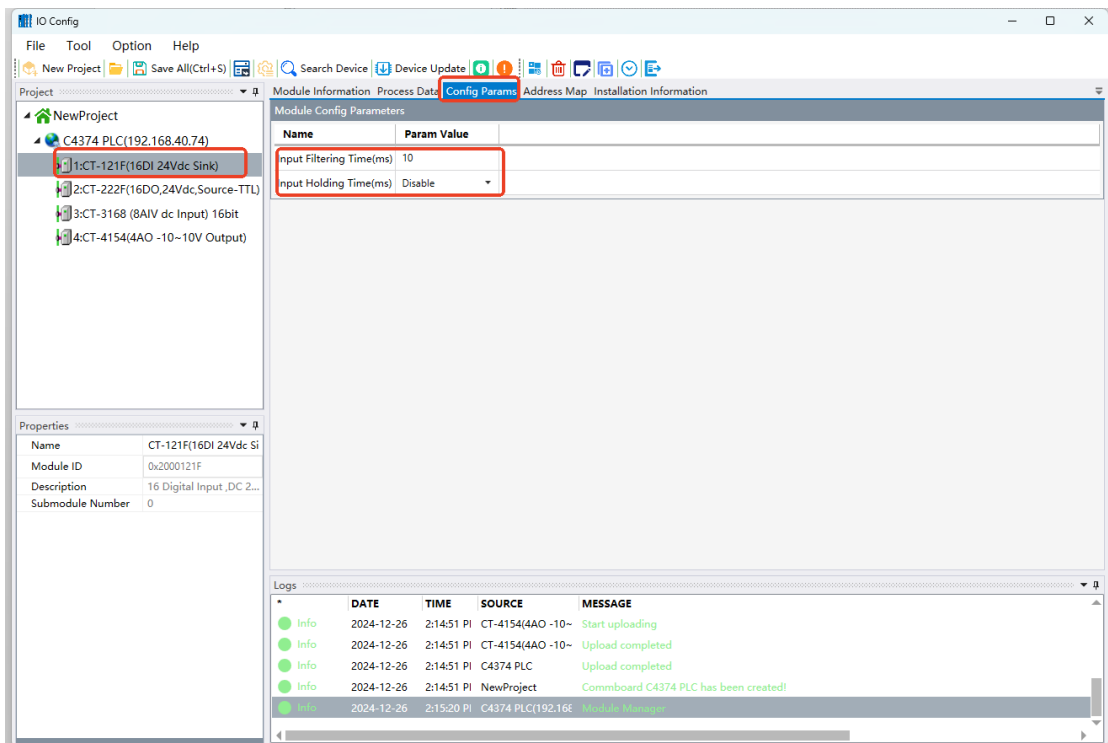

Address Table: Displays the storage area where the input and output channels of the I/O module are located.

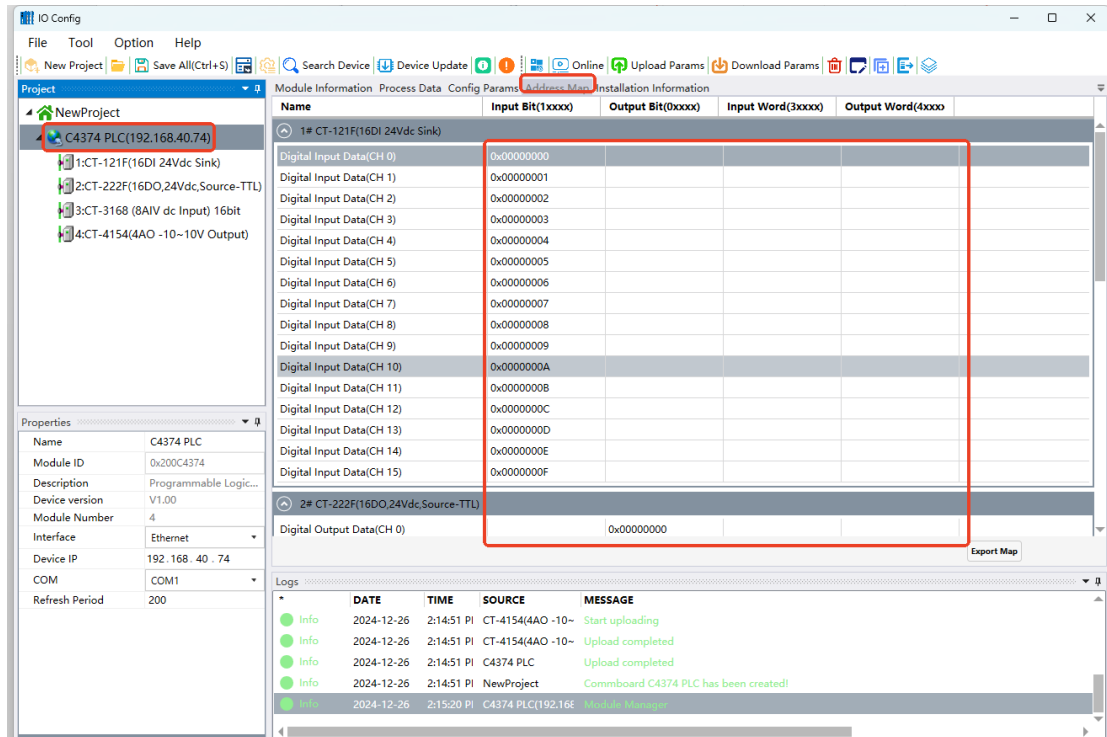

Installation information: It can display the module description, current consumption, module size, residual current, and product pictures of PLC and I/O modules.

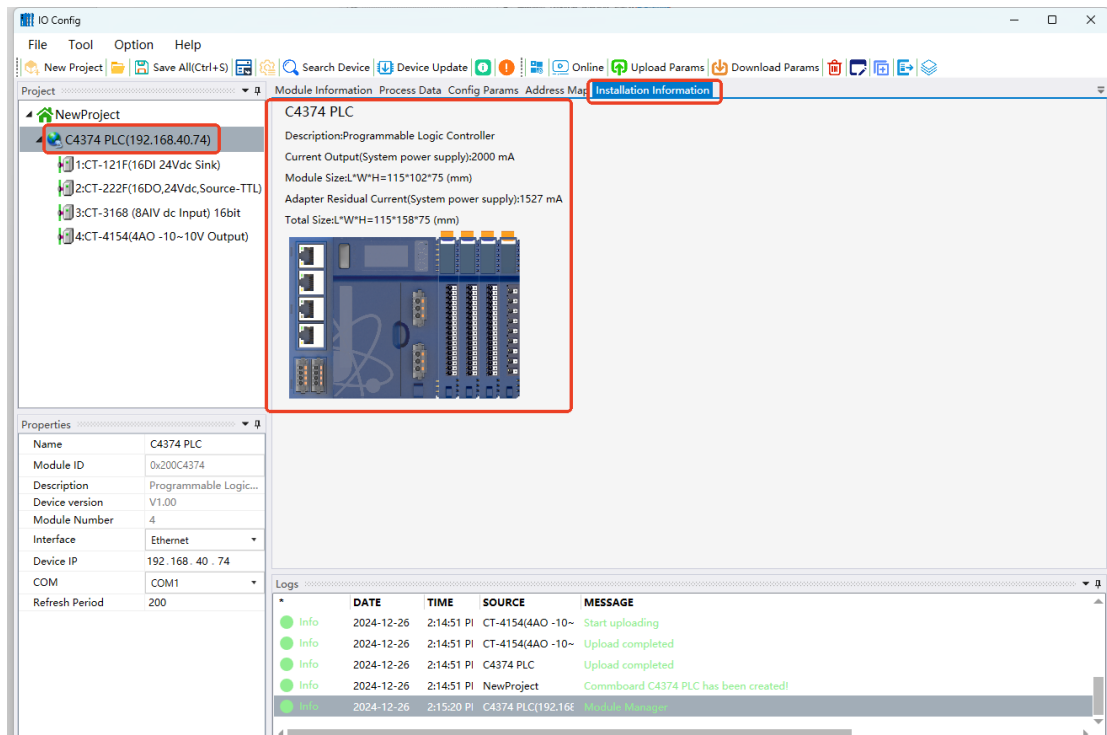

Message window

Displays the real-time information of the current operation, and displays all operation log records such as creating a new project, uploading, downloading, modifying

configuration parameters, and copying and pasting output.

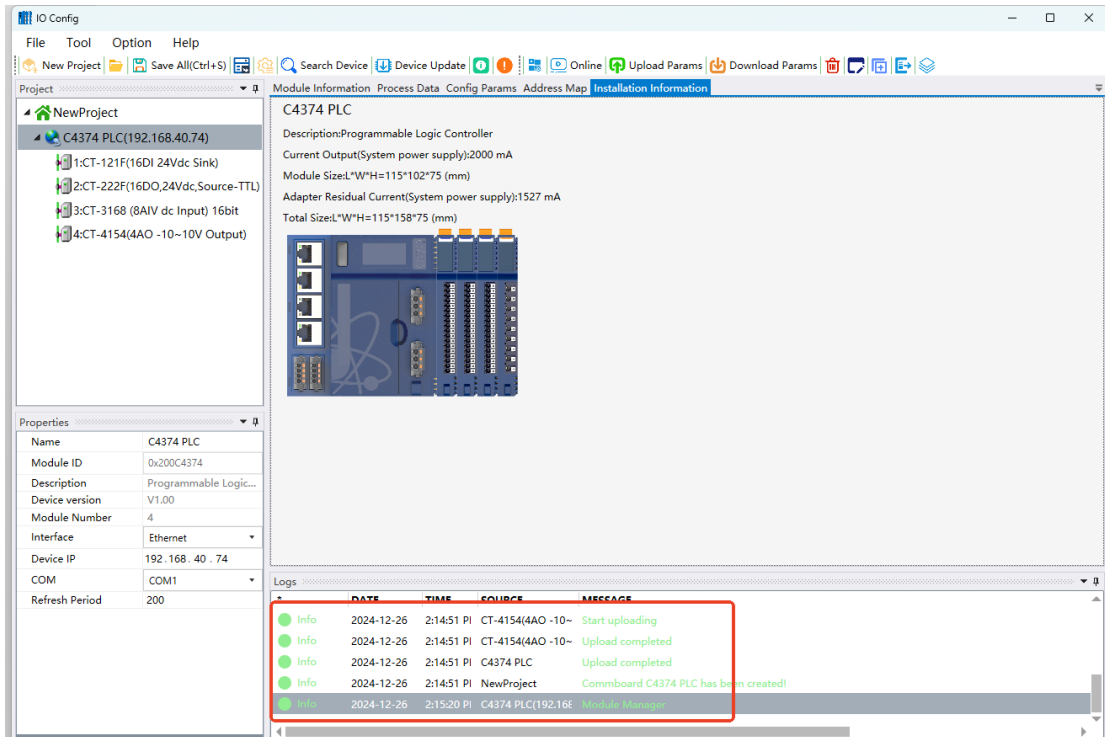

Shortcut key

Shortcut Key	Menu	Description
Ctrl + C	Project/PLC, Adapter-copy	Copy project, PLC, adapter and I/O modules
Ctrl + V	Project /PLC, Adapter -paste	Paste project, PLC, adapter and I/O modules
Delete	Project /PLC, Adapter -delete	Copy project, PLC, adapter and I/O modules
Ctrl + S	File-Project-save all	Save the configuration project
Ctrl + M	PLC, Adapter-Export Map	Export the PLC, Adapter and I/O modules map

3.3 Software function

Function

- A. Module selection.
- B. View the module configuration parameters and the data address of the module.
- C. Modify the module configuration parameters.
- D. Online debugging module.
- E. Search for the device.
- F. Firmware Upgrade.

Communication interface

The C4374 uses the Ethernet interface as the communication interface for uploading and downloading I/O modules, uploading and downloading I/O modules, modifying the parameters of mounted I/O modules, online testing, and firmware upgrades.

View the configuration parameters

For C4374 devices and different I/O modules, click Configuration Parameters to view the default configuration parameters of the module.

C4374 Default Parameter Interface:

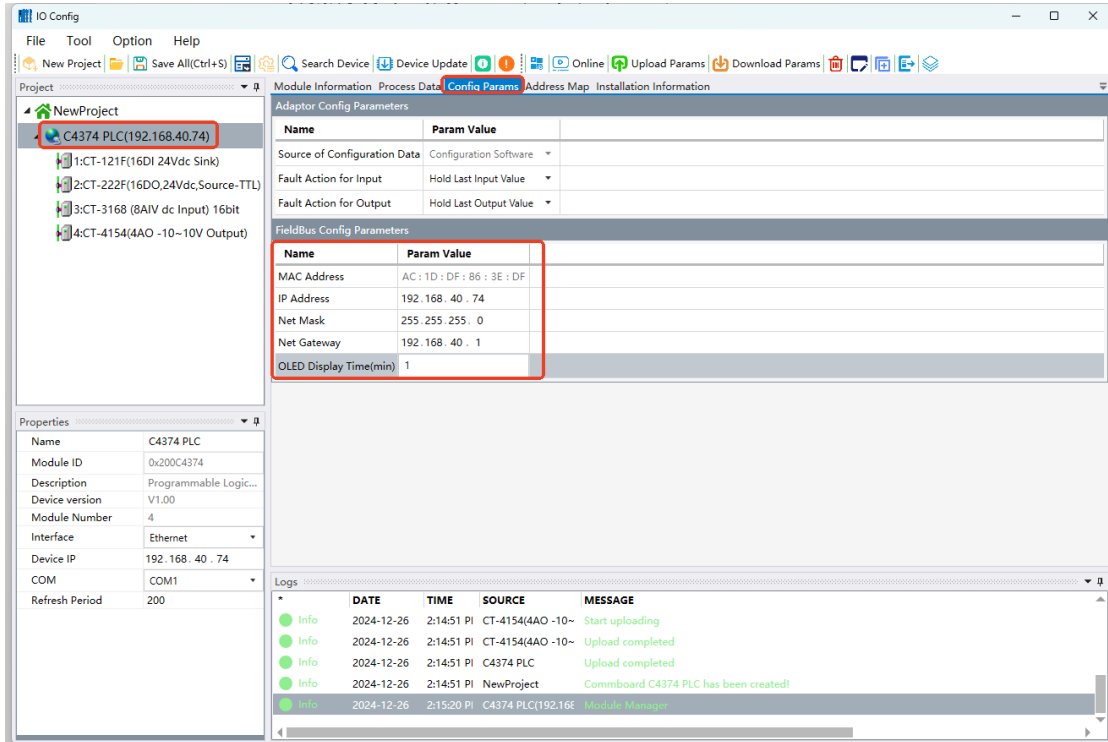

The I/O module uses the 16DO module (CT-222F) as an example, and the default parameter interface is as follows, and the configuration parameters of other I/O modules are viewed in the same way.

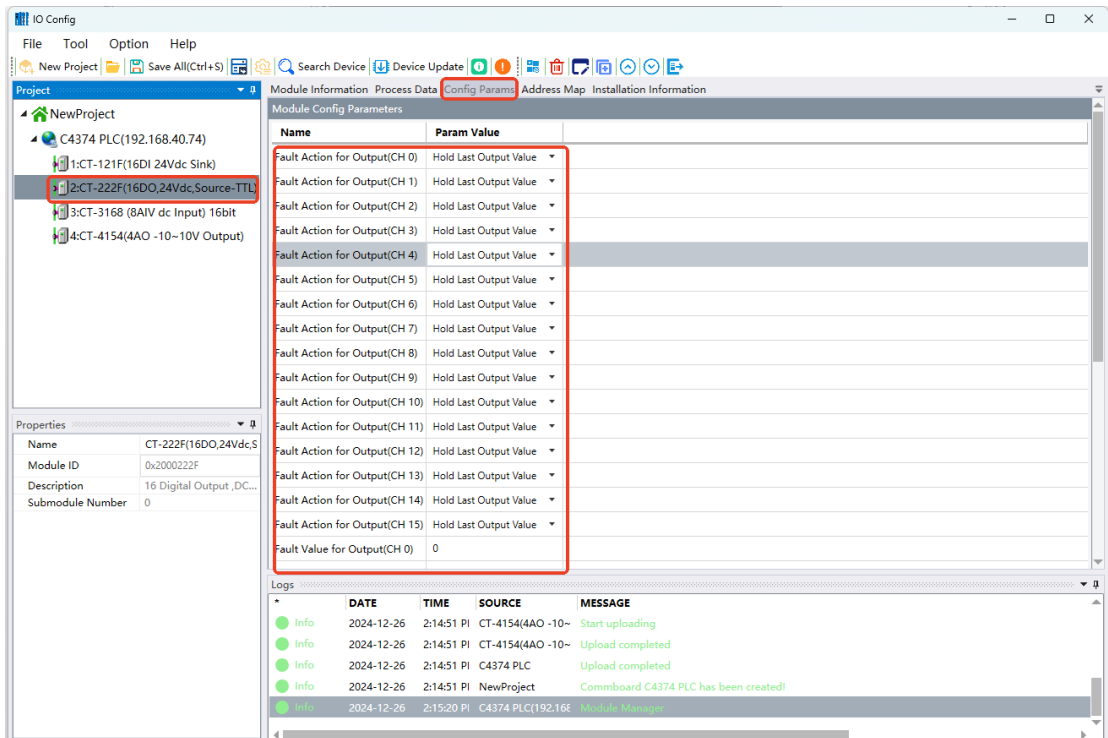

Modify the configuration parameters

The configuration parameters of the C4374 and I/O modules can be modified in the IO-Config software. C4374 parameters must be modified with the help of IO-Config software.

Use C4374 PLC, CT-121F, CT-222F and other modules to demonstrate the configuration of module parameters.

The C4374 uses the Ethernet configuration interface, click Search for Devices, and follow the steps shown below to upload the device.

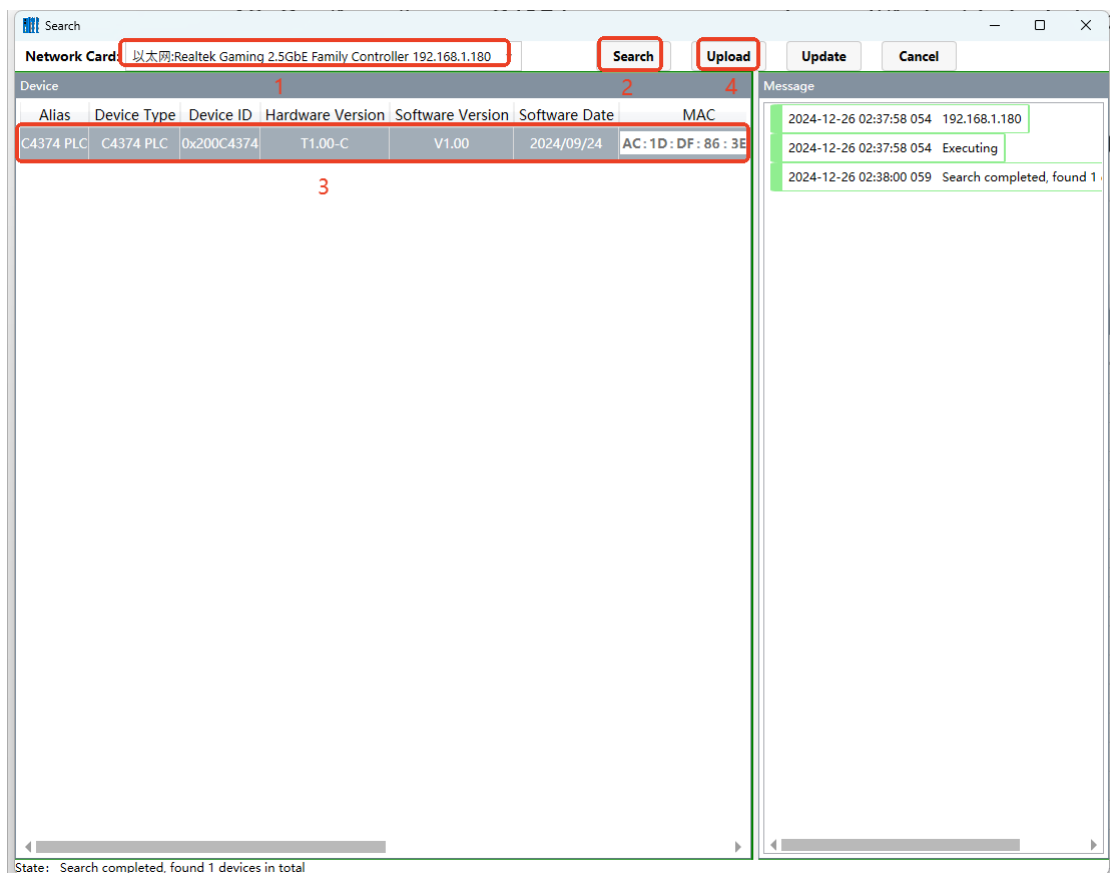

The software will automatically create the project, as shown in the following figure.

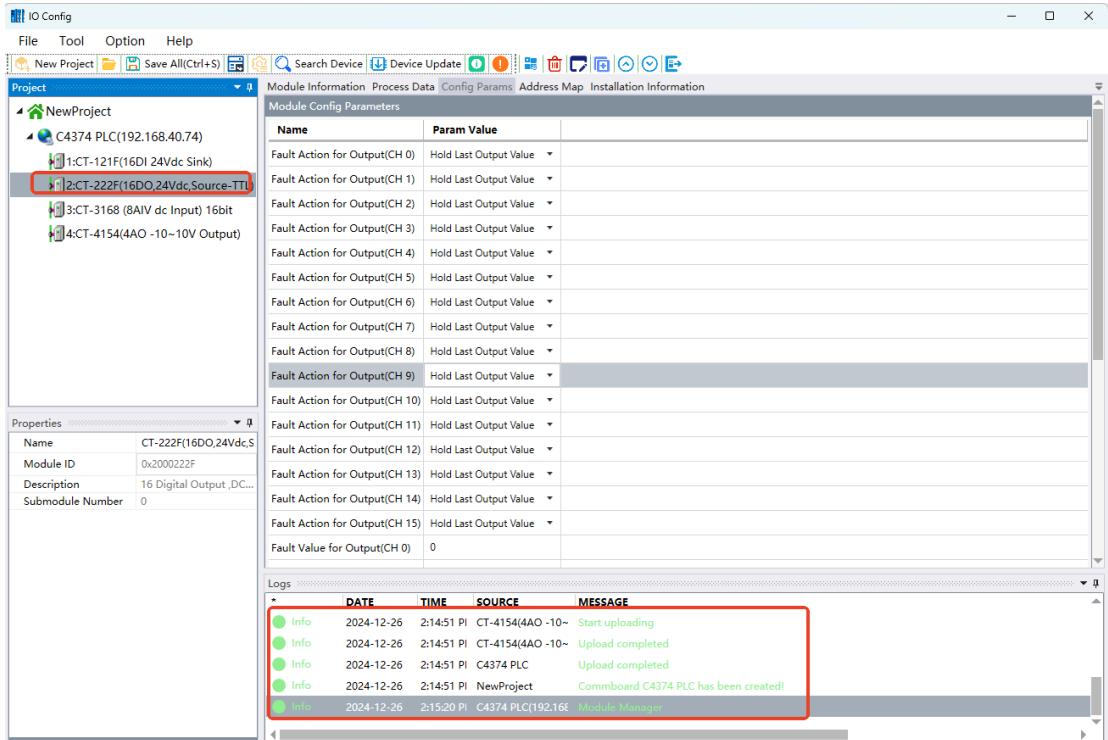

Then modify the parameters of the module.

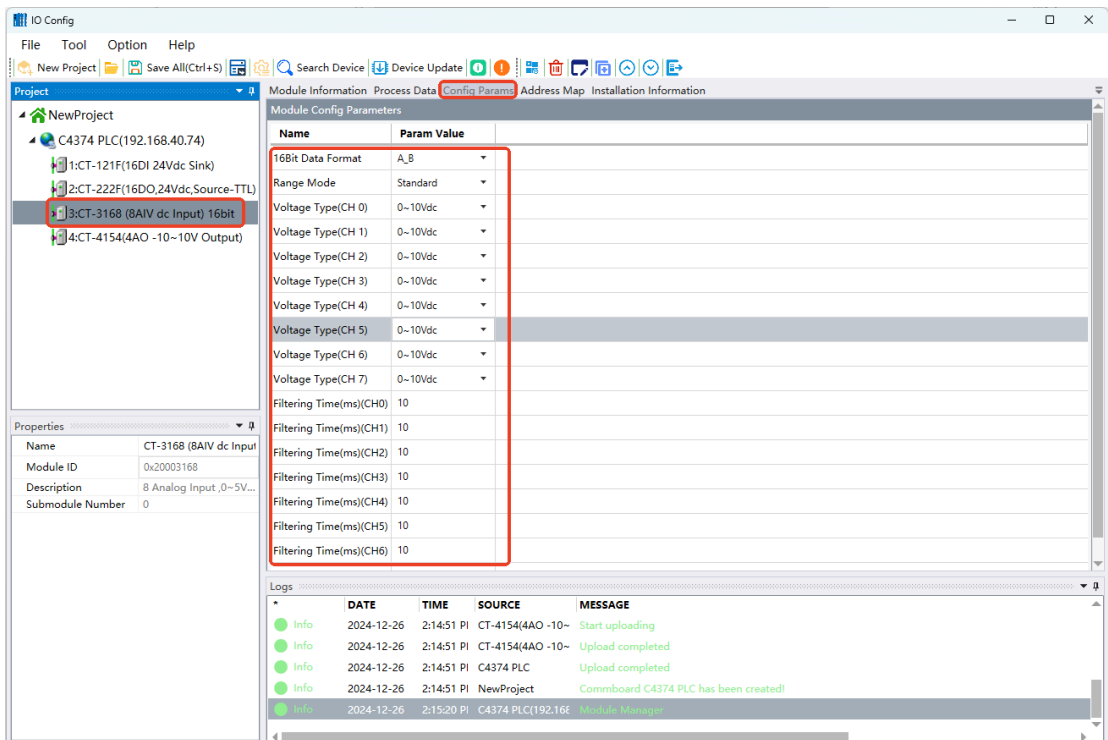

After the settings are complete, right-click the C4374 device in the project directory bar – "Download Configuration". The configuration parameters of the C4374 device and I/O module can be modified.

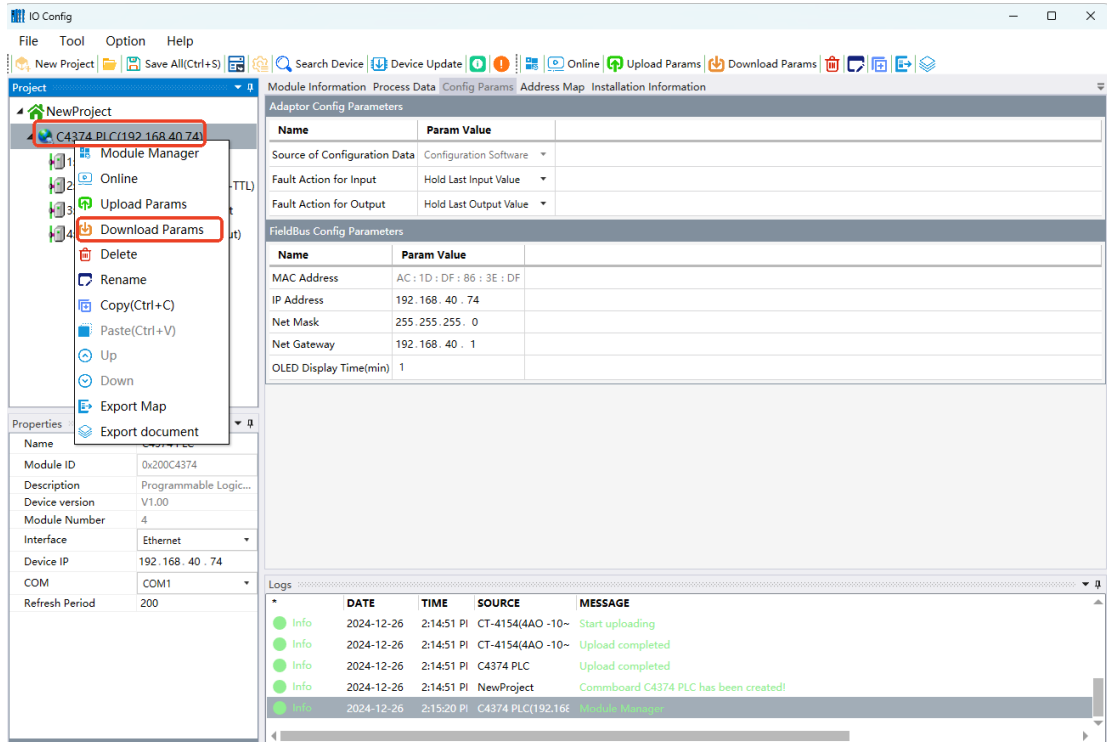

After all module parameters are modified, click the shortcut key 'Save All' or press the keyboard shortcut 'Ctrl +S' to save the entire configuration project file.

Online Debug

First, search for the device and upload the project, right-click on the C4374 device, and select Online. The I/O module real-time data can be monitored in the "Process Data" interface of the main window.

For example, the CT-222F module in slot 2 can be used to view the real-time changes of the I/O point.

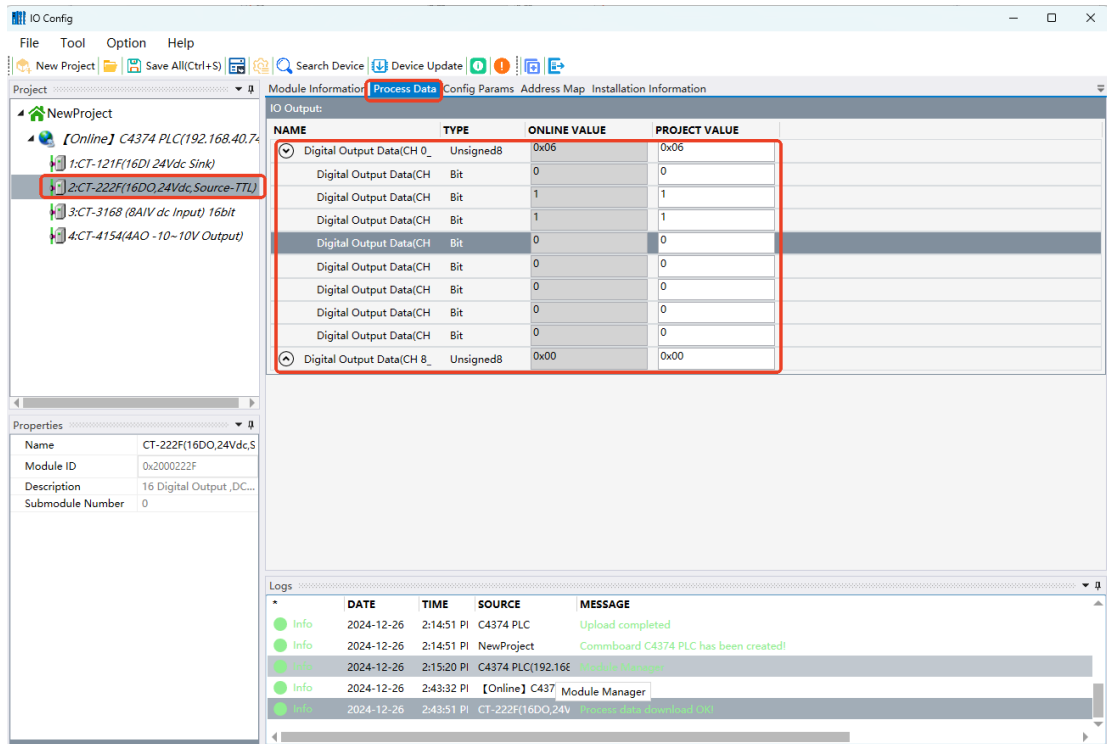

Note: For digital input modules, it can right-click on the module and manually add the 'Counting Submodule'. After the addition is complete, you must download the configuration again.

Device firmware upgrade

Open the IO-Config software, click Search for Devices, and follow the steps shown below.

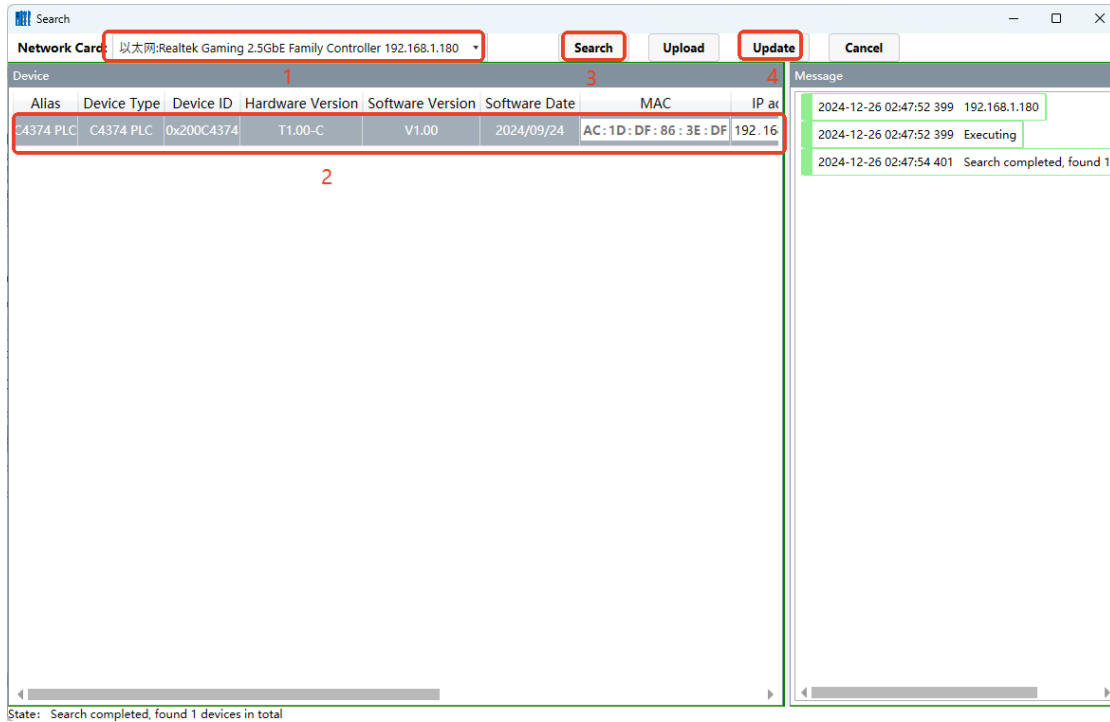

In the pop-up interface, set the upgrade file, select the interface and set 'Ethernet', then 'Read Device Information', check the devices to be upgraded, set 'Auto Jump', and then click 'Start Upgrade' and wait for the upgrade to complete.

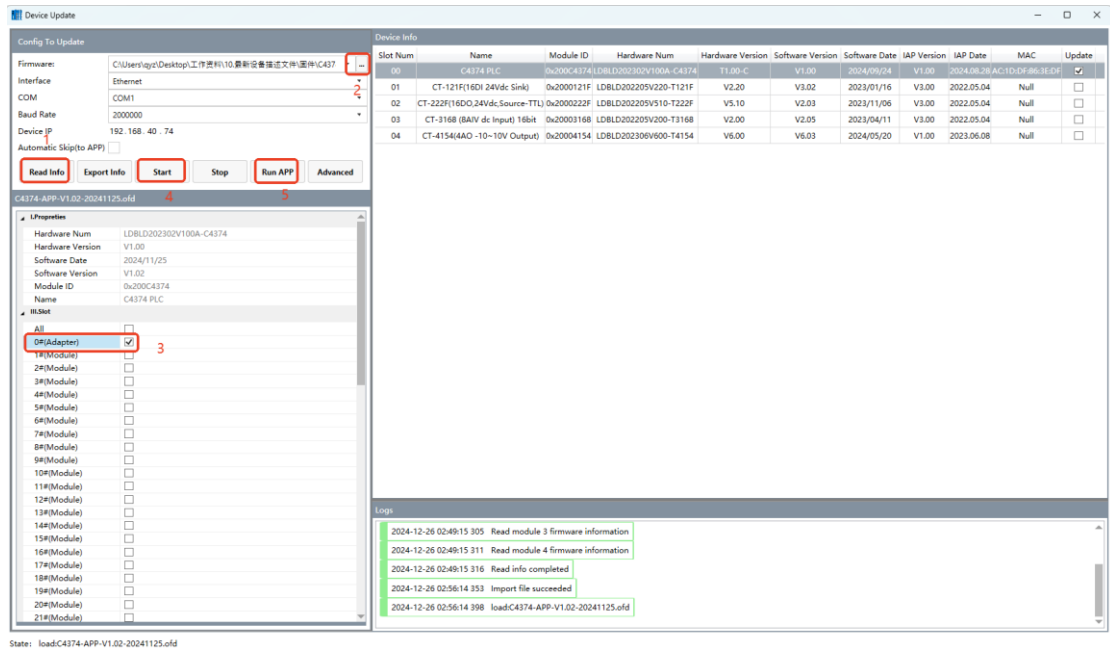

The above is the process of firmware upgrade, and the I/O module can be upgraded using this method.

Data export

Right-click on 'C4374 Device' and select 'Export Address Table'.

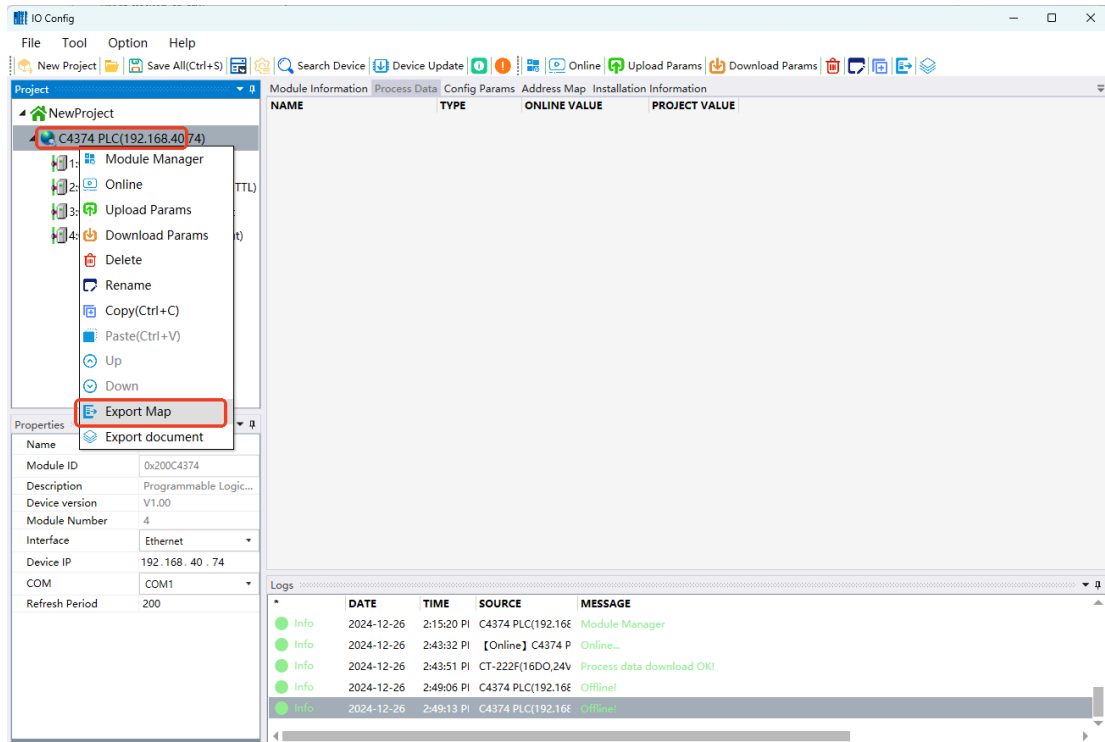

In the pop-up window, select the file format, output file directory, and file name, and then click Confirm.

Export Document After creating the project, right-click on the C4374 device and select Export Document.

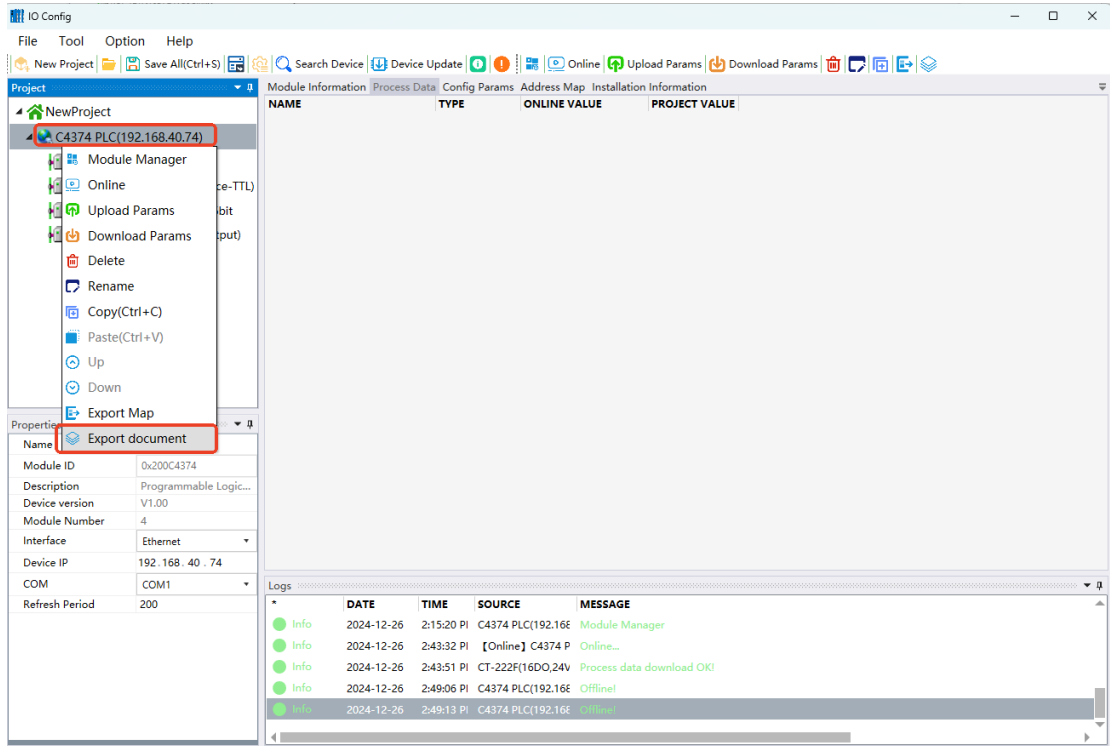

In the pop-up window, select the file format, output file directory, and file name, and then click Confirm.

4 Programming software (Codesys)

4.1 Programming software installation

The CODESYS V3.5.19.70 programming software can be downloaded from the CODESYS website or installed according to the software installation package provided by the company. The SP19 version is used as an example for installation and demonstration. Log in to the www.codesys.cn, then find the download section and click:

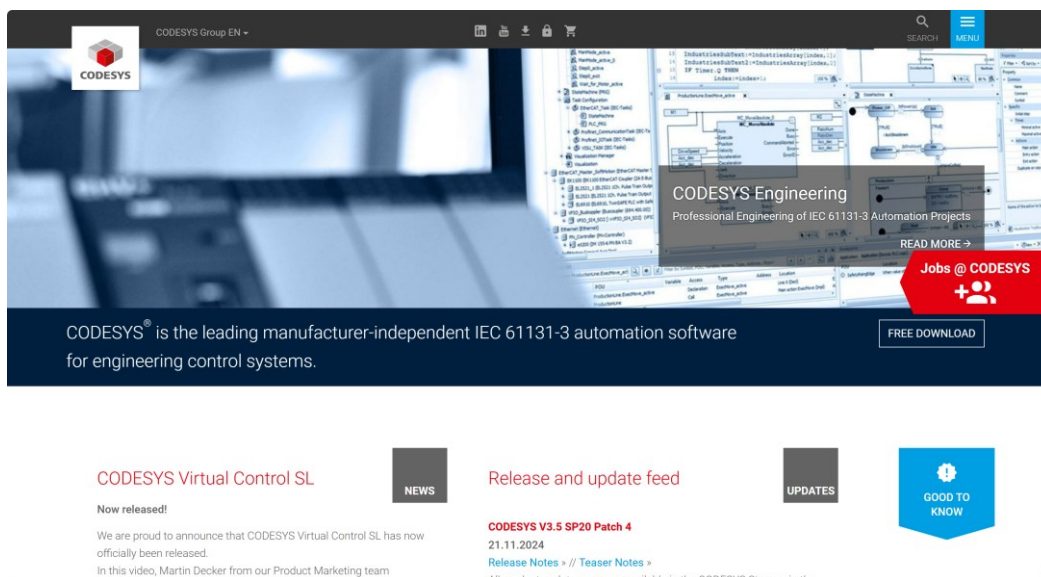

Then enter the download page, and select the appropriate installation package to download according to the configuration of the computer:

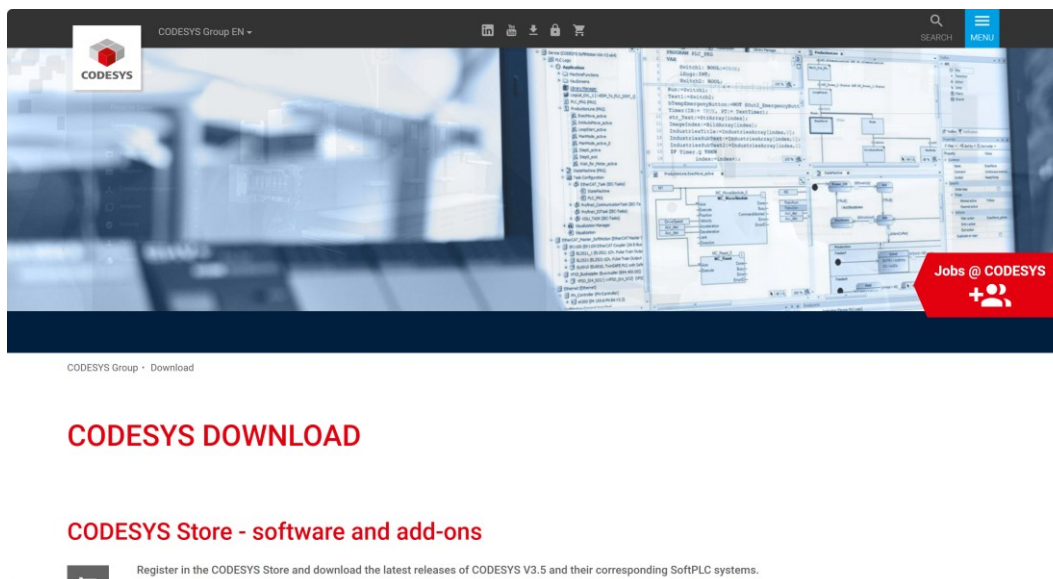

After the download is complete, double-click the installation package and follow the steps in the pop-up window:

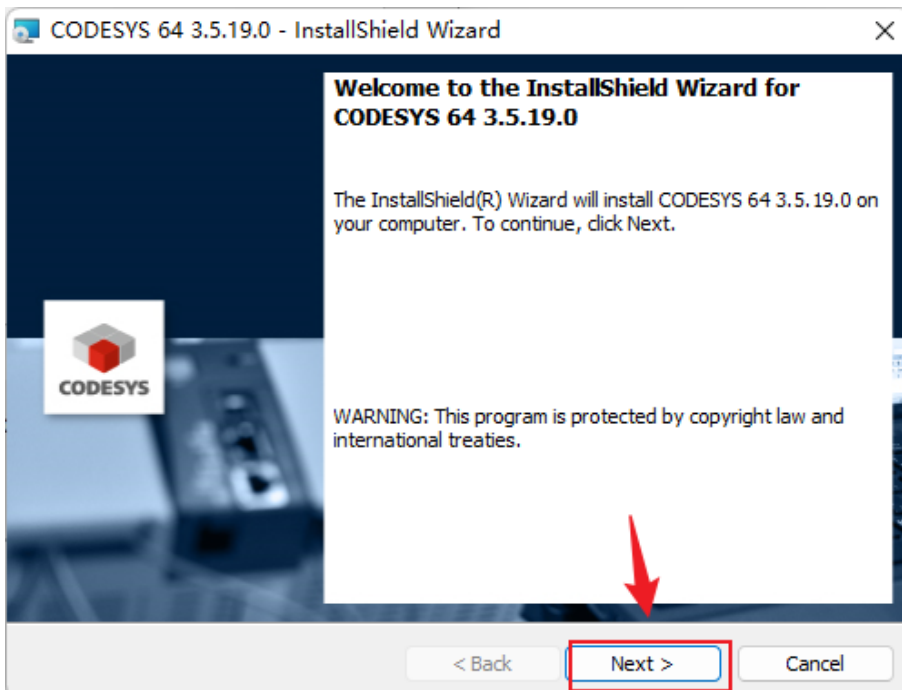
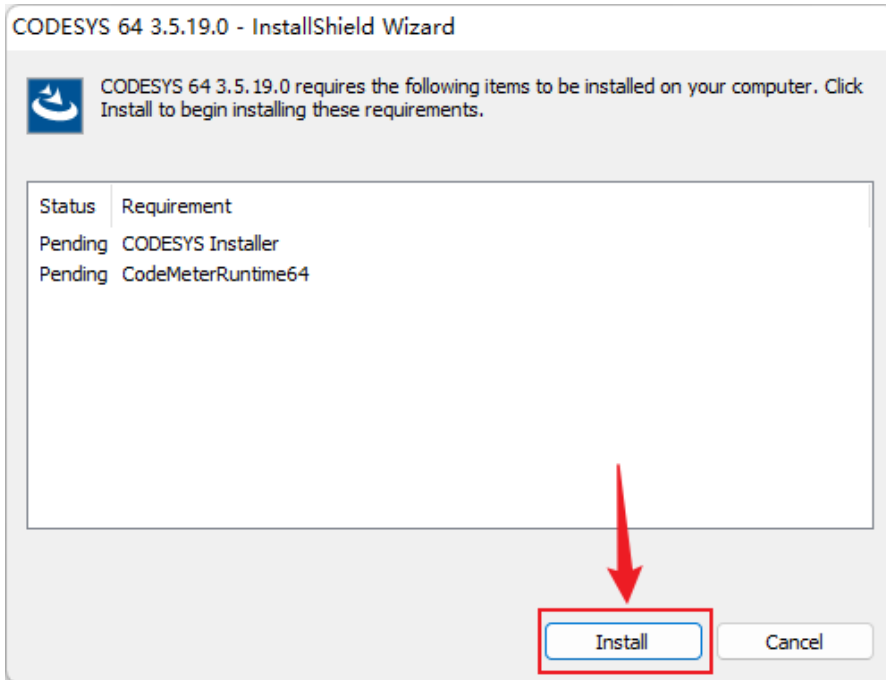

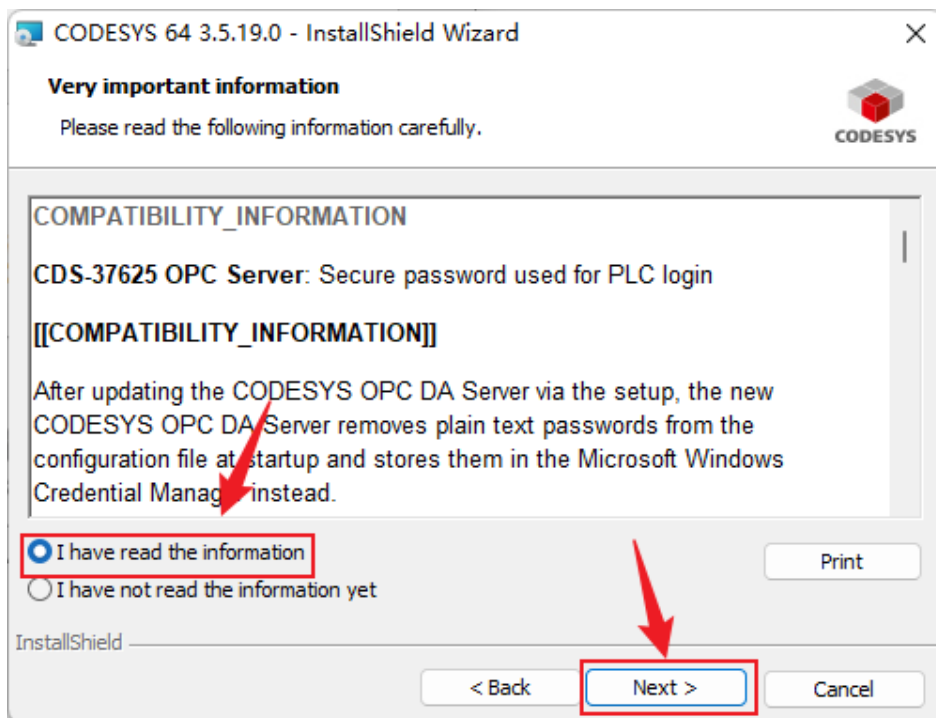
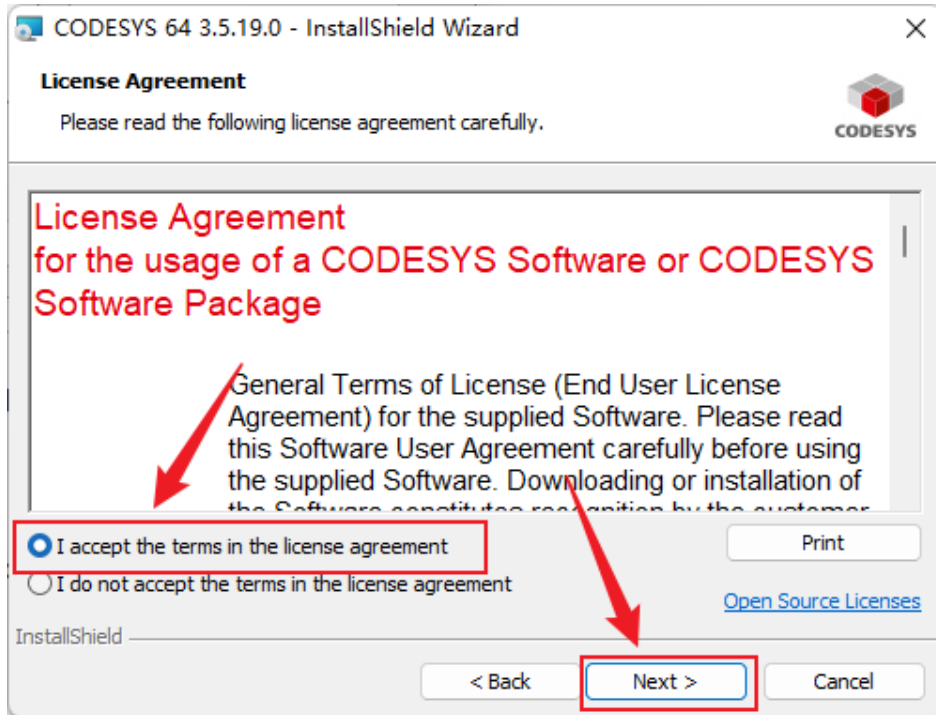

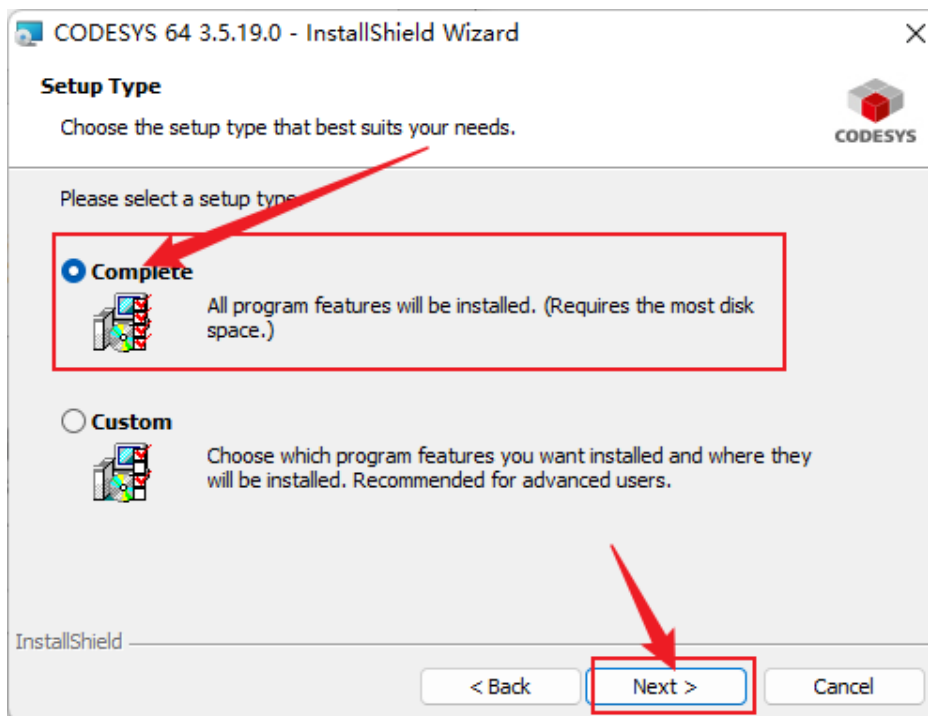
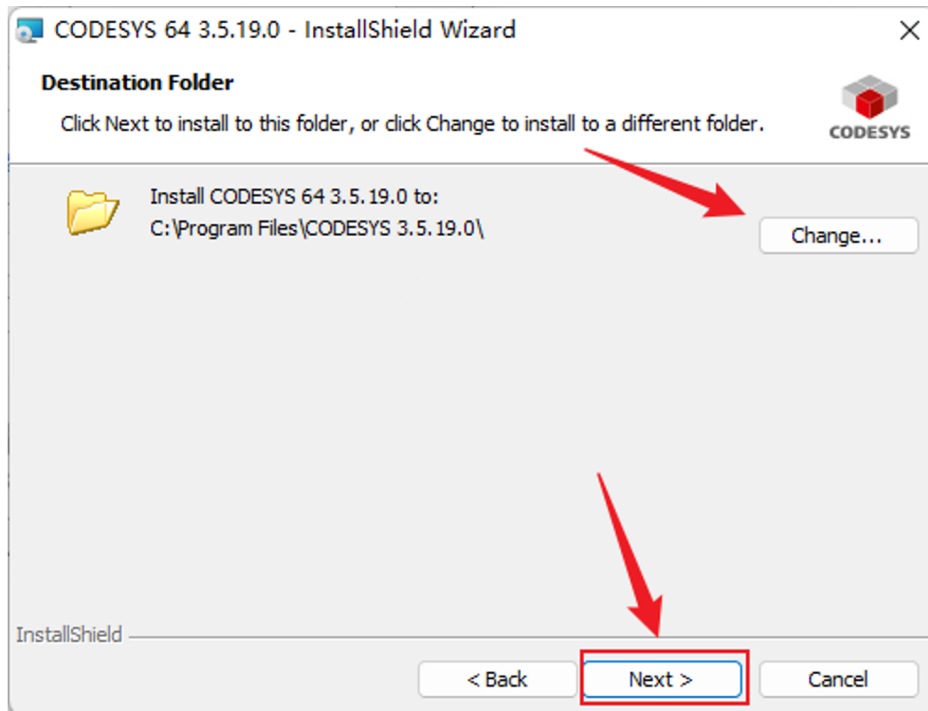

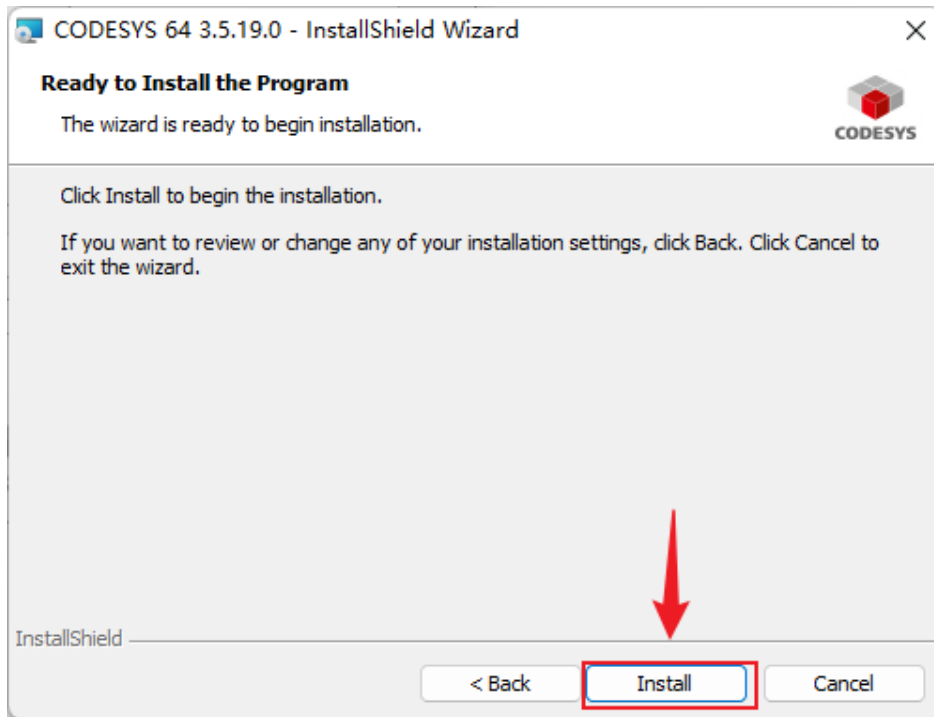

4.2 Use of Codesys software

Double-click the generated shortcut, run the Codesys programming software, and select "Tools – Device Repository" in the menu toolbar.

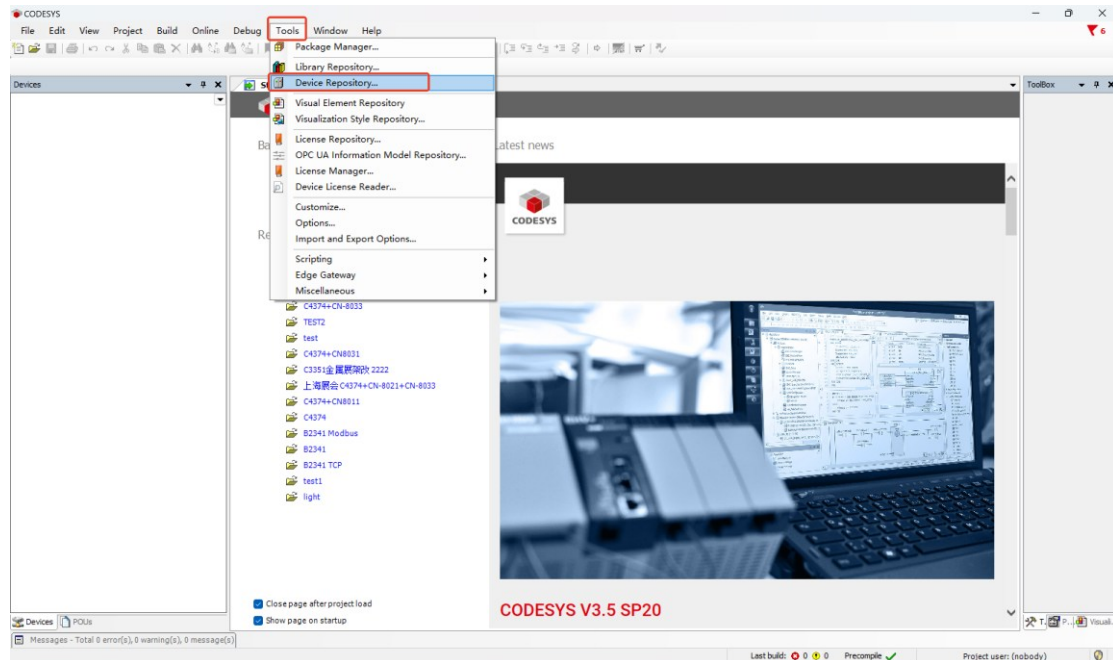

In the pop-up window, click Install, select the device description file of the C4374 (including the C4374 device and the IO module), and click Open.

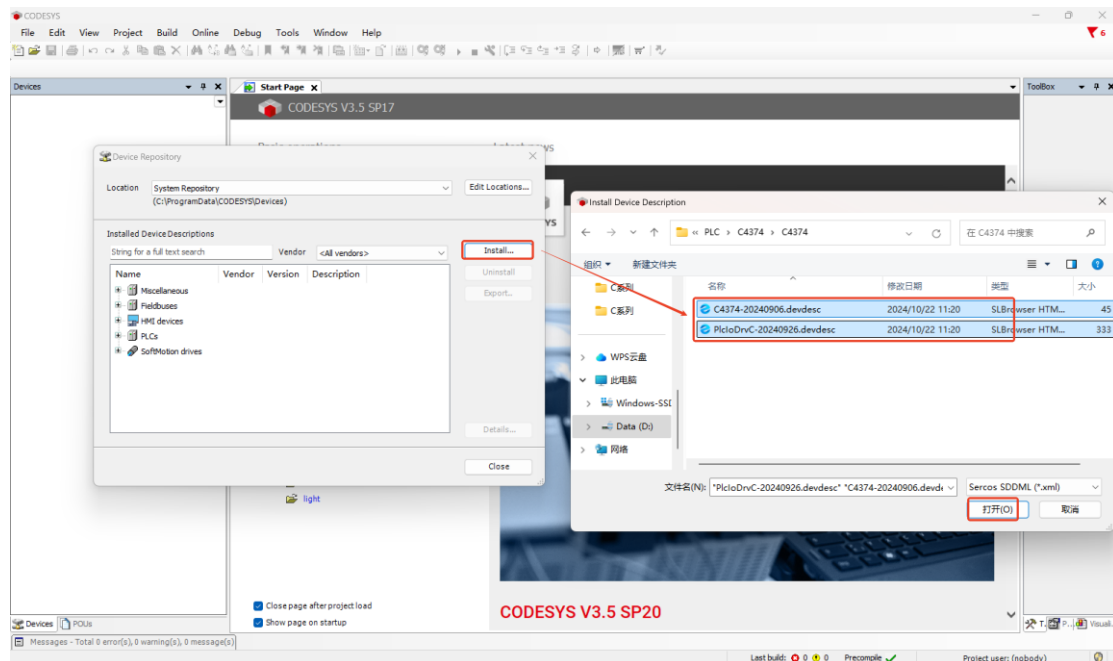

After the configuration is completed, close the device repository interface.

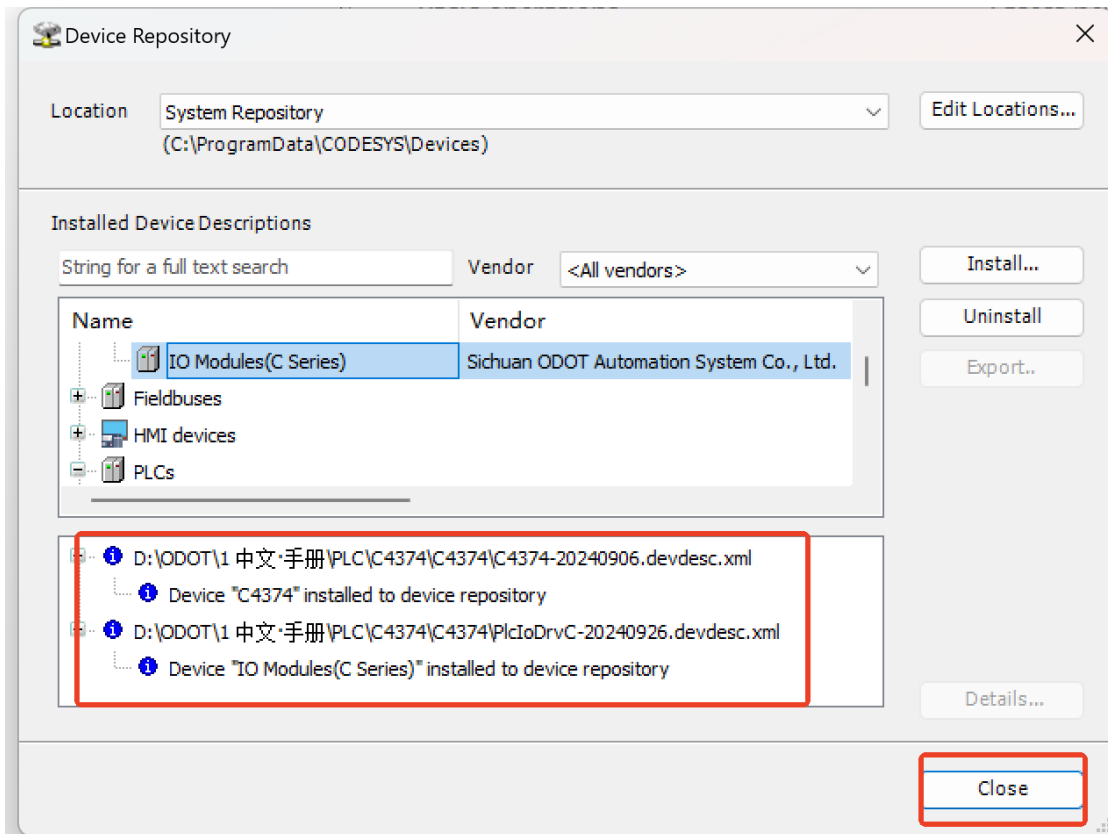

In the menu bar, select File - New Project, select the standard project in the pop-up window, set the project name and location, and click OK.

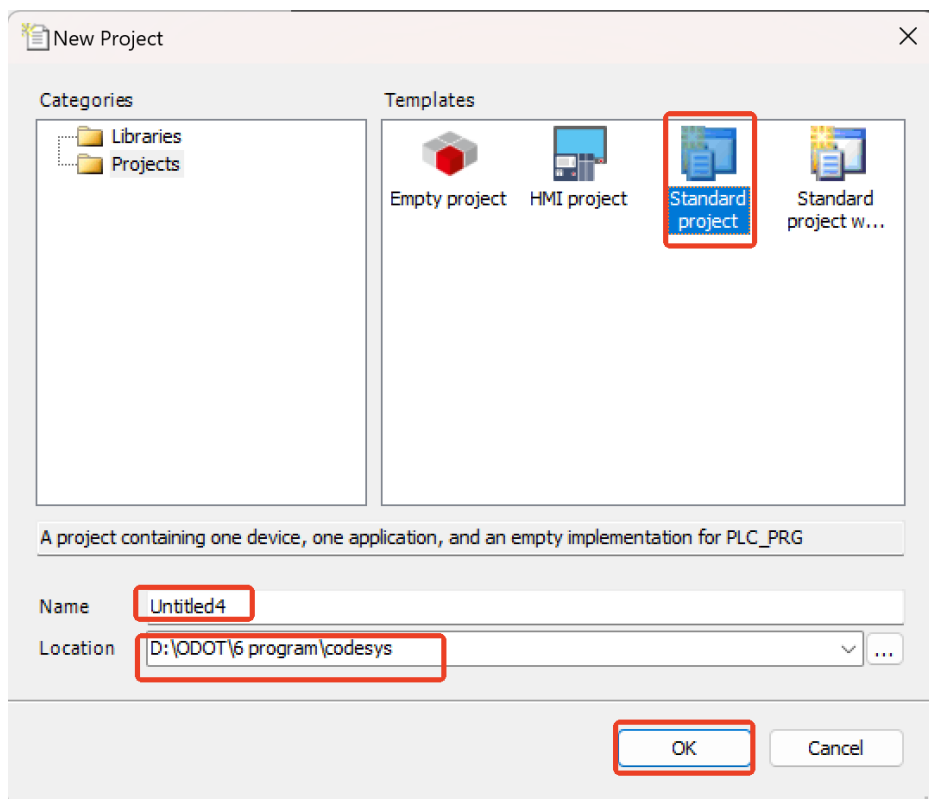

In the pop-up window, select C4374 as the device and click OK.

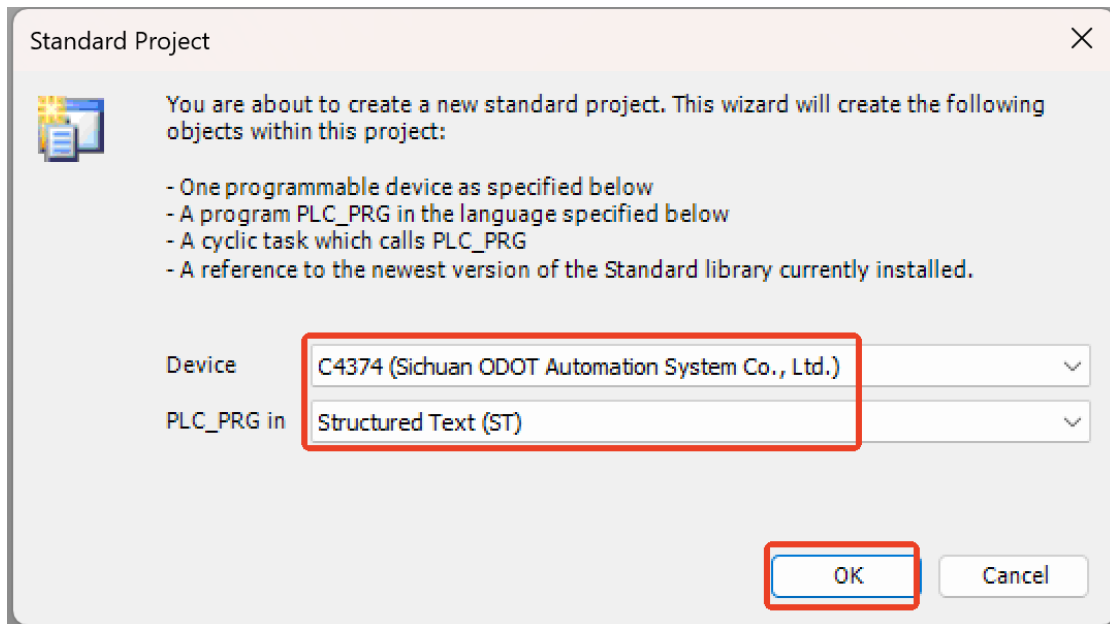

At this point, the project was established.

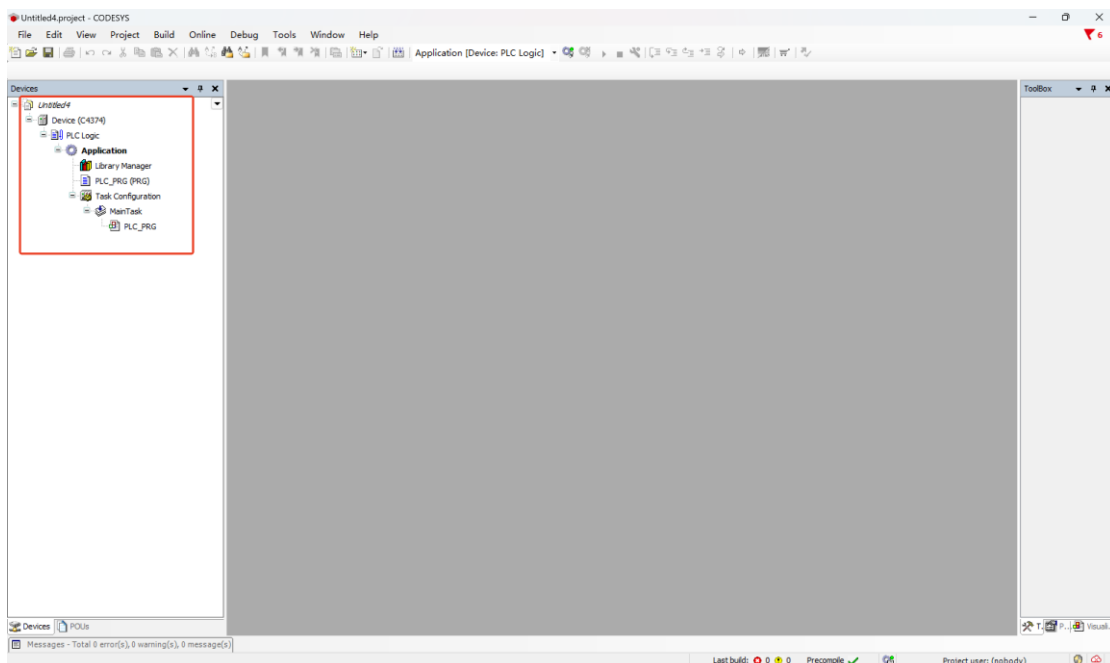

The first time install Codesys and create a project for compilation, which will find a lot of missing items, the solution is to open the library manager, click "Download Missing Libraries - Select All - Download", wait for the download to complete, and compile again.

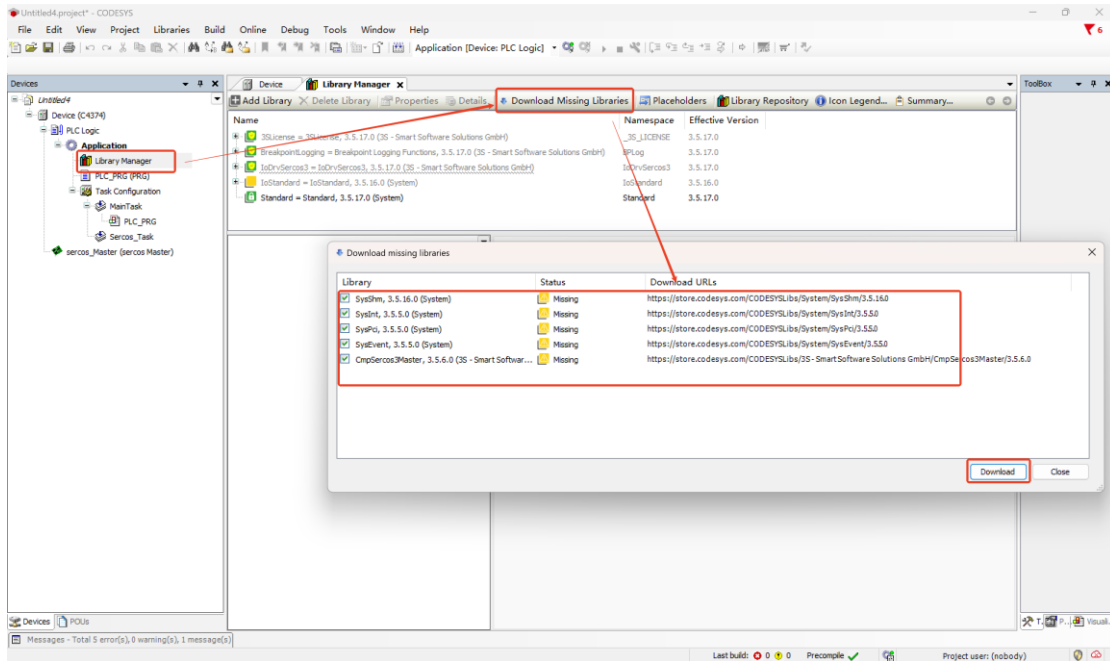

The introduction of the Codesys software interface is shown in the figure below, and the function introduction is detailed in the "PLC Comprehensive Development Tool - CODESYS Basic Programming and Application Guide".

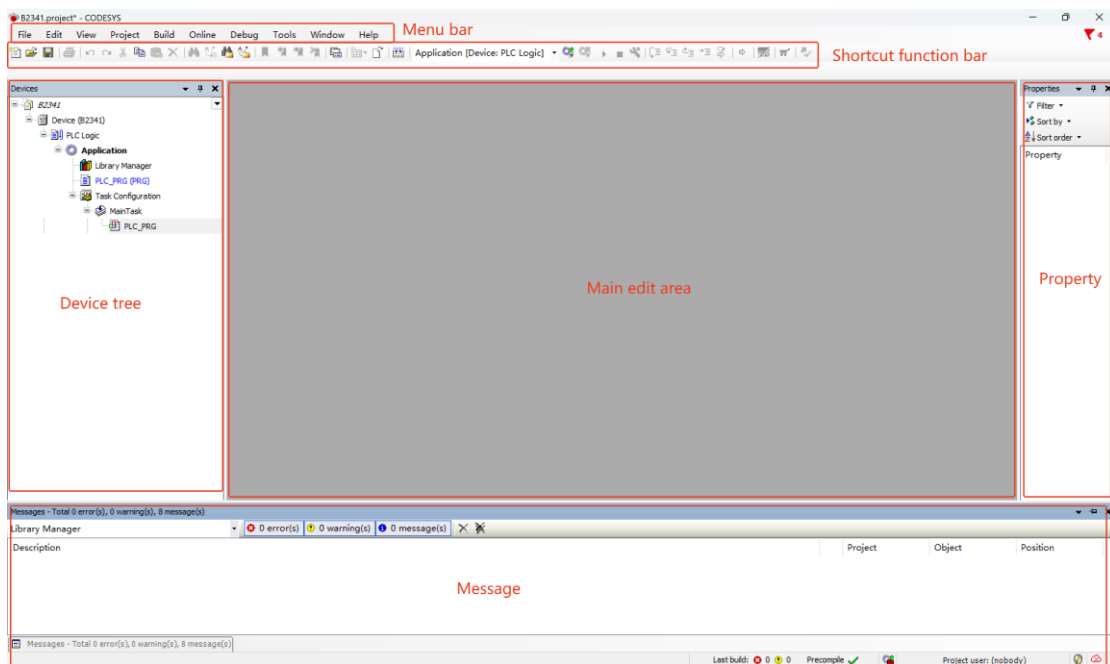

After the project is created, right-click C4374 and select Add Device.

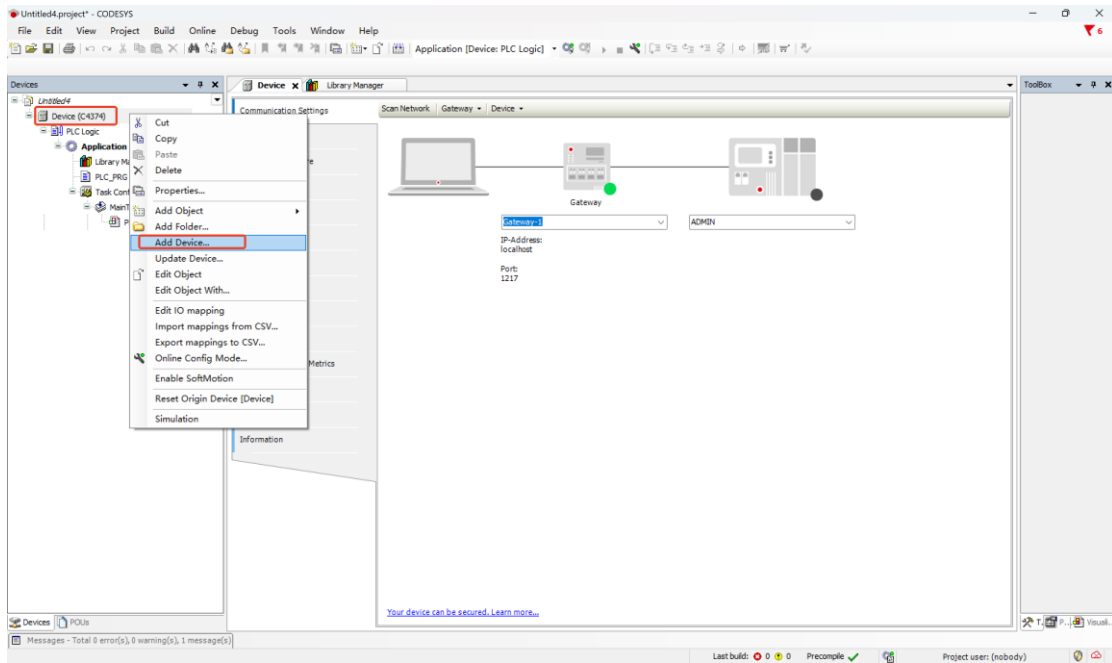

Find "IO Modules" in the pop-up window, select it, click Add Device, and don't need to close this page after adding.

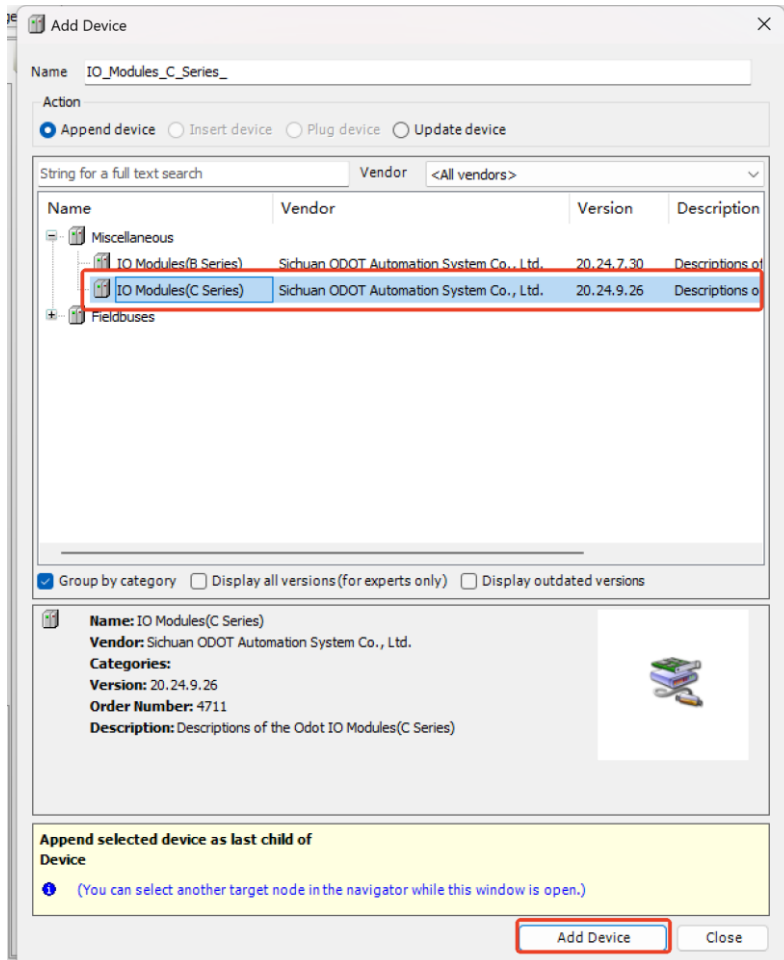

Select the "empty" slot, and insert the corresponding module according to the hardware configuration, and the functions of the module are listed in the selection table.

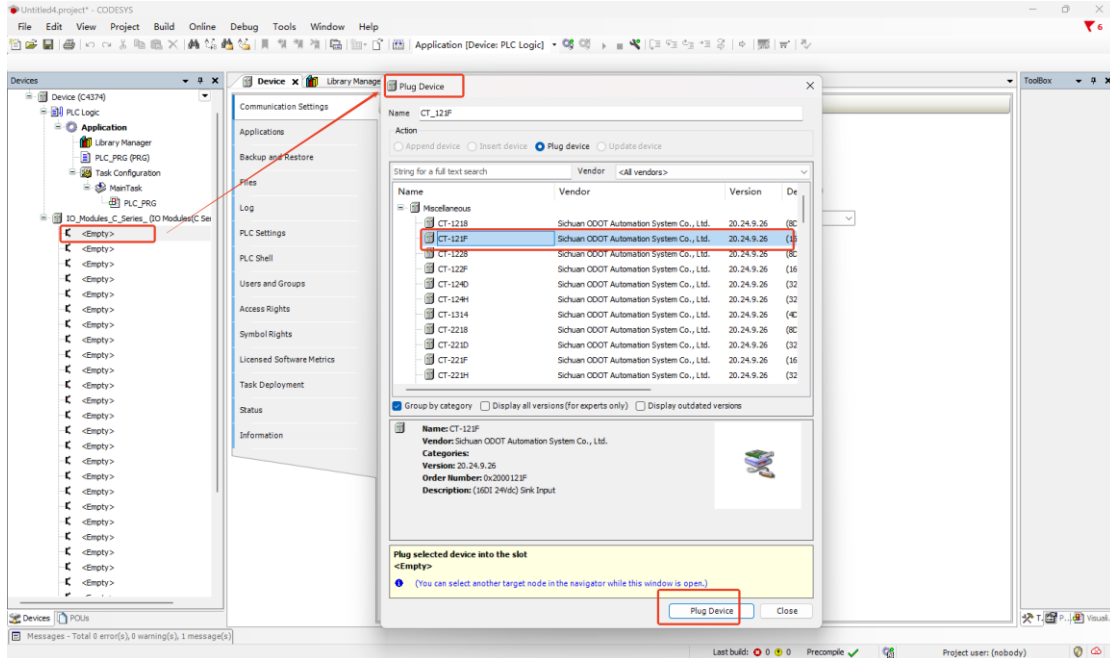

Double-click the module and select I/O Mapping to view the corresponding I/O address, set the mapping relationship, and set the Always Update variable to Enable 1.

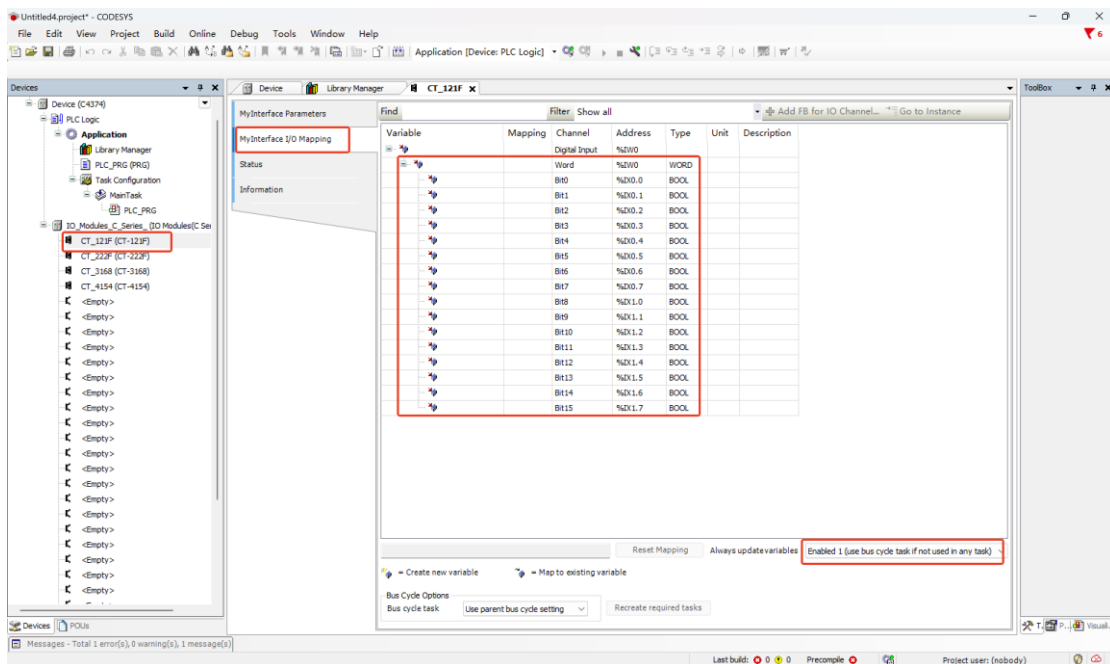

4.3 Download & Monitor

Double-click Device (C4374), select Communication Settings, enter the IP address of the C4374 module (the IP address of the module can be viewed through the LCD display), and press Enter to activate the device.

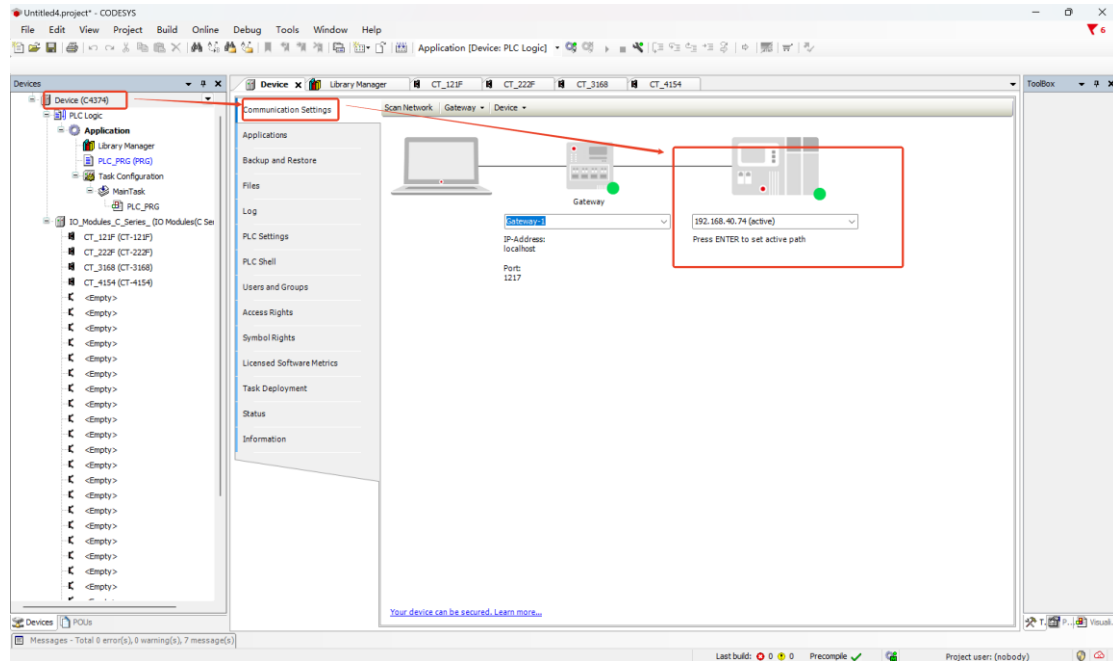

After the device is activated, compile, download, and run the program.

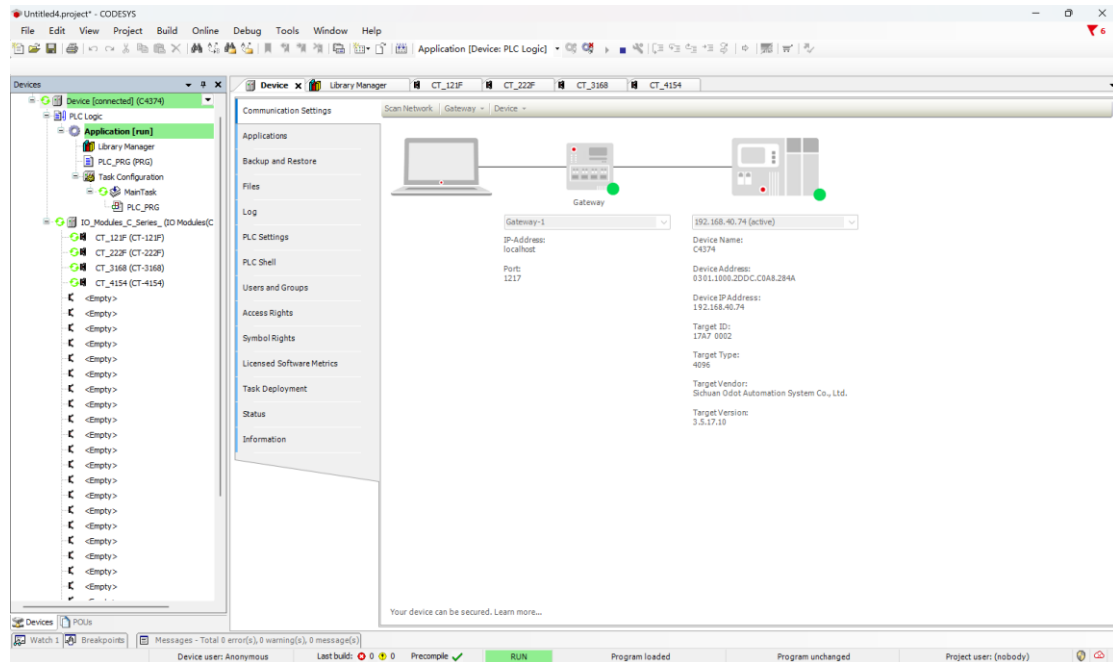

Select the module and click I/O Mapping to view the value of the corresponding module.

The screenshot displays the 'MyInterface Parameters' window for 'MyInterface I/O Mapping'. The 'Find' tab is active, showing a table of IO channels. The table columns are Variable, Mapping, Channel, Address, Type, Current Value, Prepared Value, Unit, and Description. A red box highlights the 'Current Value' column, which contains values like 21847, TRUE, and FALSE. The 'Channel' column lists addresses from %Q0.0 to %Q1.7. The 'Type' column lists WORD and BOOL. The 'Prepared Value' column is empty. The 'Unit' and 'Description' columns are also empty.

Variable	Mapping	Channel	Address	Type	Current Value	Prepared Value	Unit	Description
		Word	%Q0	WORD	21847			
		B0	%Q0.0	BOOL	TRUE			
		B1	%Q0.1	BOOL	TRUE			
		B2	%Q0.2	BOOL	TRUE			
		B3	%Q0.3	BOOL	FALSE			
		B4	%Q0.4	BOOL	TRUE			
		B5	%Q0.5	BOOL	FALSE			
		B6	%Q0.6	BOOL	TRUE			
		B7	%Q0.7	BOOL	FALSE			
		B8	%Q1.0	BOOL	TRUE			
		B9	%Q1.1	BOOL	FALSE			
		B10	%Q1.2	BOOL	TRUE			
		B11	%Q1.3	BOOL	FALSE			
		B12	%Q1.4	BOOL	TRUE			
		B13	%Q1.5	BOOL	FALSE			
		B14	%Q1.6	BOOL	TRUE			
		B15	%Q1.7	BOOL	FALSE			

At the bottom of the window, there are options for 'Create new variable' and 'Map to existing variable', and a 'Bus Cycle Options' section with a 'Bus cycle task' dropdown set to 'Use parent bus cycle setting' and a 'Recreate required tasks' button.

5 Example demonstration

5.1 Control demand

Project Name: Part of the process of sewage treatment plant (sump to regulating tank);

Project function: The external sewage is automatically replenished to the sump tank, and the water in the sump is sent to the regulating tank through the pumping pump for further sewage treatment.

Project requirements: The start and stop of the pump is jointly determined by the level switch of the regulating tank and the collecting basin, and a level gauge is installed in the collecting tank and the regulating basin respectively, which can detect the liquid level value of the pool. Sound and light alarms are installed in the collecting tank and the regulating tank to alarm the liquid level, and the yellow indicator light is on when the pump is faulty, and the green indicator light is on when it is running.

5.2 Preparation

Pump control conditions

Starting conditions: If the level of the regulating tank is low and the level of the sump is not low, start the pump.

Stop condition: Stop the pump when the level of the regulating tank is high or the level of the sump is low.

Alarm conditions: When the level of the sump is higher than 4.5 meters or the level of the regulating tank is higher than 3.5 meters, the audible and visual alarm will be triggered.

Point statistics

DI: 2 sets of liquid level switches with high level and low liquid level, and 6 DI signals for pump operation and fault signals

DO: Pump drive, 2 audible and visual alarms drive, 2 indicator lights for a total of 5 DO signals

AI: 2 sets of analog signals for level gauges, a total of 2 AI signals

Project Analysis:

Combined with the actual situation of the C4374 module, it is demonstrated, and according to the selection table: the CT-121F module is selected to connect the DI signal (high level signal) of the collection tank and the pump, the CT-222F module outputs the DO signal of the collection tank and the pump, and the CT-3168 is connected to the analog signal of the collection tank; The EtherCAT master function is used to receive the DI (CT-121F) and AI (CT-3234) signals of the conditioning cell and output the DO (CT-222F) signal.

5.3 Project Establishment

In the menu bar, select File - New Project, select the standard project in the pop-up window, set the project name and location, and click OK.

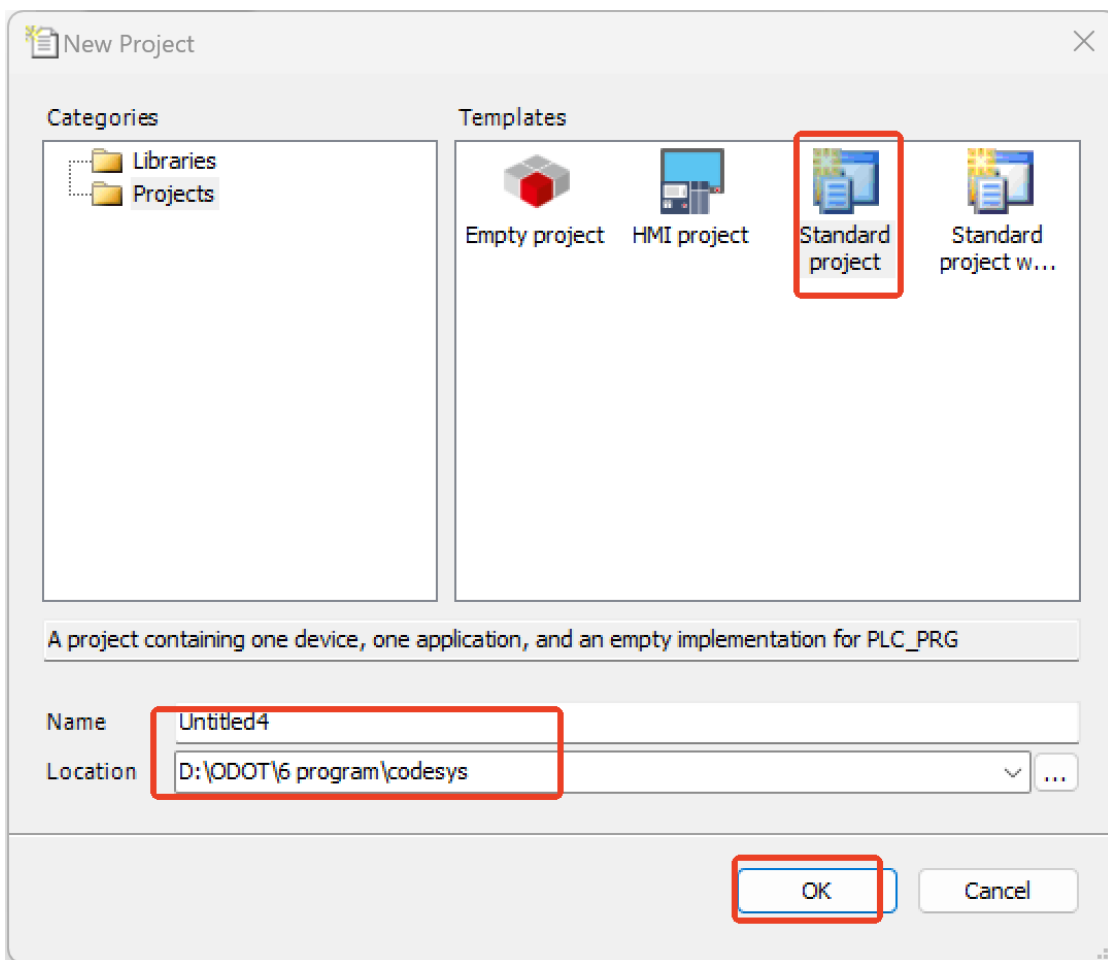

In the pop-up window, select C4374 as the device and click OK.

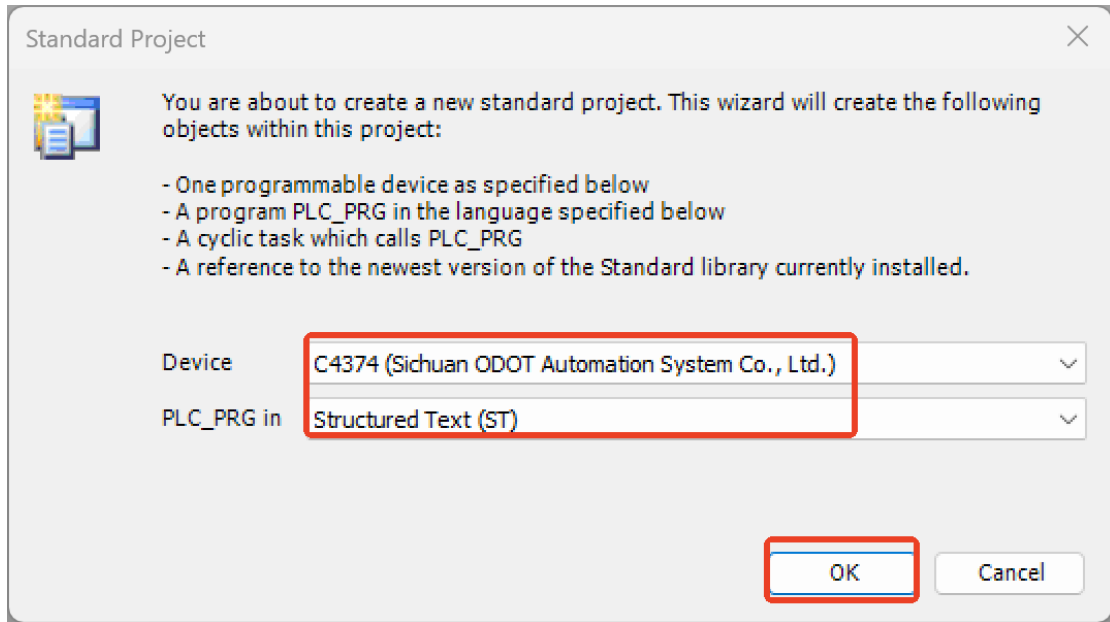

After the project is created, right-click C4374 and select Add Device. Find "IO Modules" in the pop-up window, select it, click Add Device, and don't need to close this page after adding.

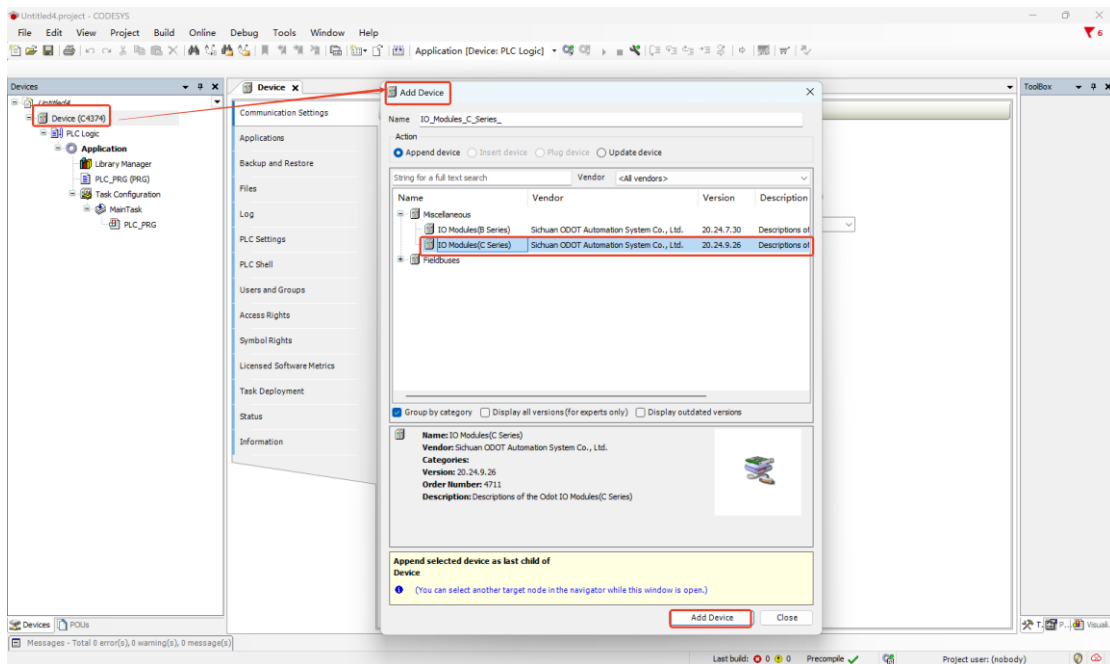

Select an empty slot and insert the corresponding CT-121F, CT-222F, and CT-3168 modules based on the hardware configuration.

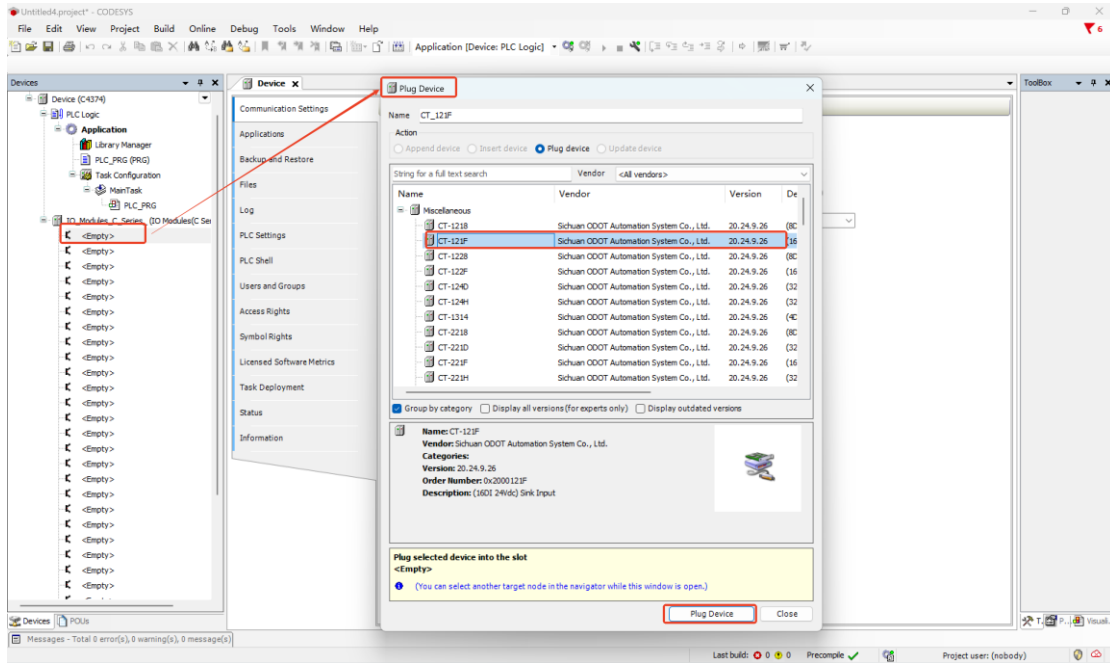

Double-click the module and select I/O Mapping to view the corresponding I/O address, set the mapping relationship, and set the Always Update variable to Enable 1.

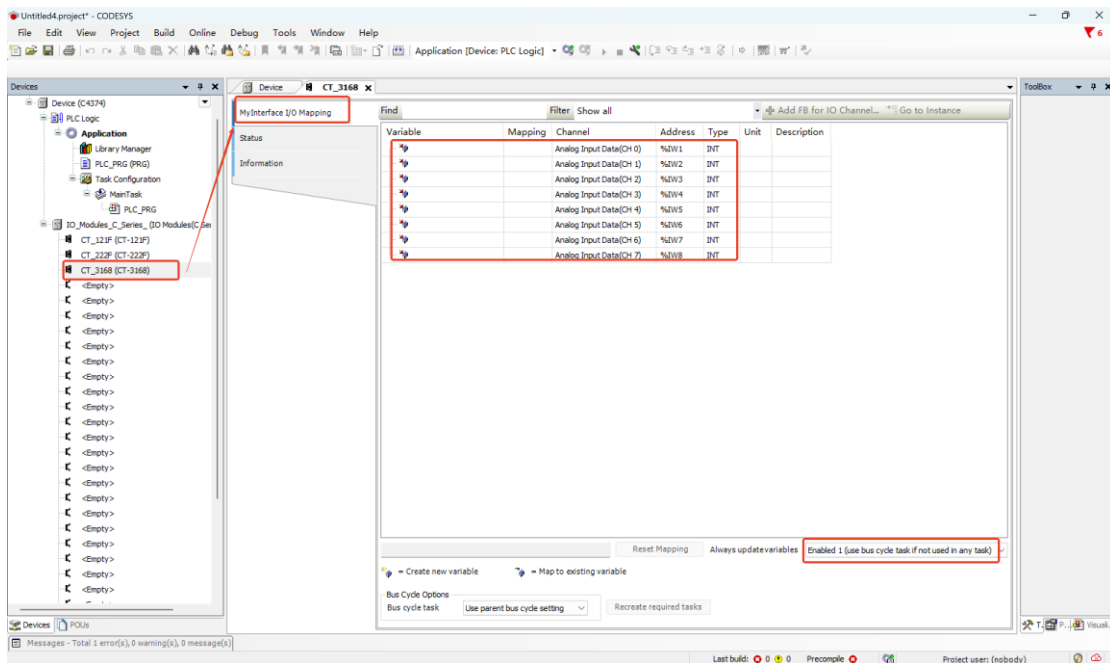

Right-click on C4374, select Add Device, select EtherCAT - Master - EtherCAT Master, and click Add Device.

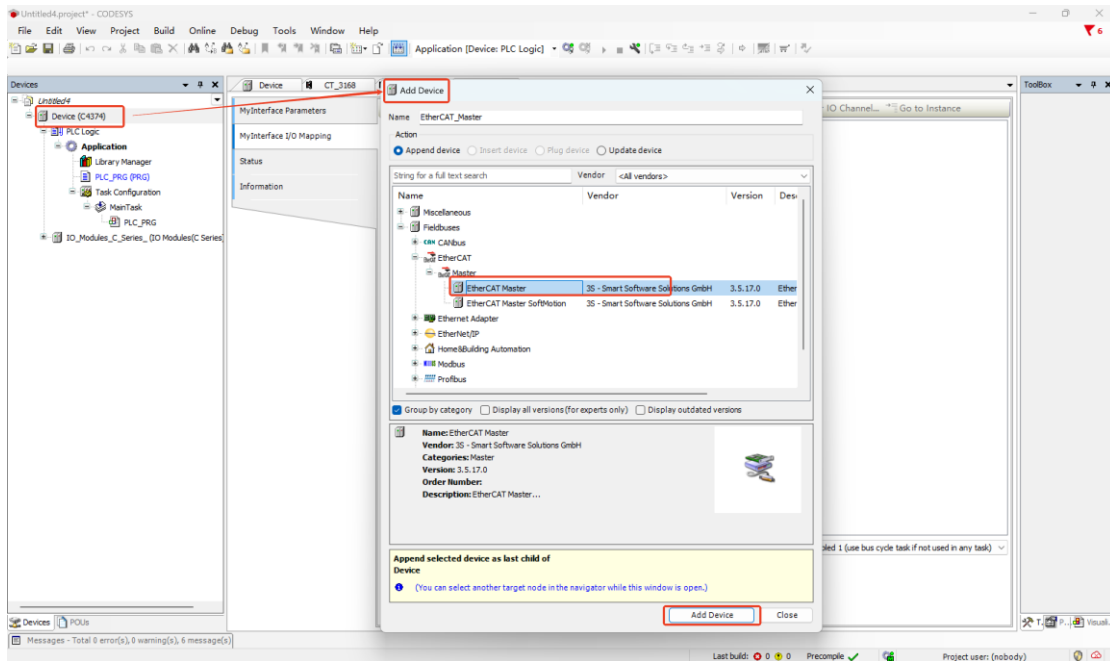

Double-click Device (C4374), select Communication Settings, enter the IP address of the C4374 module (the IP address of the module can be viewed on the LCD screen), and press Enter to activate the device.

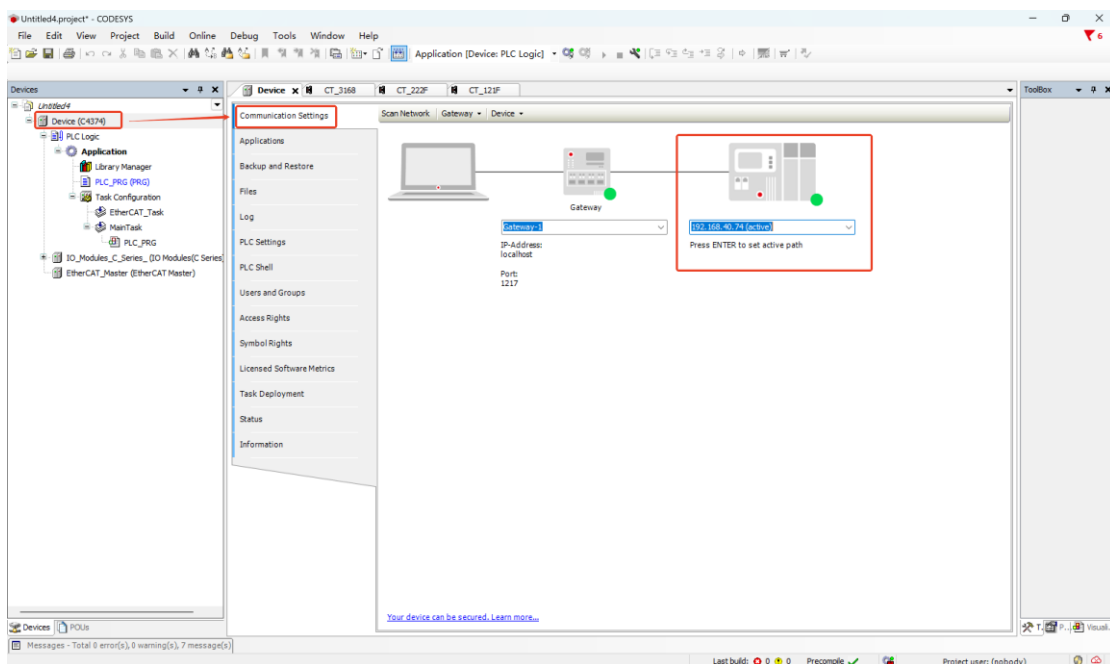

Double-click EtherCAT Master, select General, and in EtherCAT NIC settings, click Browse, select the corresponding network adapter, and click OK.

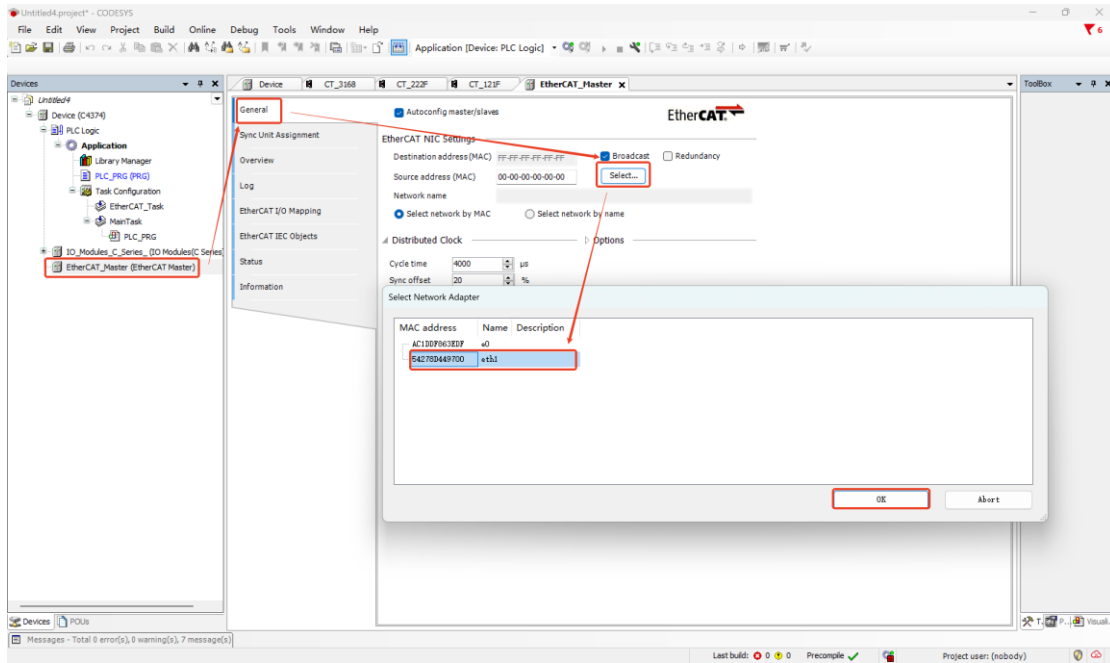

Right-click on the EtherCAT Master, click on the scan module, and the pop-up window will display "Scan device not available: stack unavailable!" Please log in first"

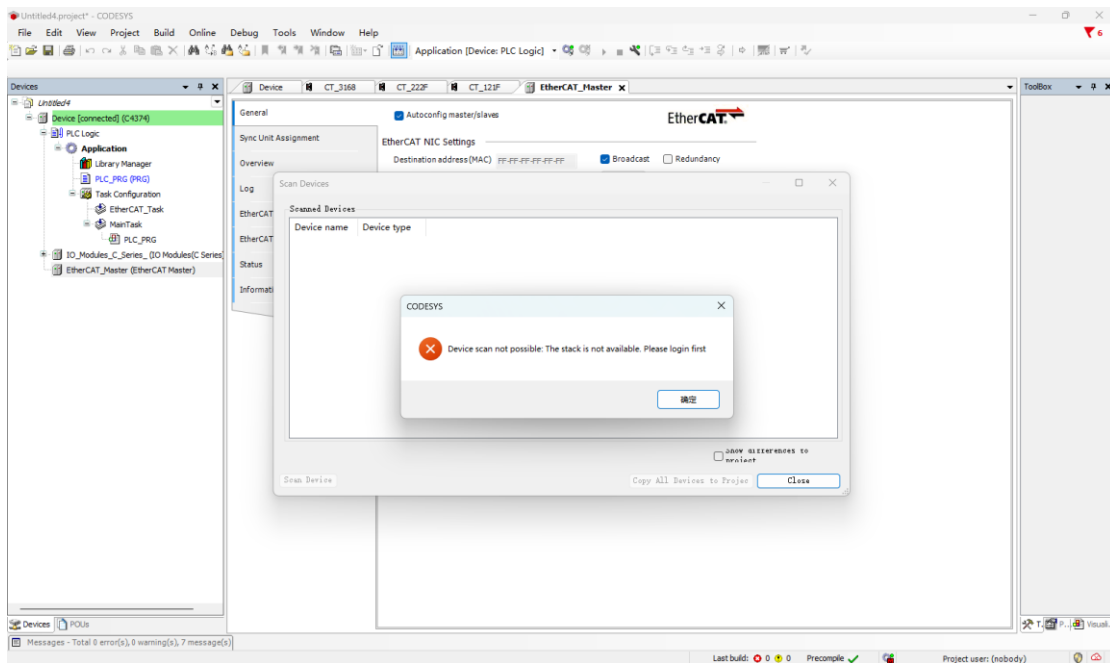

Close the window, select the PLC Device, click "Compile", compile without error, click "Login to", click Yes, and then click "Start".

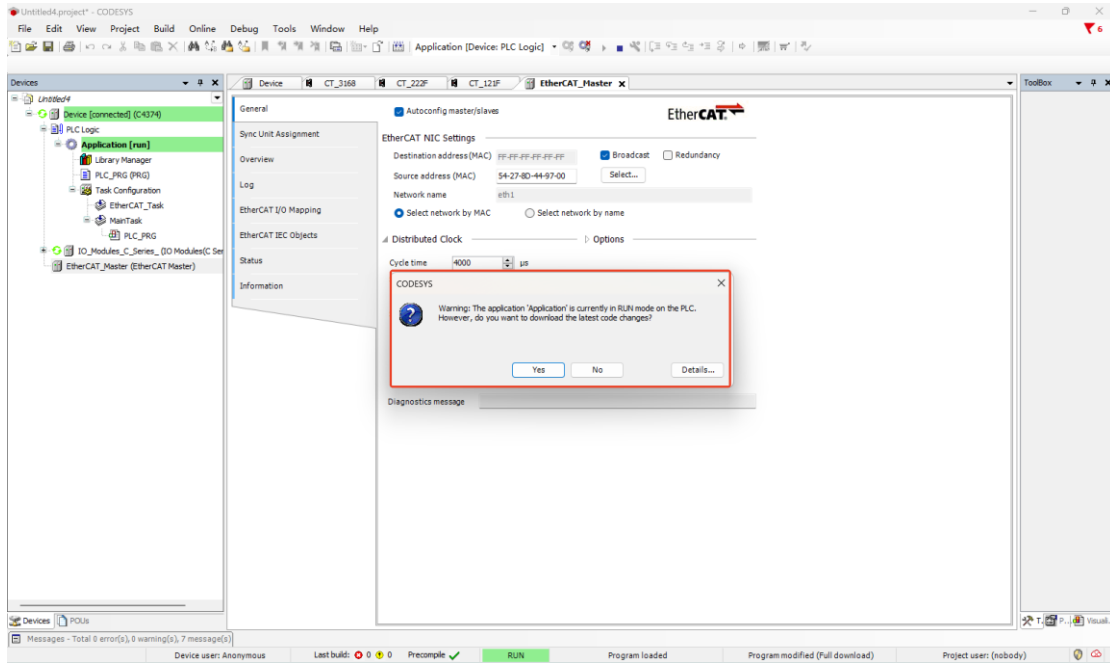

Right-click EtherCAT Master, click Scan Devices, it can view the IO modules mounted on CN-8033 and its back, and click Copy All Devices to the project.

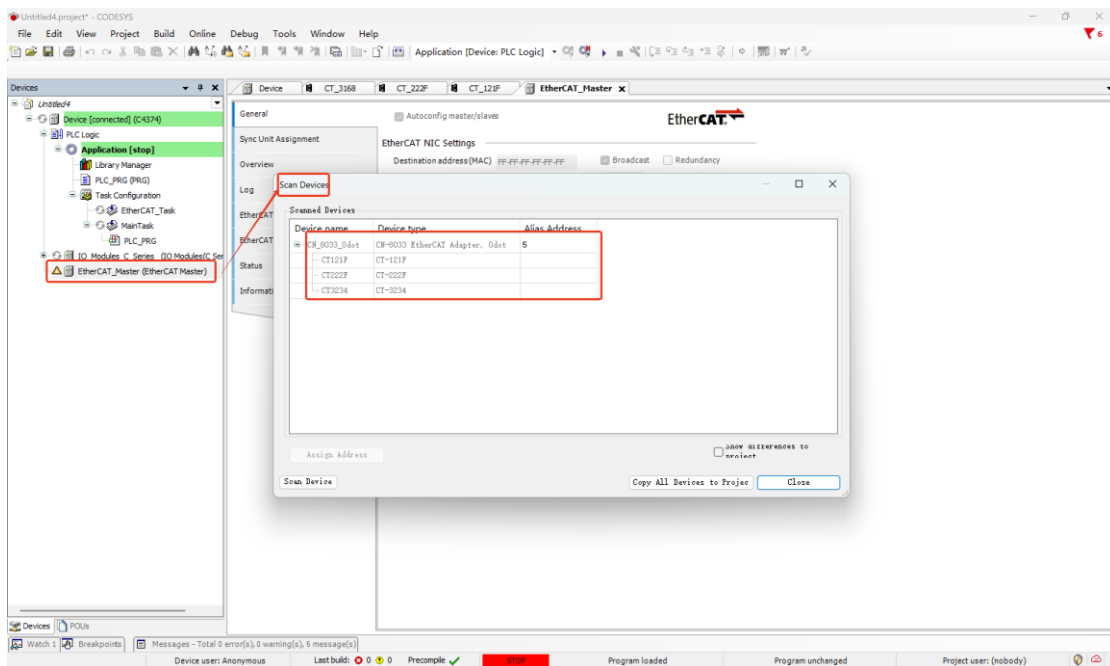

If the pop-up window shows that the device is not located in the device library, click Tools - Install Device Repository to install the device description file of CN-8033.

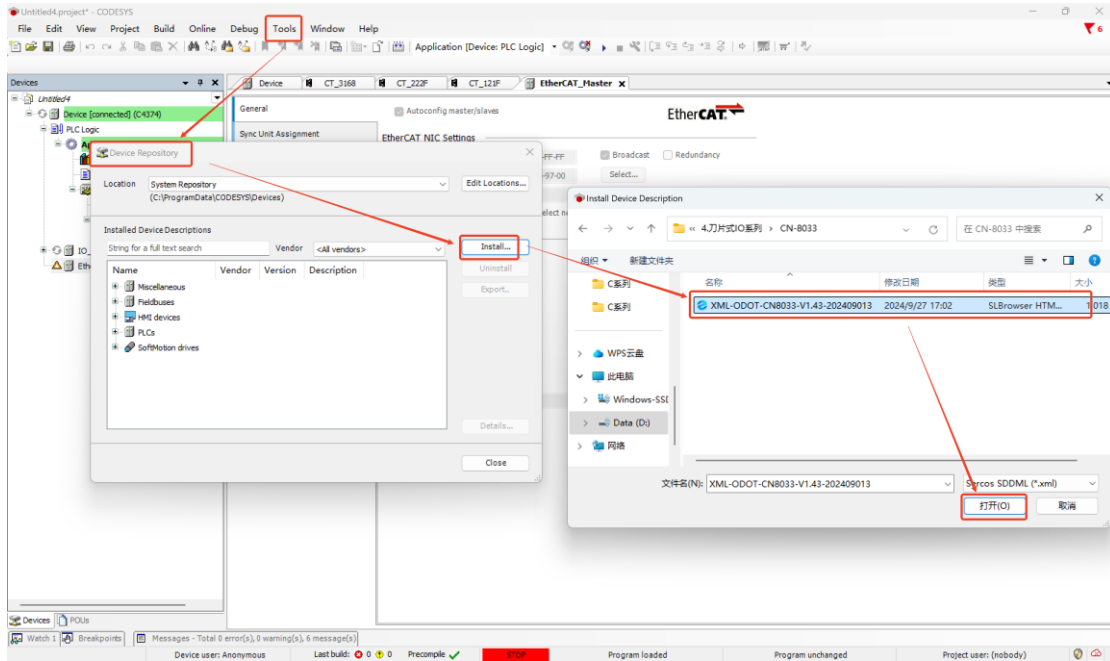

Log out of the PLC and select I/O Module --Module I/O Mapping to modify the address mapping relationship and set the Always Update variable to enable 1.

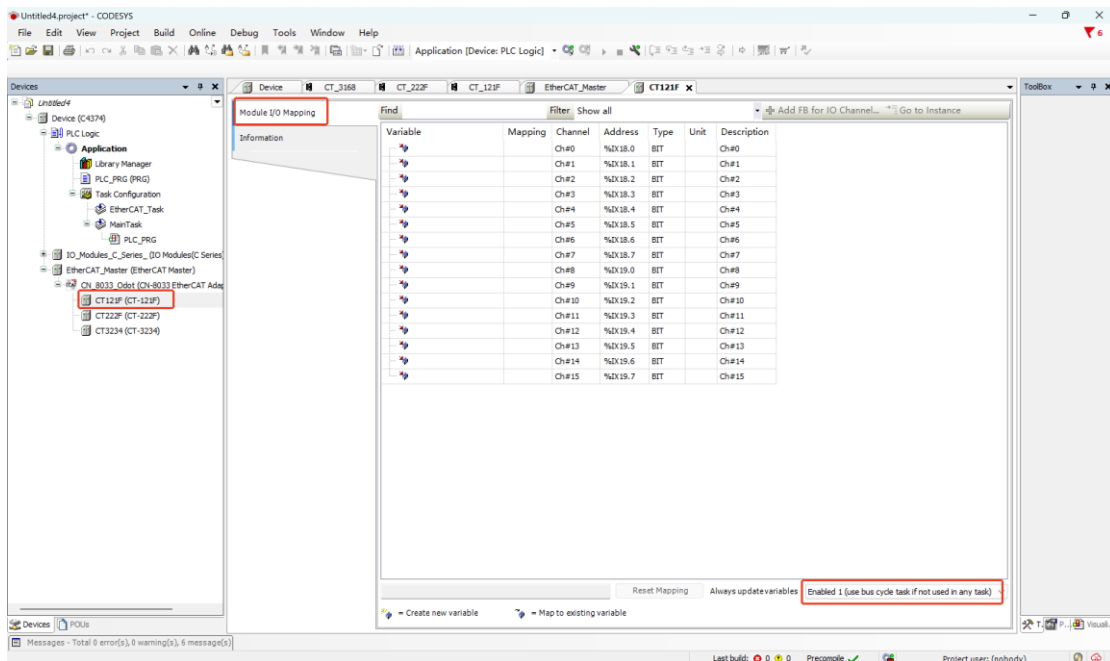

Considering the user's usage habits, FB blocks are often called in the process of program writing, and this time the analog input is used to build the block and the ST language is used to write.

Right-click Application, select "Add Object--POU", set the name of the function block, select the type as "Function block", select "Structured Text (ST)" as the

language, and click Add after the setting is complete.

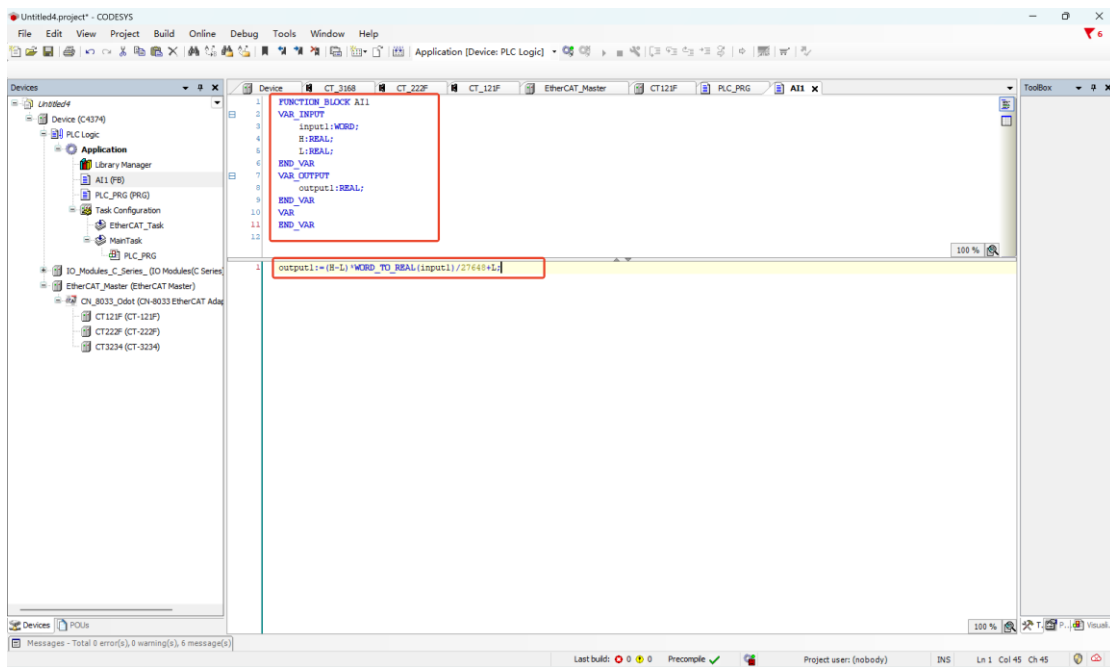
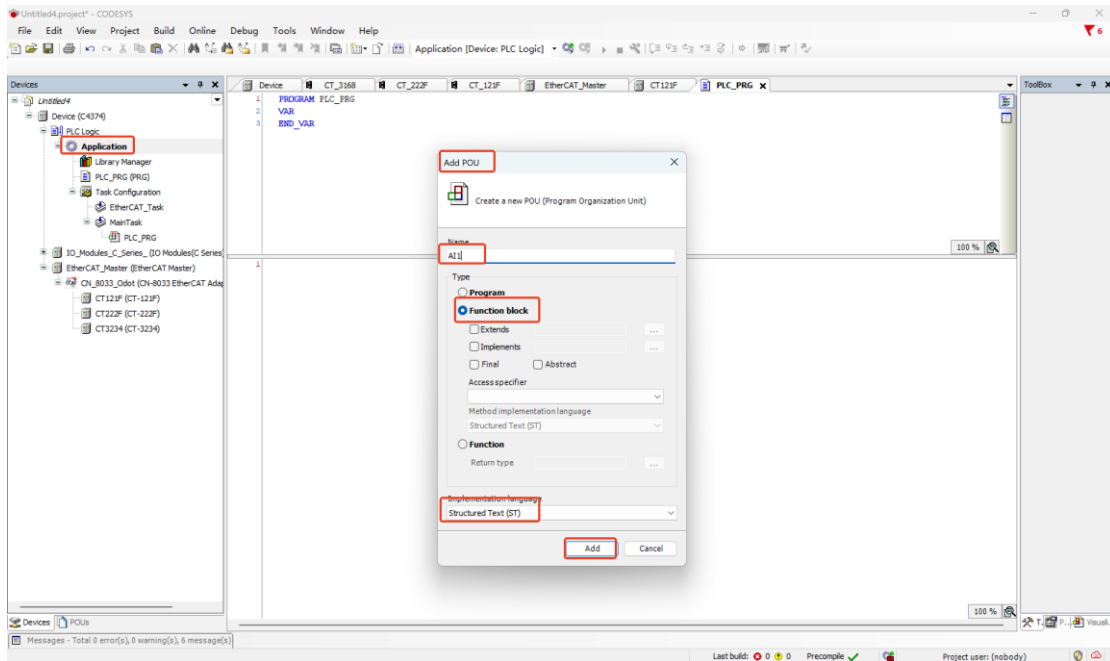

Next, the main program is written according to the control requirements.

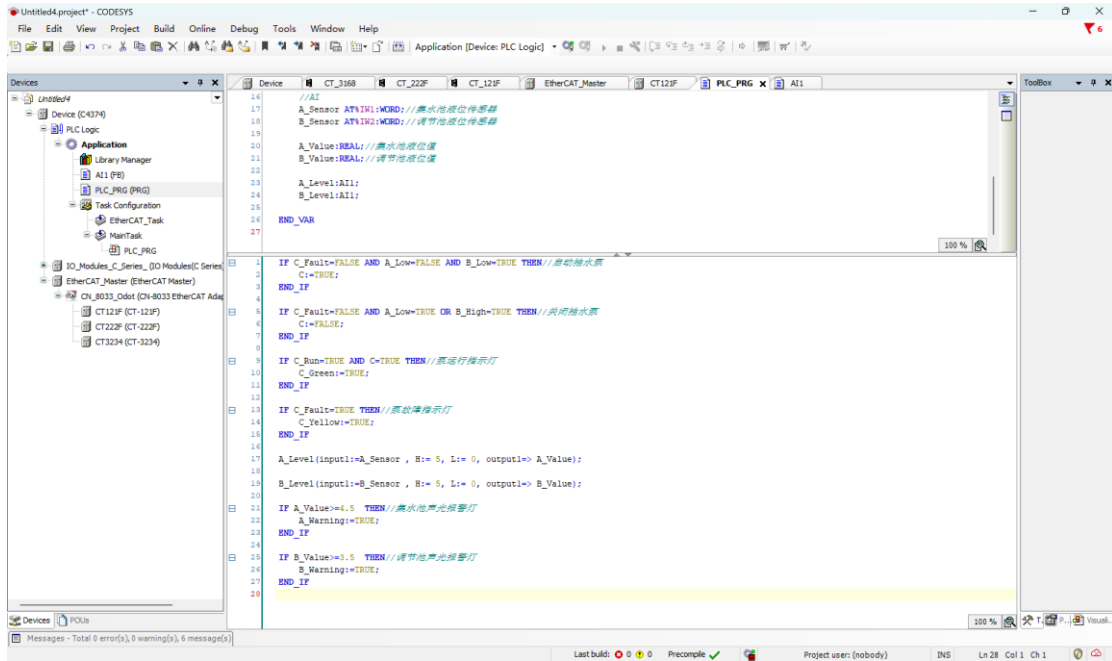

5.4 Program download and monitoring

Once the program is compiled, downloaded, and run, it can be monitored online.

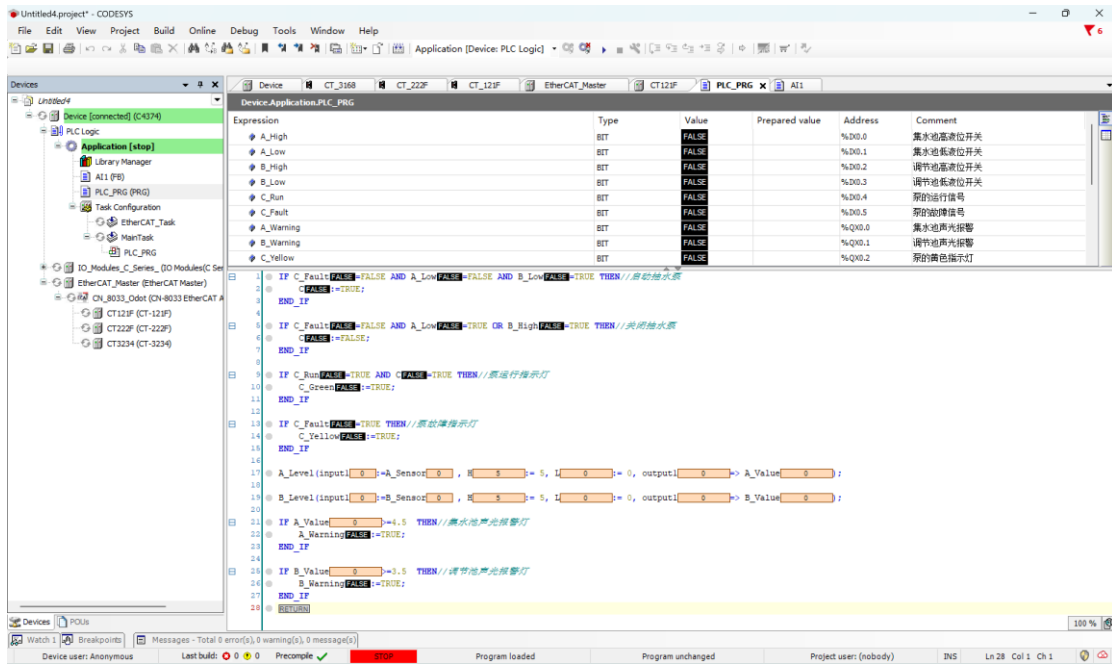

6 Example of communication

6.1 Modbus TCP Client

Topology diagram

Modbus TCP Client Communication topology diagram

Note: The red part of the figure is the communication topology of the case

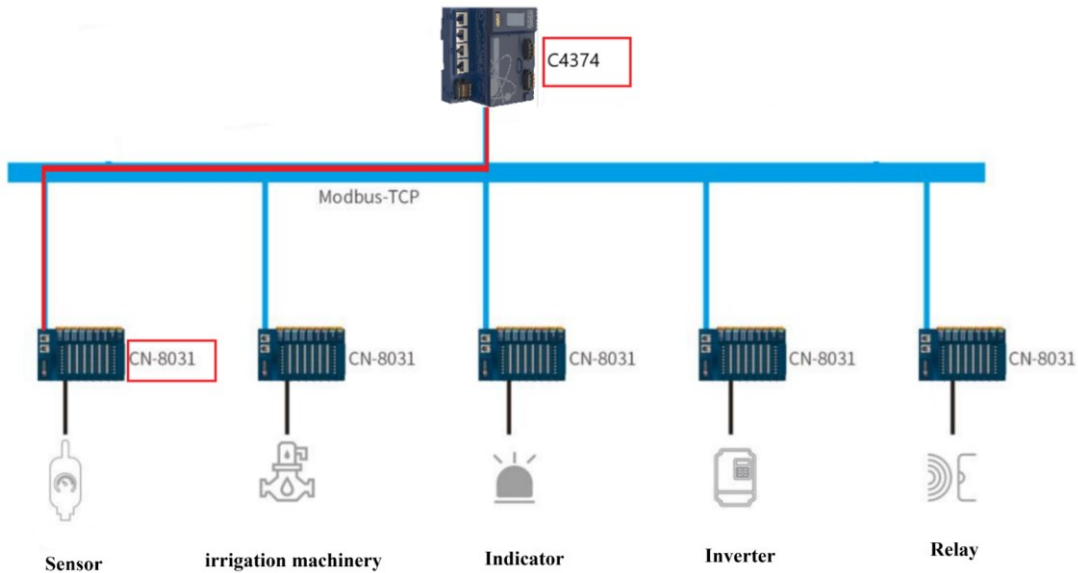

Hardware configuration: C4374+CT-121F+CT-222F+CT-3168+CT-4154+CT-5801;
 CN-8031+CT-121F+CT-222F+CT-3234+CT-4238;

First, open the Codesys software and click New Project.

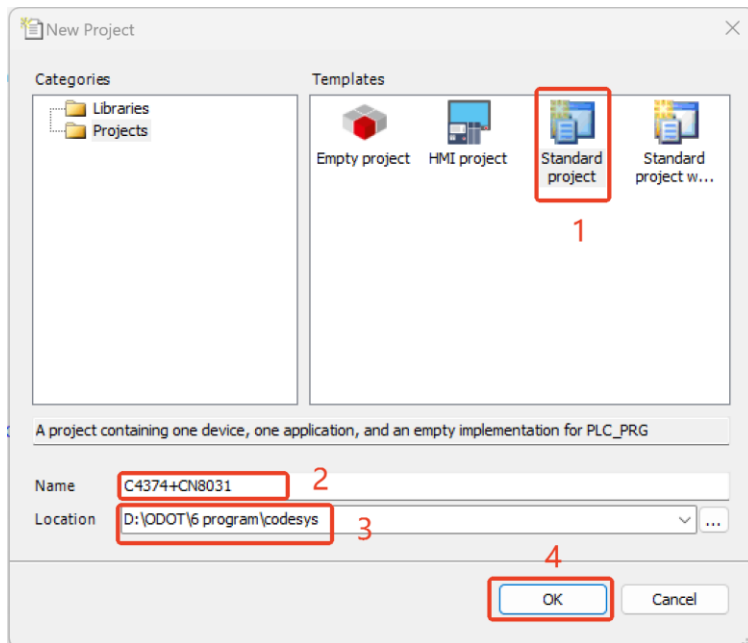

Then select the C4374 device, if can't find the device, refer to the installation device

description file, and click OK.

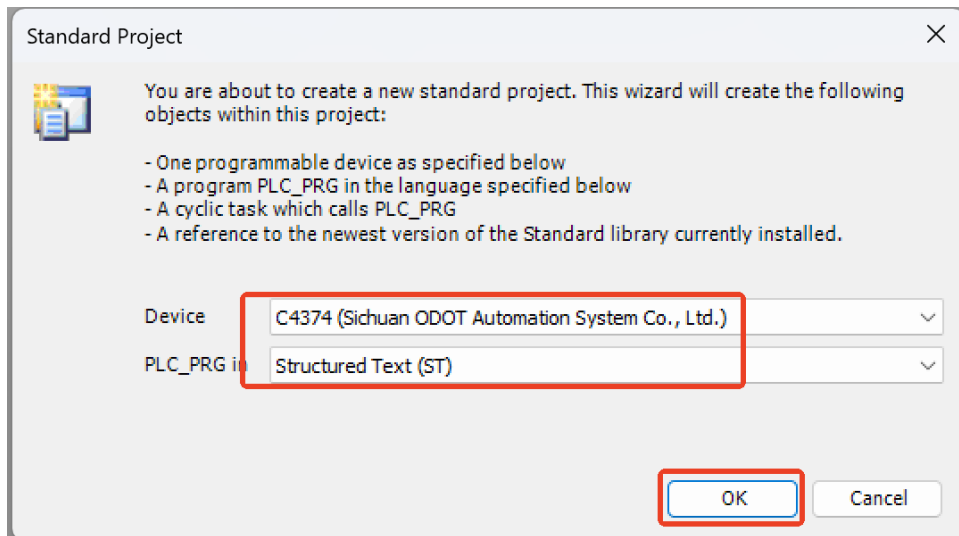

After the project is created, right-click C4374 and select Add Device.

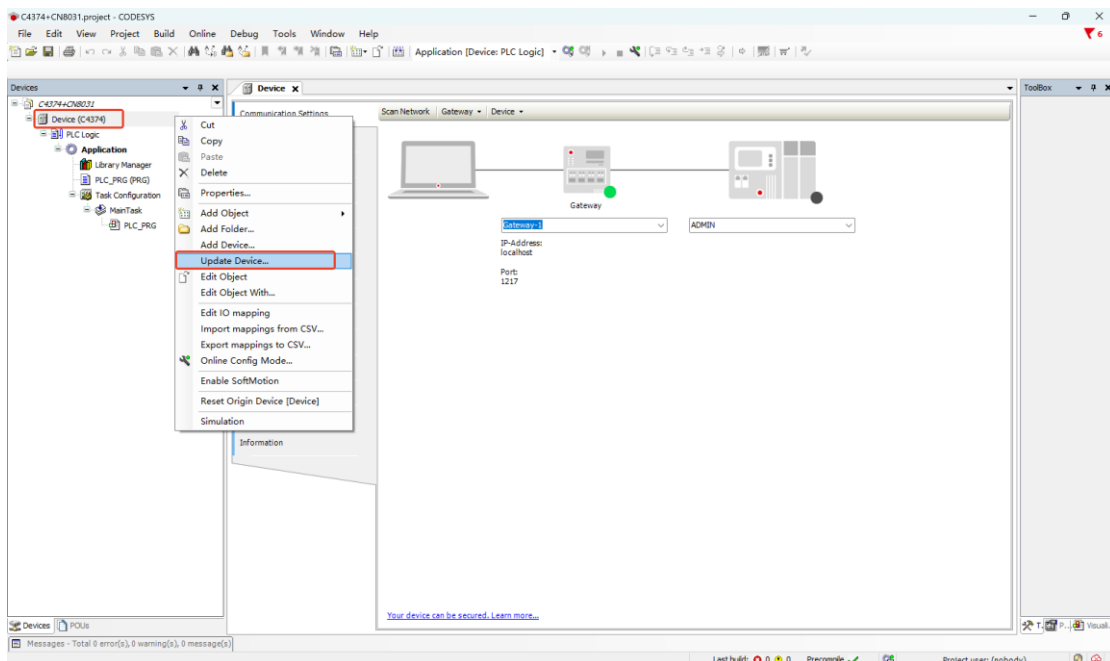

Find "IO Modules" in the pop-up window, select it, click Add Device, and don't need to close this page after adding.

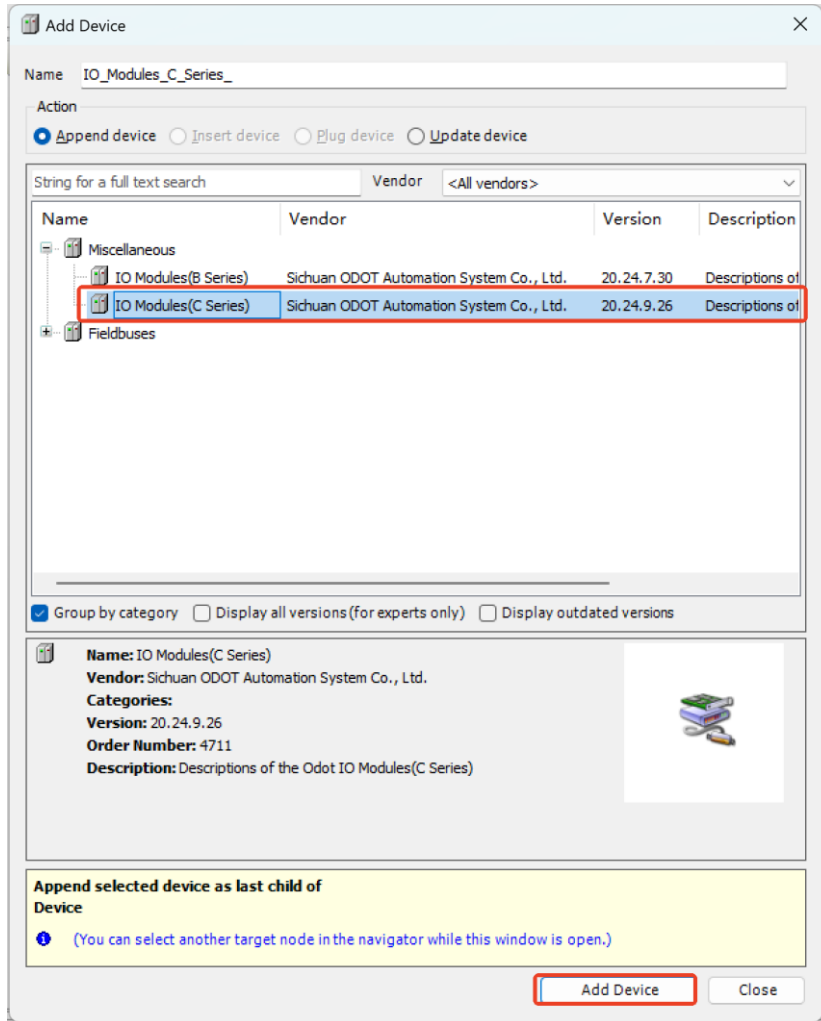

Select the "empty" slot, and insert the corresponding module according to the hardware configuration, and the functions of the module are listed in the selection table.

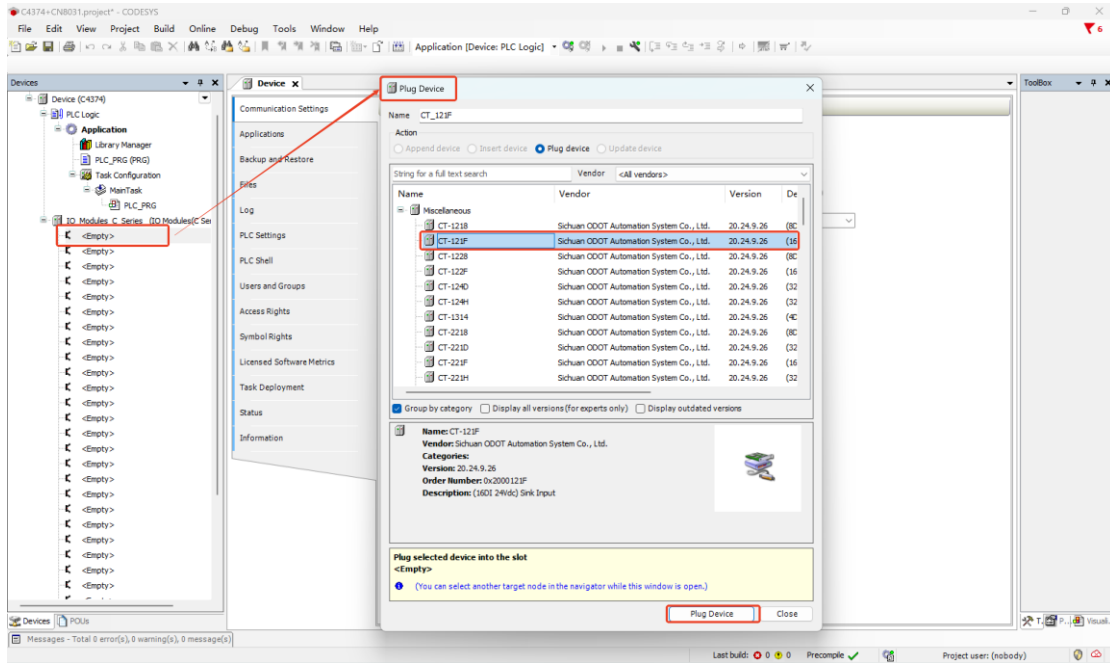

Double-click the module and select I/O Mapping to view the corresponding I/O address, set the mapping relationship, and set the Always Update variable to Enable 1.

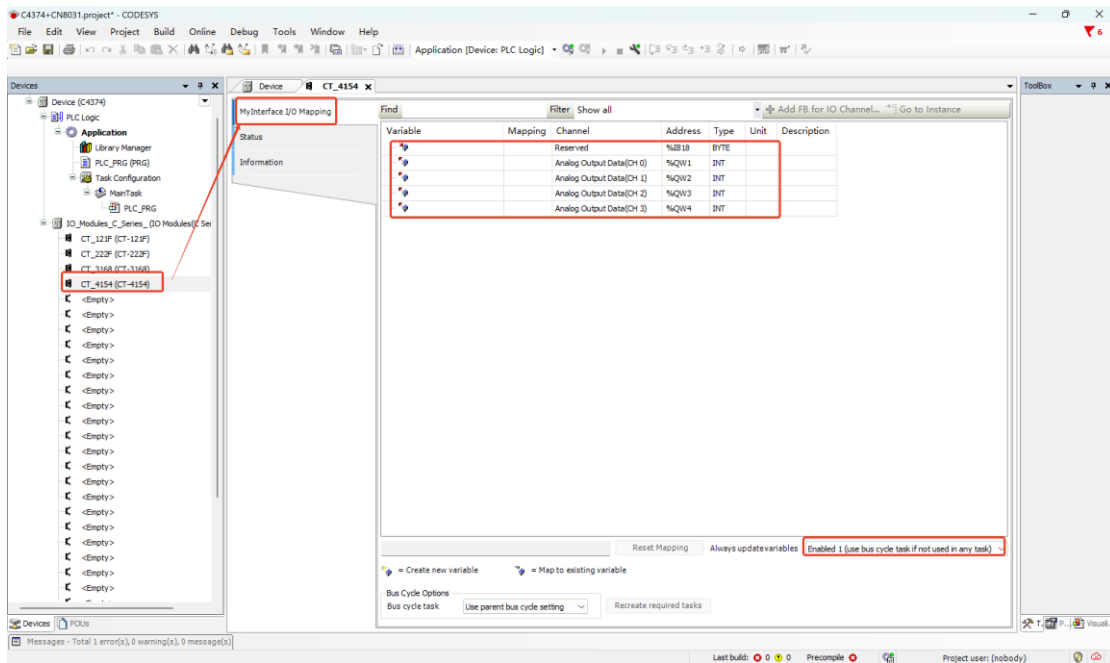

Right-click on C4374, select Add Device, select Ethernet Adapter, and click Add Device.

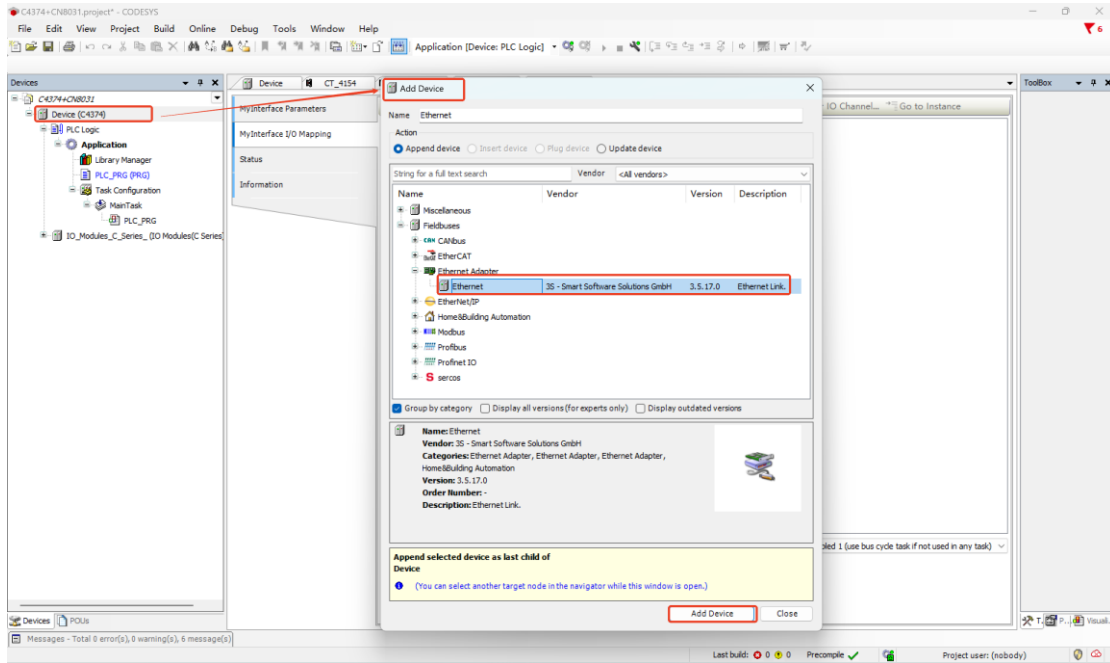

Right-click Ethernet, select Add Device, select Modbus TCP Master, and click Add Device.

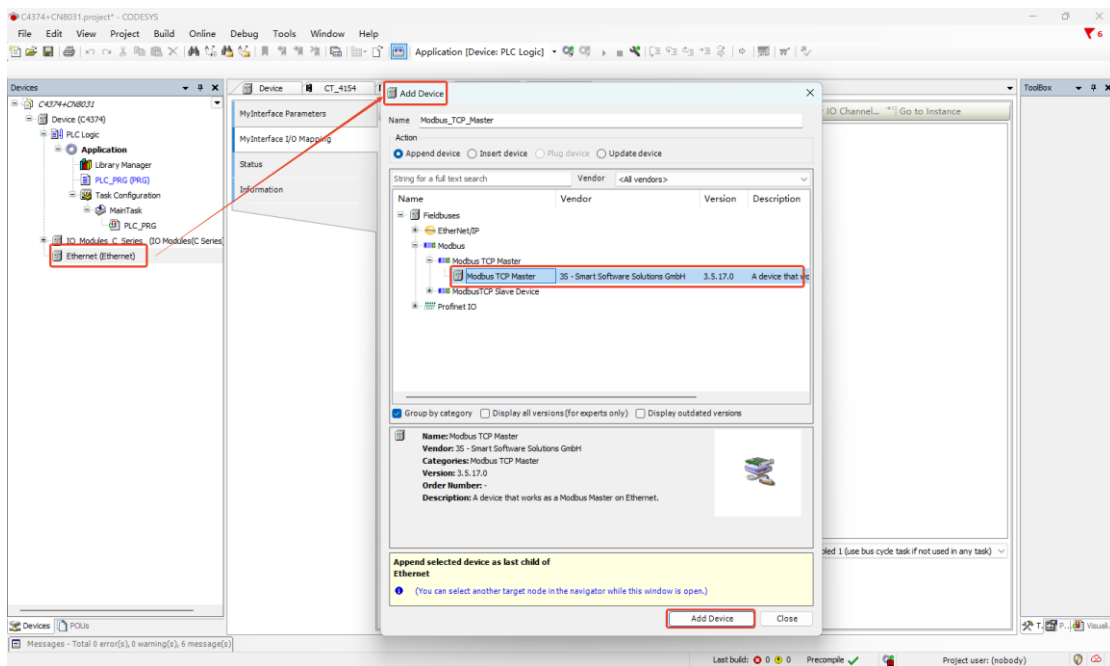

Right click Modbus TCP Master, select Add device, select “Modbus TCP Slave—Modbus TCP Slave”, click Add device.

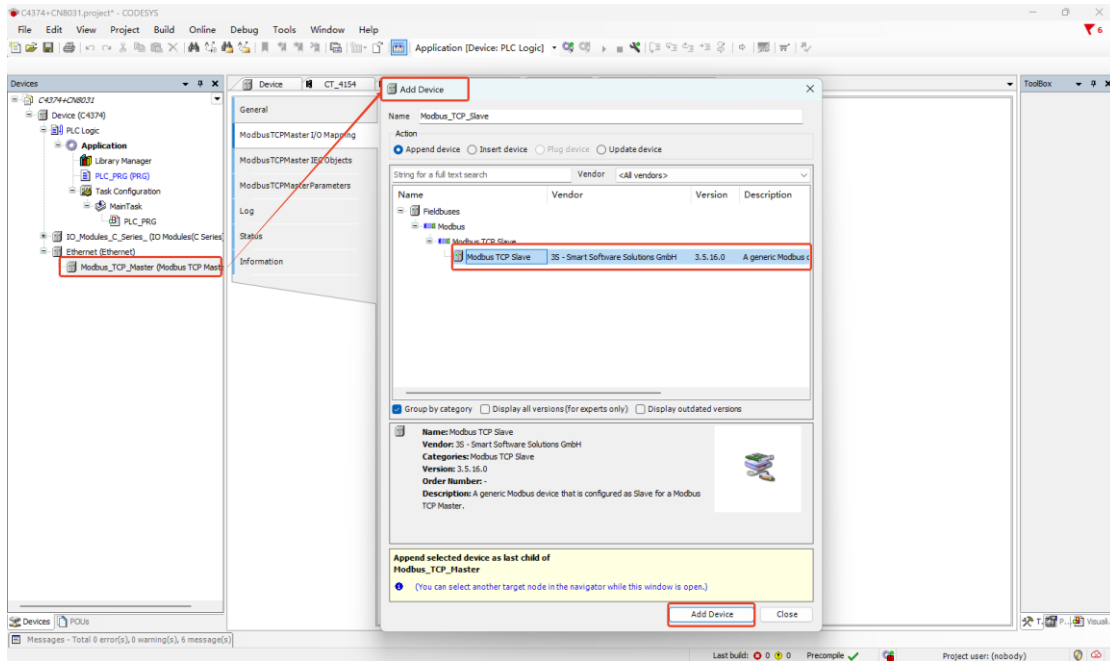

Double-click Device (C4374), select Communication Settings, enter the IP address of the C4374 module (the IP address of the module can be viewed through the LCD display), and press Enter to activate the device.

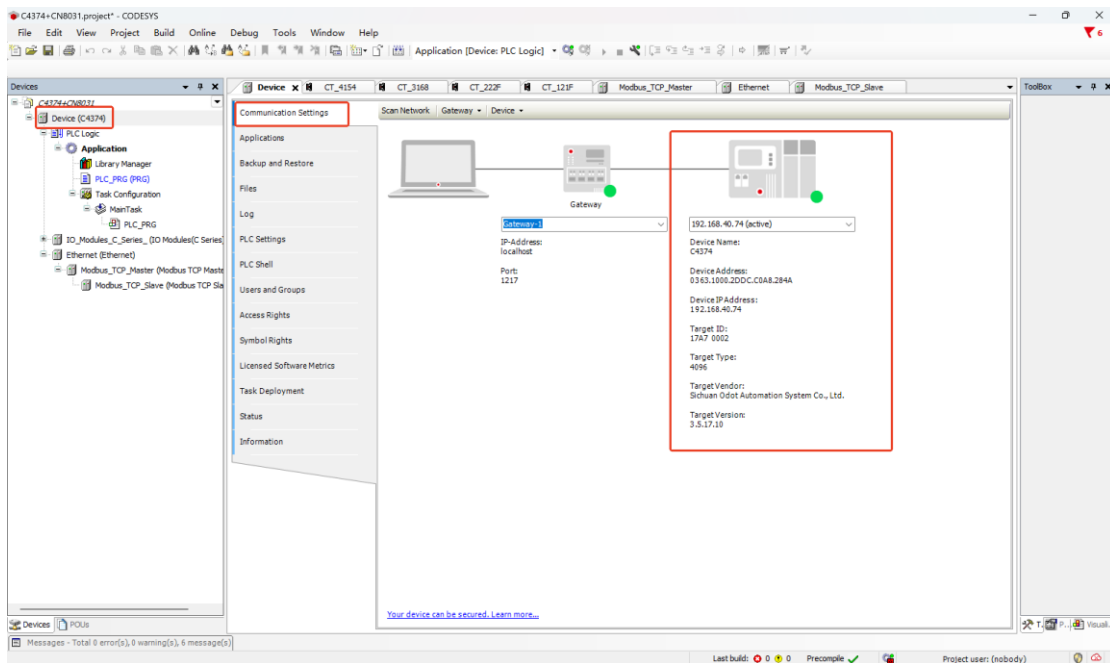

Double-click Ethernet, select General, click "Browse" at the network interface, select the corresponding network adapter, and click OK.

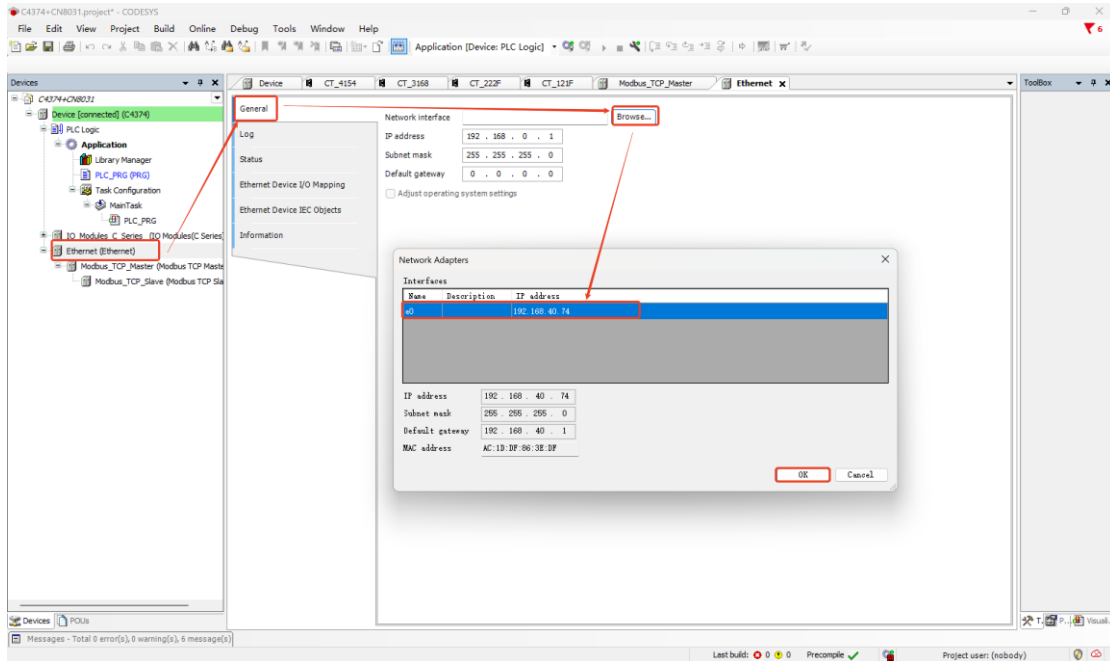

Double-click the Modbus TCP Master and select General to set the Modbus TCP response timeout TCP period and socket timeout period, and it is recommended to select the automatic reconnection function.

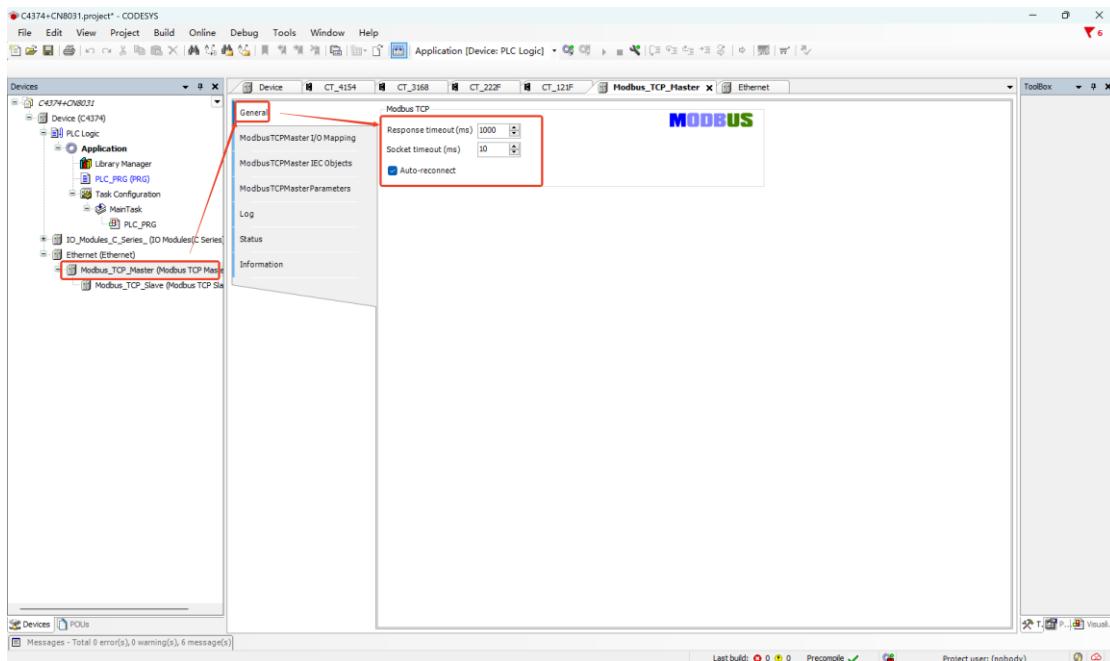

Double-click the Modbus TCP Slave and select General, the IP address of the slave CN-8031 module is 192.168.40.100, the response time and the port number.

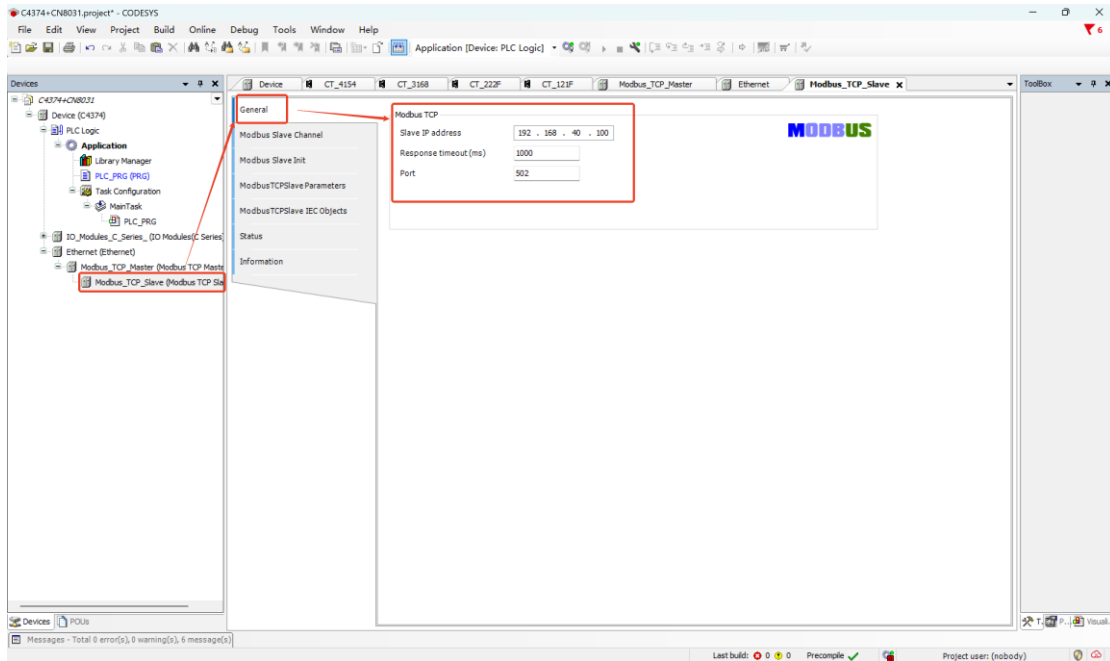

The parameters of the slave CN-8031 module can be viewed in IO Config software. Select CN-8031 and click the address table to view the address mapping of the I/O modules mounted.

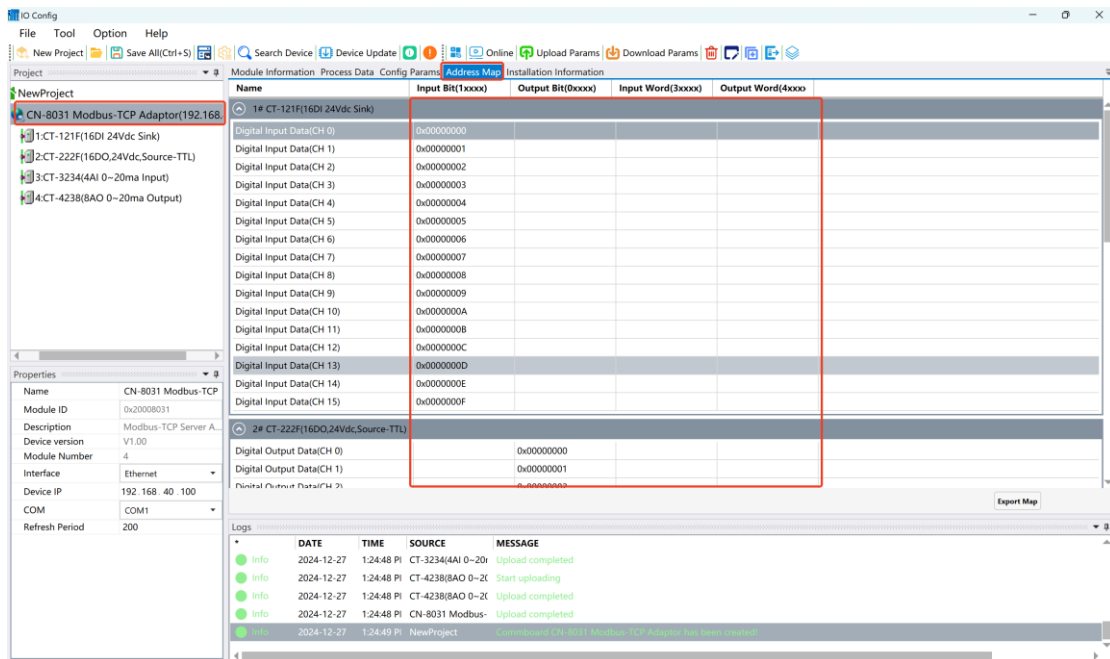

Double-click the Modbus TCP Slave, select the Modbus slave channel, click Add Channel, set parameters such as the channel access type and length, and click OK after the configuration is complete.

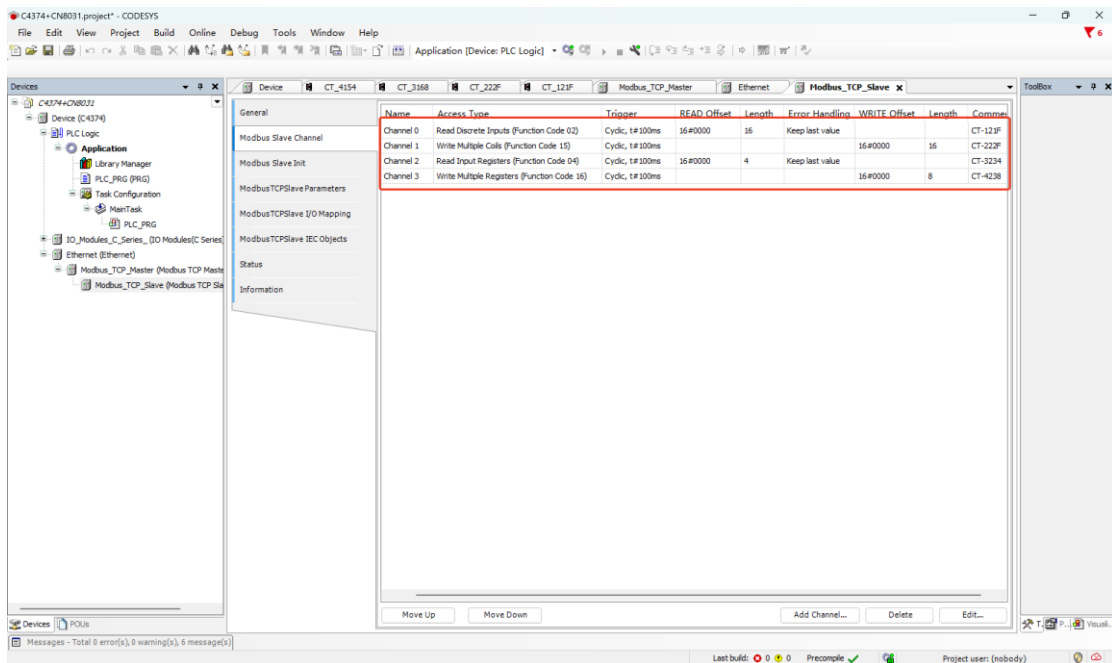
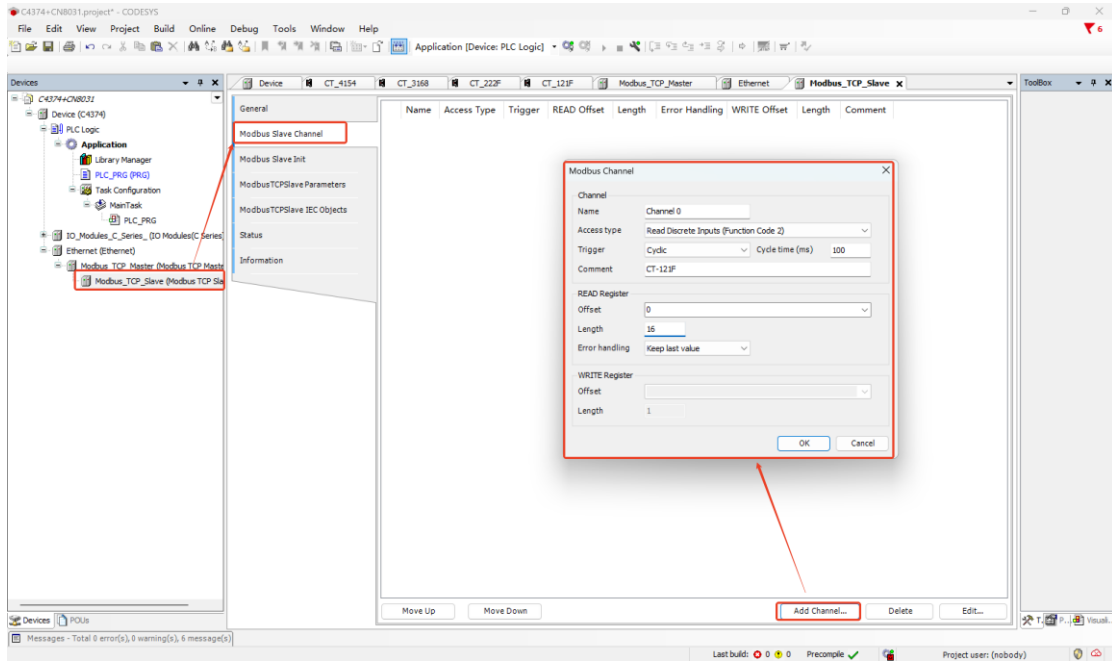

Select Modbus TCP Slave IO Mapping to view the mapped address of the established channel on the C4374 device and set the Always Update variable to Enable 1.

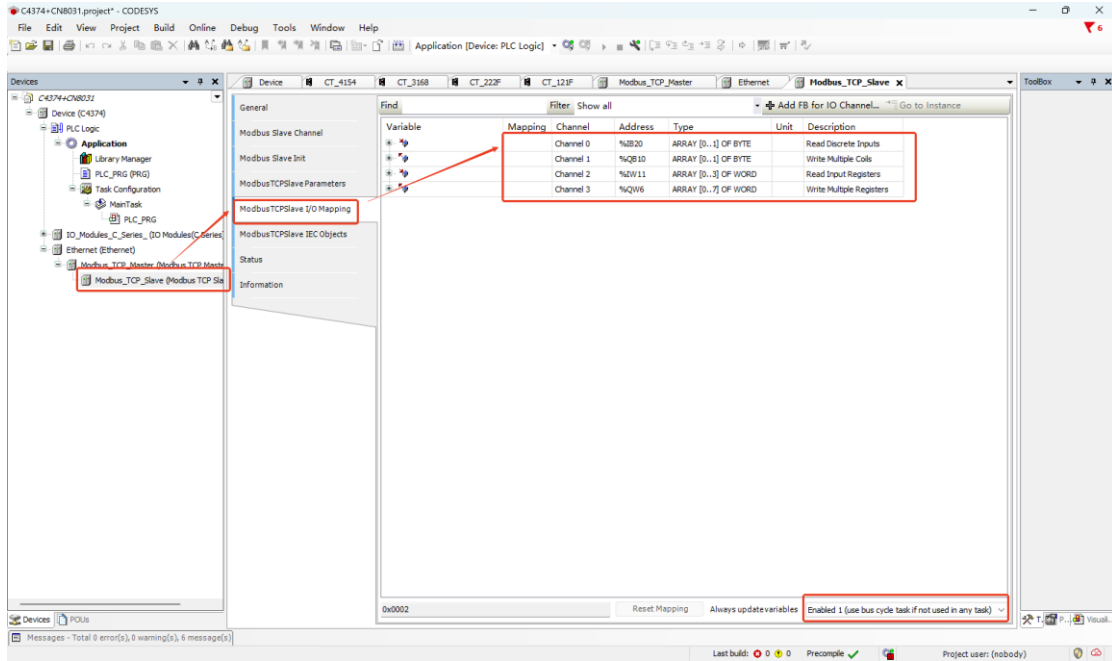

After the parameters are configured, compile and download the program.

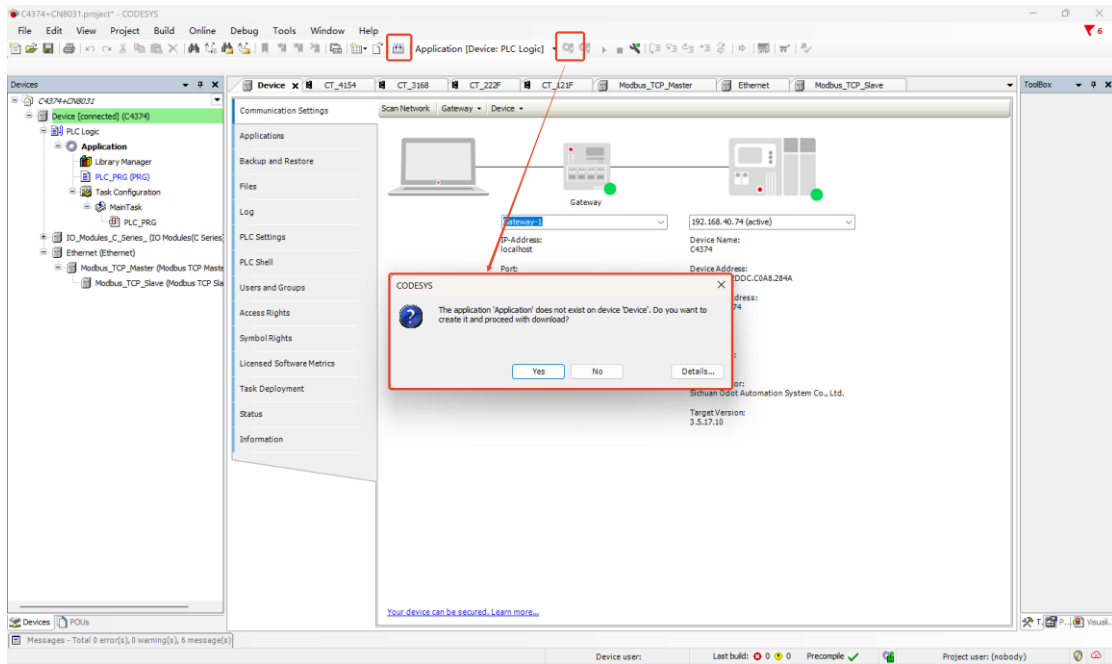

After the configuration is downloaded, can monitor the status of the slave device online.

The screenshot shows the CODESYS interface for configuring a Modbus TCP Slave. The 'ModbusTCPSlave I/O Mapping' window is open, displaying a table of channel mappings. The table includes columns for Channel, Mapping, Address, Type, Current Value, Prepared Value, Unit, and Description. A red box highlights the mapping for Channel 3[7], which is mapped to address %QW13 and is a WORD type.

Channel	Mapping	Address	Type	Current Value	Prepared Value	Unit	Description
Channel 0		%B20	ARRAY [0..1] OF BYTE	Not updated			Read Discrete Inputs
Channel 0[0]		%B20	BYTE	15			Read Discrete Inputs
Channel 0[1]		%B21	BYTE	0			Read Discrete Inputs
Channel 1		%QB10	ARRAY [0..1] OF BYTE	Not updated			Write Multiple Coils
Channel 1[0]		%QB10	BYTE	5			Write Multiple Coils
Channel 1[1]		%QB11	BYTE	2			Write Multiple Coils
Channel 2		%IW11	ARRAY [0..3] OF WORD	Not updated			Read Input Registers
Channel 2[0]		%IW11	WORD	32768			0x0000
Channel 2[1]		%IW12	WORD	32768			0x0001
Channel 2[2]		%IW13	WORD	32768			0x0002
Channel 2[3]		%IW14	WORD	32768			0x0003
Channel 3		%QW6	ARRAY [0..7] OF WORD	Not updated			Write Multiple Registers
Channel 3[0]		%QW6	WORD	3451			0x0000
Channel 3[1]		%QW7	WORD	0			0x0001
Channel 3[2]		%QW8	WORD	0			0x0002
Channel 3[3]		%QW9	WORD	0			0x0003
Channel 3[4]		%QW10	WORD	0			0x0004
Channel 3[5]		%QW11	WORD	0			0x0005
Channel 3[6]		%QW12	WORD	0			0x0006
Channel 3[7]		%QW13	WORD	0			0x0007

6.2 Modbus TCP Server

Topology diagram

C4374 Modbus TCP Server Communication Topology Diagram

Note: The red part of the figure is this case communication topology map

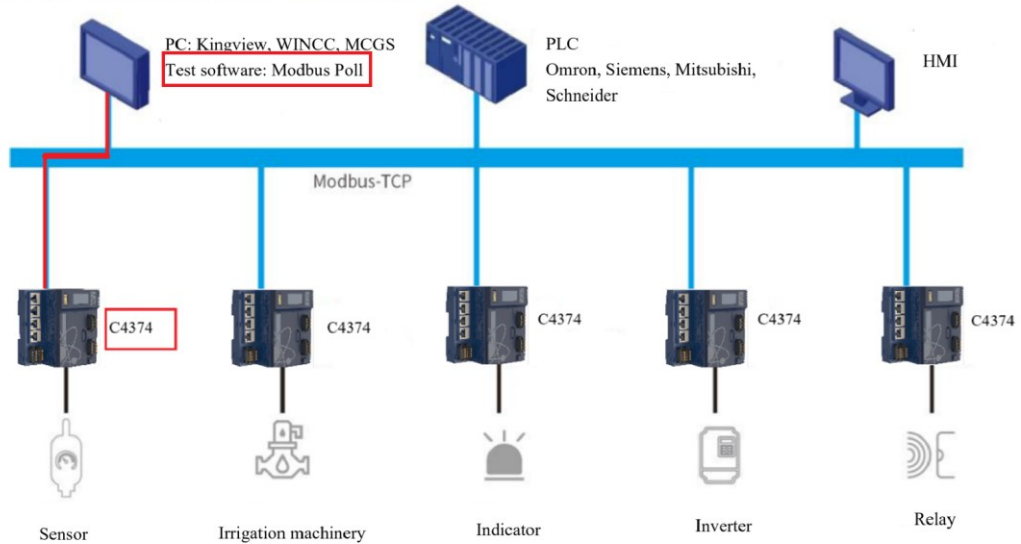

Hardware configuration: C4374+CT-121F+CT-222F+CT-3168+CT-4154;

First, open the Codesys software and click New Project.

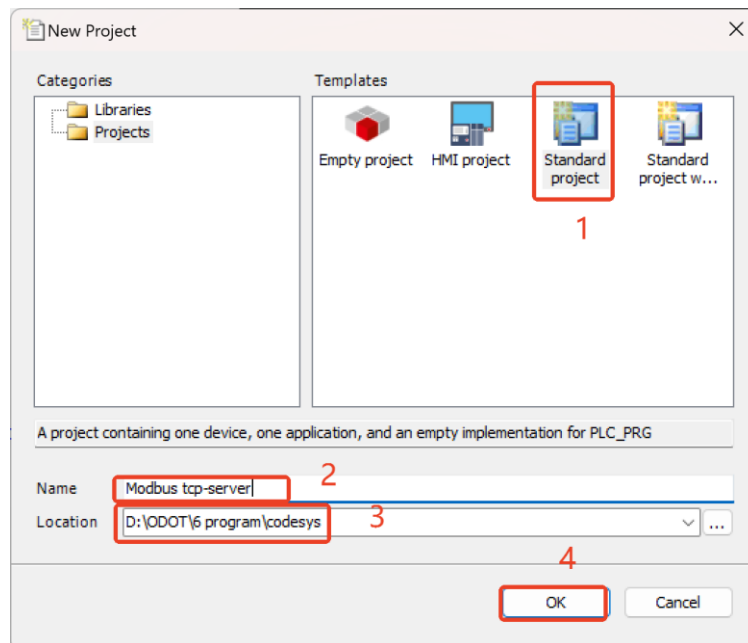

Then select the C4374 device, if can't find the device, refer to the installation device description file, and click OK.

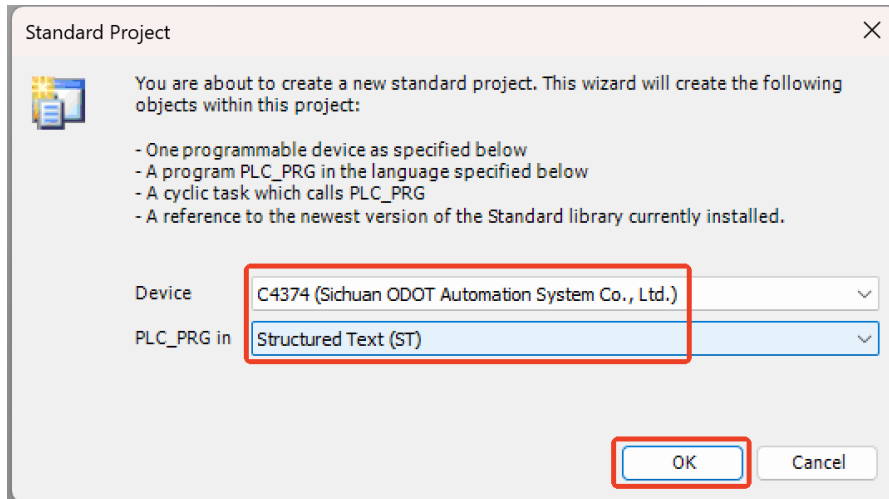

After the project is created, right-click C4374 and select Add Device.

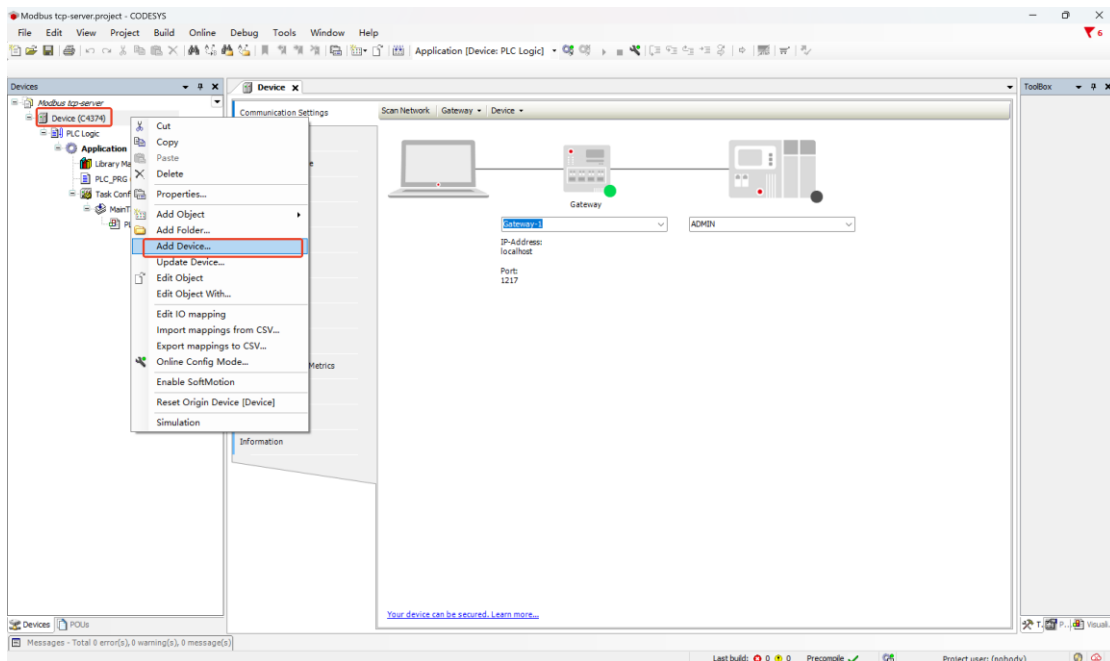

Find "IO Modules" in the pop-up window, select it, click Add Device, and don't need to close this page after adding.

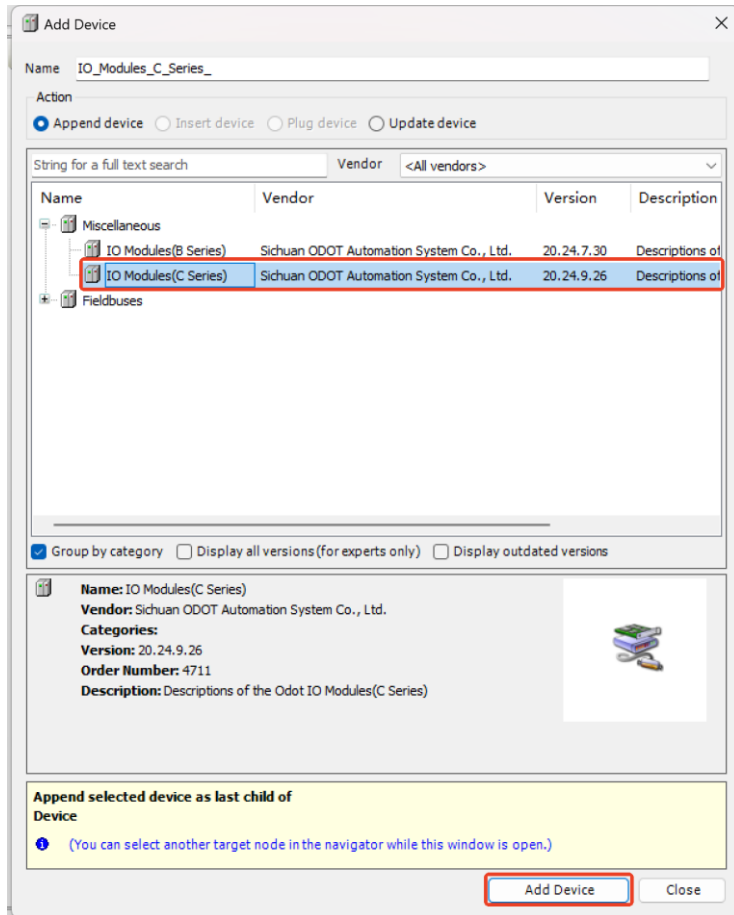

Select the "empty" slot, and insert the corresponding module according to the hardware configuration, and the functions of the module are listed in the selection table.

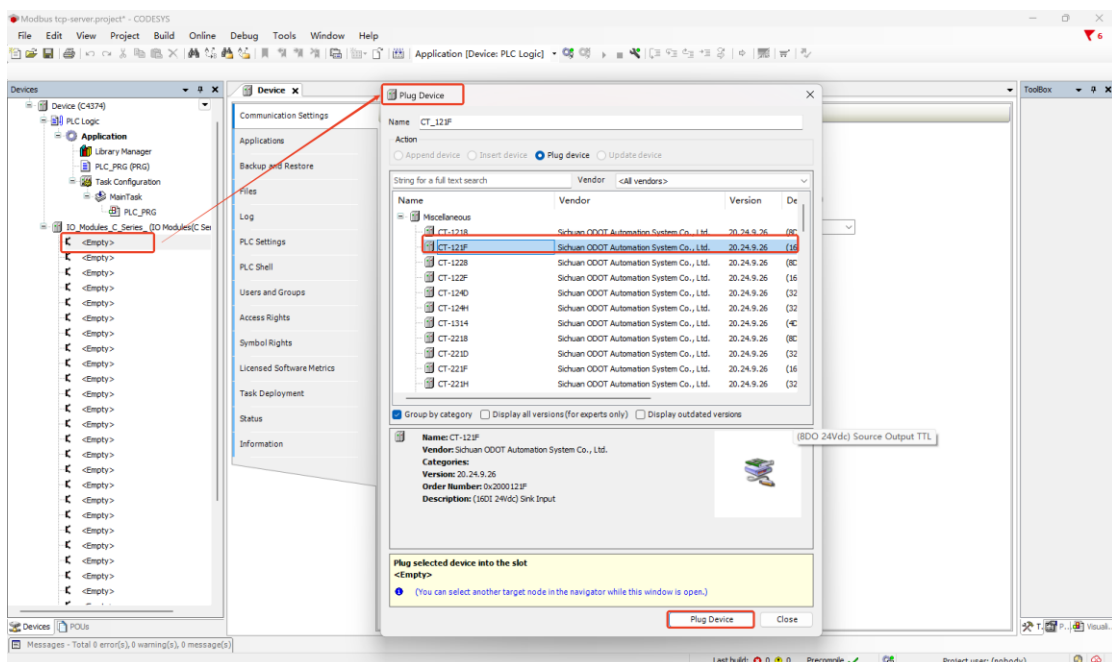

Double-click the module and select I/O Mapping to view the corresponding I/O address and set the mapping relationship.

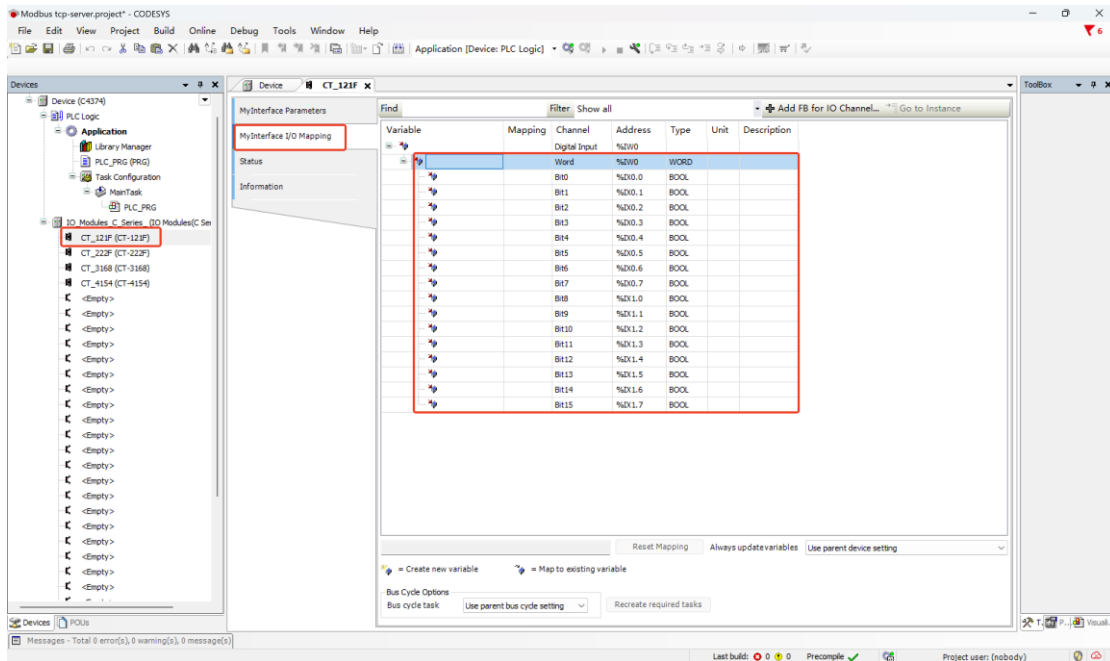

Set the Always Update variable to enable 1 (or use the bus cycle task if not used in any task).

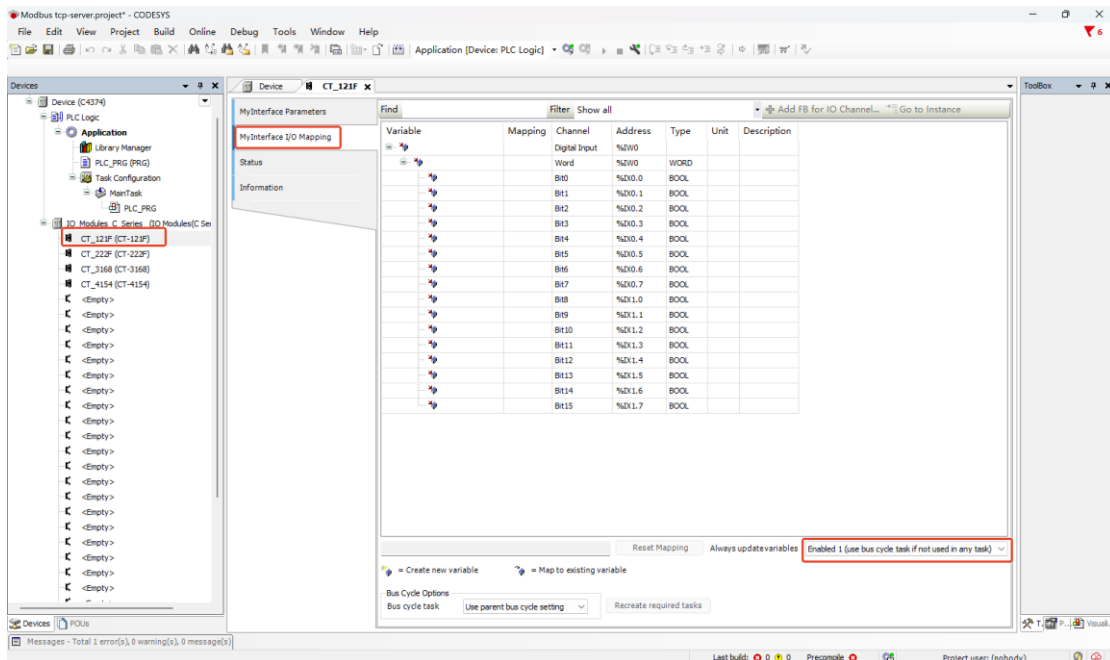

Right-click on C4374, select Add Device, select Ethernet Adapter, and click Add Device.

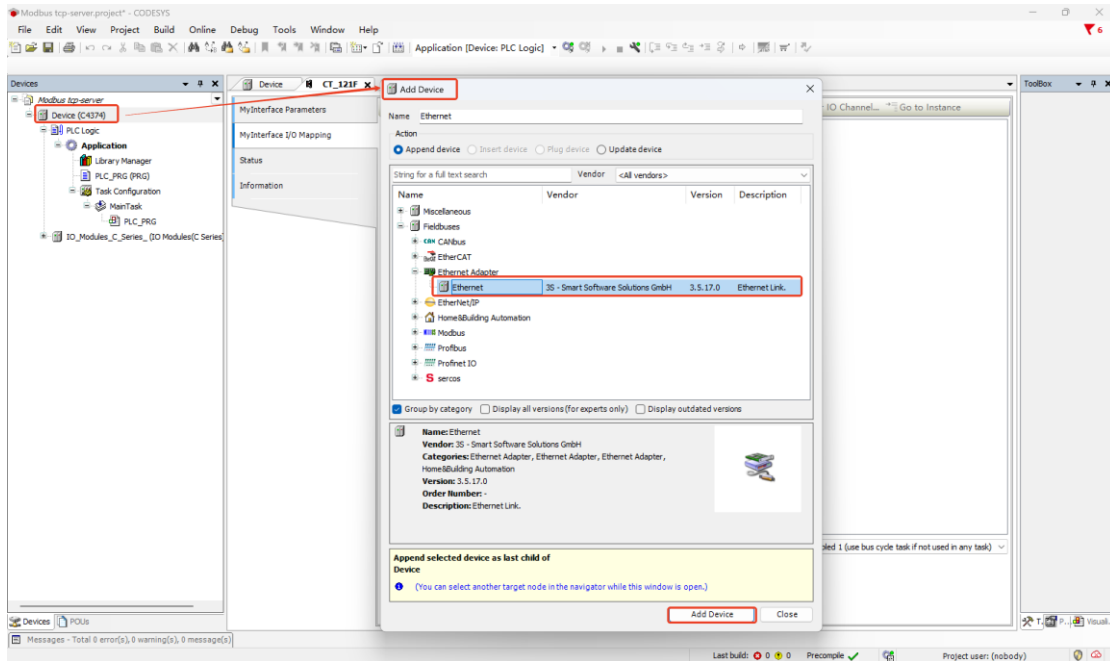

Right-click Ethernet, select Add Device, select “Modbus TCP Slave—Modbus TCP Slave Device”, and click Add Device.

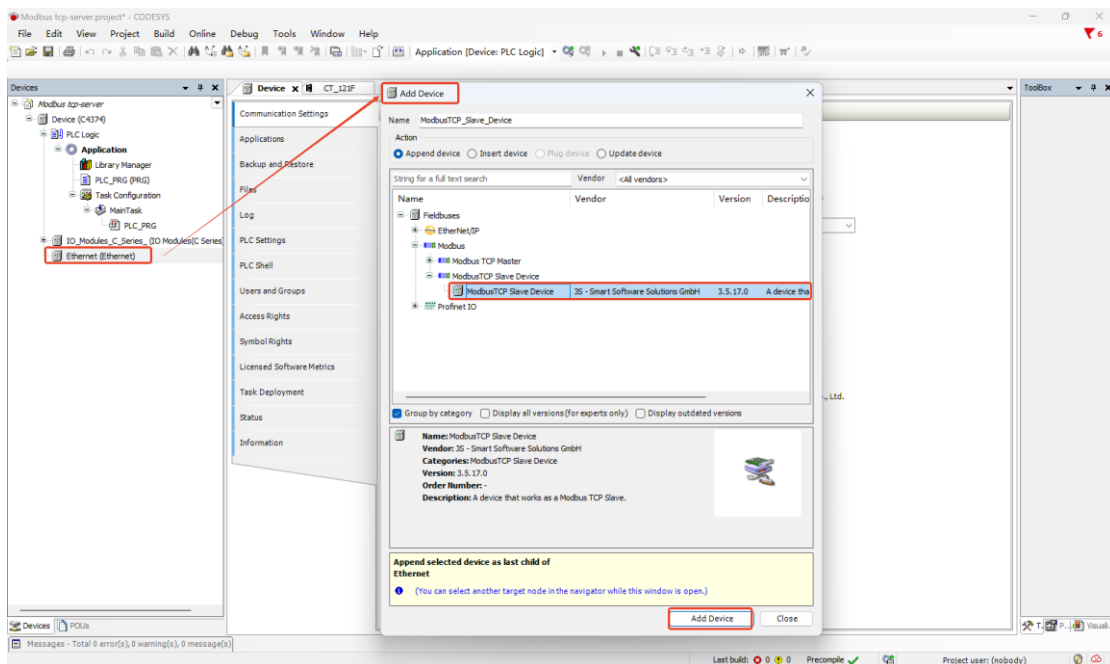

Double-click Device (C4374), select Communication Settings, enter the IP address of the C4374 module (the IP address of the module can be viewed through the LCD display), and press Enter to activate the device.

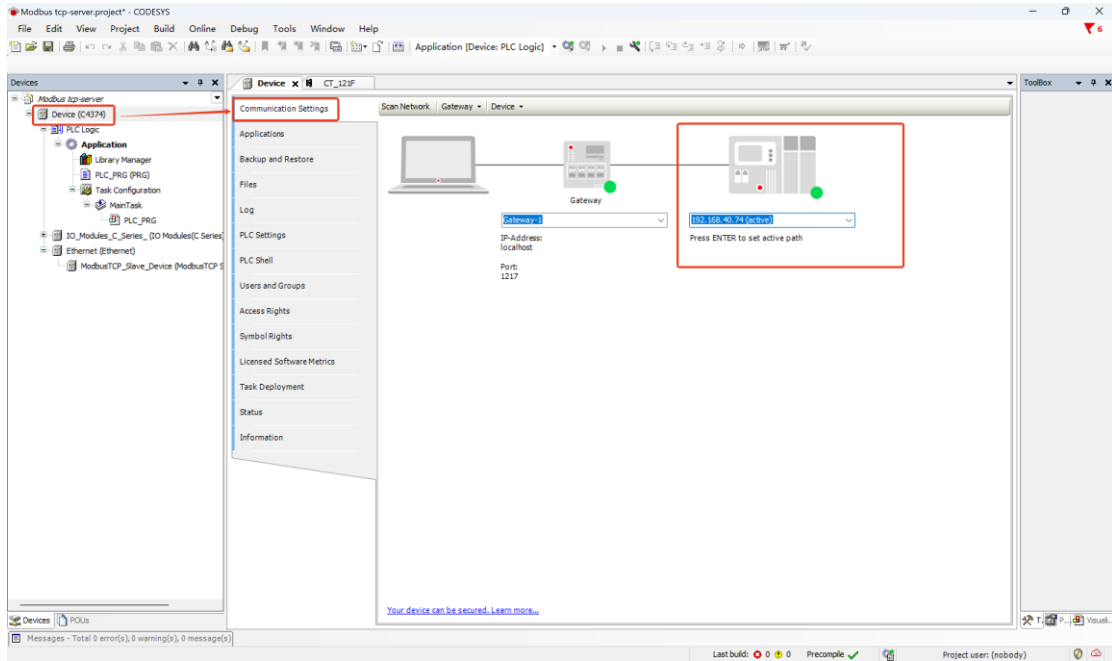

Double-click Ethernet, select General, click "Browse" at the network interface, select the corresponding network adapter, and click OK.

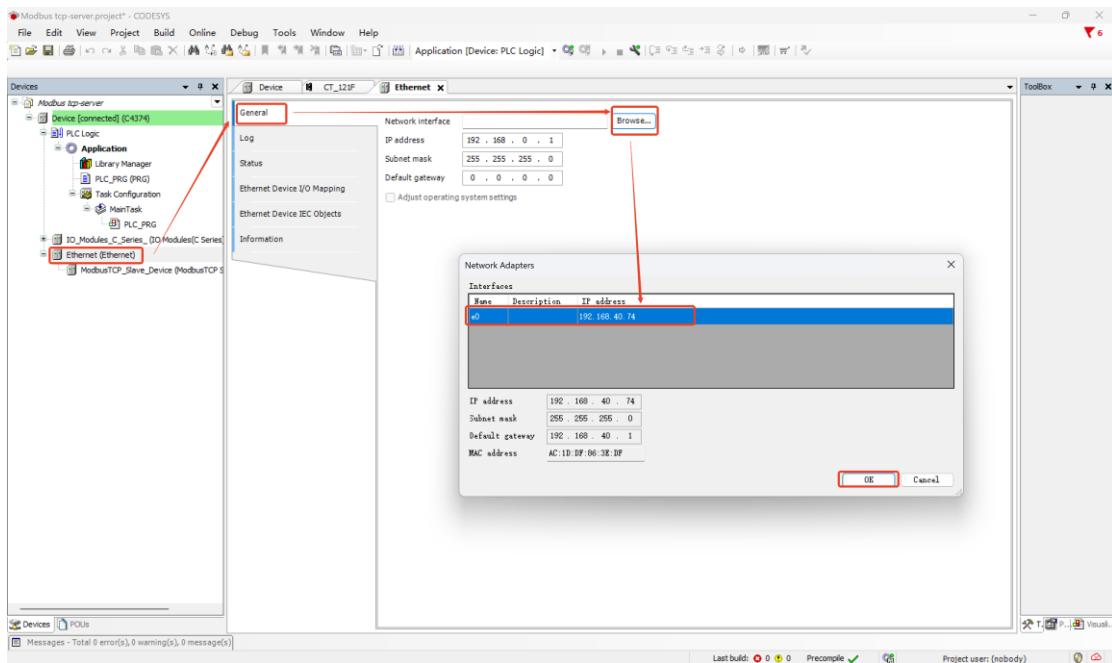

Next, the server is parameterized with a third-party client, which is simulated using the "Modbus Poll" software.

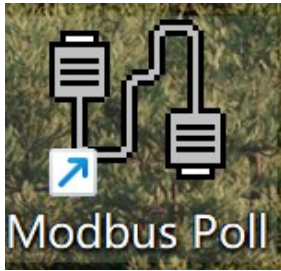

Double-click "Modbus TCP Slave Device", select "General" on the main interface on the right, set the slave port number in the configuration parameters, set the length of the holding register, input register, coil, and discrete input parameters, and modify the start address of the parameter in the data type.

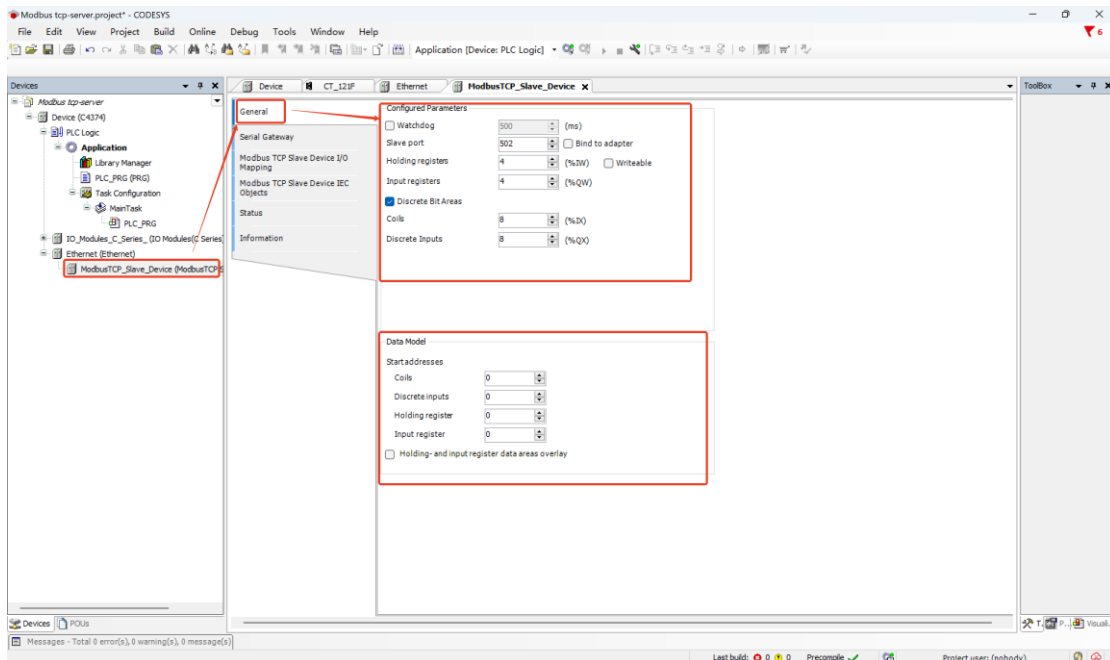

After the parameters are configured, select Modbus TCP Slave Device I/O Mapping to view the mapped address of the newly established slave device on the C4374 device, and set the Always Update variable to enable 1 (if not used in any task, use the bus periodic task).

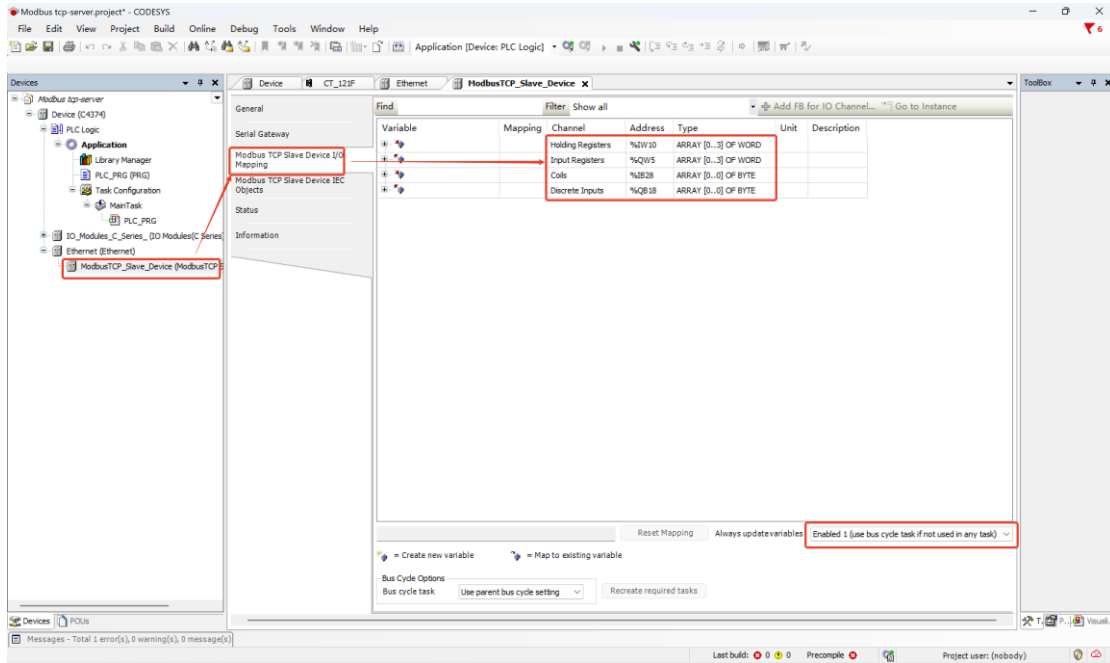

Next, open the client emulation software “Modbus Poll”, “Ctrl+N” create two Mbpoll windows, right-click in the blank space of the two windows to select “Read/Write Definition”, the Function of first window is selected “03 Read Holding Registers(4x)”, “Quantity” set to the length of the hold register set in Codesys; The Function of second window is selected “04 Read Input Register(3x)”, “Quantity” set to the length of the input register set in Codesys; The Function of third window is selected “15 Write Multiple Coils(0x)”, “Quantity” set to the coil length set in Codesys; The Function of fourth window is selected “02 Read Discrete Input Register(1x)”, “Quantity” set to the discrete input length set in Codesys.

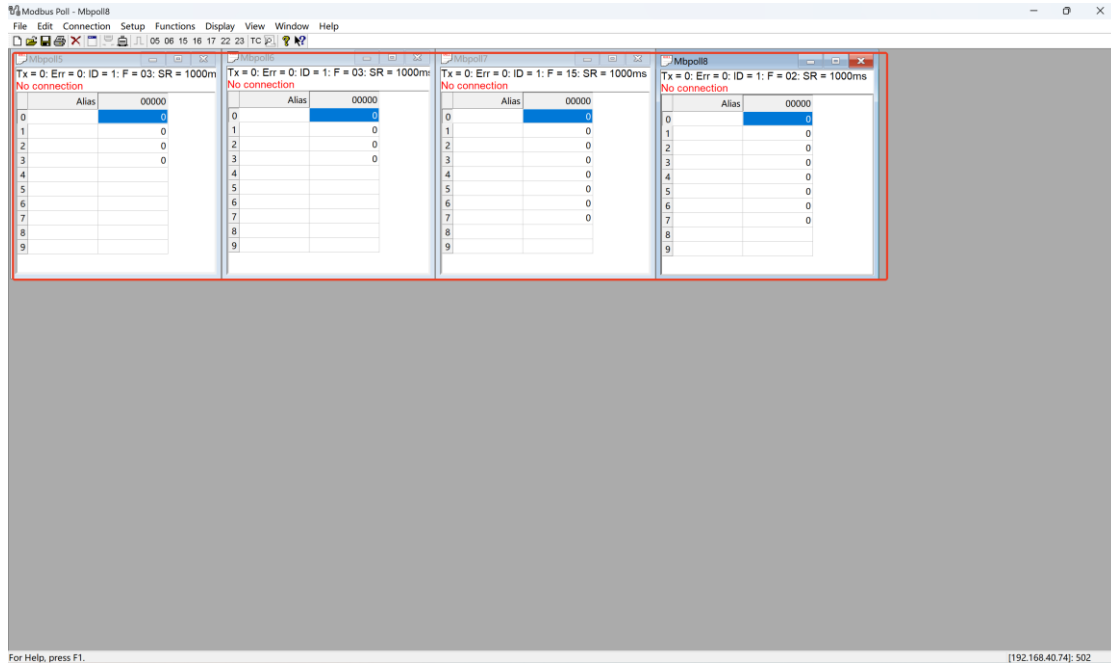

After completion, go back to the Codesys software, download and log in to the C4374 device again, and the error will disappear after the TCP client is connected.

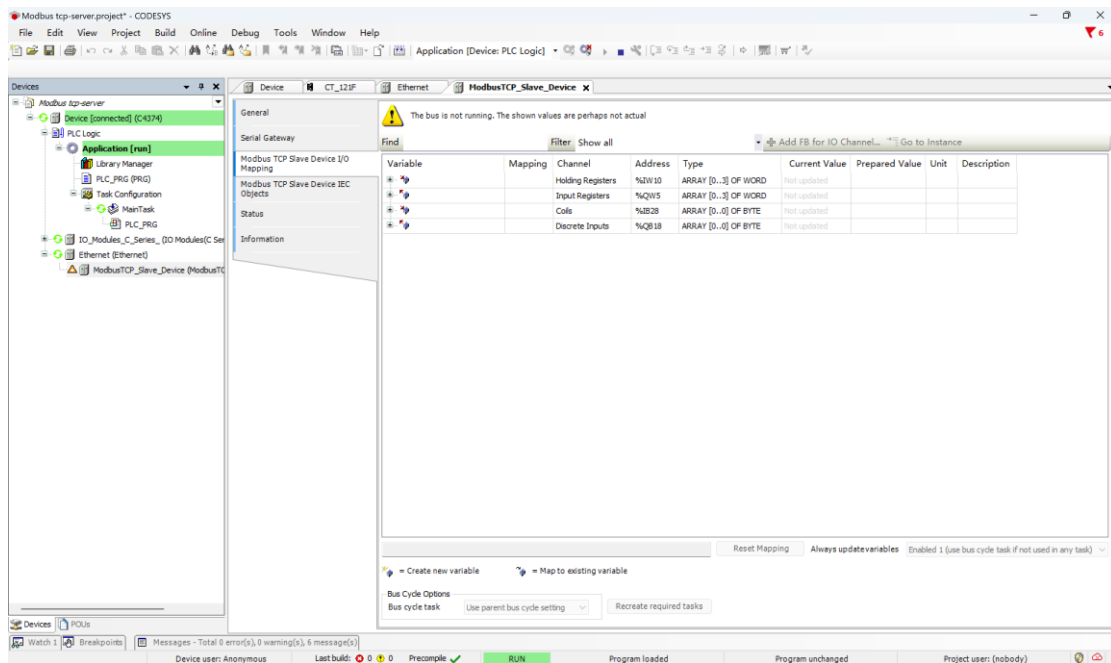

Back to Modbus Poll software, click “Connection--Connect” or use the shortcut key F3 to connect, in the pop-up interface set the “Connection” as “Modbus TCP/IP”, enter the IP address and port number, and click OK after the configuration is complete.

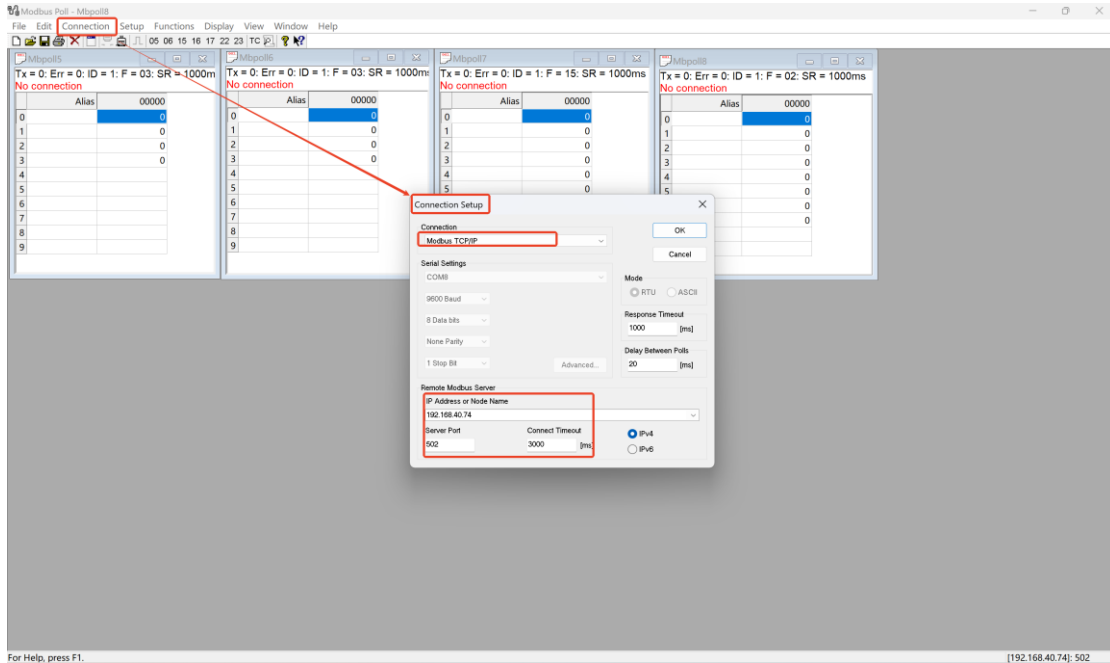

Go back to the Codesys software and see that all the devices are working fine.

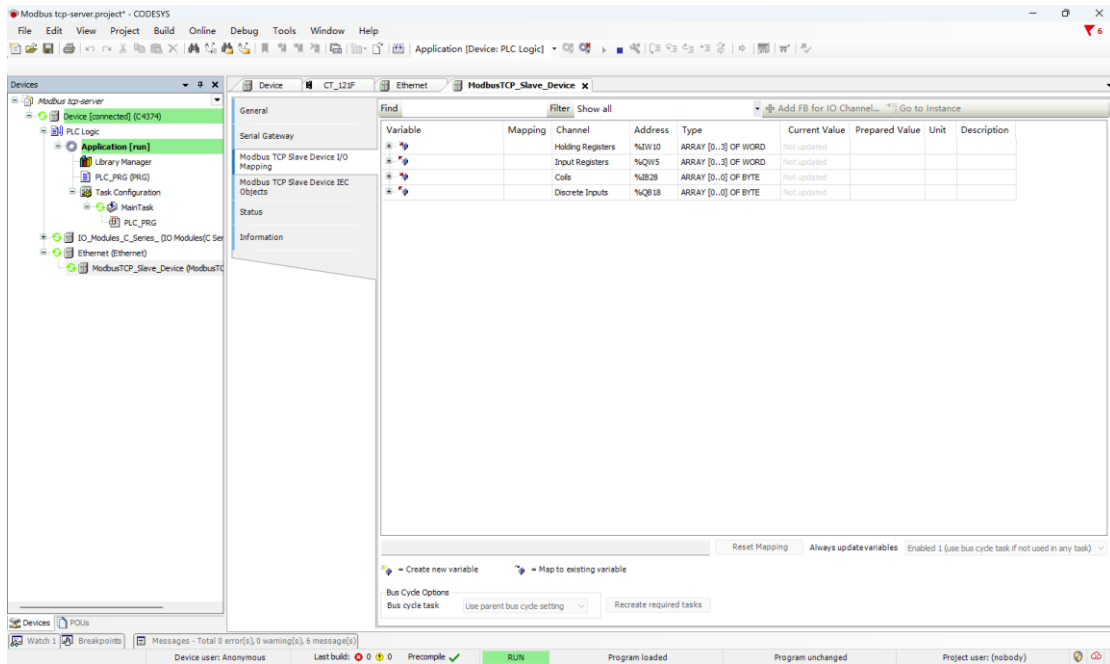

Set the prepared value in the Codesys software, select "Debug - Write Value", or use the shortcut key "Ctrl+F7" to write, and the value change can also be monitored in the Modbus Poll software; Values from the Modbus Poll software can also be read in the Codesys software.

Modbus TCP Server project - CODESYS

Application [run] (C4374)

ModbusTCP_Slave_Device (ModbusTCP)

Variable	Mapping	Channel	Address	Type	Current Value	Prepared Value	Unit	Description
Holding Registers			%W10	ARRAY [0..3] OF WORD	Not updated			
Holding Registers[0]			%W10	WORD	413			
Holding Registers[1]			%W11	WORD	987			
Holding Registers[2]			%W12	WORD	561			
Holding Registers[3]			%W13	WORD	781			
Input Registers			%QW5	ARRAY [0..3] OF WORD	Not updated			
Input Registers[0]			%QW5	WORD	5143			
Input Registers[1]			%QW6	WORD	713			
Input Registers[2]			%QW7	WORD	549			
Input Registers[3]			%QW8	WORD	892			
Coils			%B28	ARRAY [0..] OF BYTE	Not updated			
Coils[0]			%B28	BYTE	89			
Discrete Inputs			%QB18	ARRAY [0..] OF BYTE	Not updated			
Discrete Inputs[0]			%QB18	BYTE	6			

Device user: Anonymous Last build: Precompile RUN Program loaded Program unchanged Project user: (nobody)

Modbus Poll - Mipoll3

Tx = 91: Err = 0: ID = 1: F = 03: SR = -

Alias	00000
0	413
1	987
2	561
3	781
4	
5	
6	
7	
8	
9	

Tx = 221: Err = 0: ID = 1: F = 04: SR = 10

Alias	00000
0	5143
1	713
2	549
3	892
4	
5	
6	
7	
8	
9	

Tx = 221: Err = 0: ID = 1: F = 15: SR = 1000r

Alias	00000
0	1
1	0
2	0
3	1
4	1
5	0
6	1
7	0
8	
9	

Tx = 221: Err = 0: ID = 1: F = 02: SR = 100

Alias	00000
0	0
1	1
2	1
3	0
4	0
5	0
6	0
7	0
8	0
9	

For Help, press F1. [192.168.40.74]: 502

6.3 Modbus RTU Master

Topology diagram

C4374 Modbus RTU Communication topology diagram

Note: The red part of the figure is this case communication topology map

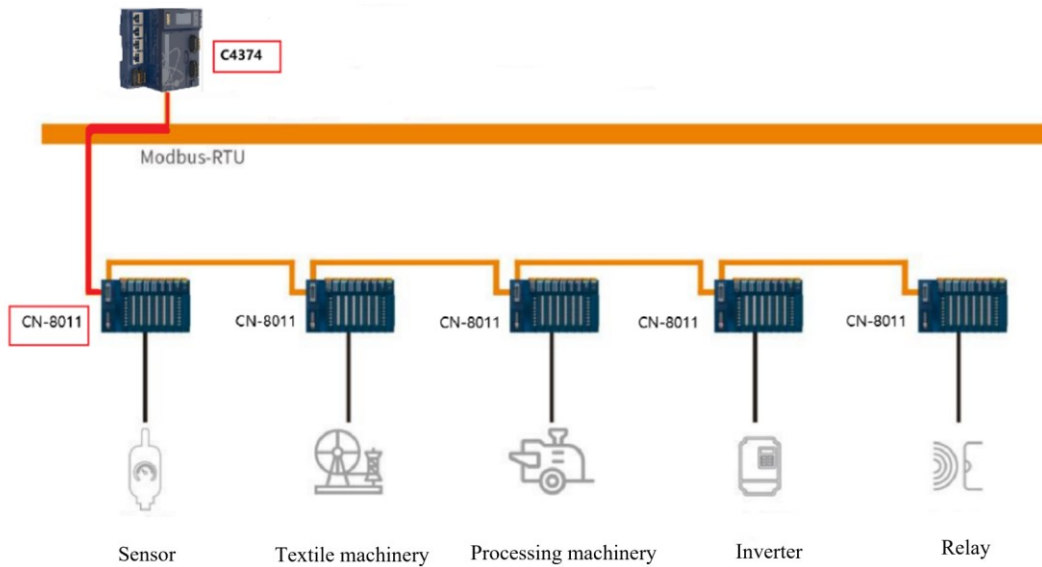

Hardware configuration: C4374+CT-121F+CT-222F+CT-4154+CT-3168+CT-3724+CT-5801; CN-8011+CT-121F+CT-222F+CT-3234+CT-3134;

First, open the Codesys software and click New Project.

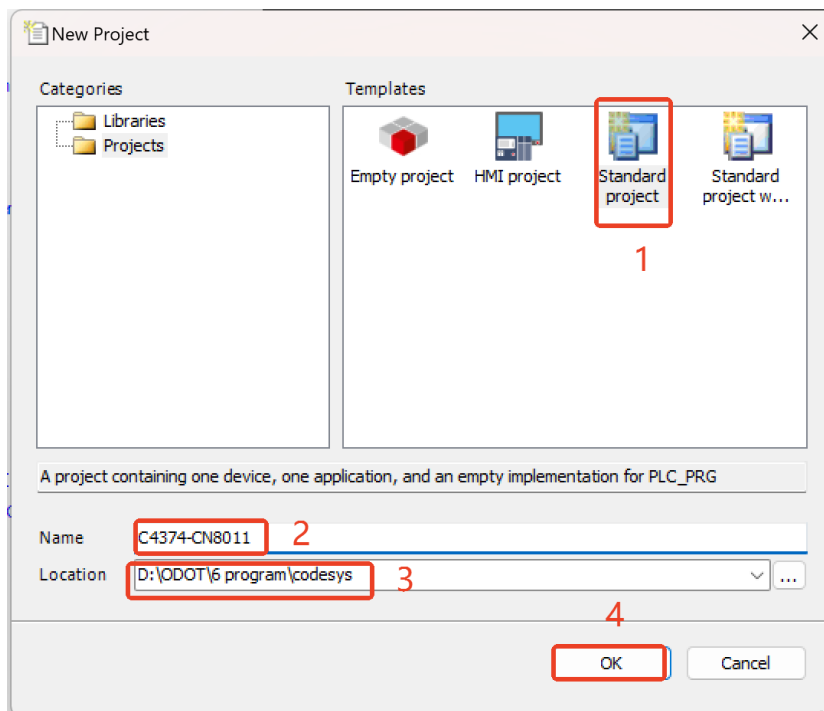

Then select the C4374 device, if can't find the device, refer to the installation device description file, and click OK.

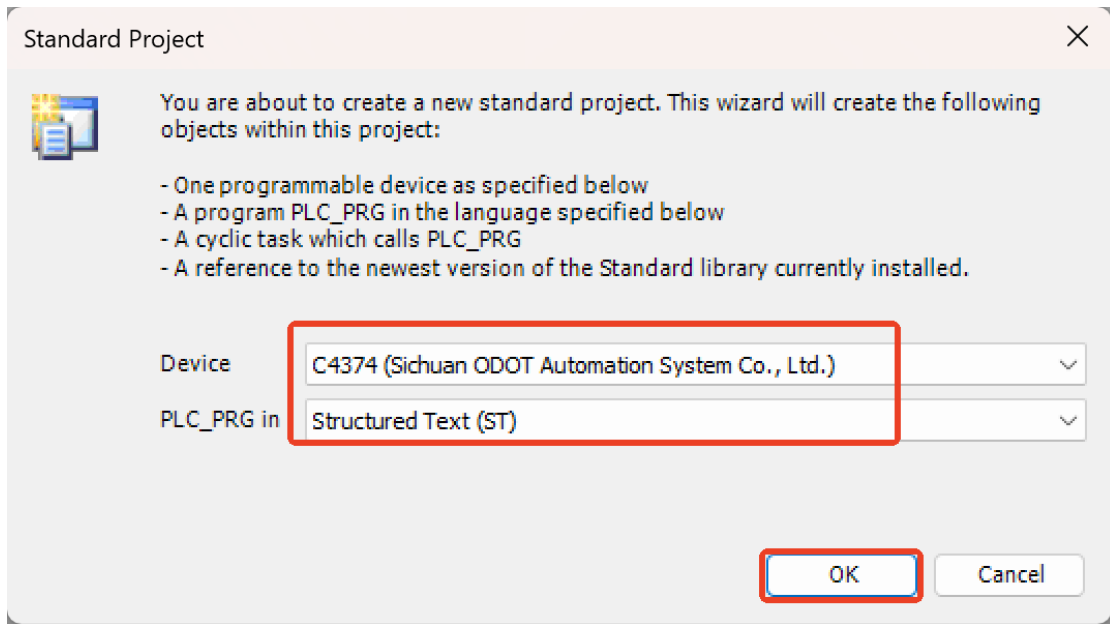

After the project is created, right-click C4374 and select Add Device.

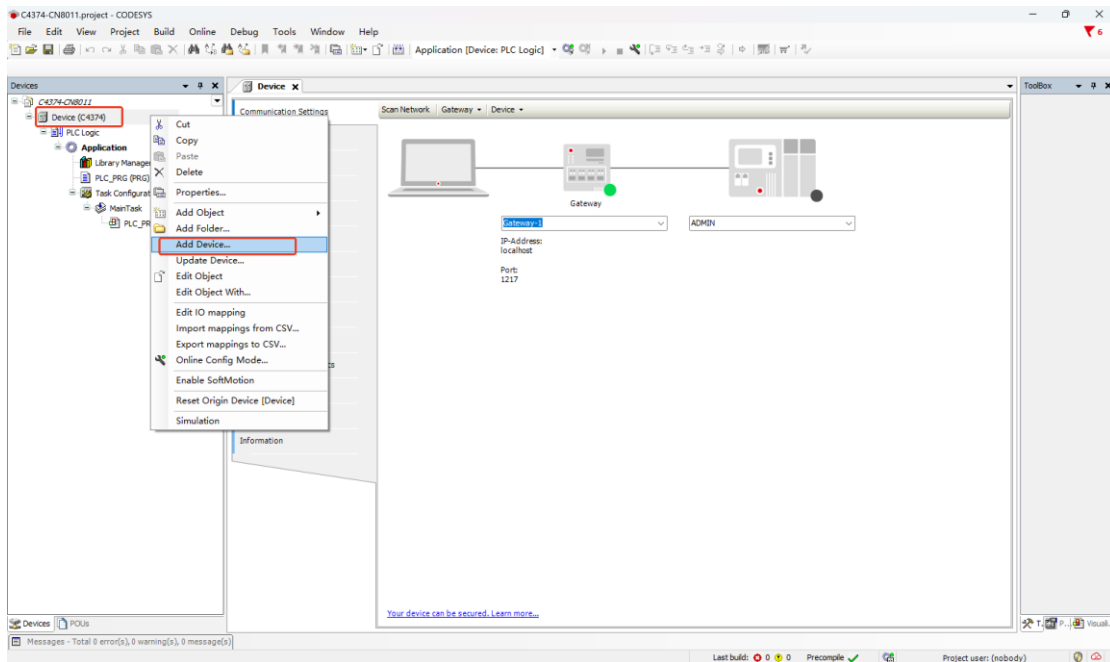

Find "IO Modules" in the pop-up window, select it, click Add Device, and don't need to close this page after adding.

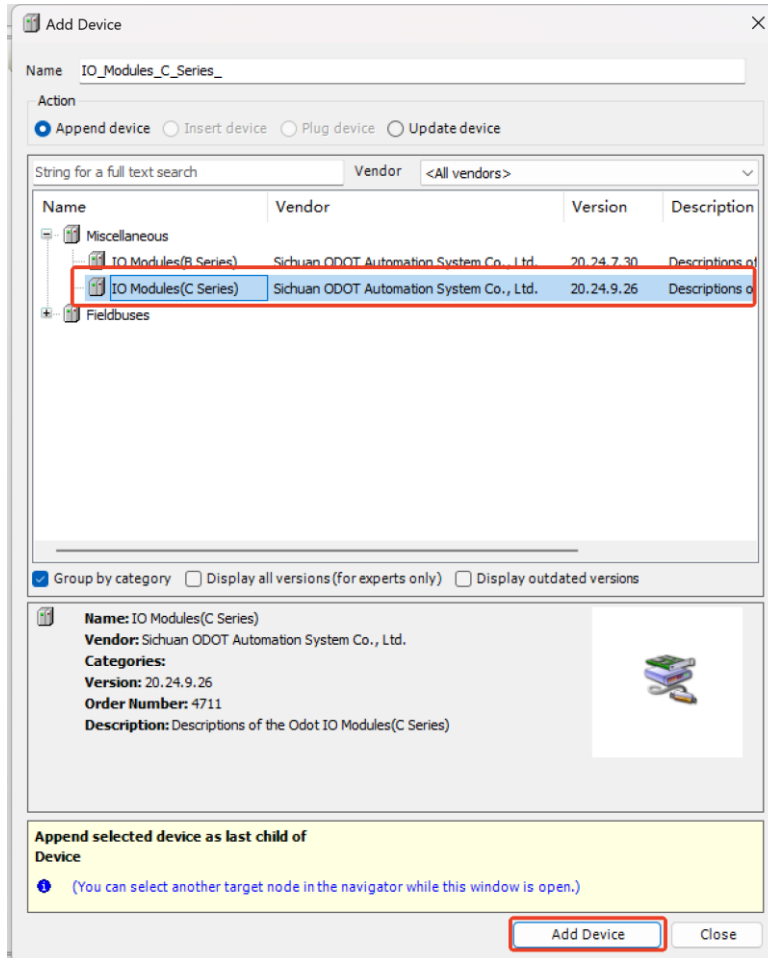

Select the "empty" slot, and insert the corresponding module according to the hardware configuration, and the functions of the module are listed in the selection table.

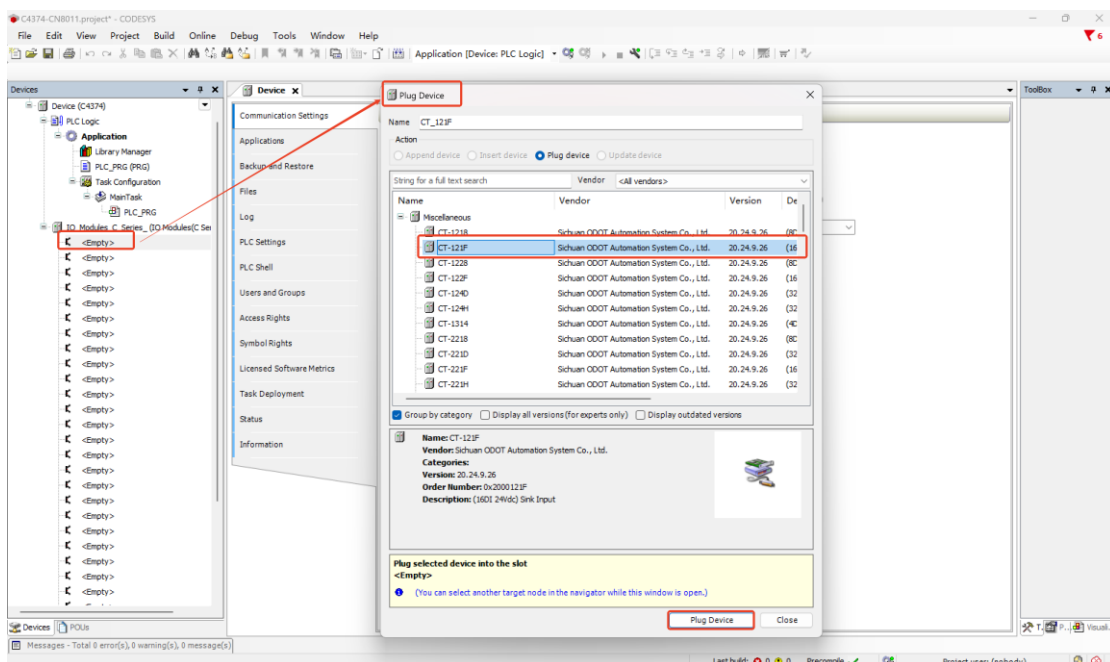

Double-click the module and select I/O Mapping to view the corresponding I/O address, set the mapping relationship, and set the Always Update variable to Enable 1.

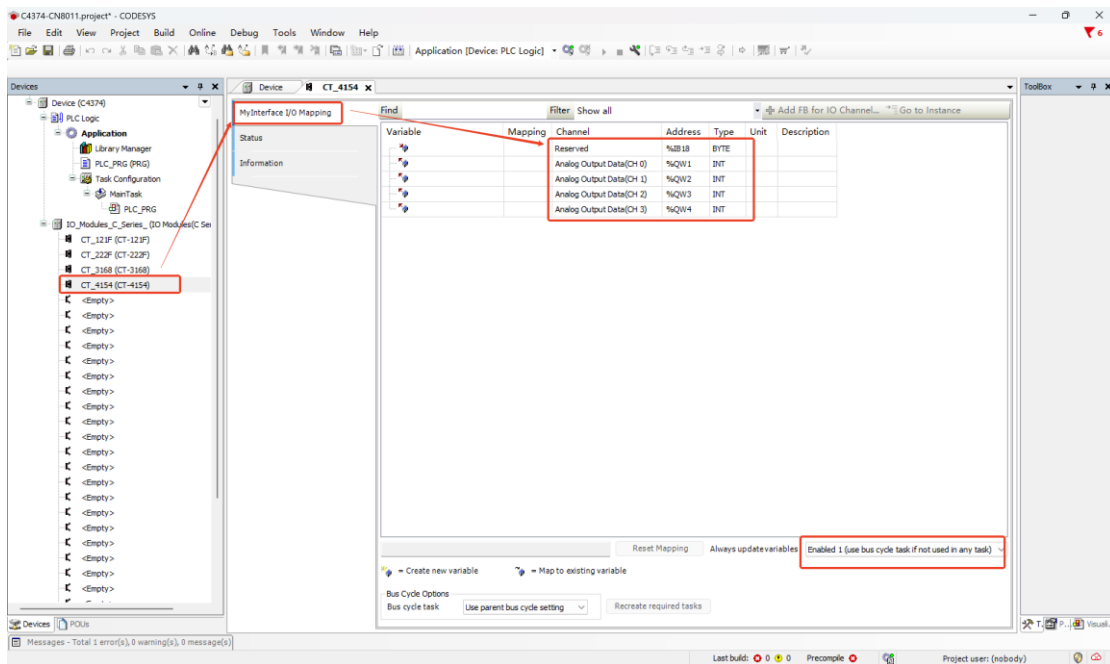

Right-click C4374, select Add Device, select "Modbus—Modbus Serial Port—Modbus COM", and click Add Device to close the "Add Device" window.

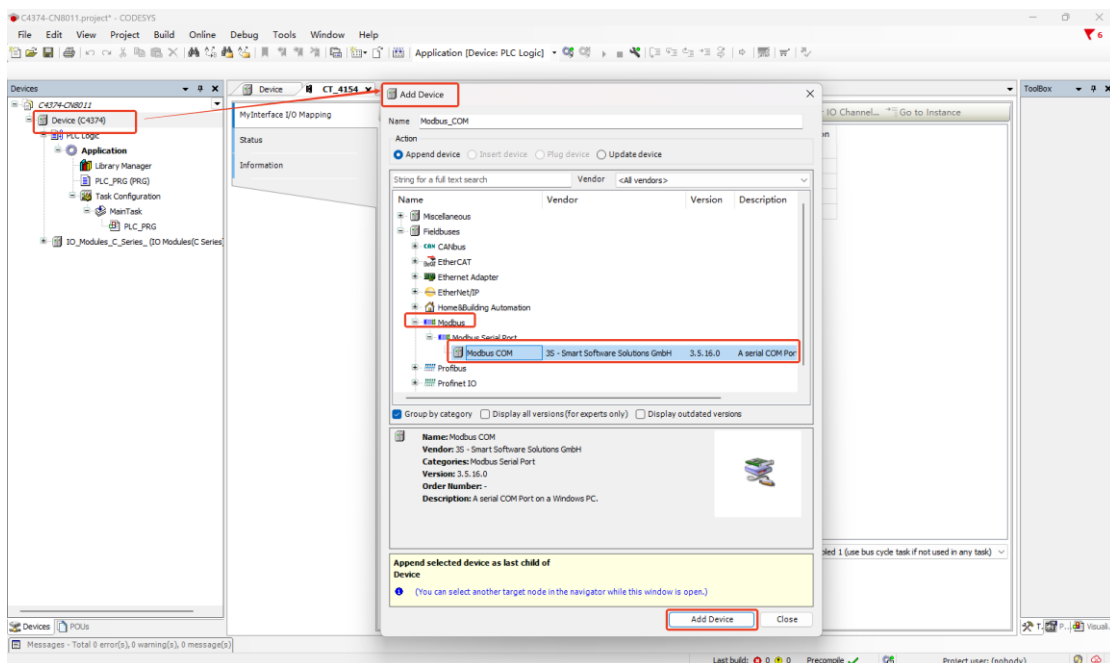

Select Modbus COM, select Modbus Serial Master - Modbus Master in the Add Device window, and click Add Device.

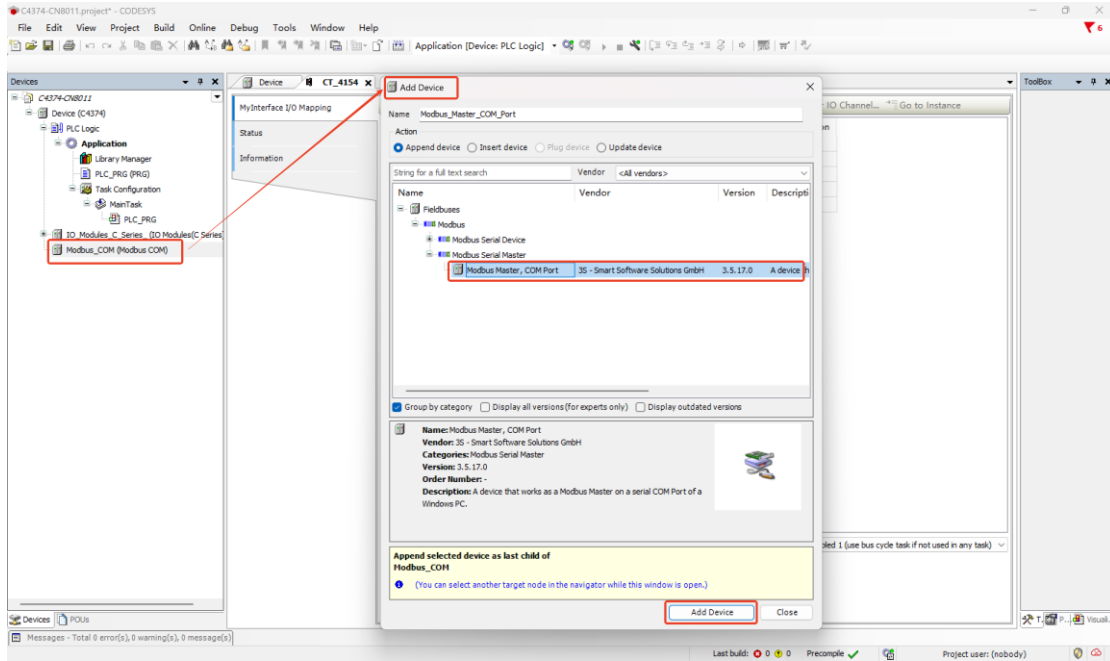

Select Modbus Master COM Port, on the Add Device page, select Modbus Slave and click Add Device.

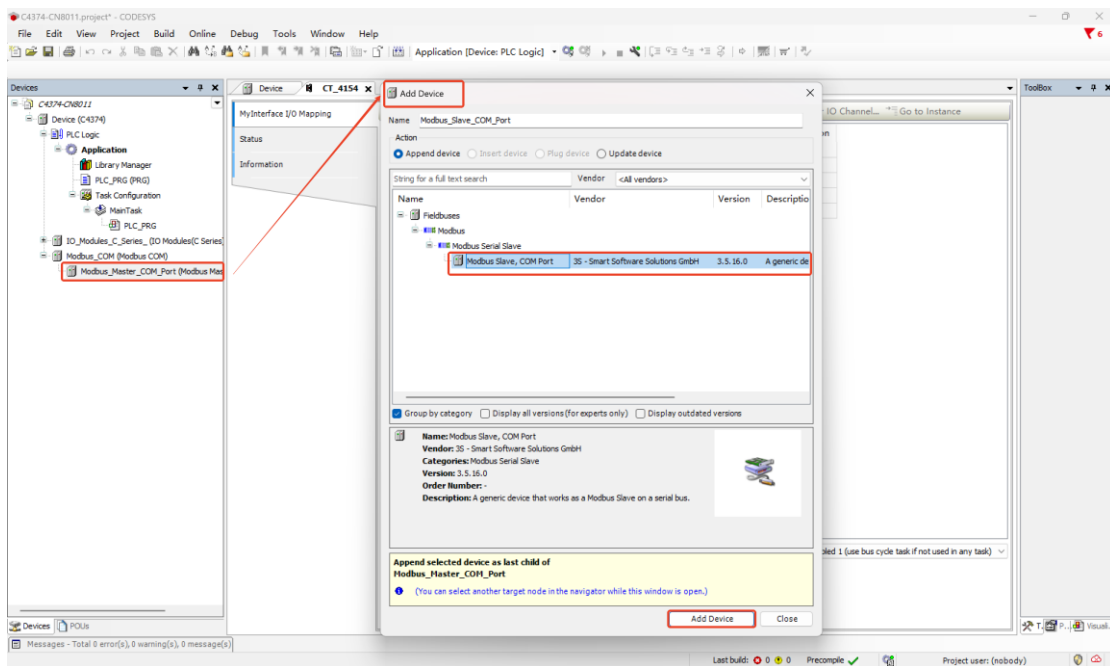

It can use the IO Config software to view the communication configuration parameters of the CN-8011 module, select CN-8011, and click Configure Parameters.

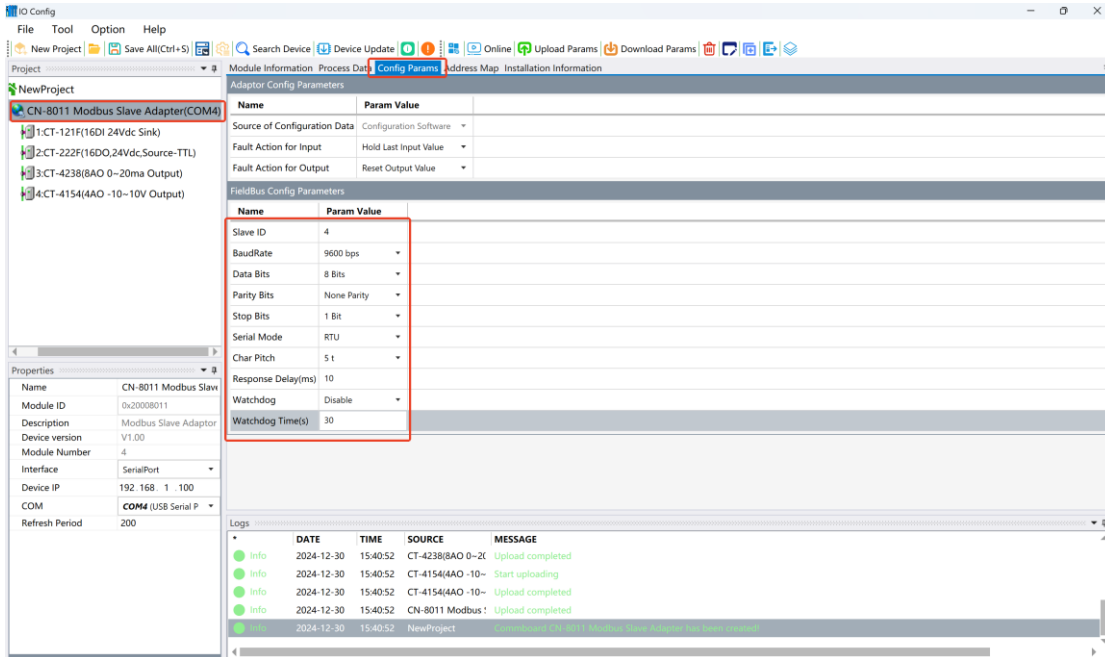

Double-click Modbus COM, select General-Serial Port Configuration, set the baud rate to 9600, parity: None, data bit: 8, stop bit: 1.

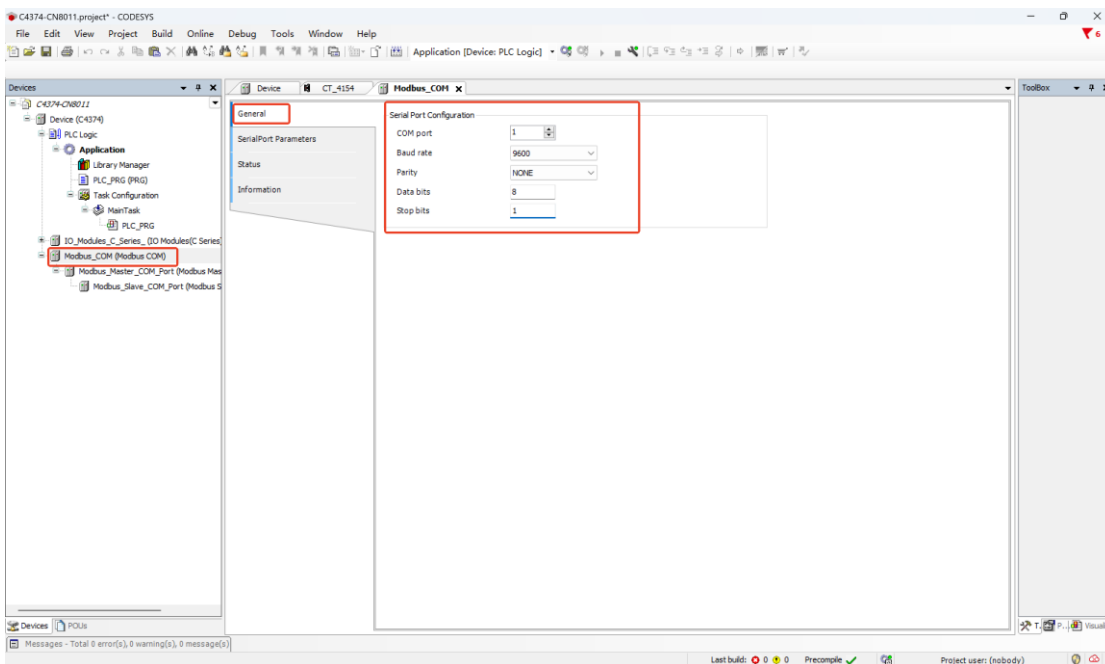

Double-click the Modbus Master COM Port, select General, set the transmission mode to RTU, set the response timeout and frame interval time, and select Auto Restart Communication.

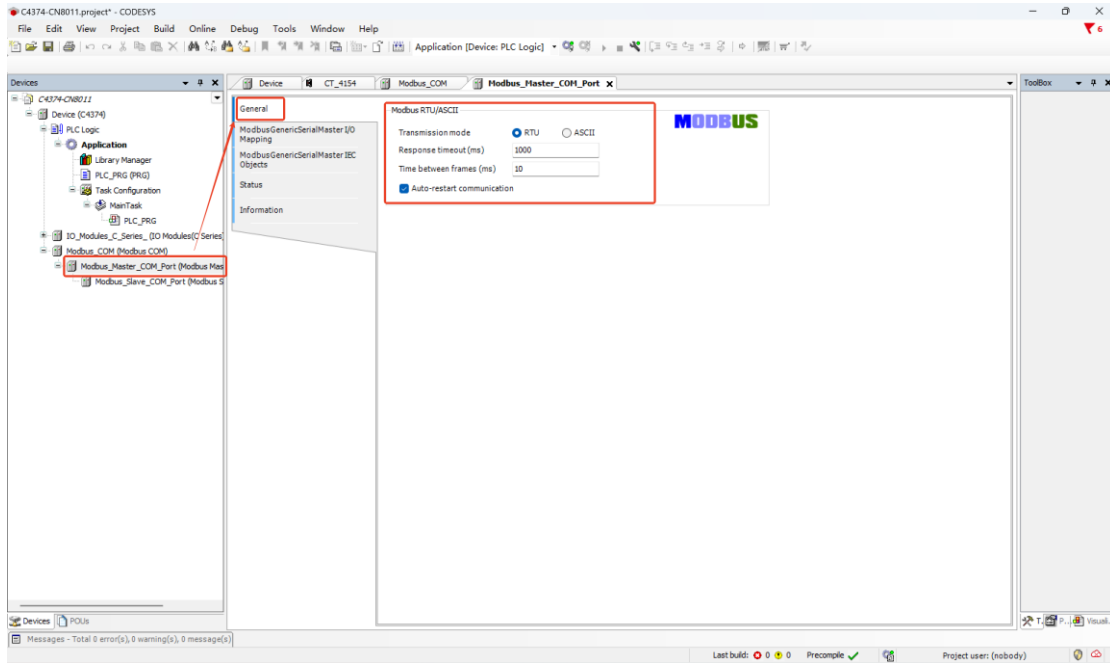

Double-click the Modbus Slave COM Port, select General, and set the Modbus slave address to 4 to modify the response timeout.

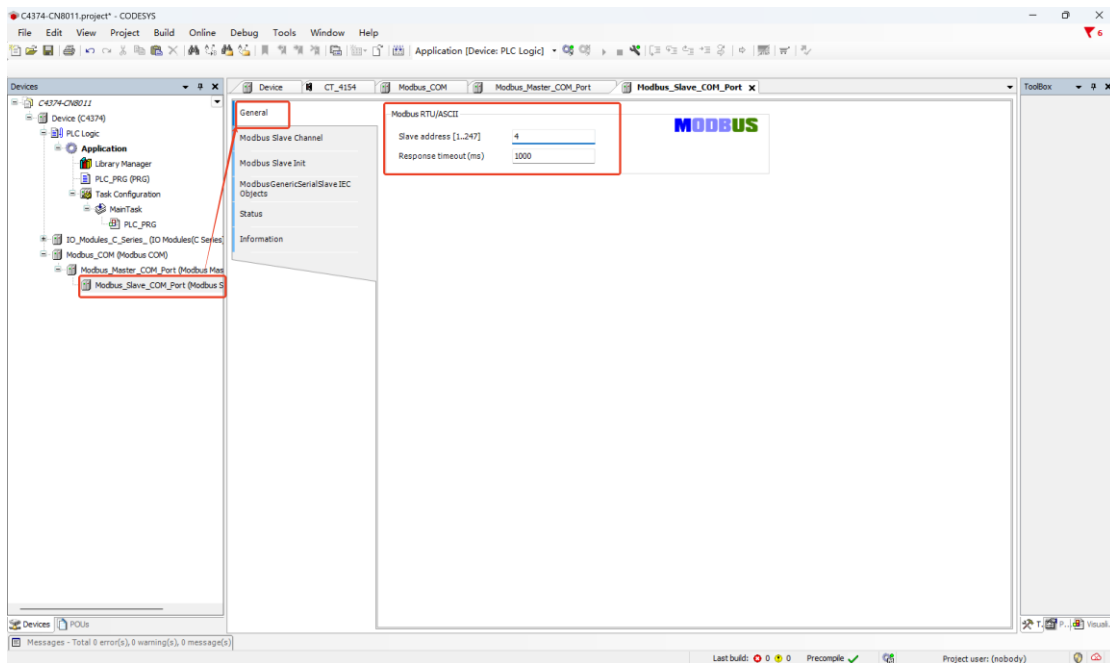

It can use the IO Config software to view the address mapping relationship of the CN-8011 module, select CN-8011, and click the address table.

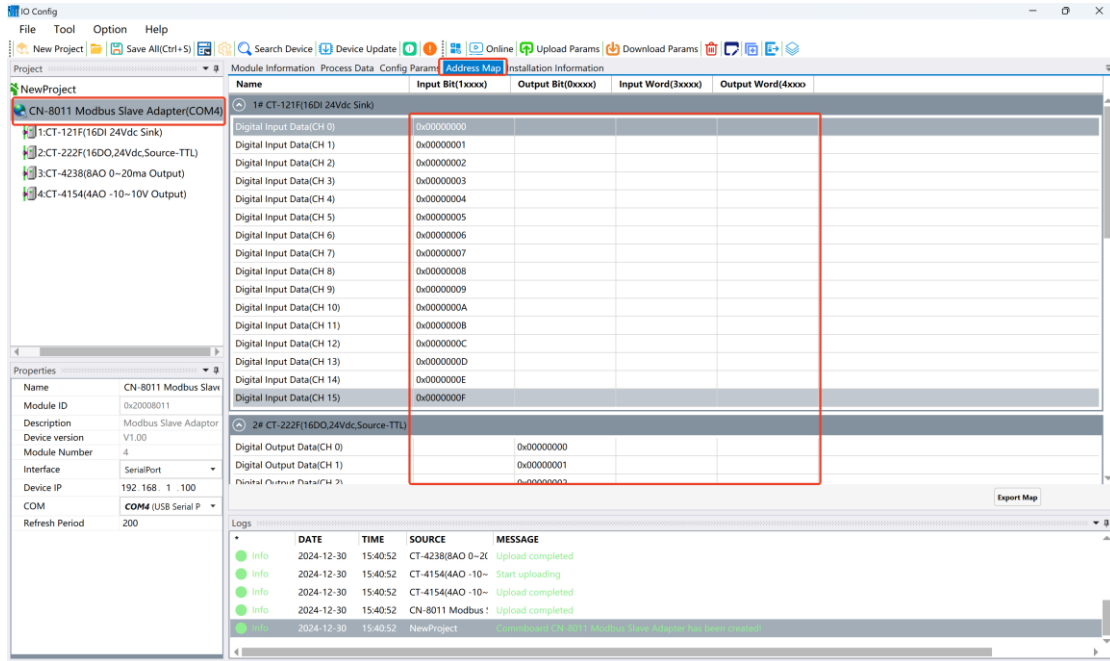

Configure parameters based on the address mapping table. Select "Modbus Slave COM Port—Modbus Slave Channel—Add Channel", set the channel name, access type, length and other parameters, and click OK after the configuration is complete.

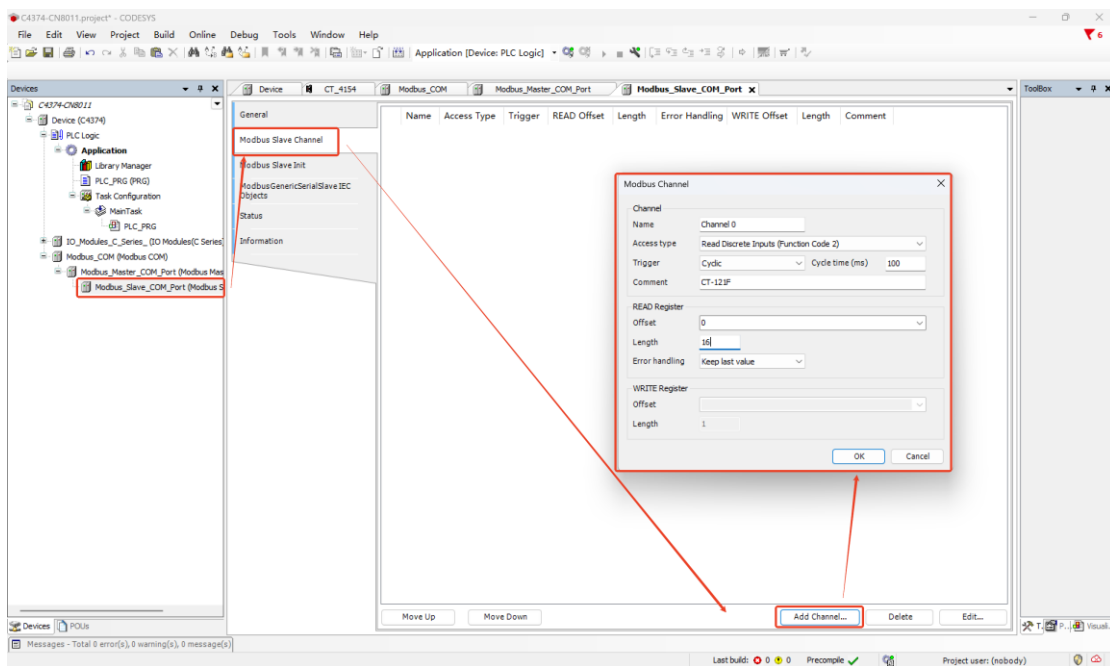

After all channel parameters are configured, as shown in the following figure.

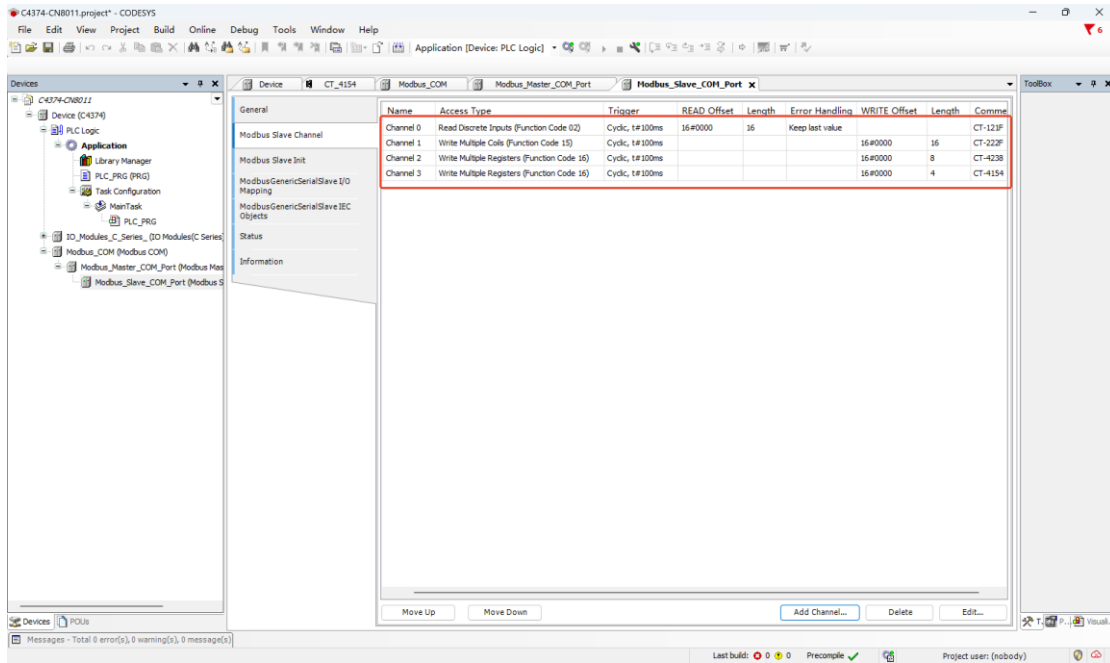

Select Modbus Slave COM Port—IO Mapping to view the mapping address of the newly established channel on the C4374 device, and set the Always Update variable to Enable 1.

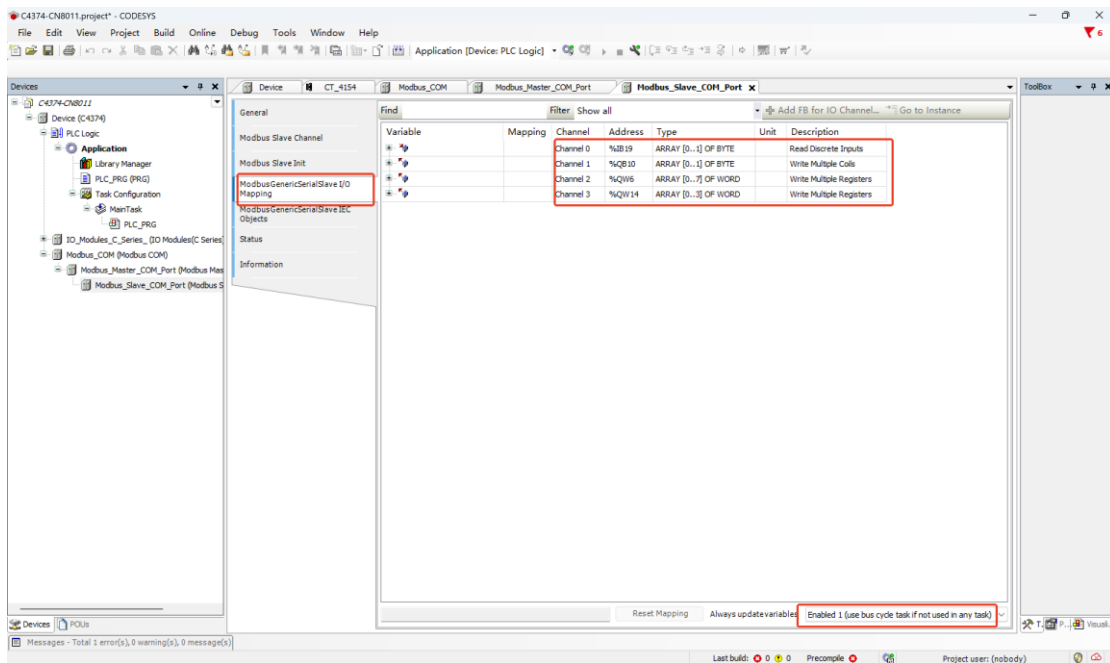

After the parameters are configured, first log in to the C4374 device. Then compile the downloader.

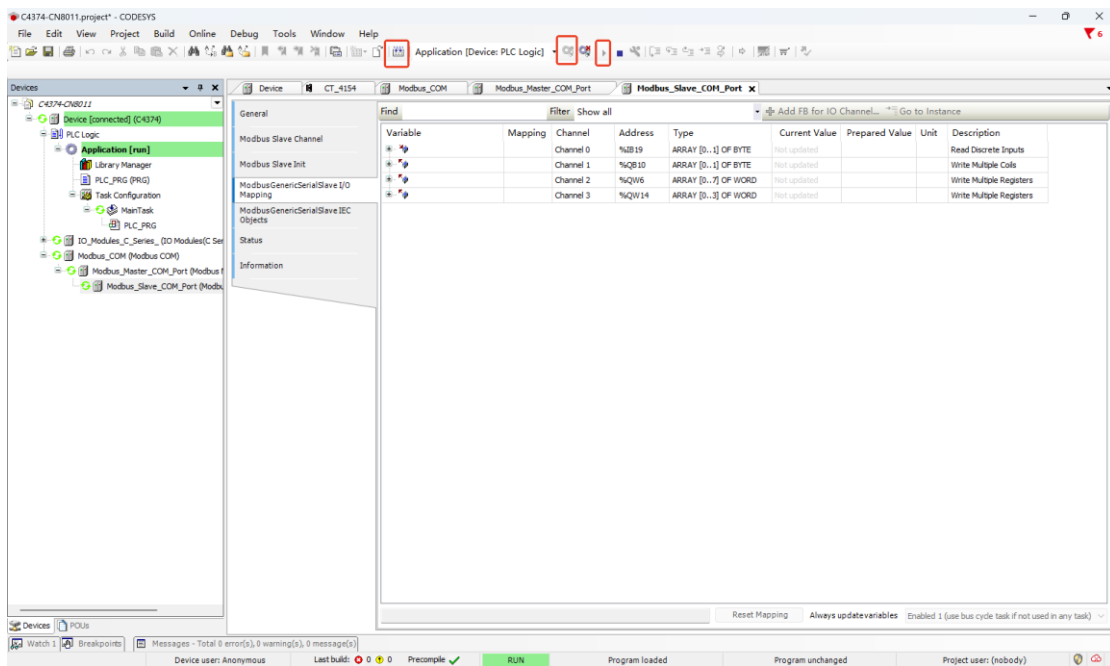
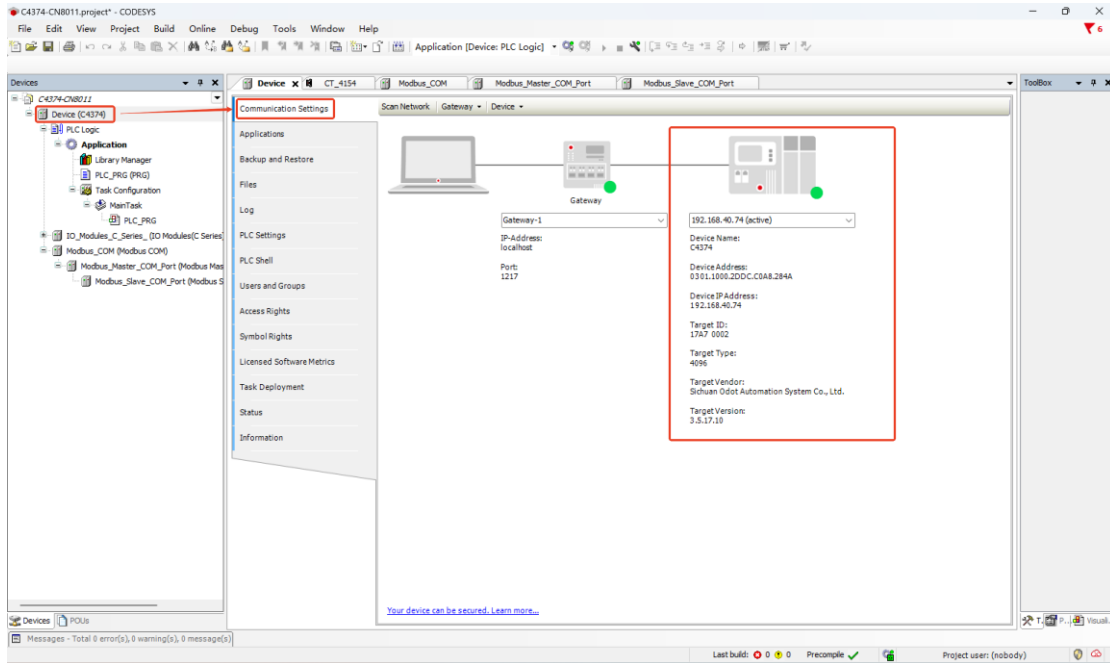

Select “Modbus Slave COM Port—IO Mapping” to view the data of the CN-8011 module.

The screenshot shows the CODESYS interface for configuring a Modbus Slave Channel. The 'Modbus_Slave_COM_Port' window is active, displaying a table of channel mappings. The table is outlined in red and contains the following data:

Variable	Mapping	Channel	Address	Type	Current Value	Prepared Value	Unit	Description
		Channel 0	%B19	ARRAY [0..1] OF BYTE	Not updated			Read Discrete Inputs
		Channel 0[0]	%B19	BYTE	32			Read Discrete Inputs
		Channel 0[1]	%B20	BYTE	0			Read Discrete Inputs
		Channel 1	%QB10	ARRAY [0..1] OF BYTE	Not updated			Write Multiple Coils
		Channel 1[0]	%QB10	BYTE	3			Write Multiple Coils
		Channel 1[1]	%QB11	BYTE	3			Write Multiple Coils
		Channel 2	%QW6	ARRAY [0..7] OF WORD	Not updated			Write Multiple Registers
		Channel 2[0]	%QW6	WORD	716			0x0000
		Channel 2[1]	%QW7	WORD	756			0x0001
		Channel 2[2]	%QW8	WORD	0			0x0002
		Channel 2[3]	%QW9	WORD	0			0x0003
		Channel 2[4]	%QW10	WORD	0			0x0004
		Channel 2[5]	%QW11	WORD	0			0x0005
		Channel 2[6]	%QW12	WORD	0			0x0006
		Channel 2[7]	%QW13	WORD	0			0x0007
		Channel 3	%QW14	ARRAY [0..3] OF WORD	Not updated			Write Multiple Registers
		Channel 3[0]	%QW14	WORD	0			0x0008
		Channel 3[1]	%QW15	WORD	0			0x0009
		Channel 3[2]	%QW16	WORD	913			0x000A
		Channel 3[3]	%QW17	WORD	781			0x000B

6.4 Modbus RTU Slave

Topology diagram

Modbus RTU Slave Communication topology diagram

Note: The red part of the figure is this case communication topology map

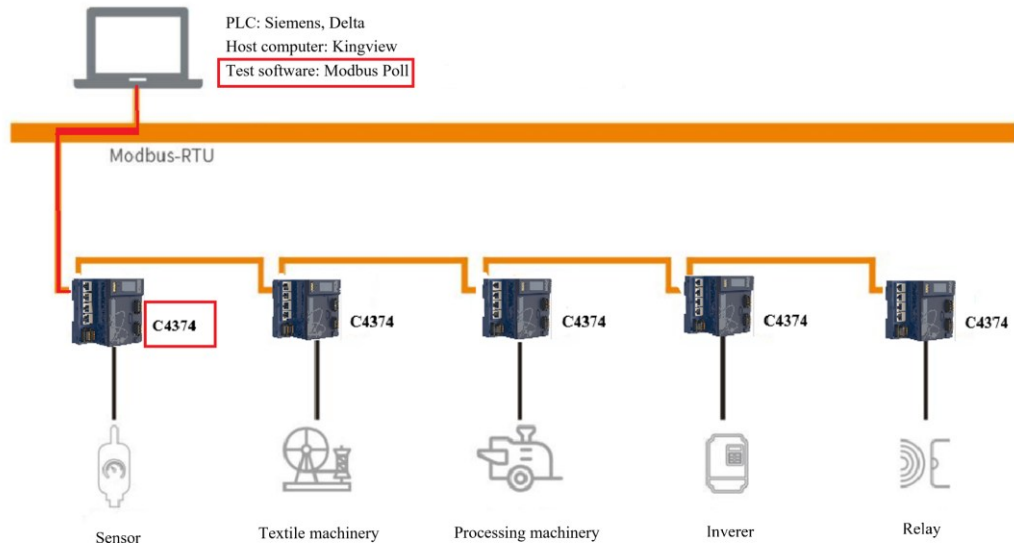

Hardware configuration: C4374+CT-121F+CT-222F+CT-3168+CT-4154

First, open the Codesys software and click New Project.

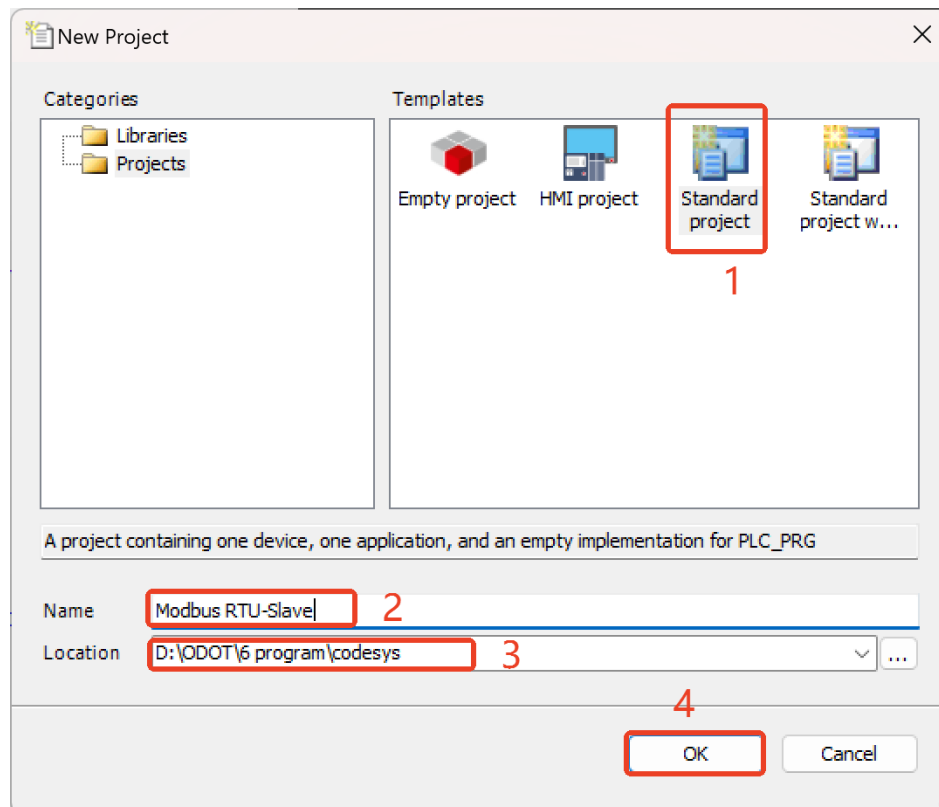

Then select the C4374 device, if can't find the device, refer to the installation device

description file, and click OK.

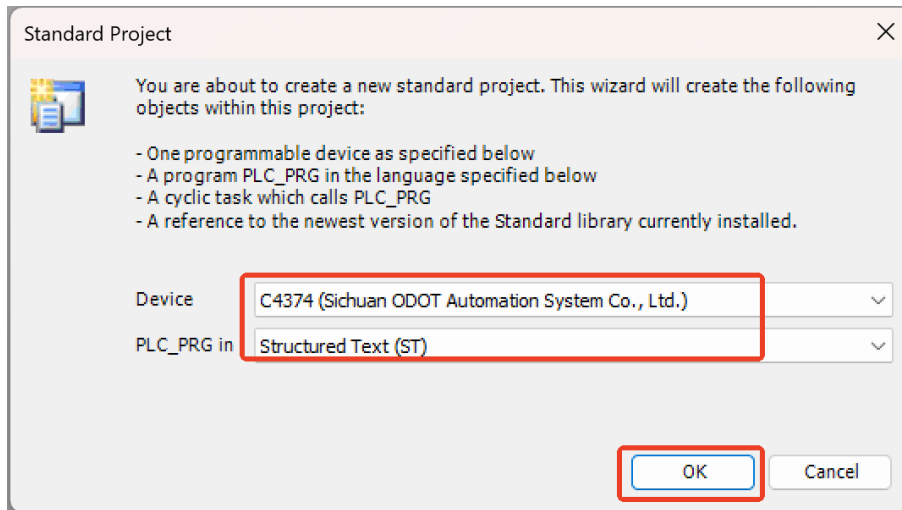

After the project is created, right-click C4374 and select Add Device.

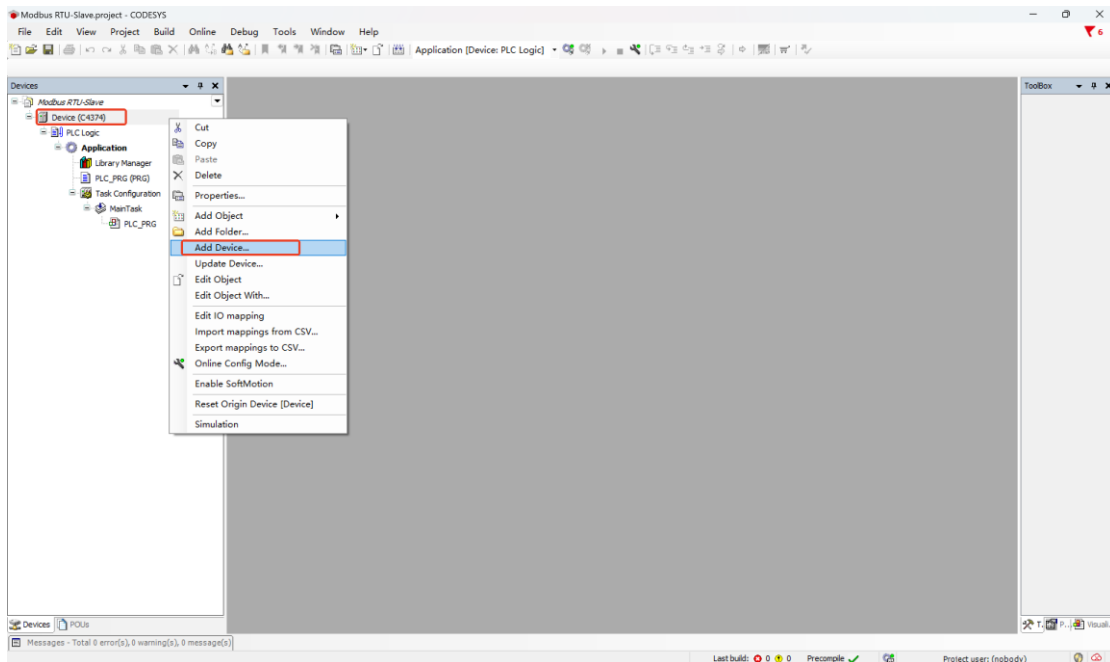

Find "IO Modules" in the pop-up window, select it, click Add Device, and don't need to close this page after adding.

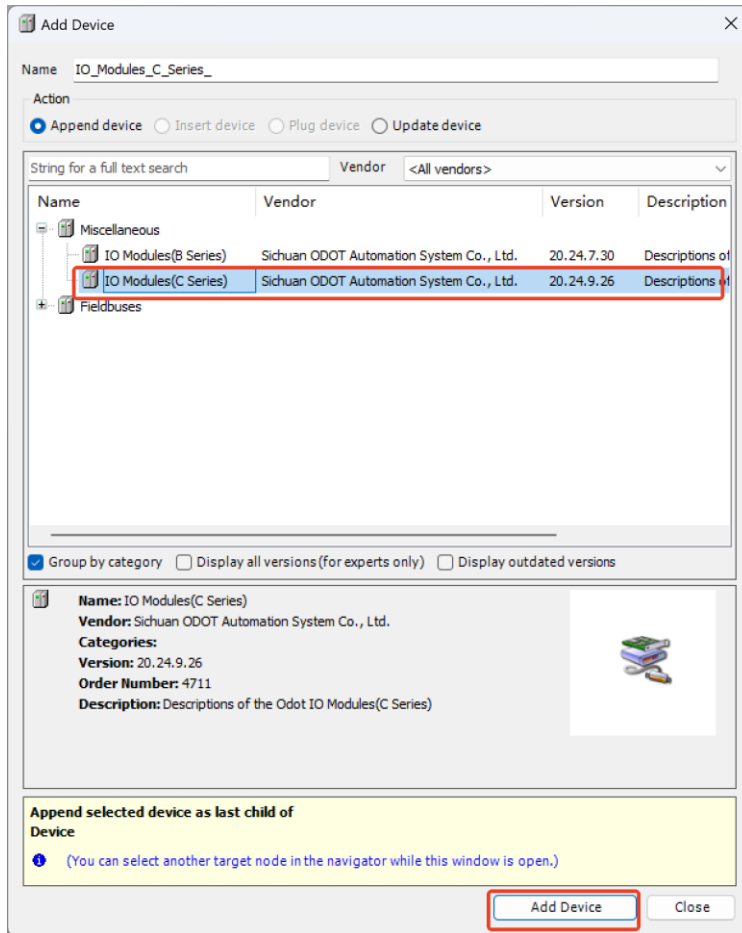

Select the "empty" slot, and insert the corresponding module according to the hardware configuration, and the functions of the module are listed in the selection table.

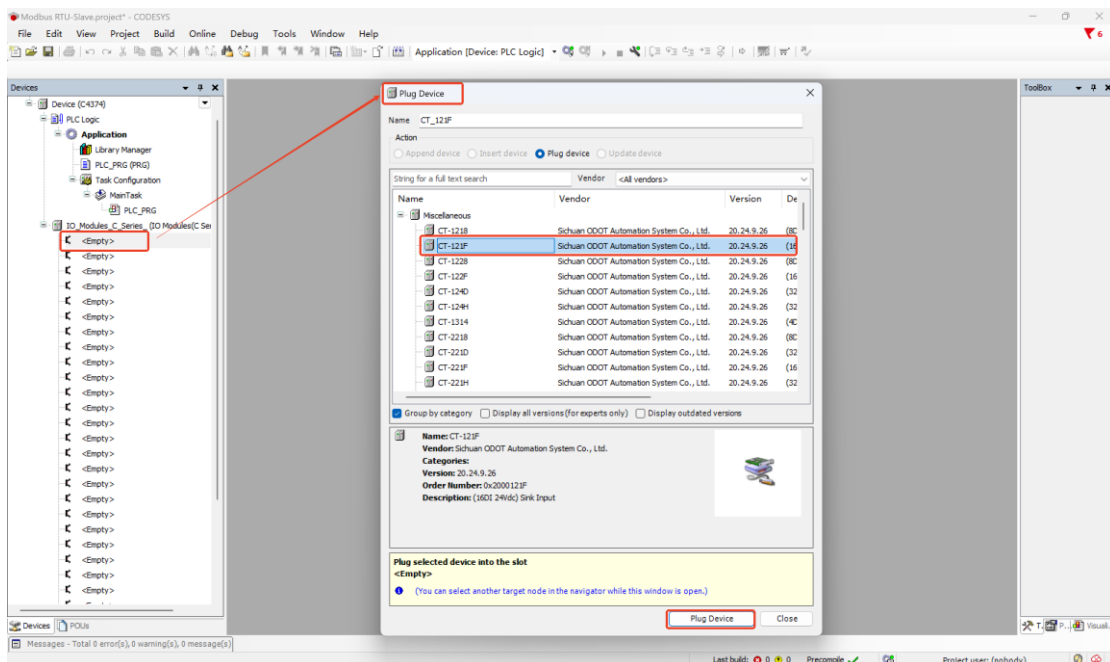

Double-click the module and select I/O Mapping to view the corresponding I/O address and set the mapping relationship.

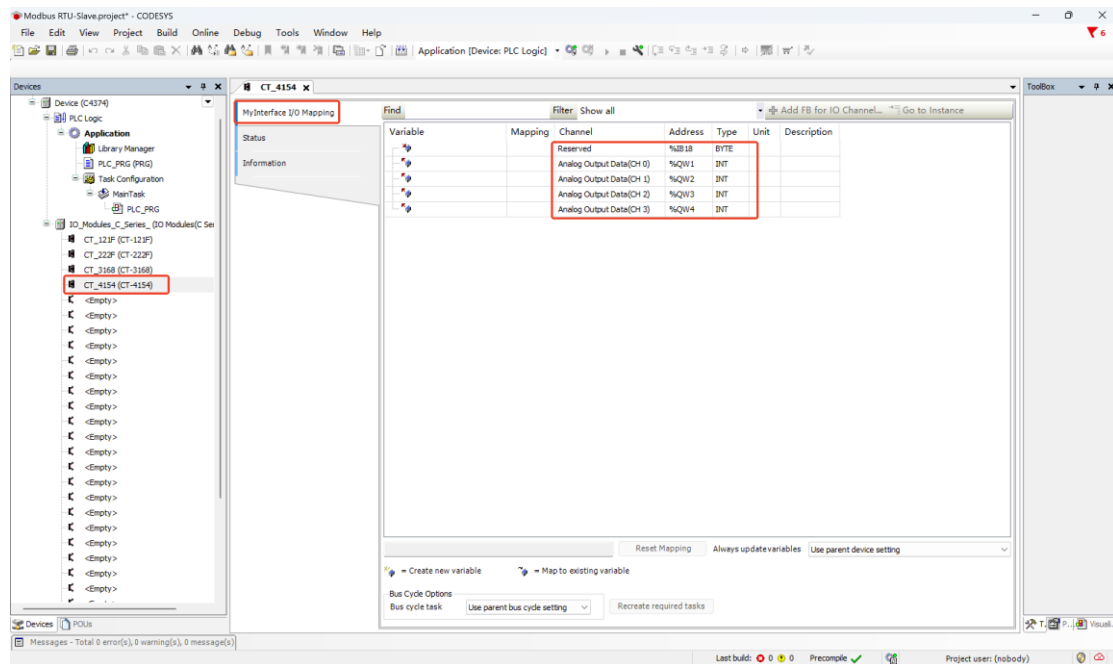

Set the Always Update variable to enable 1 (or use the bus cycle task if not used in any task).

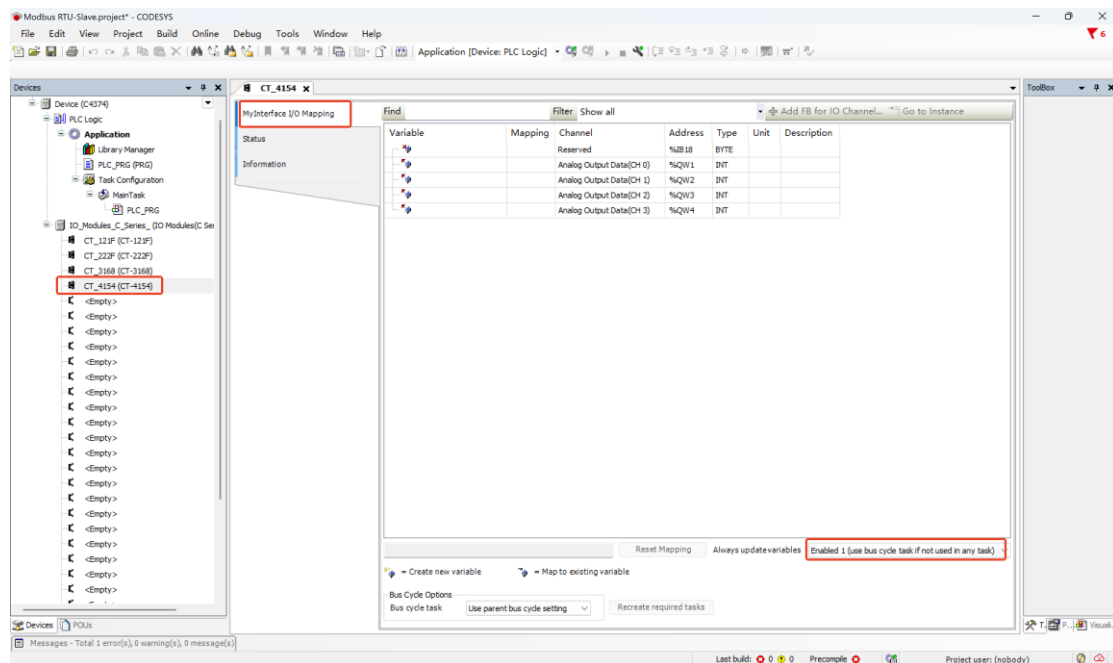

Right-click C4374, select Add Device, select "Modbus—Modbus Serial Port—Modbus COM", and click Add Device to close the "Add Device" window.

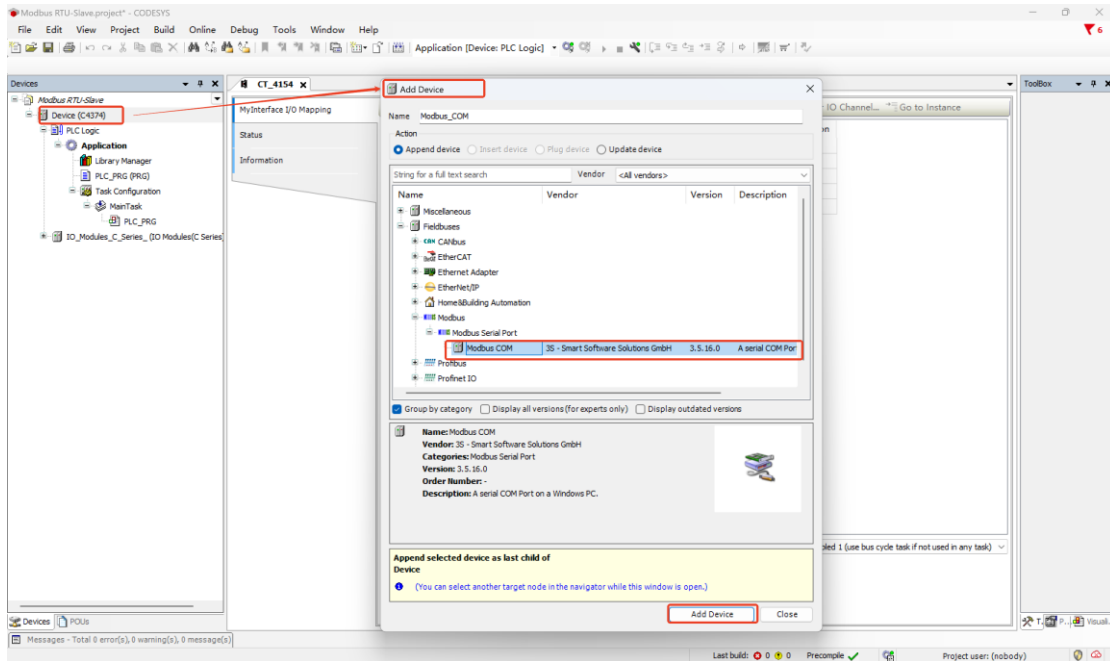

Select Modbus COM, in the Add Device window select “Modbus serial device—Modbus Serial Device”, click Add device.

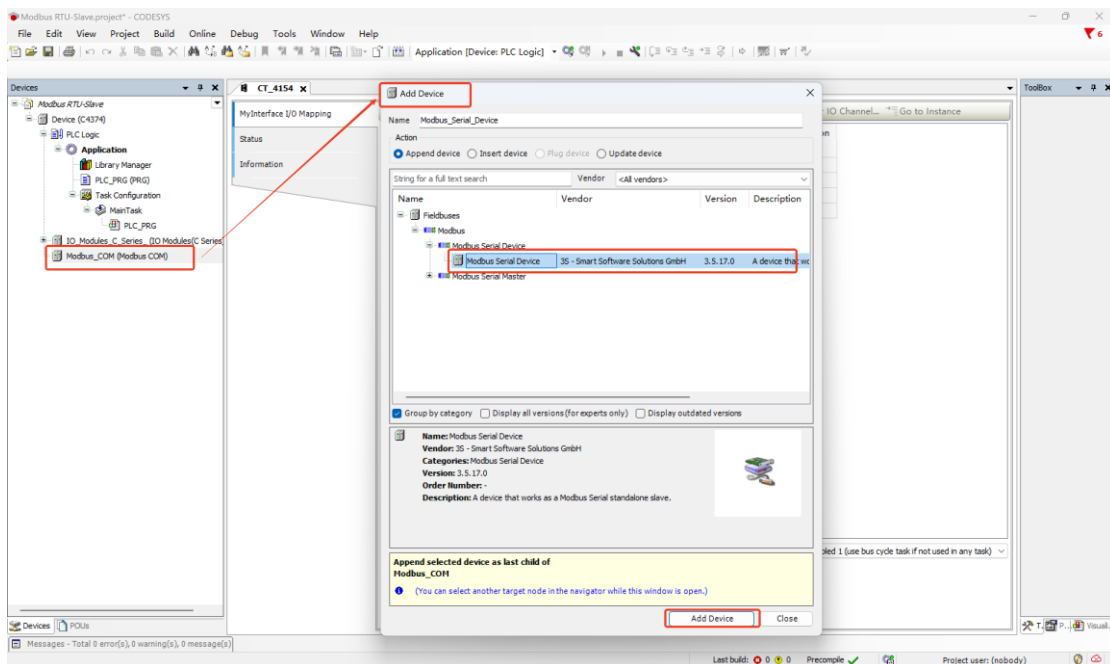

Next, the parameters of the slave and the third-party master are set up, which is simulated using the Modbus Poll software. Double-click Modbus COM, select Universal-Serial Port Configuration, set the baud rate to 9600, parity: None, data bit: 8, stop bit: 1.

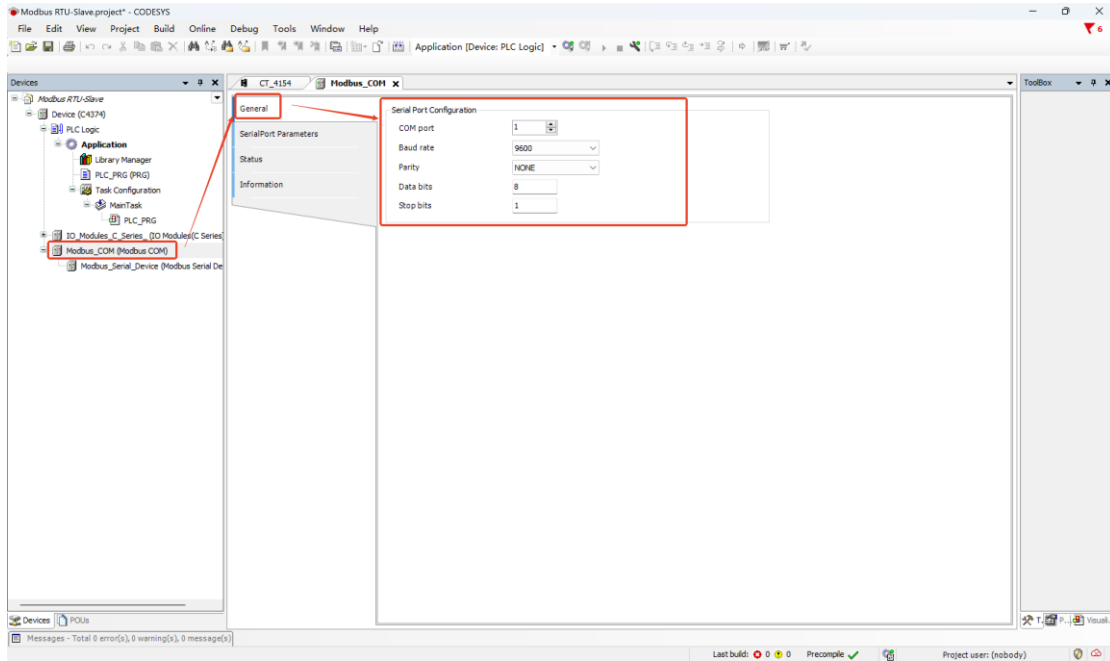

Double-click "Modbus Serial Device", select "General" on the main interface on the right, set the unit ID in the configuration parameters, keep the register length and input register length, and modify the start address and other parameters.

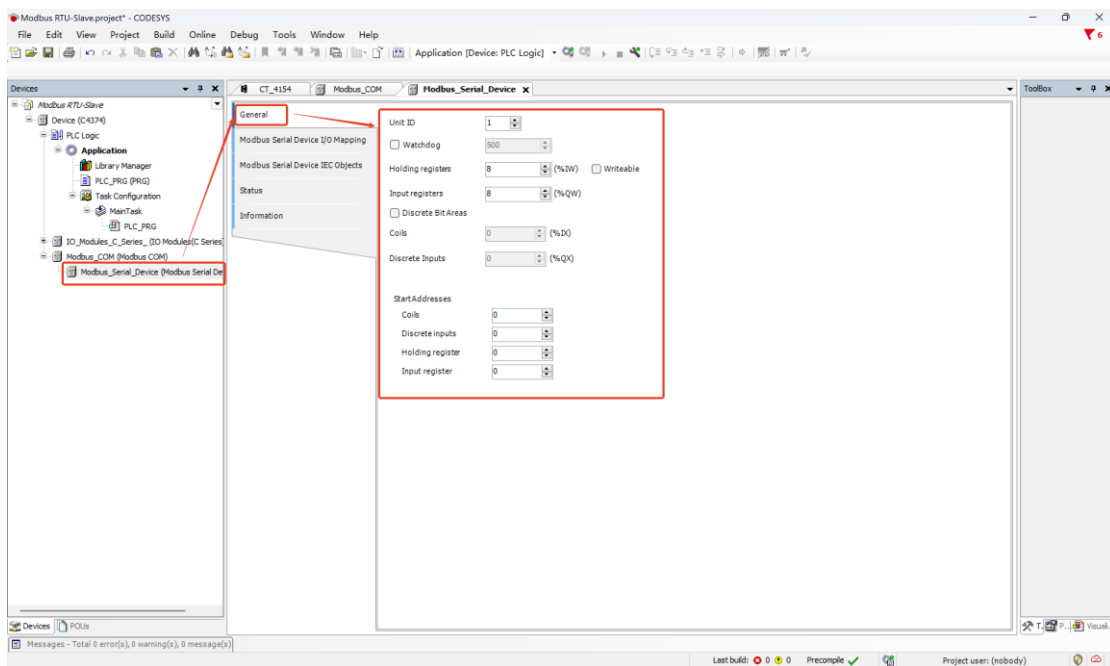

After the configuration is complete, click Modbus Serial Device I/O Mapping to view the mapped address of the newly established slave device on the C4374 and set the Always Update variable to Enable 1.

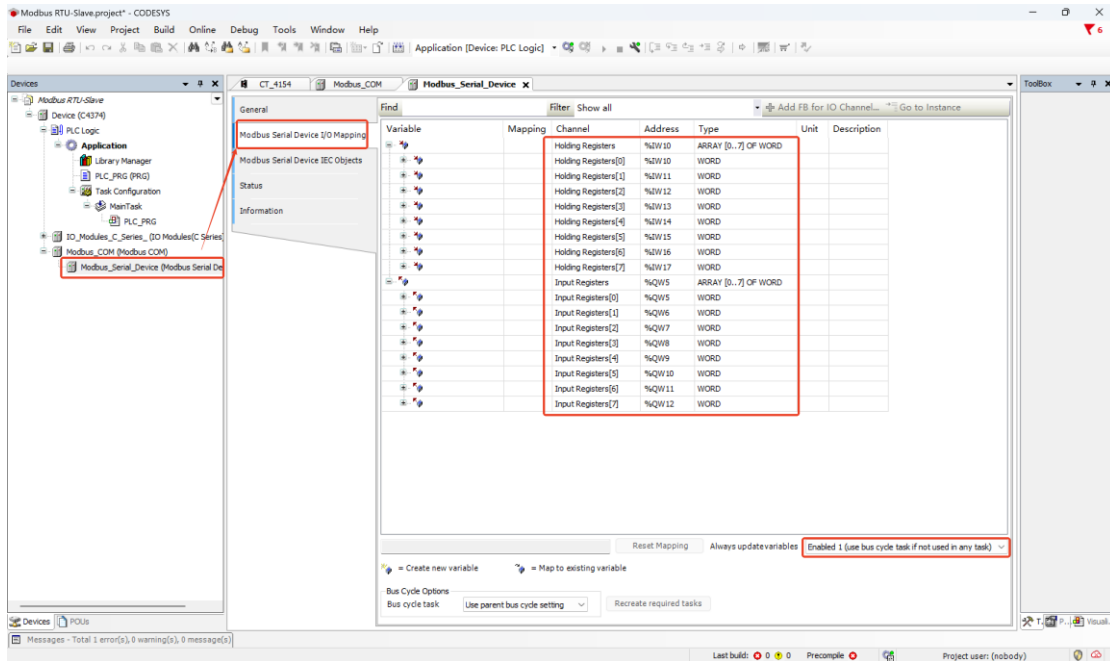

Next, open the third-party master simulation software "Modbus Poll", “Ctrl+N” create two Mbpoll windows, right-click and in the blank space of the two windows select “Read/Write Definition”, the "Slave ID" of the first window is set to 1, select “Function” as “03 Read Holding Registers (4x)”, “Quantity” set to hold register length in Codesys; The second window "Slave ID" is set to 1, select “Function” as “04 Read Input Registers (3x)”, “Quantity” set to the length of the input registers in Codesys:

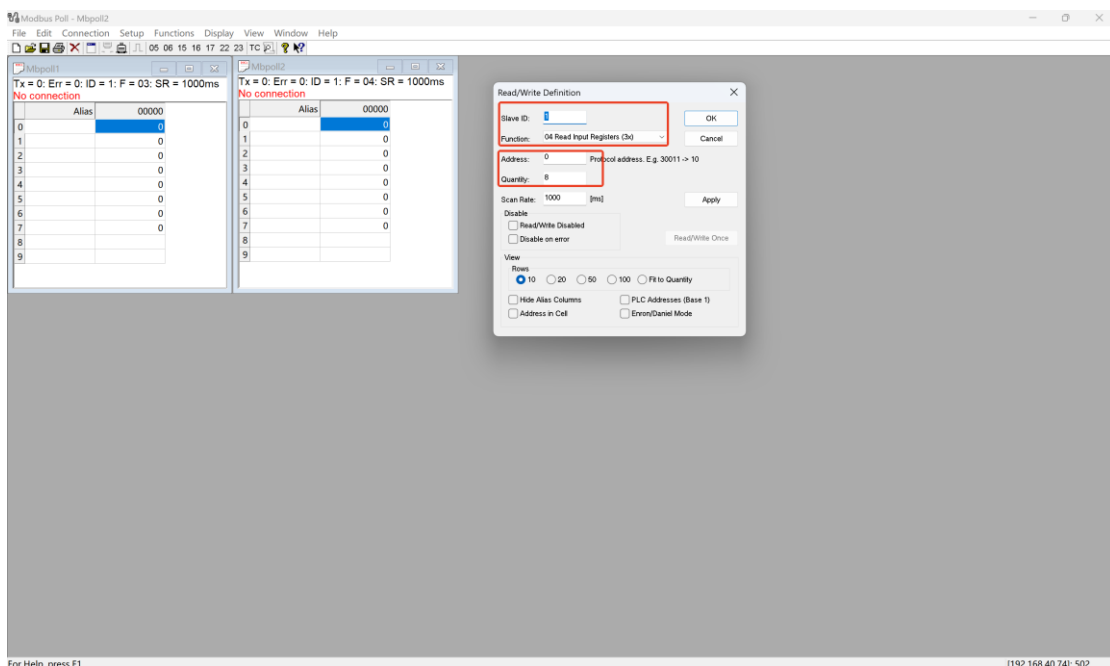

After completion, return to the Codesys interface, download and log in to the C4374 device again, at this time, the bus is not running, and the error will disappear after connecting to the Modbus RTU master.

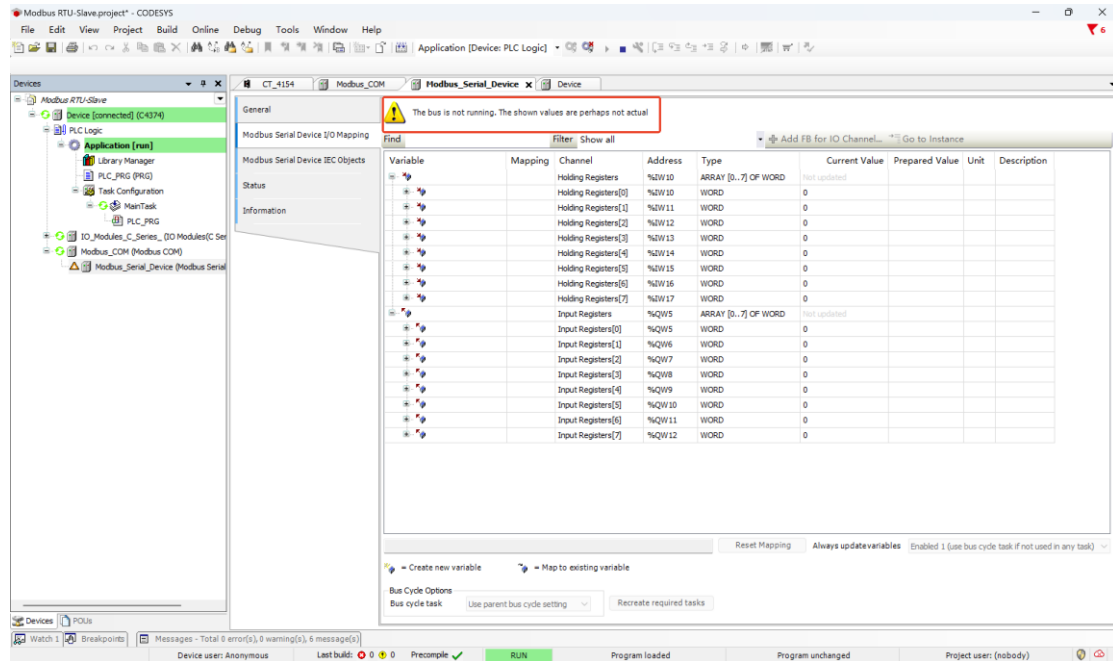

Go back to the "Modbus Poll" software, press "F3" to connect, set the type of "Connection Setup" to "Serial Port" on the pop-up page, select the correct COM port, set the baud rate and other communication parameters, and keep them the same as in the Codesys software.

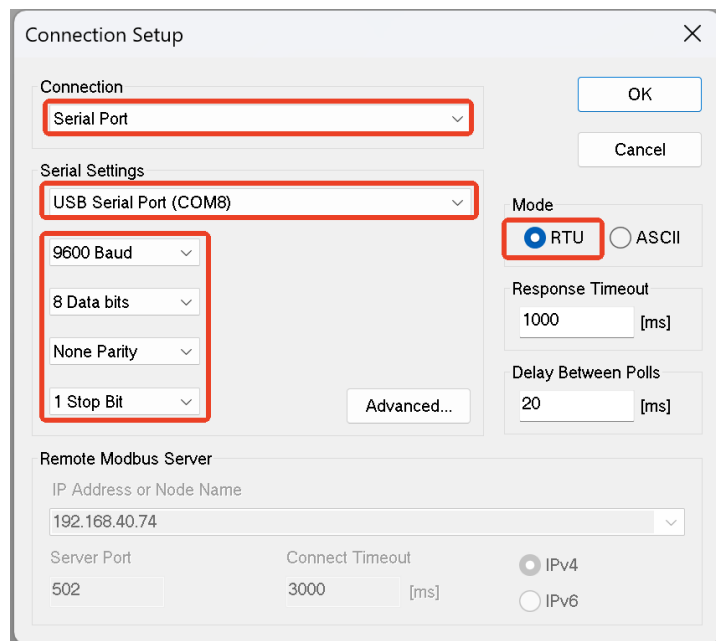

Back in the Codesys software, all the devices are working properly.

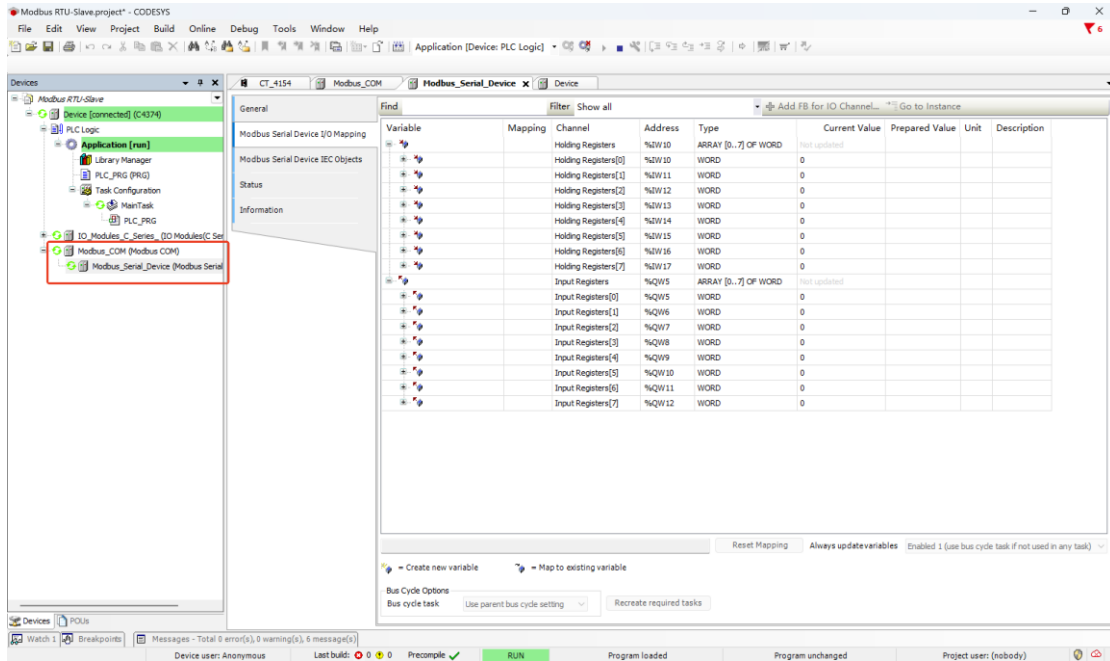

Let's verify the communication, the first step, in “Modbus Serial Device I/O Mapping” double-click to modify the preparatory value of the input register 5134, “Ctrl+F7” to write.

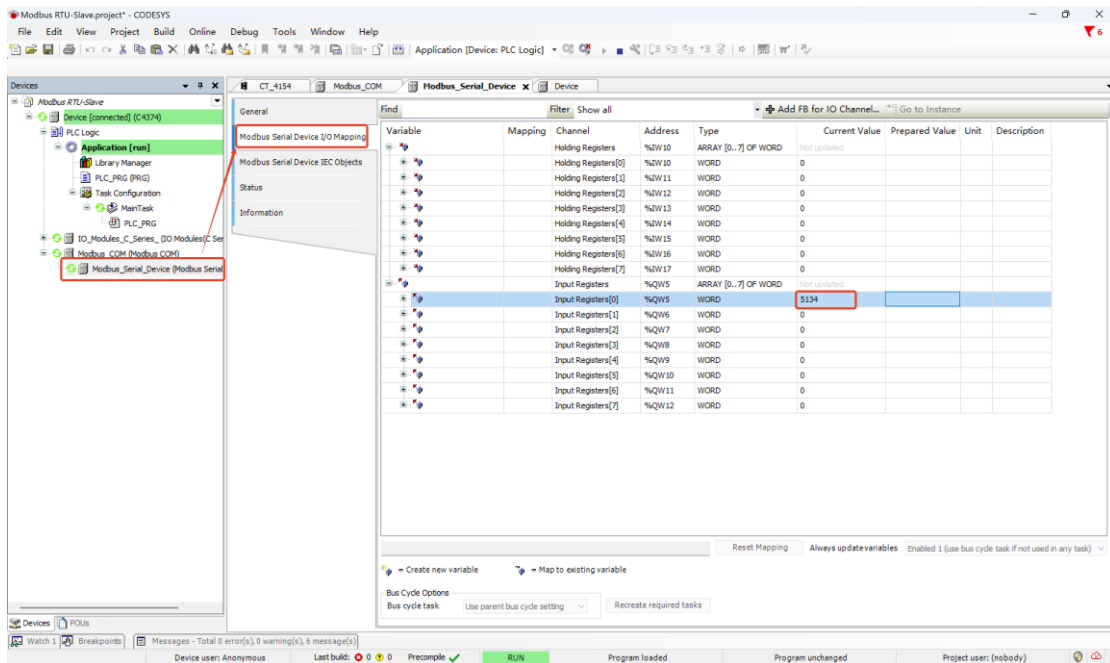

Back to the "Modbus Poll" software, it can see that the value of Mbpoll2 has been successfully modified. Double-click the first line of Mbpoll1 to change the value to 871.

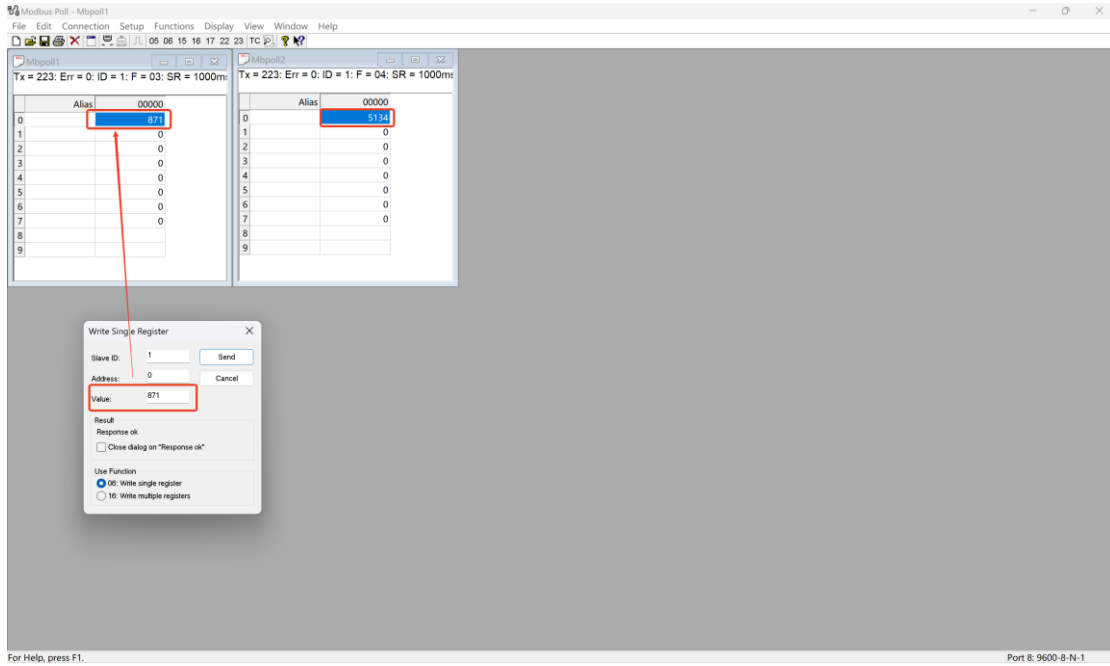

Back to the Codesys software, it was found that the value of the first WORD of the hold register was modified to 871, indicating that the communication was normal.

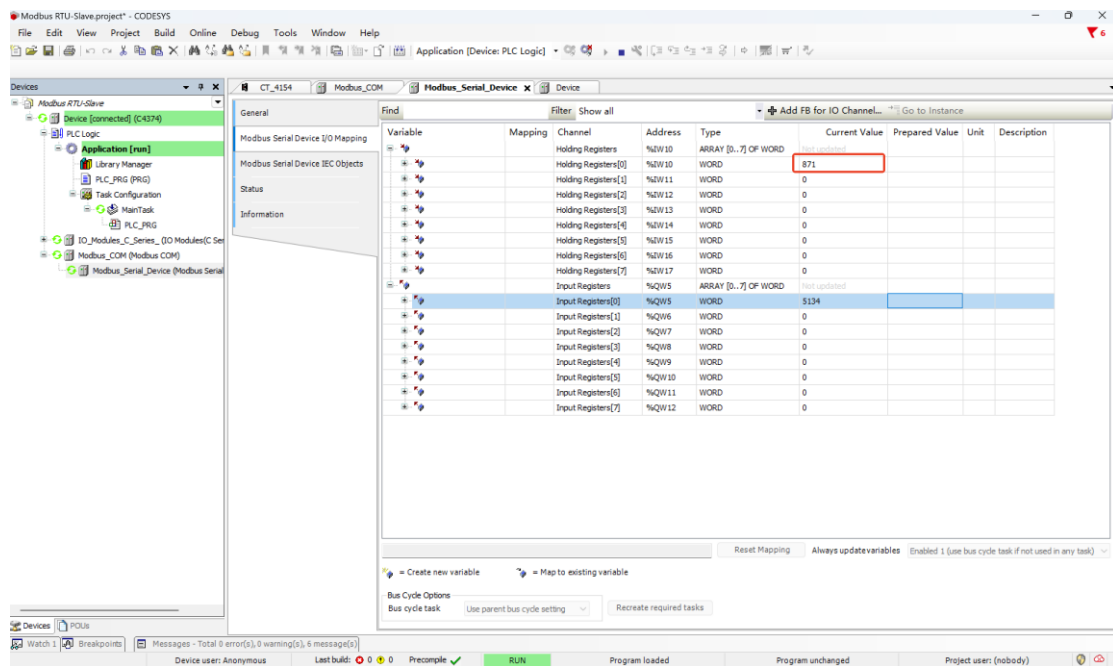

6.5 EtherCAT Master

Topology diagram

C4374 EtherCAT Master Communication topology diagram

Note: The red part of the figure is this case communication topology map

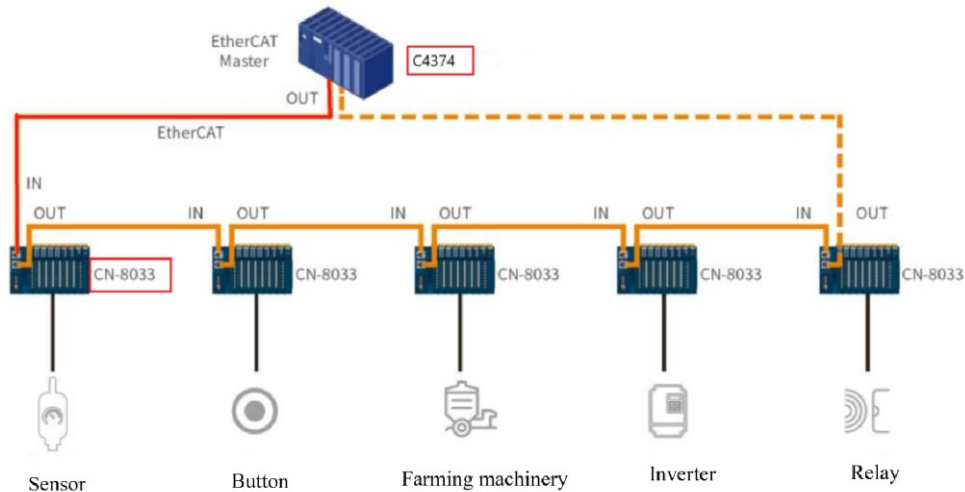

Hardware configuration: C4374+CT-121F+CT-222F+CT-3168+CT-4154+CT-5801;

CN-8033+CT-121F+CT-222F+CT-4238+CT-4154; Note: EtherCAT communication strictly distinguishes between input and output, and the interface must not be connected incorrectly, otherwise the module communication may be abnormal.

First, open Codesys, click New Project, set the project name and file location, and click OK.

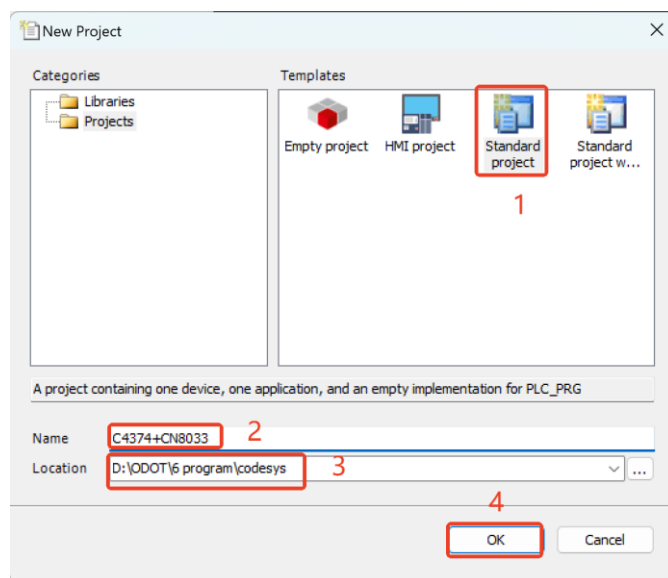

Then select the C4374 device, if can't find the device, refer to the installation device

description file, and click OK.

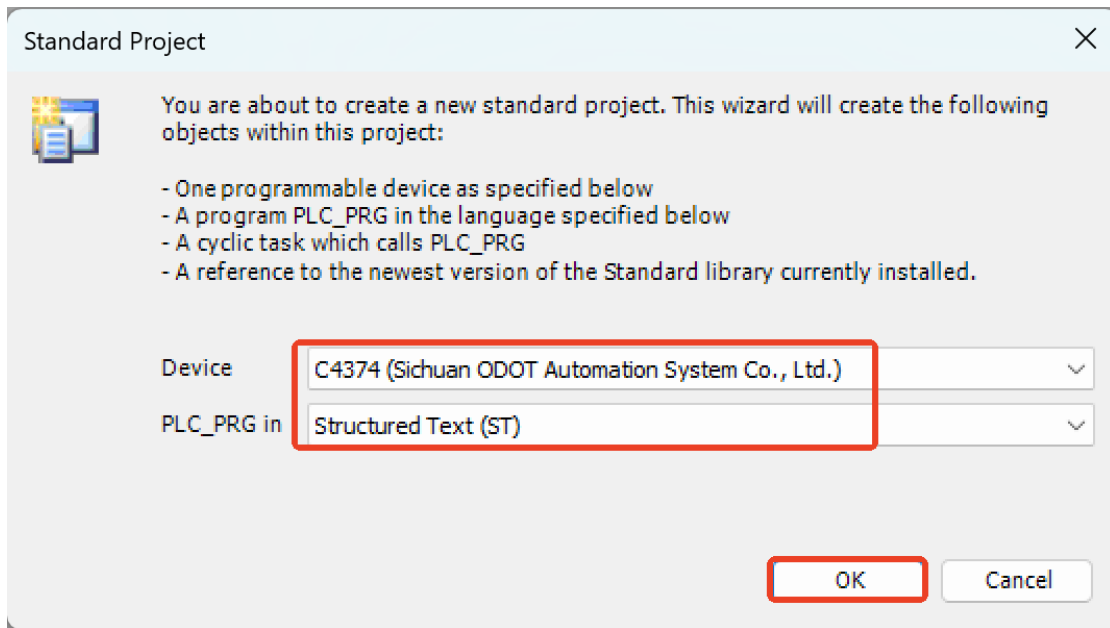

After the project is created, right-click C4374 and select Add Device.

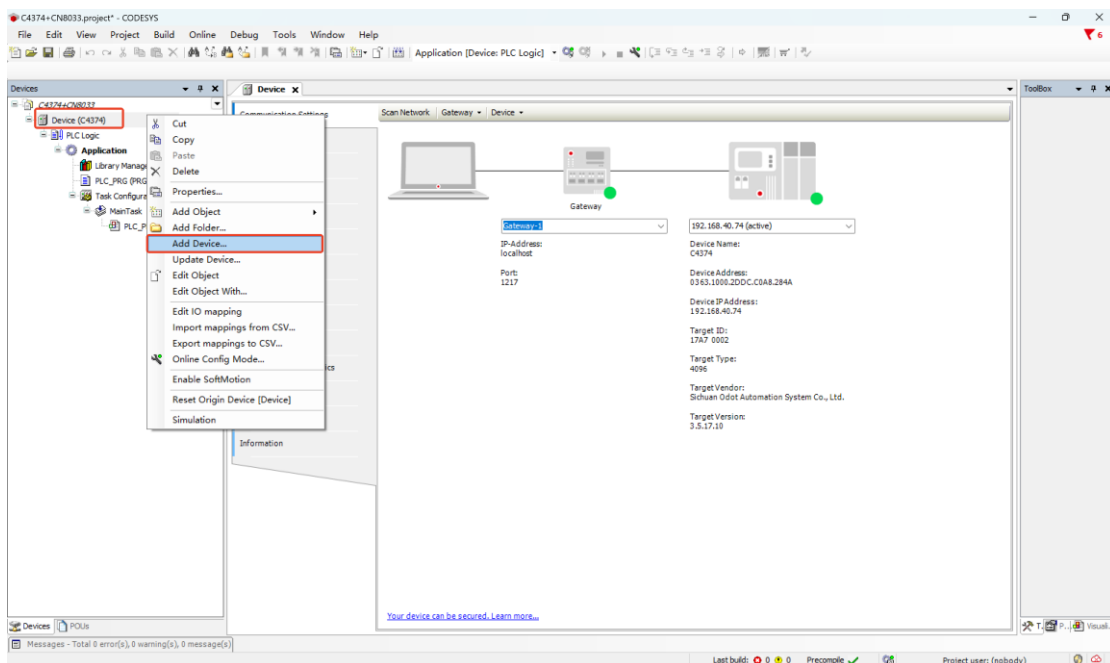

Find "IO Modules" in the pop-up window, select it, click Add Device, and don't need to close this page after adding.

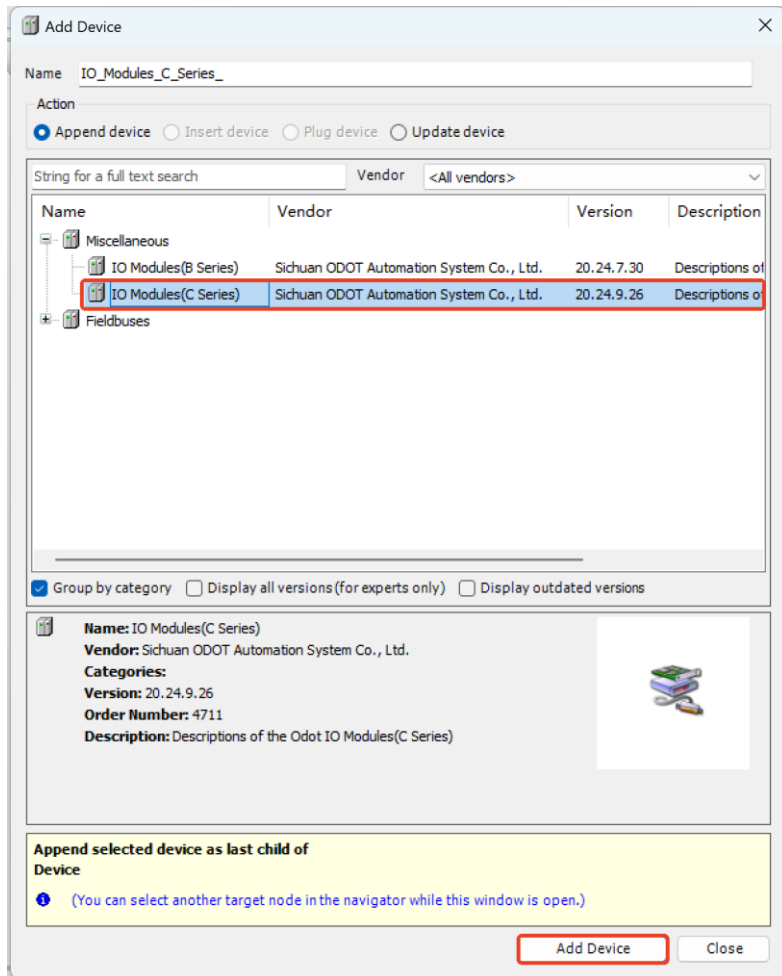

Select the "empty" slot, and insert the corresponding module according to the hardware configuration, and the functions of the module are listed in the selection table.

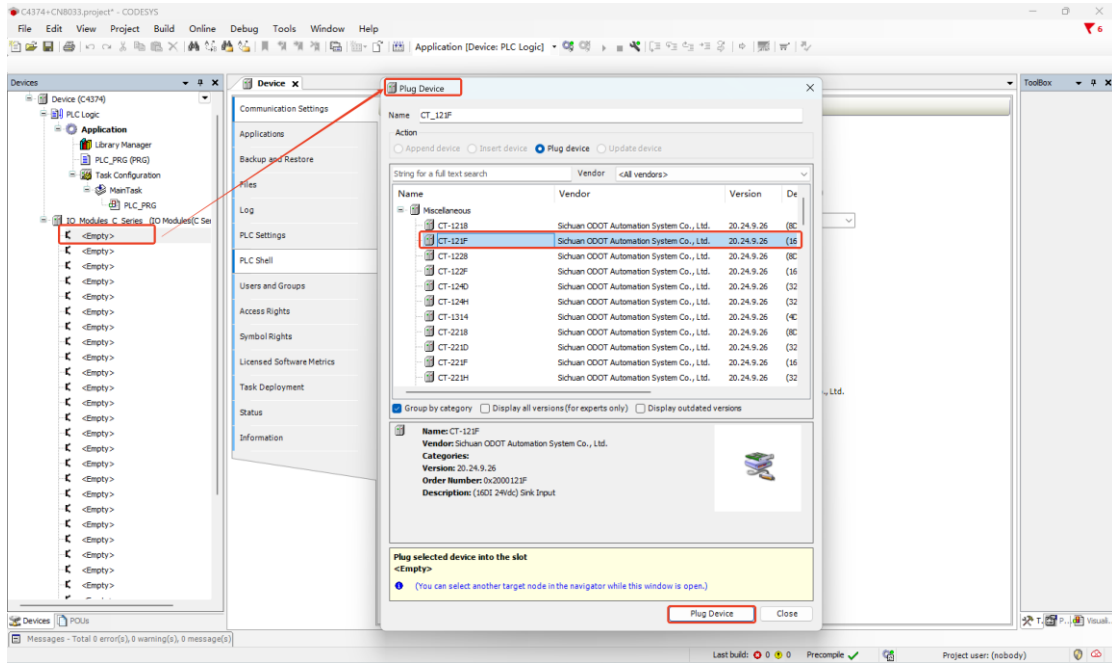

Double-click the module and select I/O Mapping to view the corresponding I/O address, set the mapping relationship, and set the Always Update variable to Enable 1.

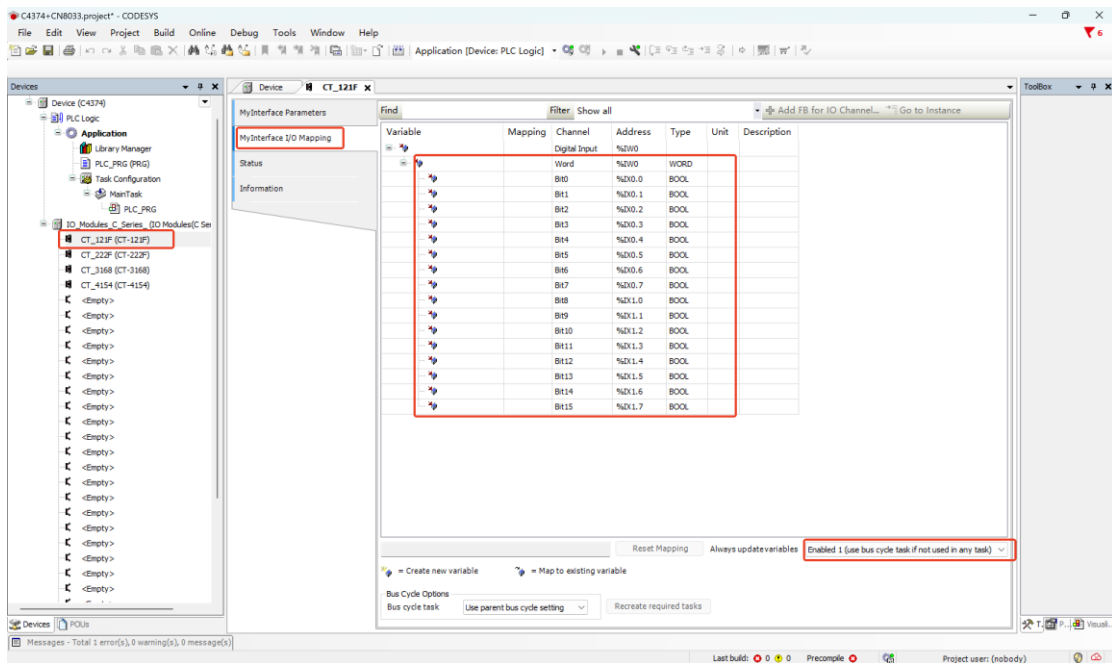

Right-click on C4374, select Add Device, select EtherCAT - Master - EtherCAT Master, and click Add Device.

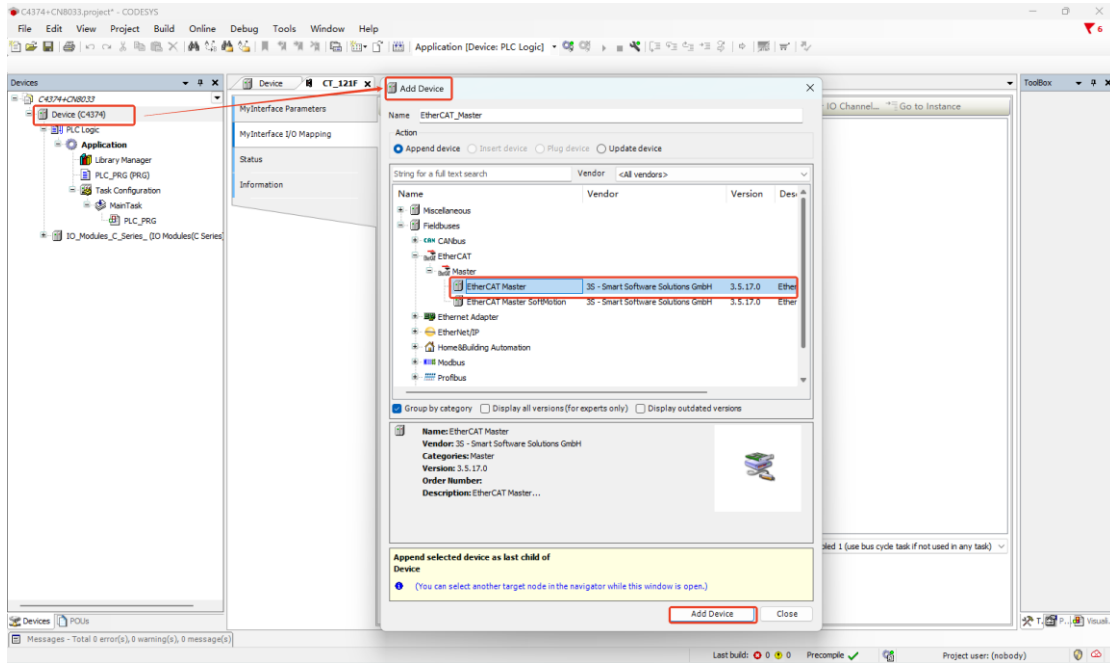

Double-click Device (C4374), select Communication Settings, enter the IP address of the C4374 module (the IP address of the module can be viewed on the LCD screen), and press Enter to activate the device.

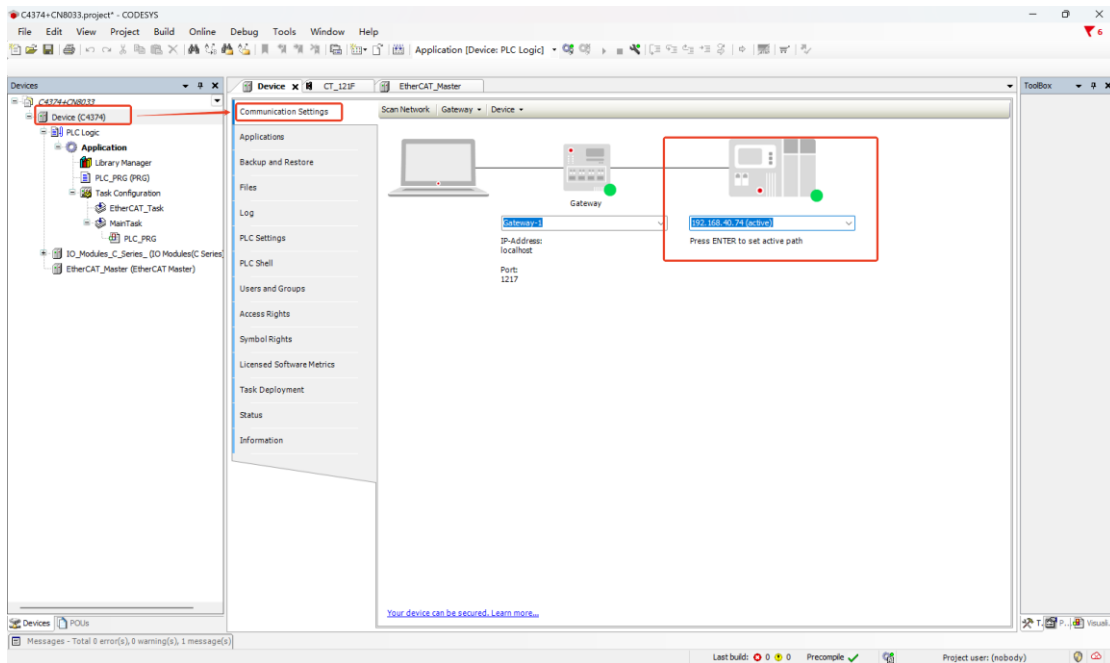

Double-click EtherCAT Master, select General, and in EtherCAT NIC settings, click Browse, select the corresponding network adapter, and click OK.

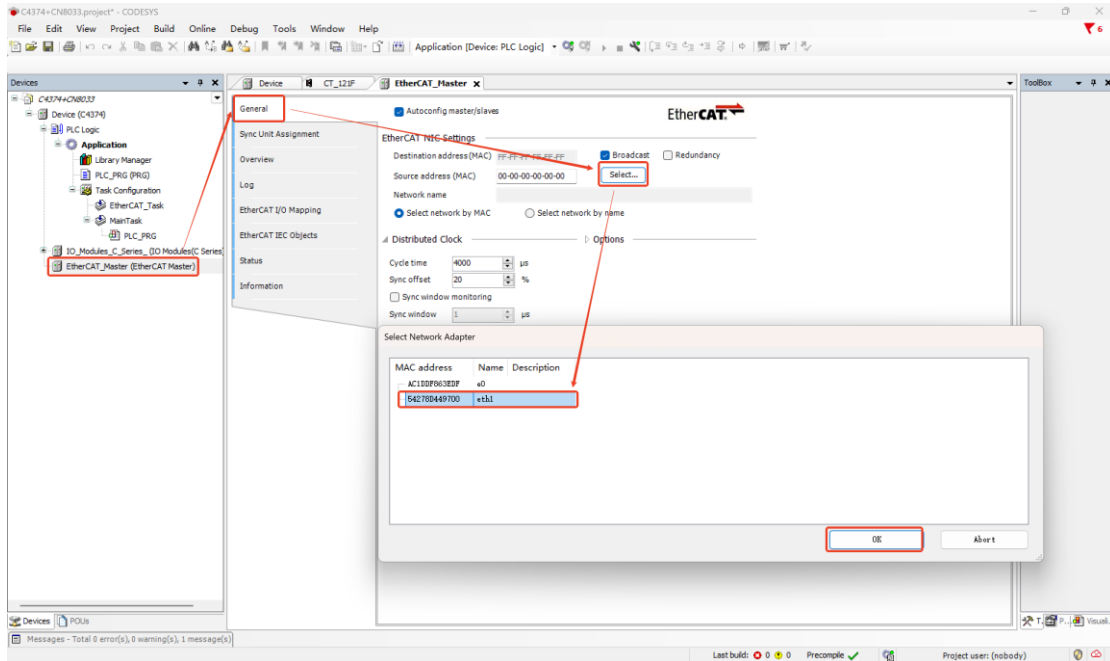

Right-click on the EtherCAT Master, click on the scan module, and the pop-up window will display "Scan device not available: stack unavailable!" Please log in first".

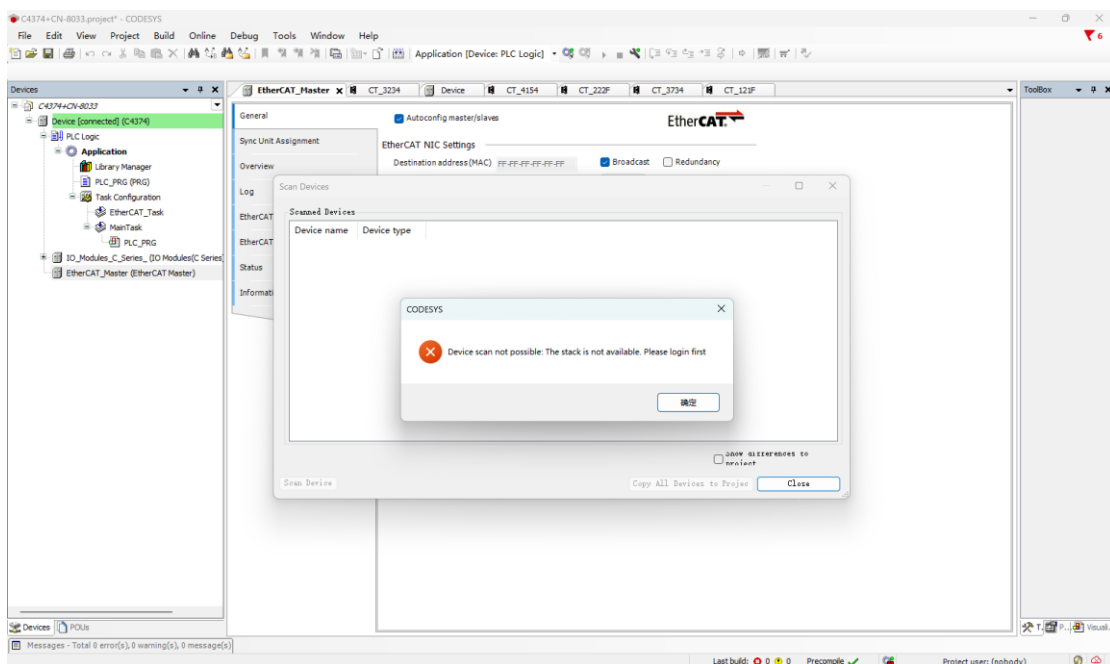

Close the window, select the PLC Device, click "Compile", compile without error, click "Login to", click Yes, and then click "Start".

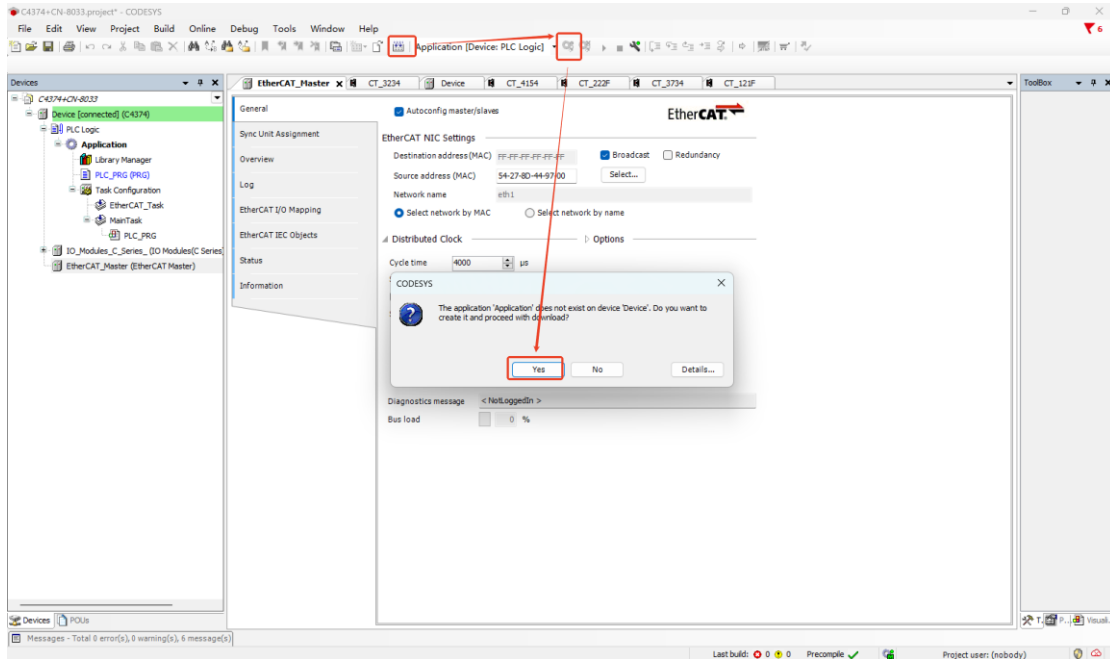

Right-click EtherCAT Master, click Scan Devices, it can view the IO modules mounted on CN-8033 and its back, and click Copy All Devices to the project.

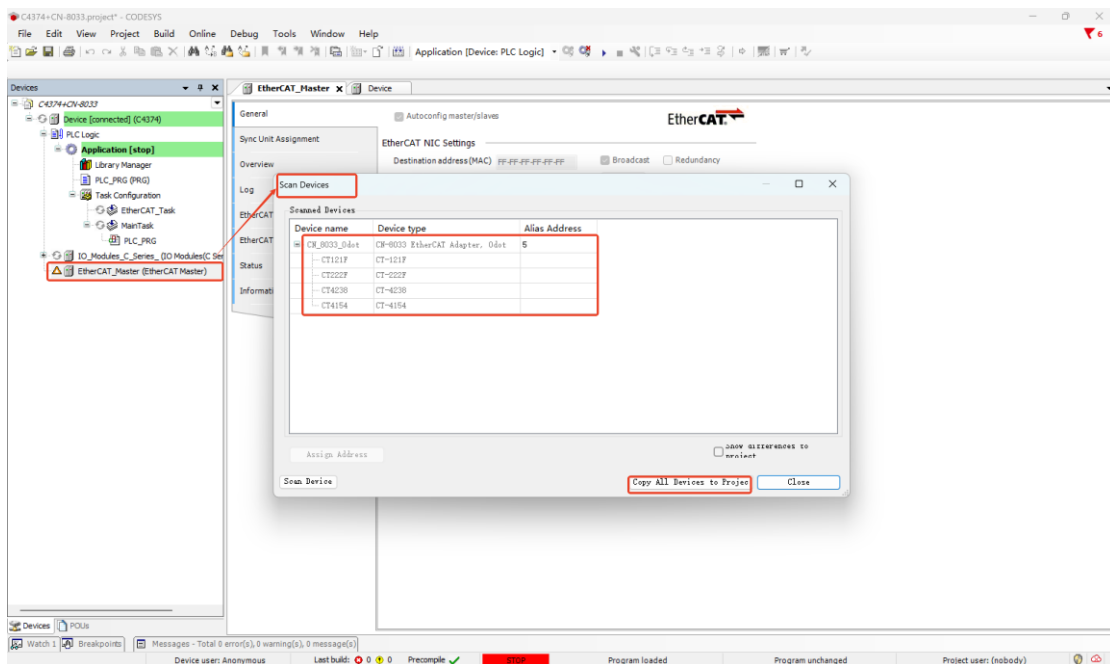

If the pop-up window shows that the device is not located in the device library, click Tools - Install Device Repository to install the device description file of CN-8033.

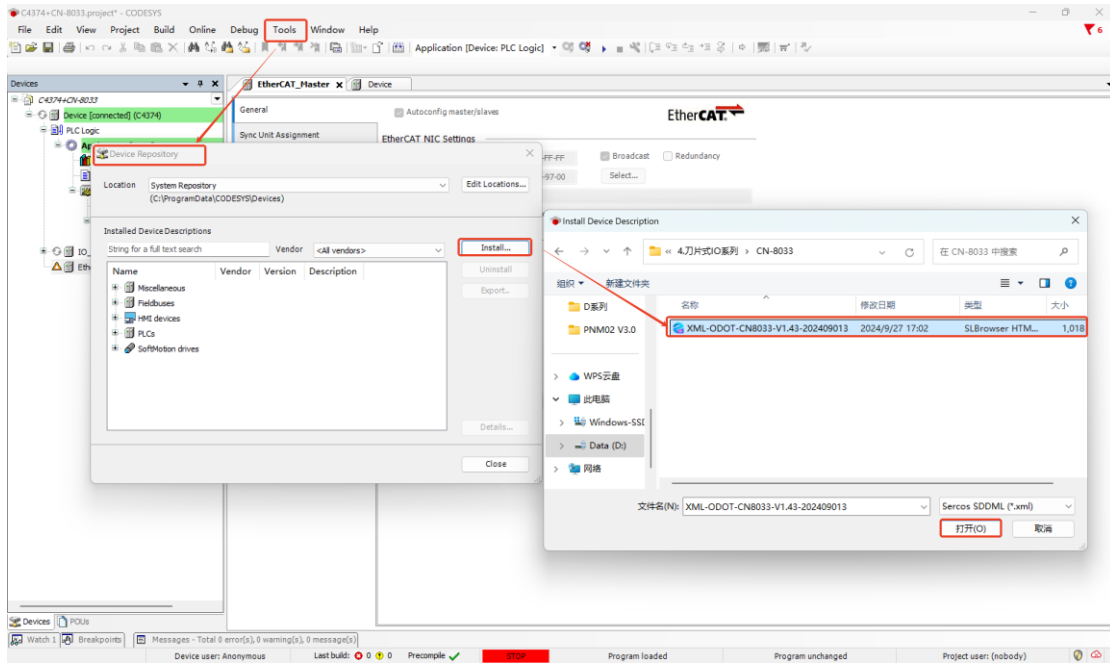

The factory alias address of the CN-8033 module is 0, it can set the alias address through the module hardware dial code, or set it in the Codesys software, select the scanned CN-8033, write 2 in the alias address, click Assign Address, click Copy to Project.

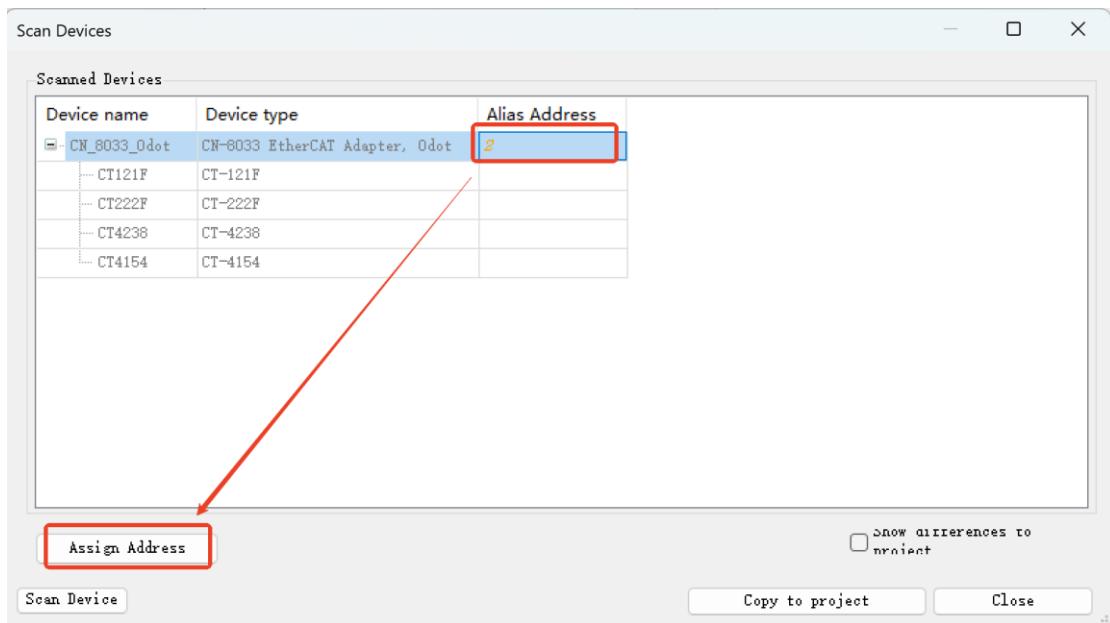

Log out of the PLC and select I/O Module --Module I/O Mapping to modify the address mapping relationship and set the Always Update variable to enable 1.

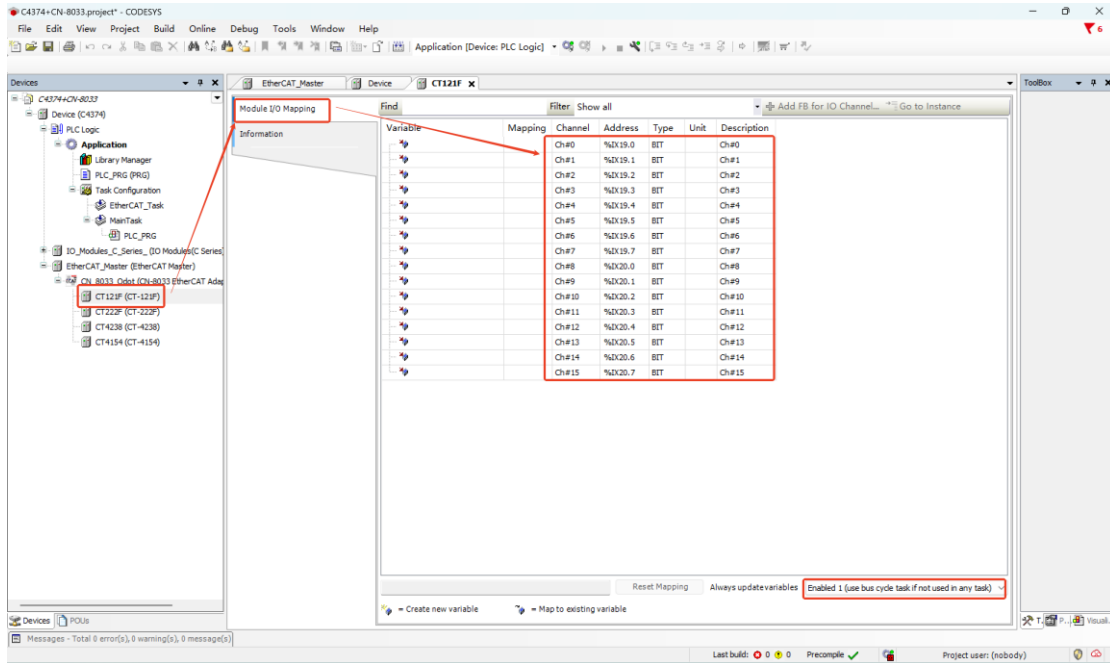

Select the module, click Module I/O mapping, it can monitor the module status online, select CT-222F, modify the value on the right side of the preparatory value, and click "Debug - Write Value" to write the value to CT-222F.

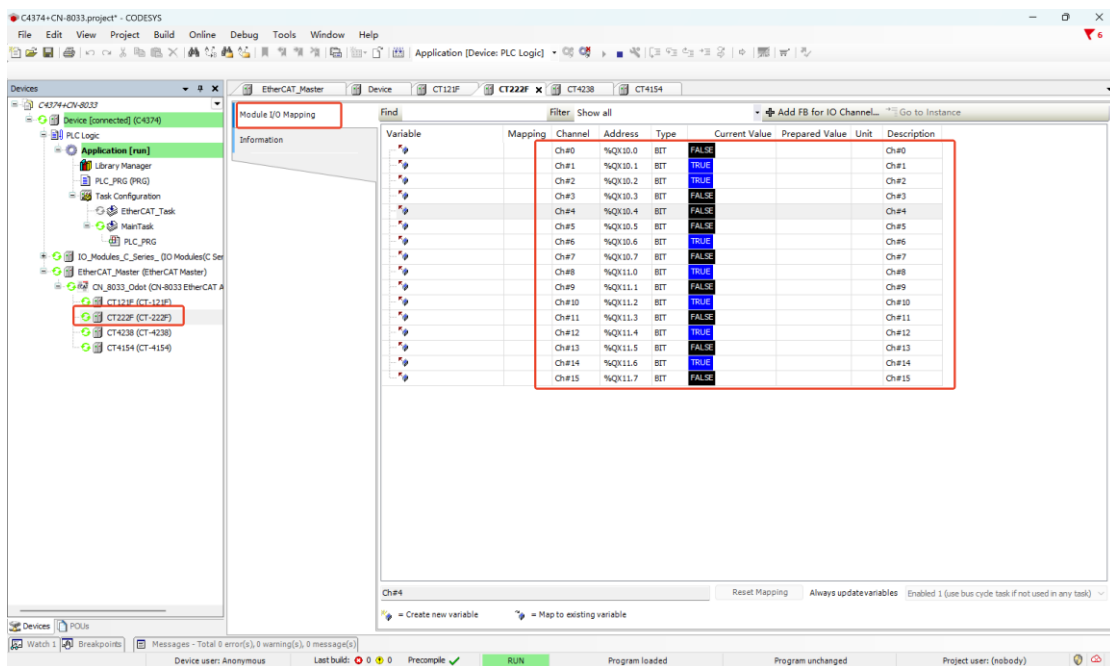

6.6 CANOpen Master

Topology diagram

C4374 CANopen Master communication topology diagram

Note: The red part of the figure is this case communication topology map

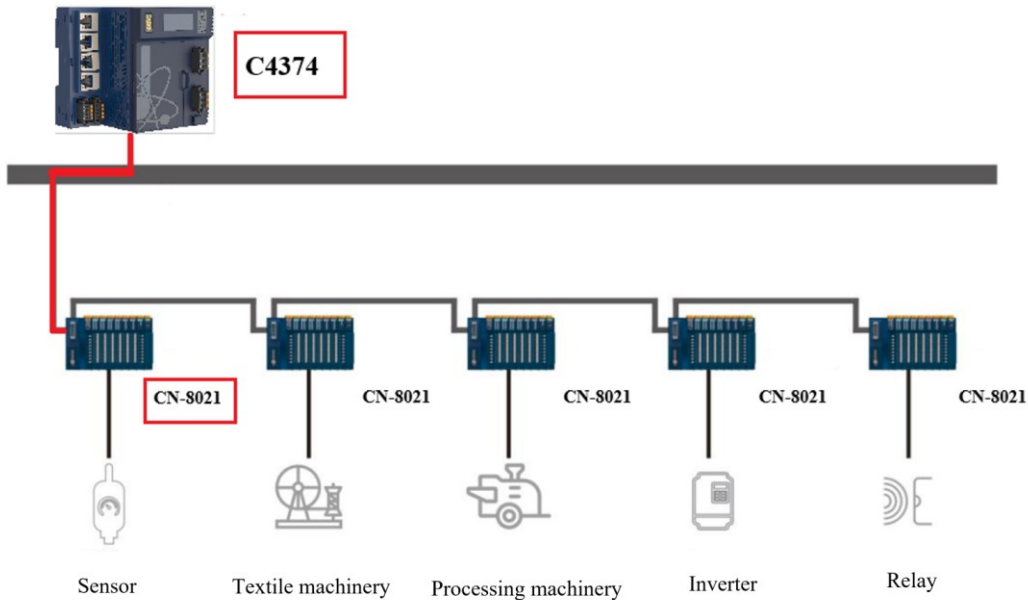

Hardware configuration: C4374+CT-121F+CT-222F+CT-4238+CT-4154; CN-8021+CT-121F+CT-222F+CT-3168+CT-4154;

First, open Codesys, click New Project, set the project name and file location, and click OK.

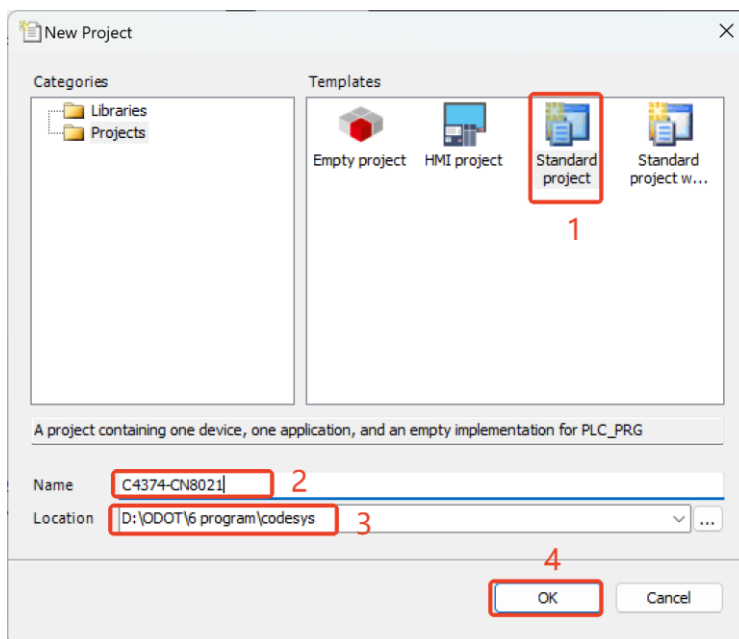

Then select the C4374 device, if can't find the device, refer to the installation device description file, and click OK.

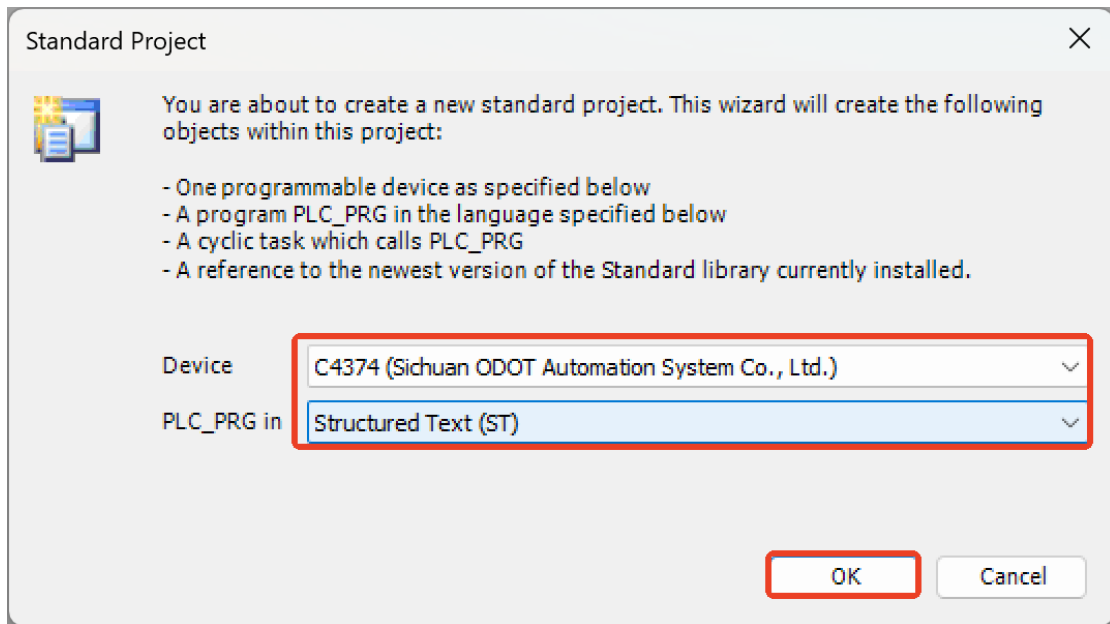

After the project is created, right-click C4374 and select Add Device.

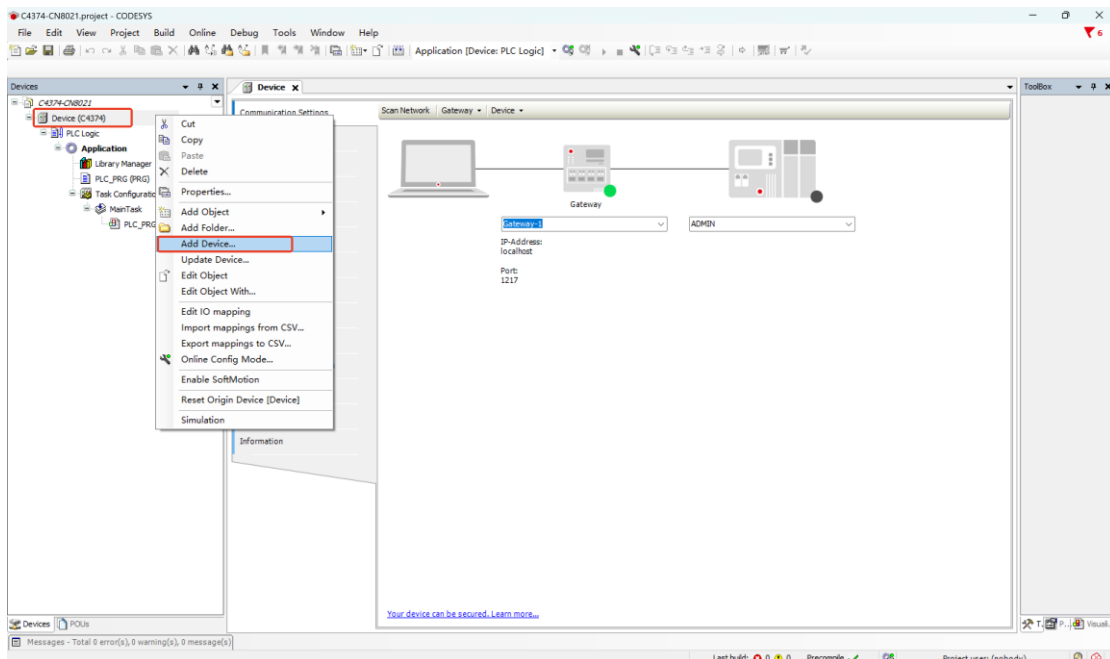

Find "IO Modules" in the pop-up window, select it, click Add Device, and don't need to close this page after adding.

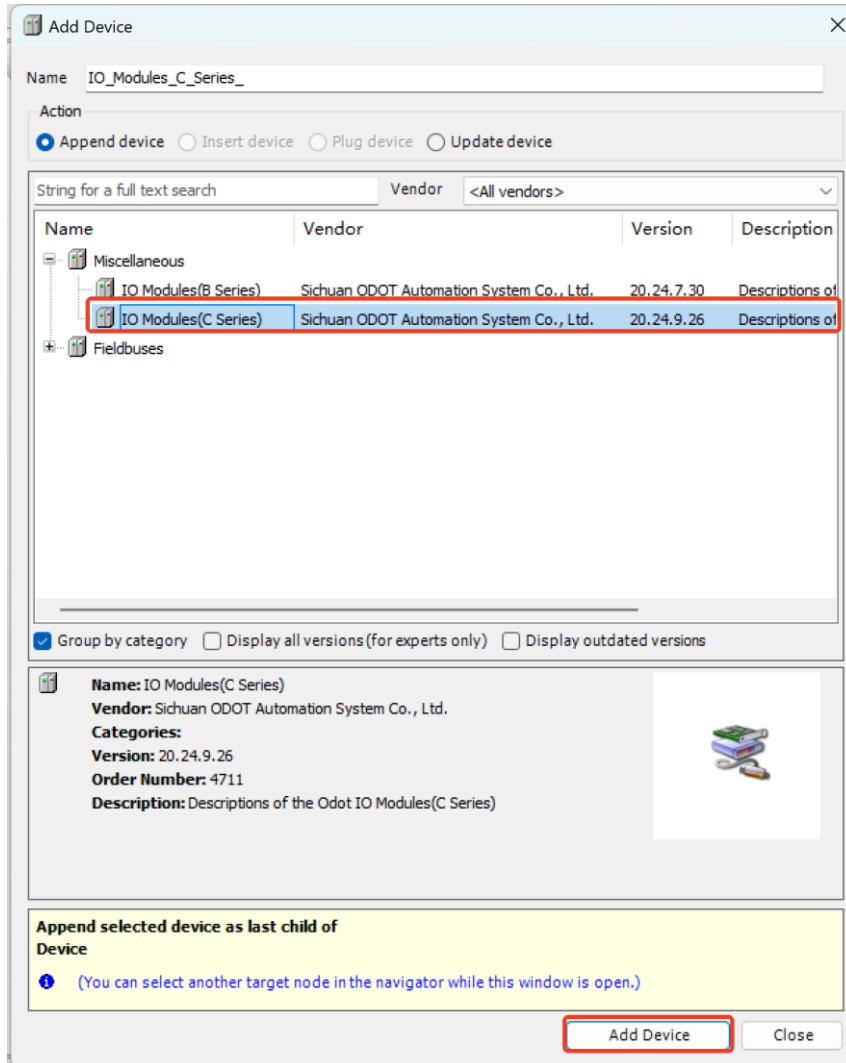

Select the "empty" slot, and insert the corresponding module according to the hardware configuration, and the functions of the module are listed in the selection table.

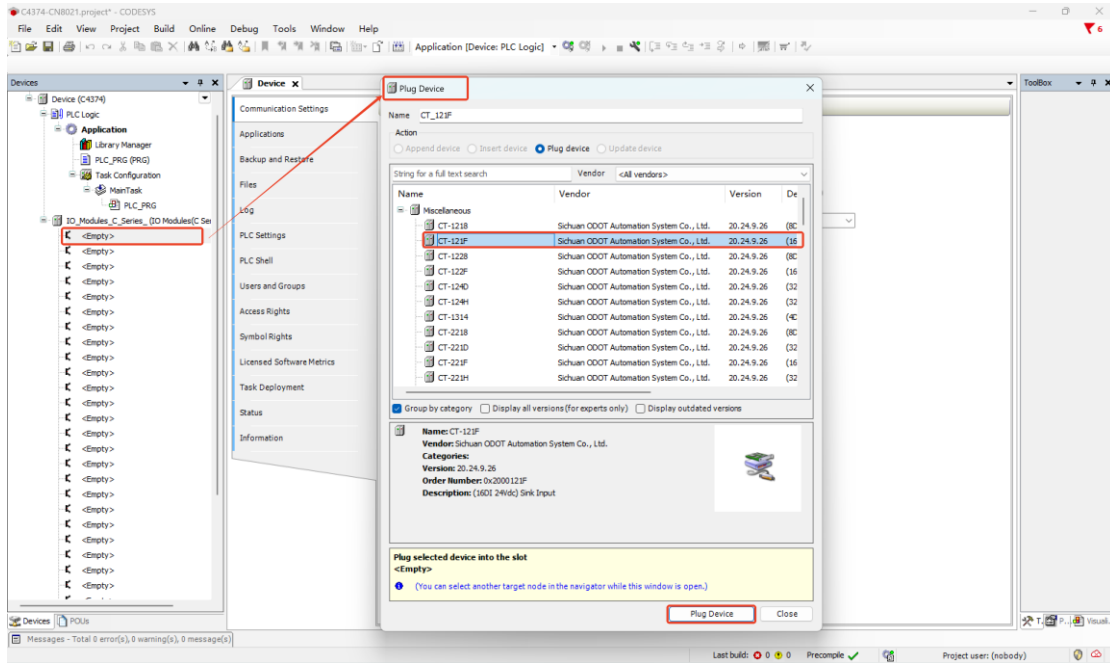

Double-click the module and select I/O Mapping to view the corresponding I/O address and set the mapping relationship.

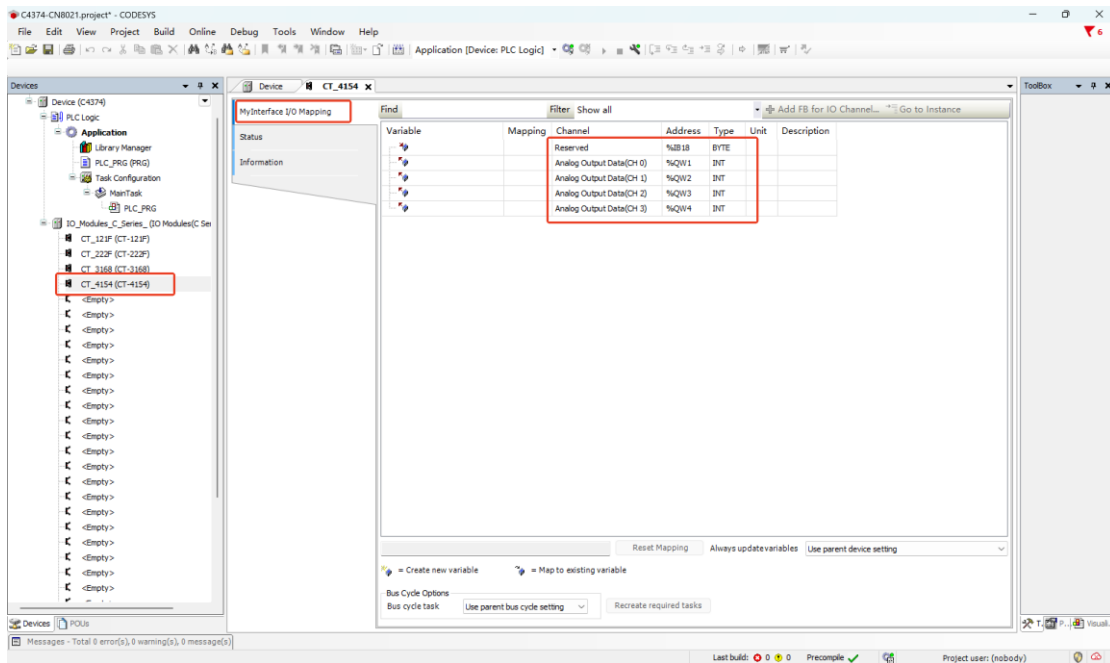

Set the Always Update variable to enable 1 (or use the bus cycle task if not used in any task).

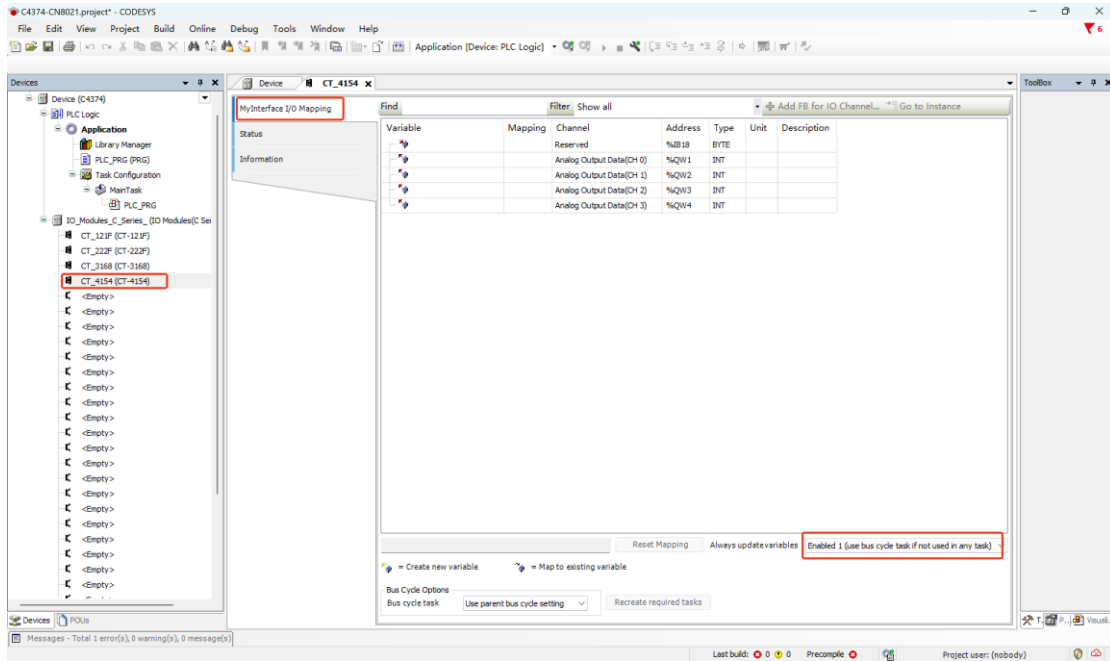

Right-click Device (C4374), select Add Device, select "Fieldbus-CANbus-CANbus", and click Add Device, and don't need to close the "Add Device" window.

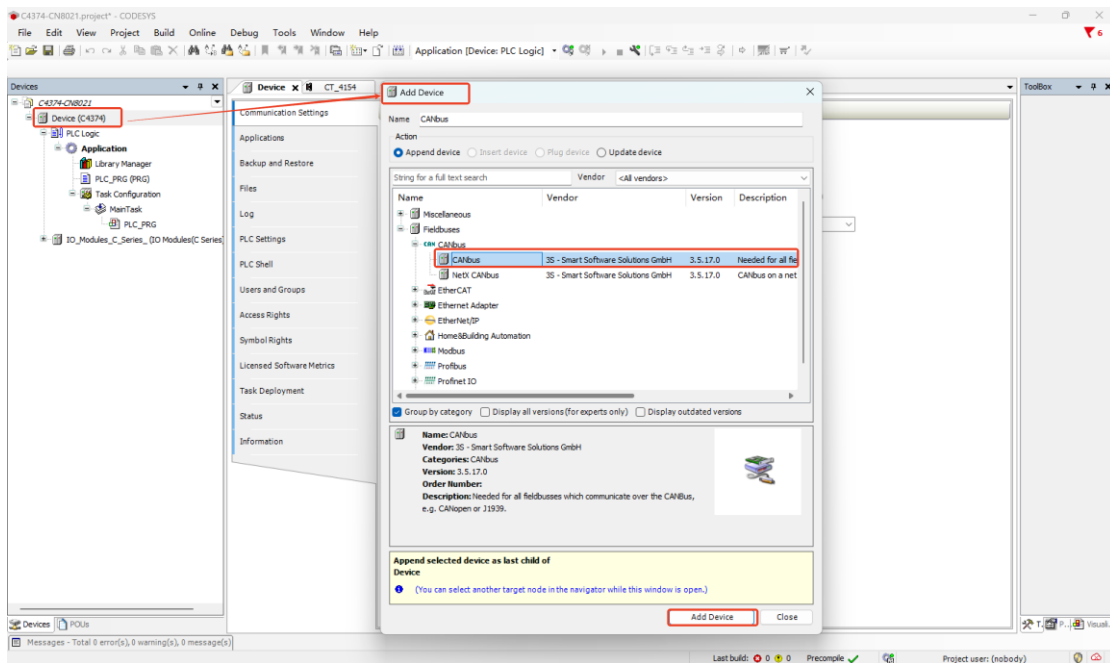

Select the CANbus, in the Add Device window select “CANopen—CANopen Manager—CANopen Manager”, click Add device.

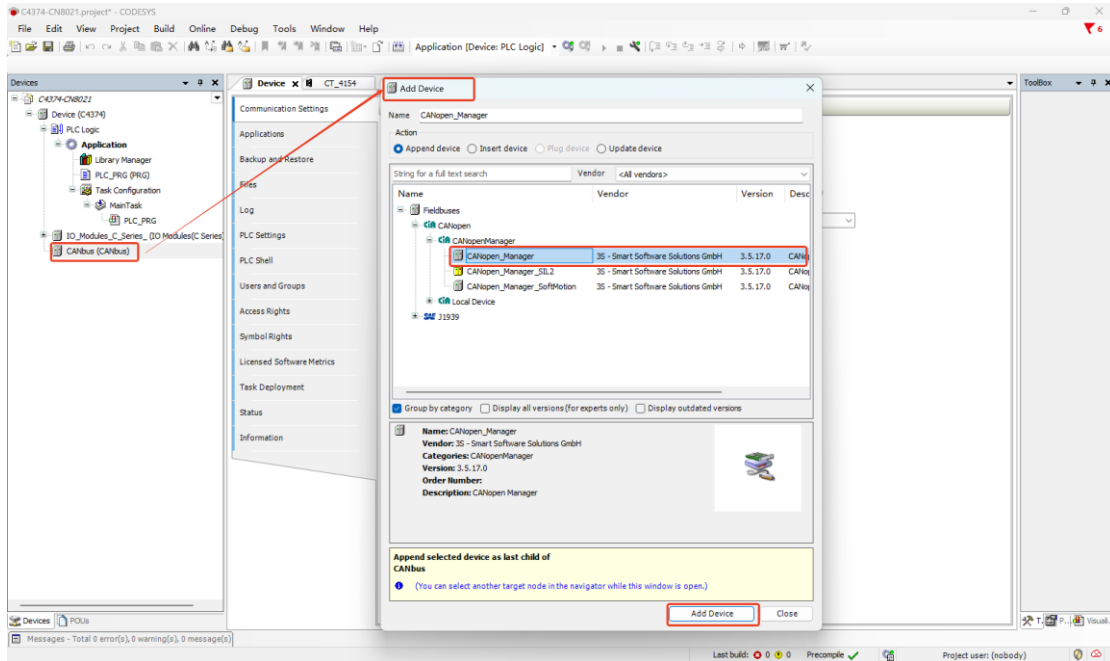

Select CANopen Manager, select Fieldbus - CANopen - Remote Device - CN-8021 CANopen Adapter in the Add Device window, and click Add Device.

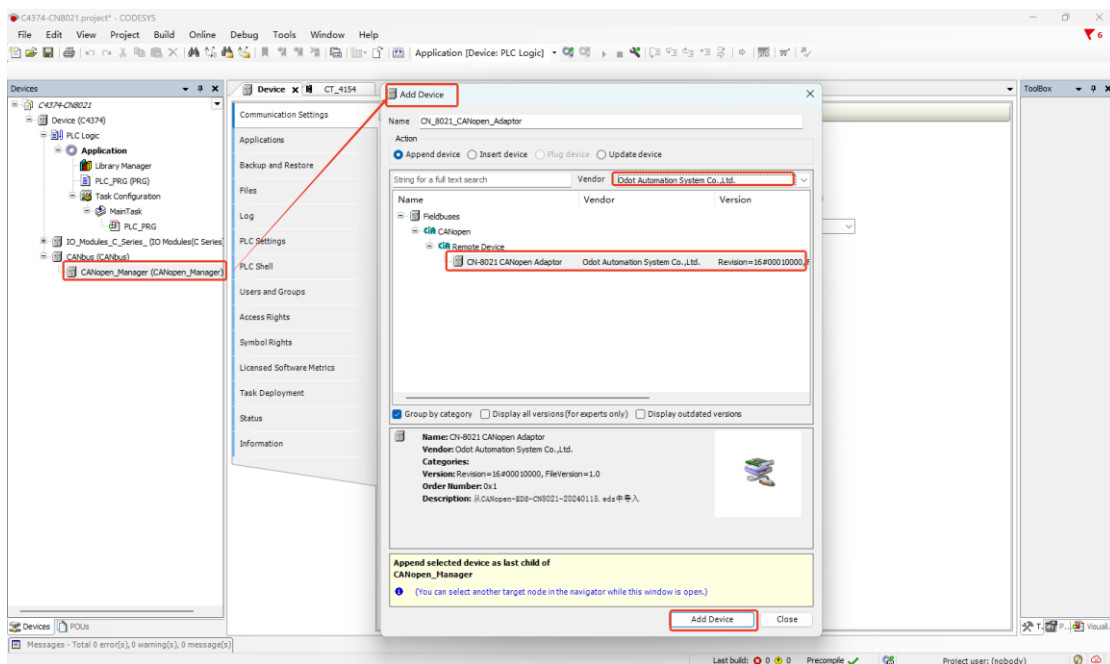

If do not find the CN-8021 module, click Tools - Device Repository - Install, select the configuration file of the CN-8021 module, and click Open to complete the installation of the configuration file.

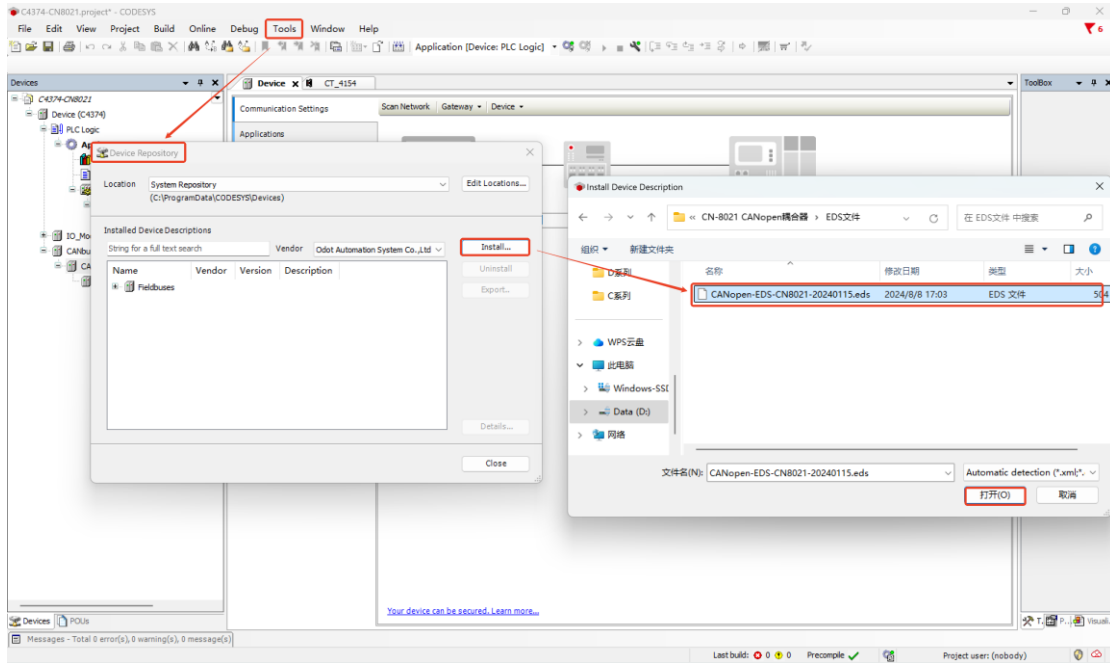

It can use the IO Config software to view the communication configuration parameters of the CN-8021 module.

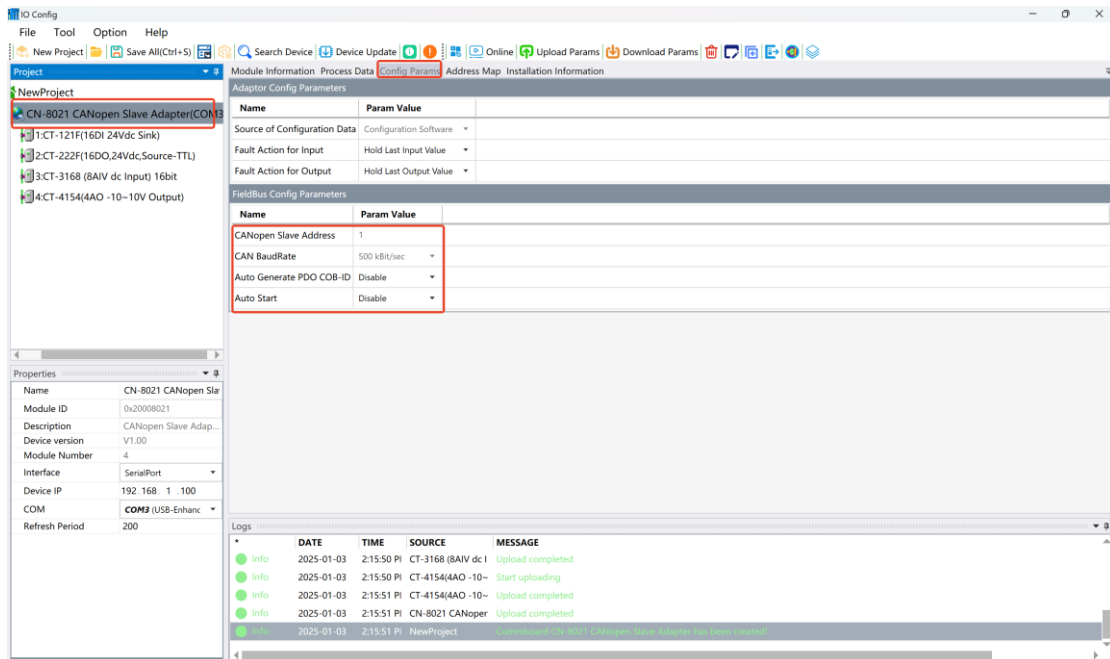

Double-click on CANbus, select "General", and set the baud rate to 500K.

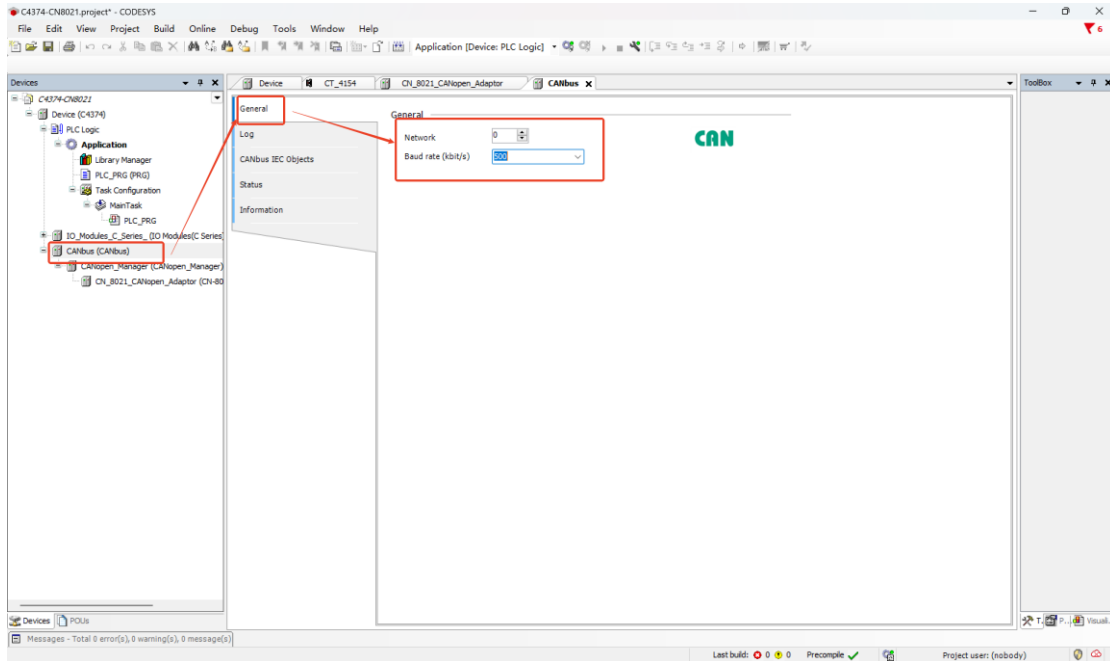

Double-click the CN-8021 CANopen Adapter and select General to configure the node ID number of the module.

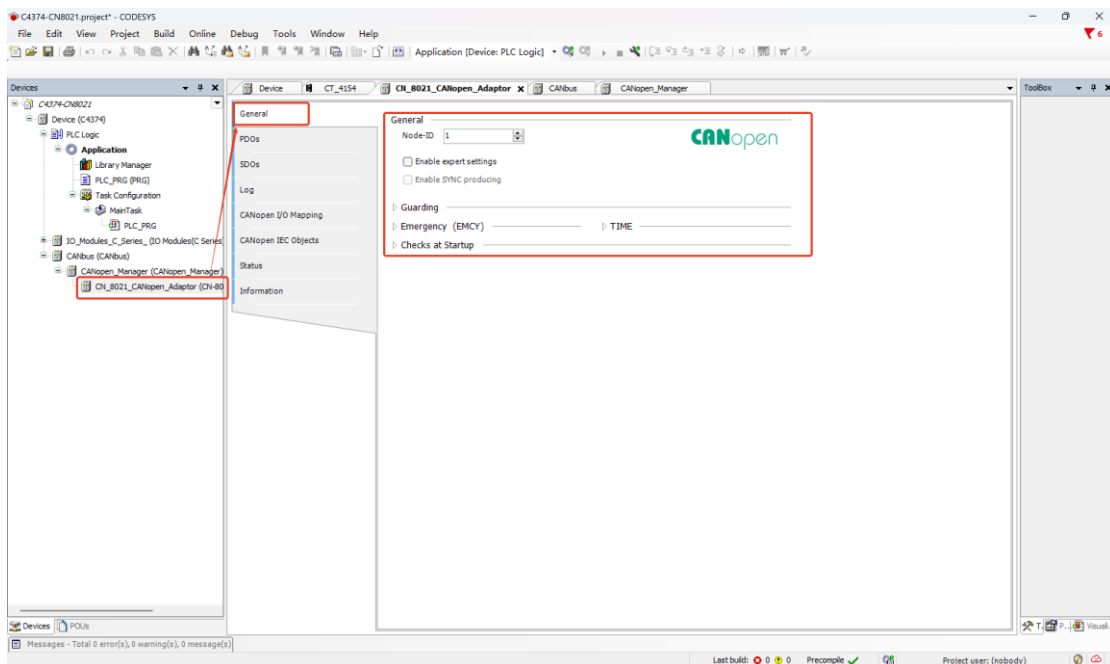

Select PDO to view the PDO mapping of the module, including receiving PDO (master to slave): this part is the process data from PLC to network adapter, generally including "digital output" and "analog output"; Transmission PDO (slave to master): This part is the process data from the network adapter to the PLC, which generally contains "digital inputs" and "analog inputs". By default, 4 RPDOs and 4 TPDOs are

configured, which can be added as needed, and can be configured redundantly, but the configuration cannot be missing (the length of the configured process data can be greater than the actual length of the hardware, and cannot be less than), please refer to the CN-8021 module communication example for the specific configuration method.

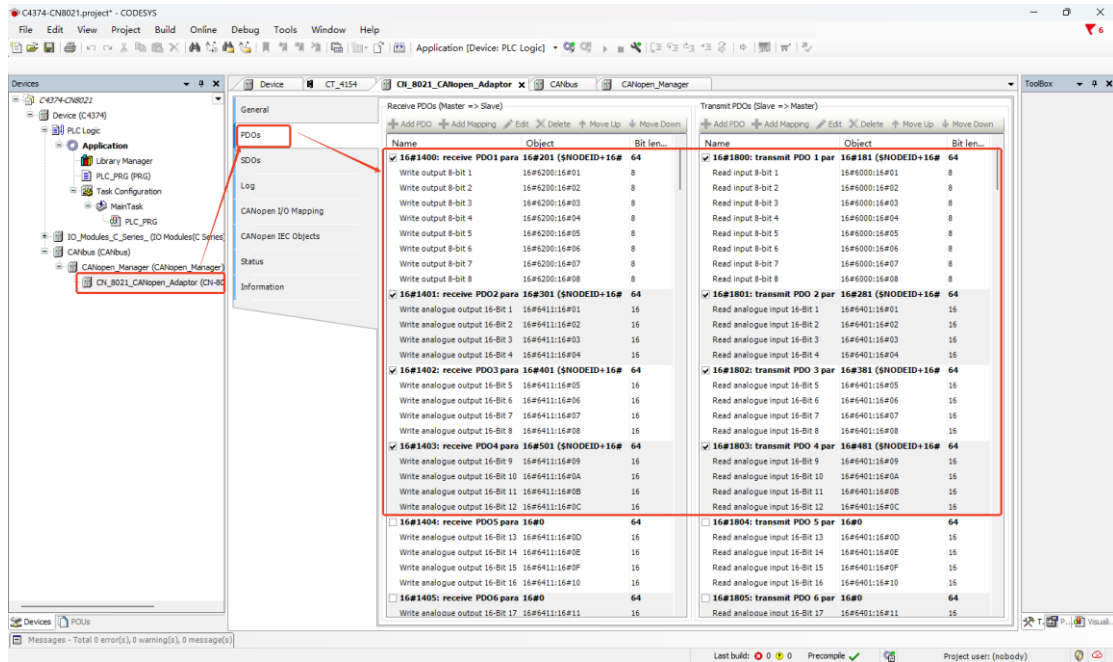

It can use the IO Config software to view the mapping relationship between the IO module in the CN8021, select the CN-8021 module, and click the address table.

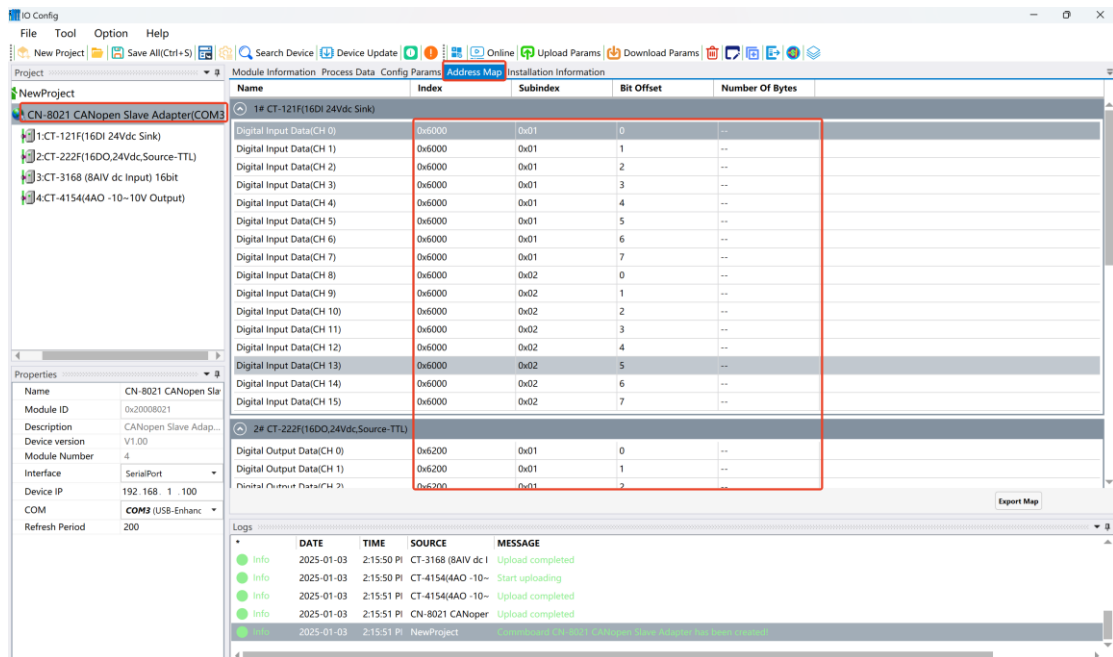

Next, the CT-121F, CT-222F, CT-3168, and CT-4154 modules are used as examples to

illustrate the address correspondence in Codesys software.

The CT-222F module index is 0x6200, and the sub-indexes are 0x01 and 0x02, which correspond to the address in the figure below in Codesys.

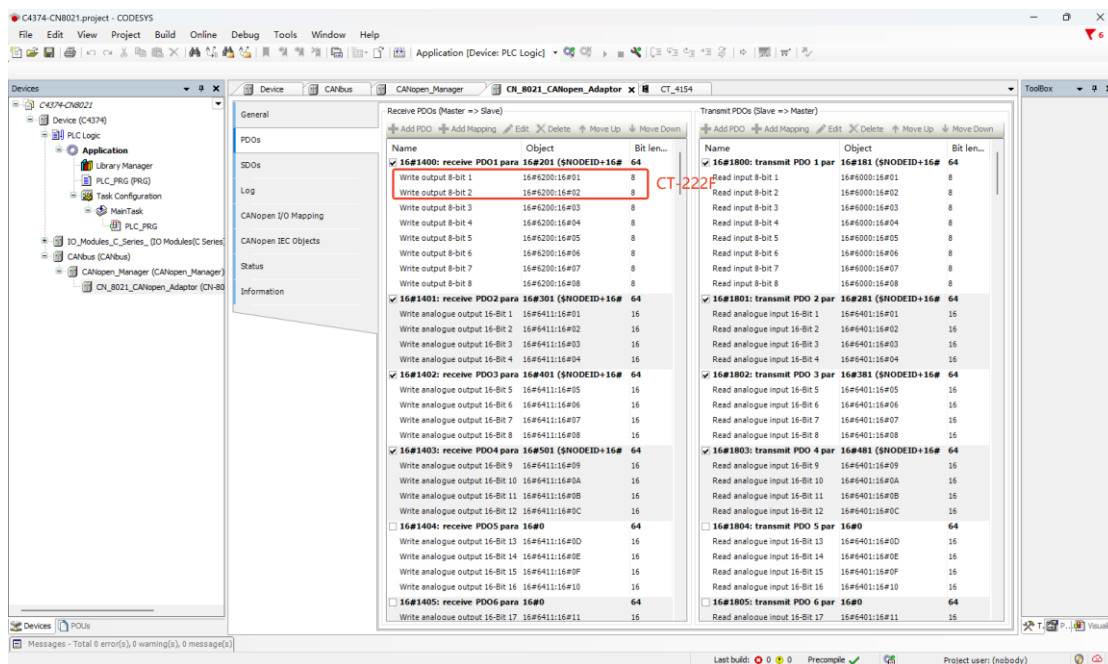
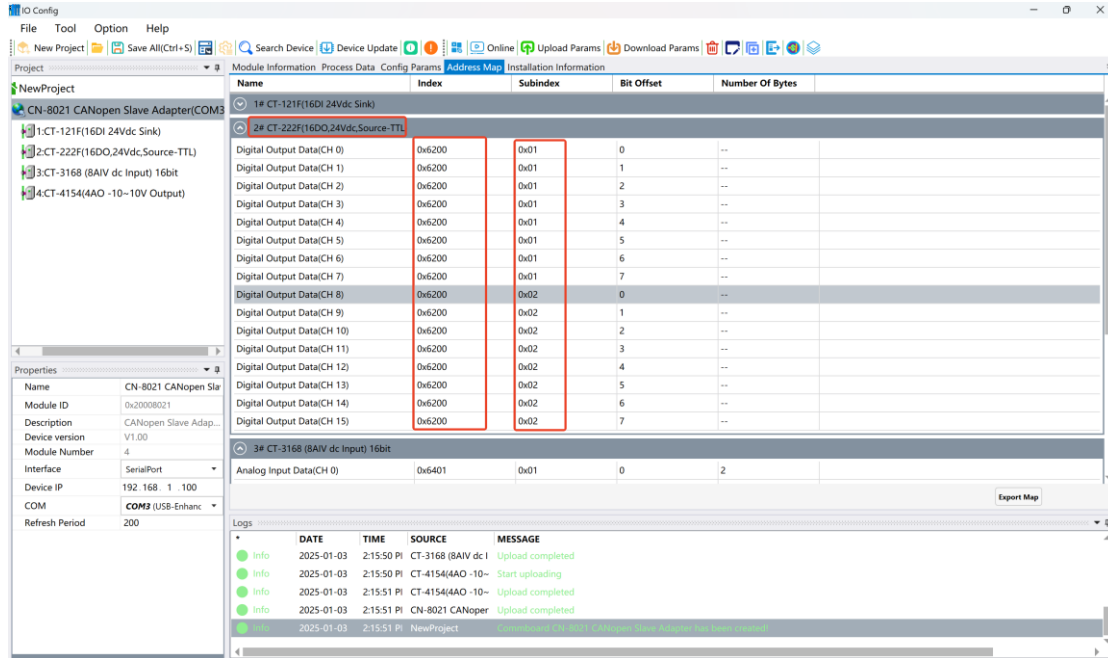

The CT-4154 module index is 0x6411, and the sub-index is 0x01~0x04, which corresponds to the address in the following figure in Codesys.

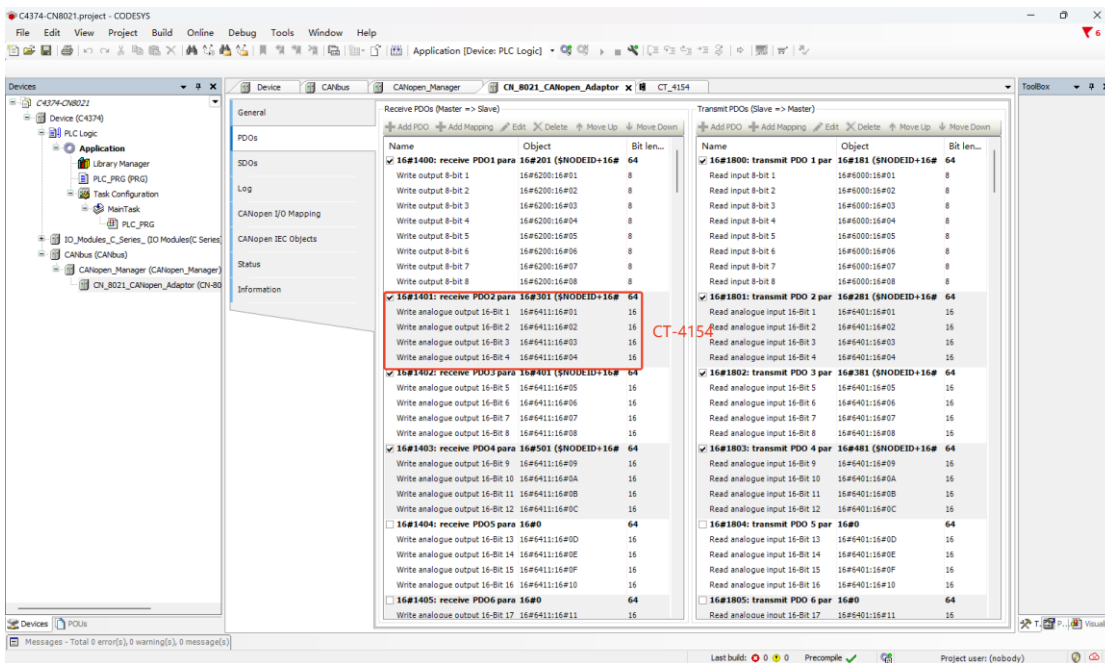
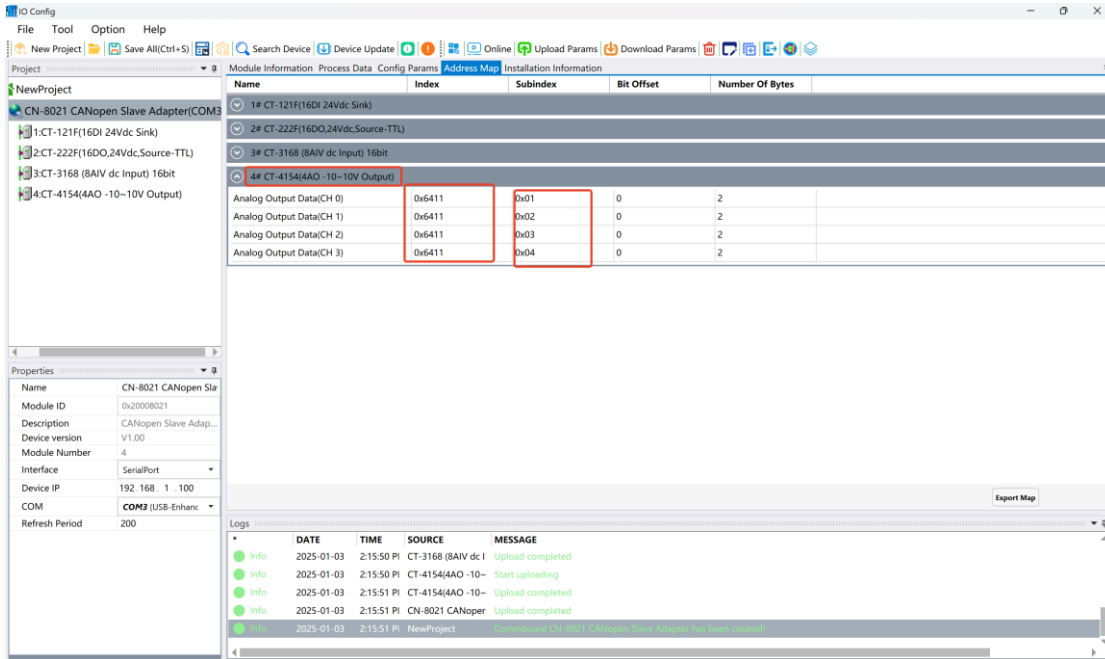

The CT-121F module index is 0x6000, and the sub-indexes are 0x01 and 0x02, which correspond to the address in the following figure in Codesys.

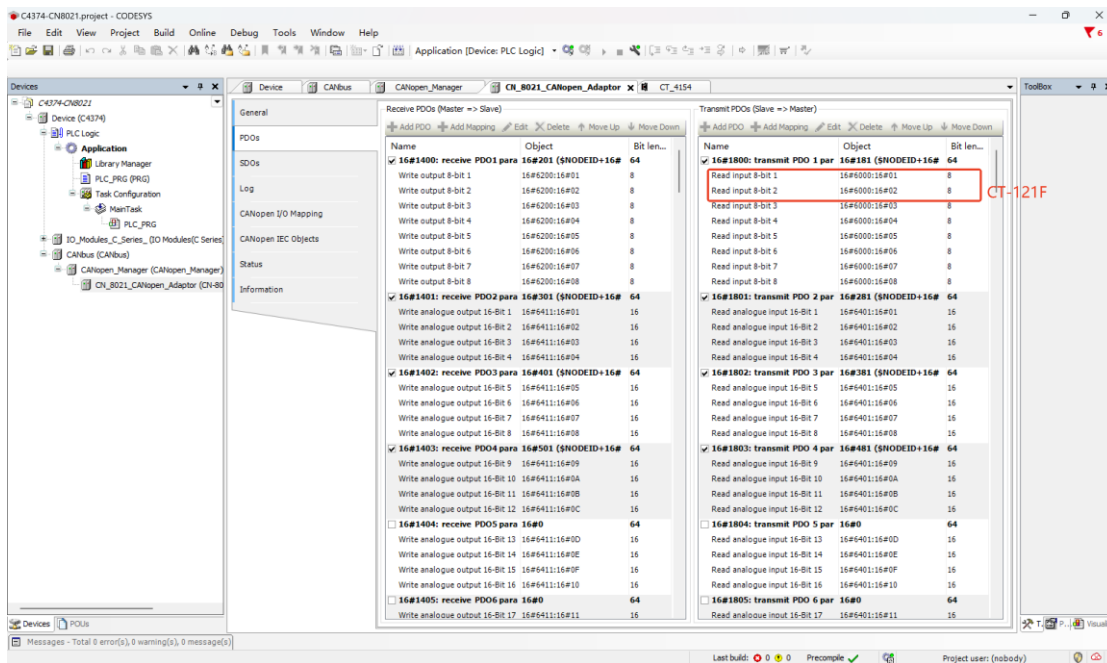
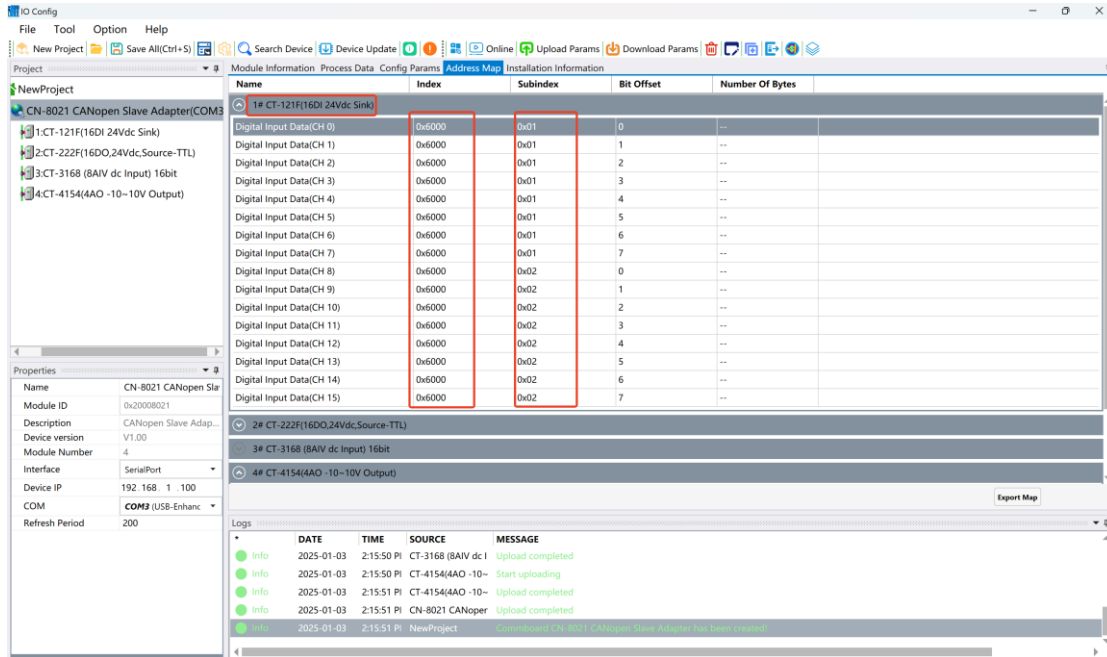

The CT-3168 module index is 0x6401, and the sub-index is 0x01~0x08, which corresponds to the address in the following figure in Codesys.

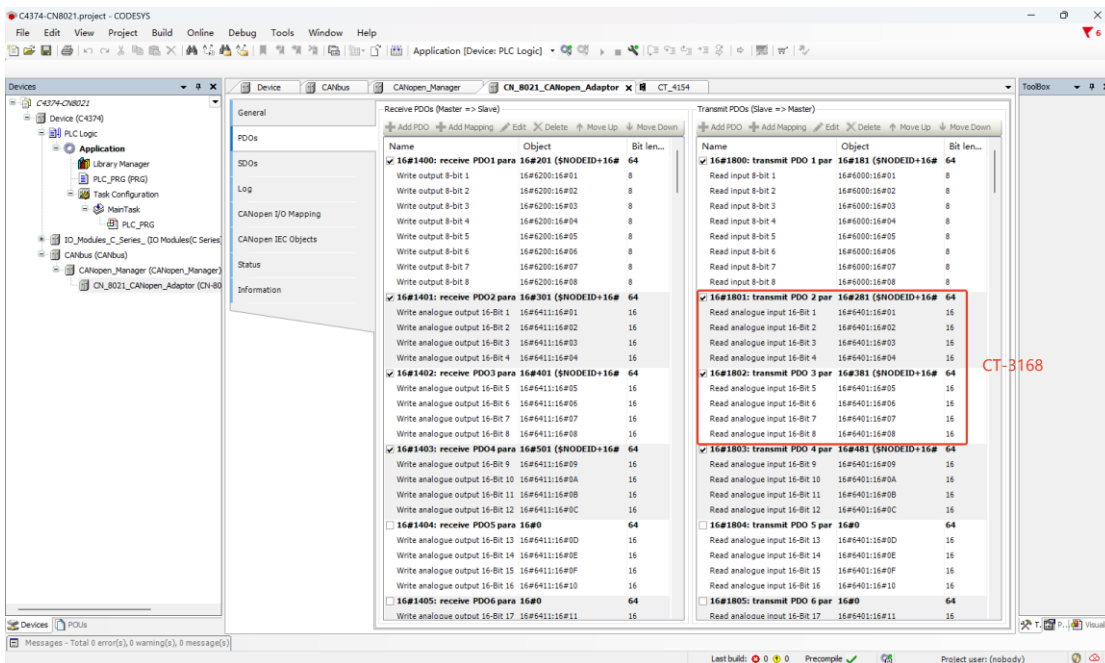
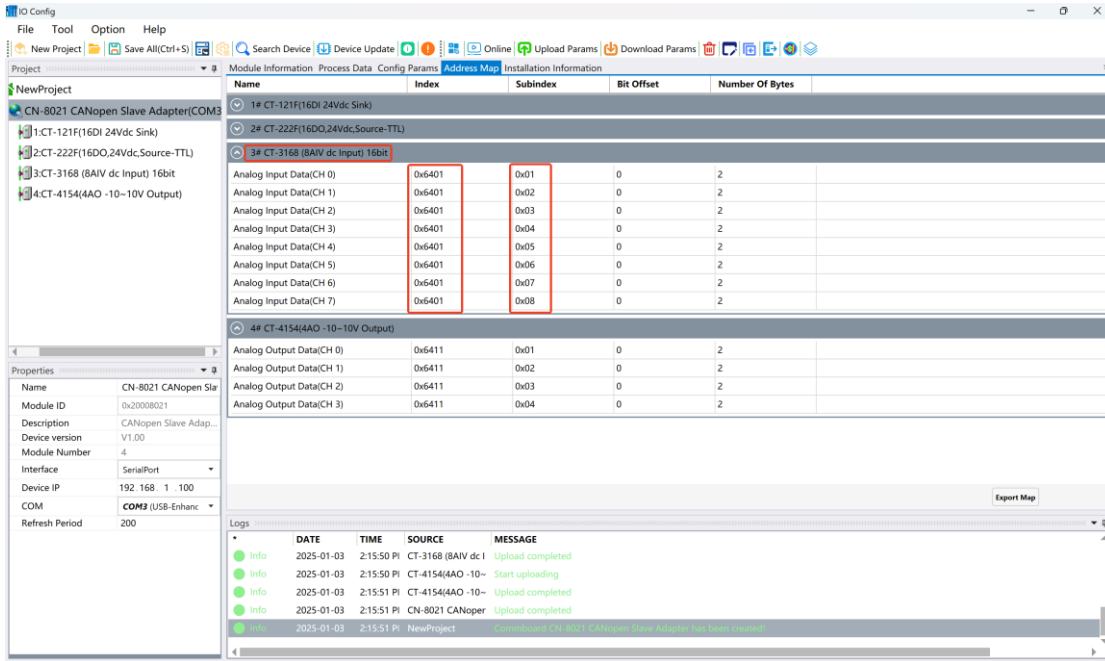

Double-click the CN-8021 CANopen Adapter and select CANopen Address Mapping Table to view the address mapping of the module and set Always Update variable to Enable 1.

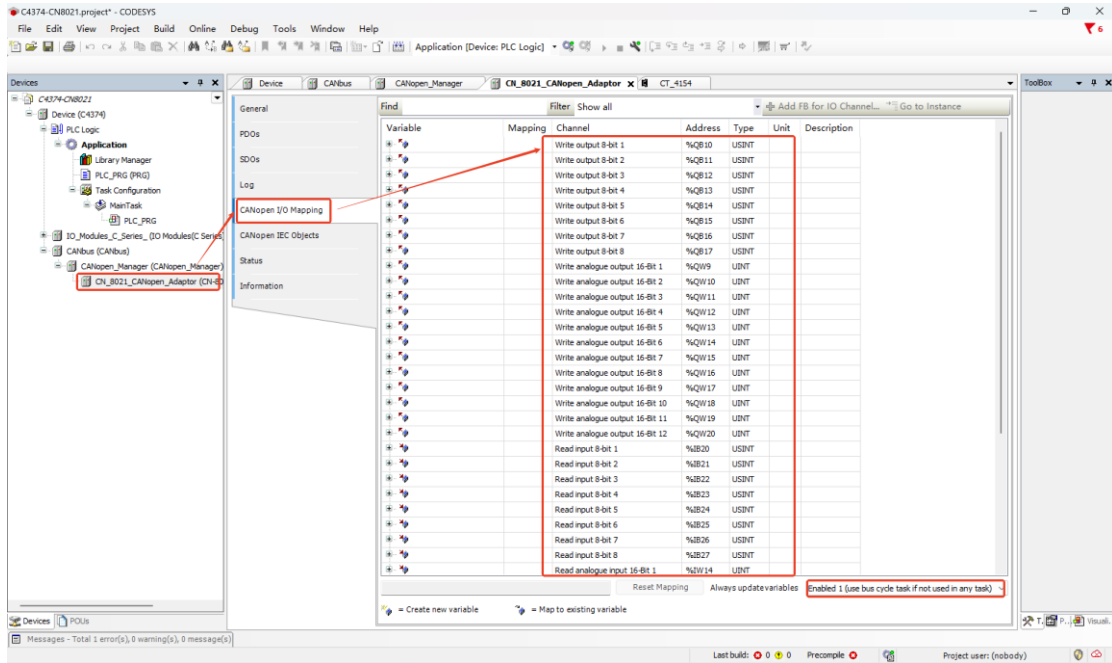

After the parameters are configured, download and log in to the device.

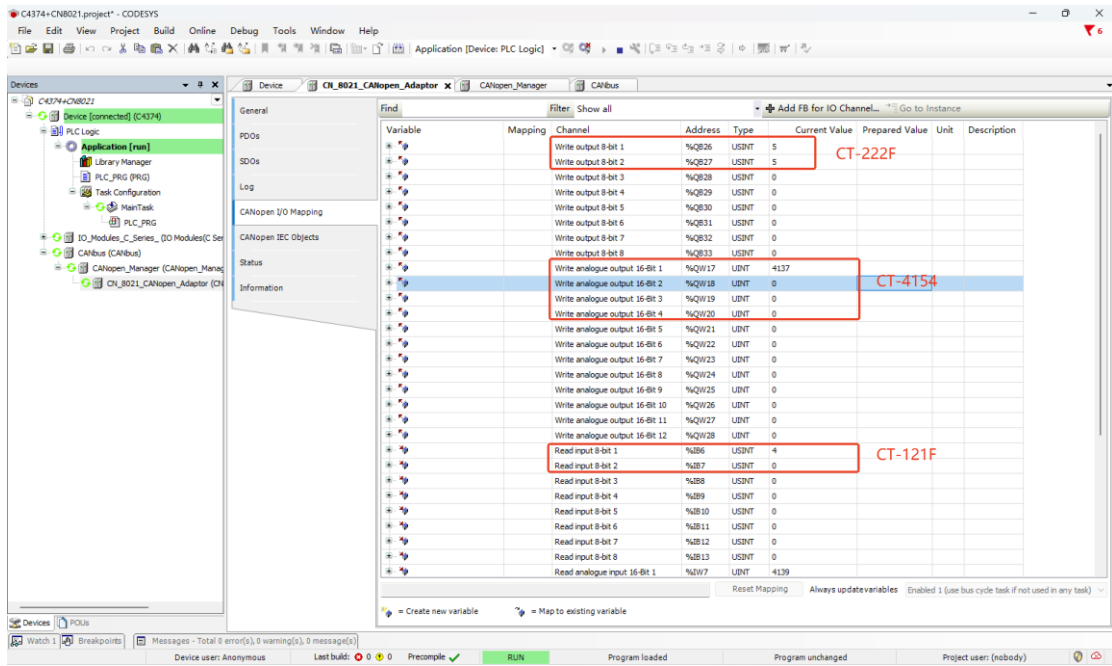

The screenshot shows the CODESYS IDE interface for a PLC project. The main window displays a table of variable declarations for the device 'CN_8021_CANopen_Adaptor'. The table has columns for Variable, Mapping, Channel, Address, Type, Current Value, Prepared Value, Unit, and Description. A red box highlights the row for 'Read analogue input 16-Bit 1', which has a current value of 4139. A red label 'CT-3168' is positioned to the right of this row. The status bar at the bottom indicates the program is in the 'RUN' state.

Variable	Mapping	Channel	Address	Type	Current Value	Prepared Value	Unit	Description
Write analogue output 16-Bit 5			%QW21	USINT	0			
Write analogue output 16-Bit 6			%QW22	USINT	0			
Write analogue output 16-Bit 7			%QW23	USINT	0			
Write analogue output 16-Bit 8			%QW24	USINT	0			
Write analogue output 16-Bit 9			%QW25	USINT	0			
Write analogue output 16-Bit 10			%QW26	USINT	0			
Write analogue output 16-Bit 11			%QW27	USINT	0			
Write analogue output 16-Bit 12			%QW28	USINT	0			
Read input 8-bit 1			%IB6	USINT	4			
Read input 8-bit 2			%IB7	USINT	0			
Read input 8-bit 3			%IB8	USINT	0			
Read input 8-bit 4			%IB9	USINT	0			
Read input 8-bit 5			%IB10	USINT	0			
Read input 8-bit 6			%IB11	USINT	0			
Read input 8-bit 7			%IB12	USINT	0			
Read input 8-bit 8			%IB13	USINT	0			
Read analogue input 16-Bit 1			%IWI7	USINT	4139			
Read analogue input 16-Bit 2			%IWI8	USINT	0			
Read analogue input 16-Bit 3			%IWI9	USINT	0			
Read analogue input 16-Bit 4			%IWI10	USINT	0			
Read analogue input 16-Bit 5			%IWI11	USINT	0			
Read analogue input 16-Bit 6			%IWI12	USINT	0			
Read analogue input 16-Bit 7			%IWI13	USINT	0			
Read analogue input 16-Bit 8			%IWI14	USINT	0			
Read analogue input 16-Bit 9			%IWI15	USINT	0			
Read analogue input 16-Bit 10			%IWI16	USINT	0			
Read analogue input 16-Bit 11			%IWI17	USINT	0			
Read analogue input 16-Bit 12			%IWI18	USINT	0			

7 Appendix

7.1 Modbus-RTU protocol introduction

Only need to understand that Modbus has 8 important function codes corresponding to 4 areas: 4 for reading, 2 for writing a single bit or register, and 2 for writing multiple bits or multiple registers. (Address description uses PLC address)

Modbus storage area

The storage area of the controller (or Modbus device) involved in Modbus is identified by 0XXXX, 1XXXX, 3XXXX, 4XXXX.

Store ID	Name	type of data	Read/write	Storage unit address
0XXXX	Output coil	Bit	Read/write	00001~0XXXX, XXXX: Related to equipment
1XXXX	Discrete input	Bit	Read only	10001~1XXXX, XXXX: Related to equipment
3XXXX	Input register	word	Read only	30001~3XXXX, XXXX: Related to equipment
4XXXX	Output/holding register	word	Read/write	40001~4XXXX, XXXX: Related to equipment

Modbus function code

The Modbus message is relatively fixed, so you only need to understand it a little bit. After reading a few messages, you will know its structure, and you can inquire about it when you need it.

(1) Read output coil status

Function code: 01H

Master query message format:

Address	Function Code	Start Address High	Start Address Low	High Number of Coils	Low Number of Coils	CRC
0x11	0x01	0x00	0x13	0x00	0x25	xxxx

Function: Read the 0XXXX status of the slave output coil.

Note: The start address of the coil of some equipment is 00000, which corresponds to the address 00001 in the equipment, which is sequentially extended.

This example: read the output coil of slave station 0x11, the register start address is 0x13=19, the number of coils is 0x0025H=37; therefore, the function of this query message is: read 0x11(17) slave station output coil 00019—00055, A total of 37 coil states.

Slave response format:

Address	Function Code	Byte count	Coil state 19-26	Coil state 27-34	Coil state 35-42	Coil state 43-50	Coil state 51-55	CRC
0x11	0x01	0x05	0xCD	0x6B	0xB2	0x0E	0x1B	xxxx

Function: Slave machine returns to output coil 0XXXX state

(2) Read discrete input state

Function code: 02H

Master inquiry message format:

address	function code	Start address	Start address low	High number of	Low number of coils	CRC
0x11	0x02	0x00	0xC4	0x00	0x16	xxxx

Function: Read the status of the slave input coil 1XXXX.

Note: The start address of some equipment coils is 10000, which corresponds to the address 10001 in the equipment, which will be extended sequentially.

This example: read the input coil of slave station 0x11, the starting address is 0x00C4=196, and the number of coils is 0x0016=22.

Therefore, the function of this inquiry message is: read 0x11 (17) slave station input coil 10196-10217, a total of 22 discrete input states.

Slave response format:

address	function code	Byte count	DI 10196-10203	DI 10204-10211	DI 10212-10217	CRC
0x11	0x02	0x03	0xAC	0xDB	0x35	xxxx

Function: Slave machine returns to input coil 1 XXXX state

(3) Read output/holding register

Function code: 03H

Master inquiry message format:

address	function code	Register start address high	Register start address low	High register number	Low register number	CRC
0x11	0x03	0x00	0x6B	0x00	0x03	xxxx

Function: Read the value of the slave holding register 4XXXX.

Note: Some device registers start address 40000 corresponds to 40001 address in the device, and it is postponed sequentially.

This example: read the value of the holding register of the slave station 0x11, the starting address is 0x006BH=107, and the number of registers is 0x0003; therefore, the function of this query message is: reading the 3 holding registers 40107-40109 of the slave No. 0x11 (17H) value.

address	function code	byte count	register 40107 high	register 40107 low	register 40108 high	register 40108 low	register 40109 high	register 40109 low	CRC
0x11	0x03	0x06	0x02	0x2B	0x01	0x06	0x2A	0x64	xxxx

Function: The slave returns the value of the holding register: (40107) =0x022B,

(40108) =0x0106, (40109) =0x2A64

(4) Read the input register

Function code: 04H

Master inquiry message format:

address	function code	Register start address high	Register start address low	High register number	Low register number	CRC
0x11	0x04	0x00	0x08	0x00	0x01	xxxx

Function: Read the value of slave station input register 3XXXX.

Note: In some devices, the register start address 30000 corresponds to the address 30001 in the device, and it is extended sequentially.

This example: Reading the value of the input register of slave station 0x11, starting at 0x0008H Note: In some devices, the starting address of the register 30000 corresponds to the address 30001 in the device, and it is extended sequentially.

This example: read the input register value of slave station 0x11, the starting place is 0x0008H, and the register number is 0x0001;

Therefore, the function of this query message: read the value of 1 input register 30008 of slave station 0x11 (17); the number of registers is 0x0001;

Therefore, the function of this query message: read the value of 1 input register 30008 of slave station 0x11 (17);

Slave response format:

address	function code	Byte count	Input register 30008 high	Input register 30008 low	CRC
0x11	0x04	0x02	0x01	0x01	xxxx

Function: Slave station returns the value of input register 30008; (30008) = 0x0101

(5) Force a single coil

Function code: 05H

Master inquiry message format:

address	function code	coil address high	coil address low	Disconnect mark	Disconnect mark	CRC
0x11	0x05	0x00	0xAC	0xFF	0x00	xxxx

Function: Force the value of 0x01(17) slave coil 0XXXX. In some devices, the coil start address 00000 corresponds to the address 00001 in the device, which is

sequentially extended.

Disconnect mark=FF00, Set coil ON。

Disconnect mark=0000, Set coil OFF。

Example: The starting address is 0x00AC=172. Force the No. 17 slave coil 0172 to ON.

Response format: original text return

Function: Force No. 17 slave coil 0172 ON to return the original text

address	function code	Coil address high	Coil address low	Disconnect mark	Disconnect mark	CRC
0x11	0x05	0x00	0xAC	0xFF	0x00	xxxx

(6) Preset single holding register

Function code: 06H

Master inquiry message format:

address	function code	coil address high	Register start address low	register number high	register number low	CRC
0x11	0x06	0x00	0x87	0x03	0x9E	xxxx

Function: Preset order to hold the value of register 4XXXX. In some devices, the coil start address of 40000 corresponds to the address of 40001 in the device, which is sequentially extended.

Example: preset the single holding register 40135 of No. 17 slave to 0x039E;

Response format: original text return

address	function code	coil address high	register start address low	register number high	register number low	CRC
0x11	0x06	0x00	0x87	0x03	0x9E	xxxx

Function: Preset No. 17 slave single holding register 40135 as 0x039E and return to the original text.

(7) Forced multiple coils

Function code: 0FH

Master inquiry message format:

address	function code	coil start address high	coil start address low	number of coils high	number of coils low	Byte count	Coil state 20-27	Coil state 28-29	CRC
0x11	0x0F	0x00	0x13	0x00	0x0A	0x02	0xCD	0x00	xxxx

Function: Force multiple continuous coils 0XXXX to ON/OFF state.

Note: In some devices, the coil start address 00000 corresponds to the address 00001 in the device, which is sequentially extended.

In this example: force multiple continuous coils from the slave station of No. 0x11, the start address of the coil is 0x0013=19, and the number of coils is 0x000A=10

Therefore, the function of this query message is: force the value of 0x11(17) slave station 10 coils 00019-00028; CDH→00019-00026; 00H→00027-00028;

Slave response format:

address	function code	High bit of coil start address	Low bit of coil start address	High number of coils	Low number of coils	CRC
0x11	0x0F	0x00	0x13	0x00	0x0A	xxxx

(8) Preset multiple registers

Function code: 10H

Master inquiry message format:

address	function code	Start register address high	Start register address low	register number high	register number low	Byte count	Data high	Low-level data	Data high	Data low	CRC
0x11	0x10	0x00	0x87	0x00	0x02	0x04	0x01	0x05	0x0A	0x10	xxxx

Function: preset multiple holding register values 4XXXX of the slave.

Note: In some devices, the starting address of the holding register 40000 corresponds to the address 40001 in the device, which is extended in turn.

This example: preset multiple holding register values of slave station 0x11, the starting address of the register is 0x0087=135, and the number of coils is 0x0002=2. Therefore, the function of this query message is: preset the values of 2 holding registers of the slave station of No. 0x11 (17); 0105H→40135; 0A10H→40136.

Response format:

address	function code	Start register address high	Start register address Low	register number high	register number Low	CRC
0x11	0x10	0x00	0x87	0x00	0x02	xxxx

7.2 Brief introduction of serial network topology

RS232

RS232 is one of the serial communication interfaces of industrial control, and it is widely used to connect computer serial interfaces and peripherals. RS232 uses a signal line and a signal return line to form a common ground transmission form. The three-wire connection method can realize full-duplex communication. The transmission signal is a single-ended signal. This common ground transmission is prone to common mode interference. Therefore, the anti-noise interference is weak and the transmission distance is limited. The RS232 interface standard stipulates that the maximum transmission distance standard value is 50 feet (approximately 15 meters) when the symbol distortion is less than 4%. (Long-distance communication above 15m needs to be adopted Modem), the maximum transmission distance is also related to the communication baud rate. In actual use, if the transmission distance is far, please lower the baud rate. In order to reduce the external electromagnetic interference during signal transmission, please use shielded cables as communication cables.

The RS232 interface standard stipulates on TXD and RXD:

RS232 uses negative logic to transmit signals, and takes $-(3\sim 15)$ V signal as logic "1"; takes $+(3\sim 15)$ V signal as logic "0"; voltage between $-3\sim +3$ V It is meaningless, and a voltage lower than -15 V or higher than $+15$ V is also meaningless.

RS232 interface classification:

DB9 male connector



The upper left corner is 1, the lower right corner is 9

9-pin RS232 serial port (DB9)		
PIN	Name	Effect
1	CD	Carrier detect
2	RXD	Receive data

3	TXD	Receive data
4	DTR	Data terminal is ready
5	GND	Signal ground
6	DSR	Data ready
7	RTS	Request to send
8	CTS	Clear to send
9	RI	Ring alert

Because the RS232 interface has the above-mentioned electrical characteristics, it could only realize point-to-point communication.

The RS232 communication wiring diagram is shown in the figure:

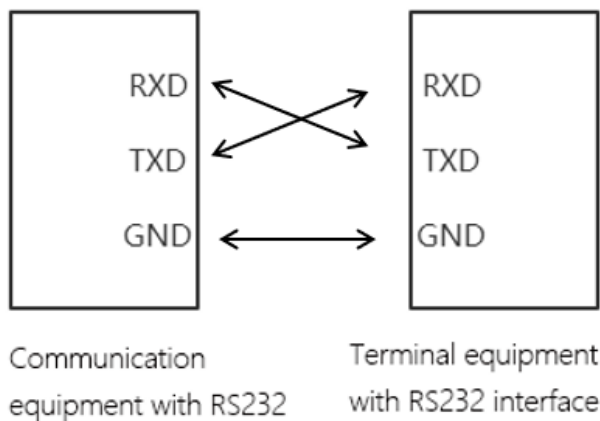

RS422

The full name of RS422 interface standard is "Electrical Characteristics of Balanced Voltage Digital Interface Circuit", which defines the characteristics of the interface circuit. RS422 adopts four-wire plus ground wire (T+, T-, R+, R-, GND), full-duplex, differential transmission, multi-point communication data transmission protocol. It adopts balanced transmission and adopts unidirectional/non-reversible transmission line with or without enabling end. Because the receiver adopts high input impedance and the transmission driver has stronger driving ability than RS232, it is allowed to connect multiple receiving nodes on the same transmission line, up to 10 nodes can be connected. That is, a master device (Master), and the rest are slave devices (Salve). The slave devices cannot communicate, so RS-422 supports point-to-many two-way communication.

The maximum transmission distance of RS-422 is 4000 feet (about 1219 meters), and

the maximum transmission rate is 10Mb/s. The length of the balanced twisted pair is inversely proportional to the transmission rate, and the maximum transmission distance is only possible when the rate is below 100kb/s. Only in a short distance can the highest transmission rate be obtained. Generally, the maximum transmission rate that can be obtained on a 100-meter-long twisted pair cable is only 1Mb/s.

RS-422 needs to be connected to a terminal resistor, and its resistance is required to be approximately equal to the characteristic impedance of the transmission cable. In short-distance transmission, no terminating resistor is needed, that is, no terminating resistor is generally required below 300 meters. The terminating resistor is connected to the far end of the transmission cable.

In the one-master-multi-slave network connection, the sending ends of all slave stations are connected to the receiving end of the last connected to the master station through a daisy chain; the receiving ends of all slaves are connected to the last connected to the master station through a daisy chain. Sender.

RS422 (9Pin)		effect	Remarks
3	R-	Receiving negative	Must connect
2	T-	Send negative	Must connect
7	R+	Receiving positive	Must connect
8	T+	Send positive	Must connect



The upper left corner is 1, the lower right corner is 9

The RS422 communication wiring diagram is shown in the figure:

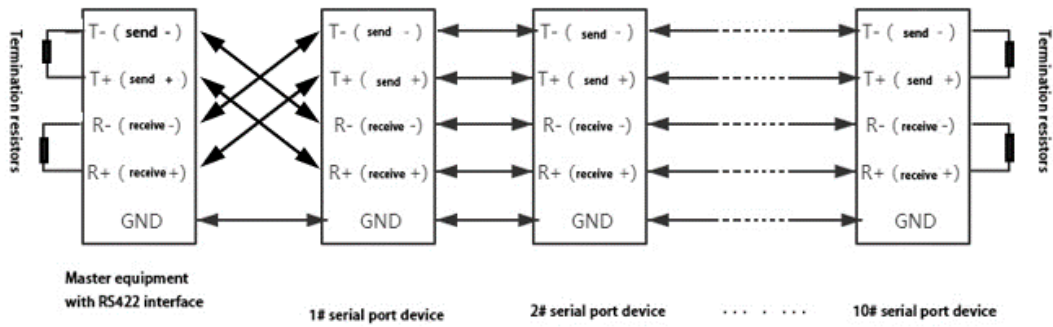

RS485

Since RS-485 is developed on the basis of RS-422, many electrical regulations of RS-485 are similar to RS-422. For example, balanced transmission methods are adopted, and terminating resistors are required to be connected to the transmission line. RS-485 can adopt two-wire and four-wire methods, and the two-wire system can realize true multi-point two-way communication.

RS485 is a standard that defines the electrical characteristics of drivers and receivers in a balanced digital multipoint system. It uses a combination of balanced drivers and differential receivers to enhance the ability to resist common mode interference, that is, to resist noise interference. Since the half-duplex network composed of RS485 interface generally adopts two-wire connection mode, and uses differential signals to transmit data, the voltage difference between the two wires is $-(2\sim6)$ V, which means logic "0", the voltage difference between the two wires $+(2\sim6)$ V means logic "1".

The RS485 signal transmission distance is related to the communication baud rate. The higher the baud rate, the shorter the transmission distance. When the baud rate is not higher than 100KbpS, the theoretical maximum communication distance is about 1200 meters. In actual use, due to Factors such as electromagnetic interference often fail to reach the maximum communication distance. If you are communicating over a longer distance, please lower the baud rate. To reduce the signal's electromagnetic interference during transmission, please use twisted-pair shielded cables as communication cables.

The RS485 bus supports a maximum of 32 nodes without relays. The nodes are

connected by a "daisy chain" connection. Terminal resistors are required at both ends of the communication cable, and the resistance is required to be approximately equal to the characteristics of the transmission cable. impedance. In short-distance transmission, no terminating resistor is needed, that is, no terminating resistor is generally required below 300 meters. The terminating resistor is connected to the two ends of the transmission cable.

RS485 9-pin pin definition:

Pin	Name	Effect	Note
1	Data-/B-/485-	Send positive	Must connect
2	Data+/A+/485+	Receiving positive	Must connect
5	GND	Ground wire	



The RS485 communication wiring diagram is shown in the figure:

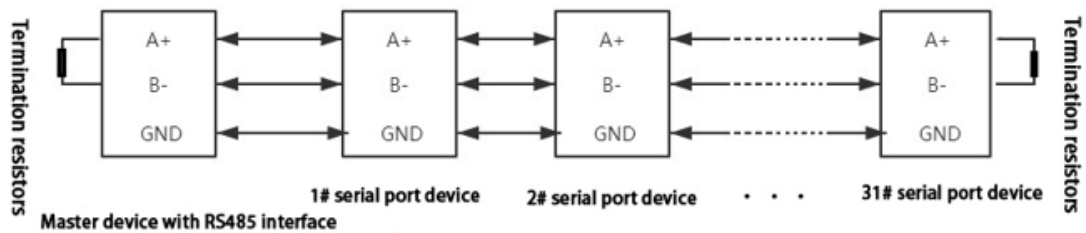

Odot Automation System Co., Ltd.

Add: No. 261 Feiyun Avenue Comprehensive free Trade Zone 204 workshop,
Mianyang, Sichuan, China.

Tel: +86-0816-2538289

Zip Code: 621000

Email: sales@odotautomation.com

Web: www.odotautomation.com

