

## 公司简介



浙江方大合金科技有限公司，作为中国五金行业龙头企业方大控股有限公司的控股子公司，成立于2012年，是一家致力于生产适用于多个行业用硬质合金产品，集设计，开发，生产销售于一体的生产企业。特别是硬质合金电锤钻头，木工刀具，锯齿片，开孔器，矿山用钎片，球齿，棒材，板材，旋转锉，非标等复杂产品，在国内外享有盛誉。产品远销欧美，中东，东南亚，非洲等国家和地区，深受广大客户的欢迎和信赖。

依托母公司积聚的实力，我司装备了整套生产高档硬质合金所必需的生产，研发，检测设备。检测设备齐全，检验方法科学，管理先进。同时本公司技术力量雄厚，拥有一批经验丰富的生产技术骨干，还聘请了行业内经验丰富的粉料，模具，压制，烧结等高级工程师和教授级高工，他们在各自的领域都有着几十年的技术生产管理经验，为我司生产，研发高质量以及稳定质量的硬质合金产品打下了坚实的基础。目前公司已拥有五项专利，具有年产600吨各种类型的硬质合金制品的能力。

公司本着“以客户为中心，为用户提供全方位服务”为原则，提供各种以客户要求为中心设计生产的产品。同时，根据我司所具备的开发经验，为客户打造相关领域的产品。

## **C**ompany Overview



Fangda Cemented Carbide Technology Co., Ltd(FDCC), a wholly owned subsidiary of Fangda Holding Co., Ltd-leading company in the field of hardware in china was set up in 2001.It specializes in manufacturing, designing, R&D, producing and selling tungsten carbide products. Its tungsten carbide tips for wood-cutting tools, saw tips, tips for hollow saw, tips for hammer drill bit , tips for coal mining tools, buttons for DTH button bit, rods, strips, rotary bur heads, irregular & -complicated products, ect enjoy a good reputation in china. The products are sold to countries and areas in Europe and America, Middle East, Eastern-South Asia, Africa, etc and are warmly welcomed and trusted by the customers.

Aiming at customers' needs and provide perfect service for customers as its policy. FDCC offers the service to manufacture different kinds of tungsten carbide products according to the customers' requirements. Also, with its rich experience, the company also serves to design and manufacture specialized products for customers. FDCC warmly welcome customers domestically and abroad.

**硬质合金牌号\性能\应用 Carbide Grade\Property\Application**

国标牌号 GB Grade	ISO牌号 ISO Grade	硬度 HRA≥	密度 (g/cm <sup>3</sup> )≥	抗弯强度 (N/mm <sup>2</sup> )≥	应用Application
FD05E	-	87.8	14.95	2500	特粗晶粒合金，适用于水泥路修复铣刨齿。 Extra coarse grain size, suitable for milling and shaping teeth in cement road repair.
FD10E	-	87.6	14.90	2700	特粗晶粒合金，适用于沥青路修复铣刨齿。 Extra coarse grain size, suitable for milling teeth in asphalt road repair.
FD05A	G05	90.5	14.93	3000	适用于球齿、潜孔钻头球齿。 Suitable for making button bit, DTH button bit.
FD15	G15	88.9	14.71	2870	适用于球齿、潜孔钻头球齿。 Suitable for making button bit, DTH button bit.
FD40E	G40	85.8	14.30	2800	特粗晶粒合金，适用于截煤齿。 Extra coarse grain size, suitable for making coal mining teeth.
YG8	G10	90.3	14.73	2950	适用于地质勘探，煤炭采掘。钻进煤层无矽化面页岩钾盐。岩盐及其它均质岩石。亦适用于中硬砂岩，灰岩及软硬交替的岩石。也适用于建工钻头。 Suitable for geological exploration and coal mining. Drilling into coal seams without silicified shale potassium salts. Rock salt and other homogeneous rocks. It is also suitable for medium hard sandstone, limestone, and rocks with alternating softness and hardness. Also applicable to construction drill bits.

**硬质合金牌号\性能\应用 Carbide Grade\Property\Application**

国标牌号 GB Grade	ISO牌号 ISO Grade	硬度 HRA≥	密度 (g/cm <sup>3</sup> )≥	抗弯强度 (N/mm <sup>2</sup> )≥	应用Application
YG95	-	87.9	14.58	2650	适用于冲击回转钻头的钎片及、球齿、钻凿中硬及坚硬层。也适用于建工钻头。 Suitable for impact rotary drill bits, including - drill bits, buttons, and drilling hard and hard layers. Also applicable to construction drill bit.
YG11C	-	87.2	14.40	2730	适用于冲击回转钻头的钎片及矿用牙轮钻、球齿、钻凿坚硬层。也适用于建工钻头。 Suitable for drill bits with impact and rotation, as well as mining cone drills, ball teeth, and drilling hard and hard layers. Also applicable to construction drill bits.
YG13C	G30	86.7	14.18	2850	适用于制造石油牙轮钻及截煤齿。 Suitable for making tri-cone bits and coal mining teeth.
YG16C	-	85.8	13.85	2950	适用于制造石油牙轮钻及金刚石复合片基托。 Suitable for manufacturing oil-field tri-cone bit and diamond composite disc bases.

牙轮钻头用硬质合金  
Carbide Buttons for Tri-cone Bits

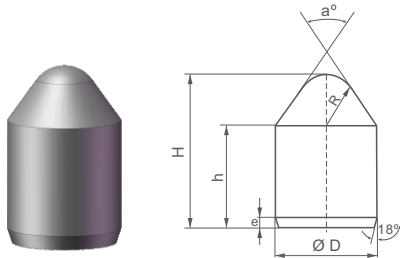

锥型齿  
Conical Button

型号 Type	Dimension(mm)				
	D	H	h	e	a°
FZ0810	8.0	10.0	6.5	1.5	35°
FZ0812	8.0	12.0	8.5	1.5	35°
FZ1011	10.0	11.0	7.1	1.5	35°
FZ1013	10.0	13.0	9.1	1.5	35°
FZ1015	10.0	15.0	9.9	1.5	35°
FZ1215	12.0	15.0	10.2	1.5	35°
FZ1218	12.0	18.0	13.0	1.5	35°
FZ1416	14.0	16.0	9.5	1.5	35°
FZ1418	14.0	18.0	12.5	1.5	35°
FZ1420	14.0	20.0	13.7	1.5	35°
FZ1422	14.0	22.0	15.7	1.5	35°
FZ1625	16.0	25.0	17.3	2.0	35°

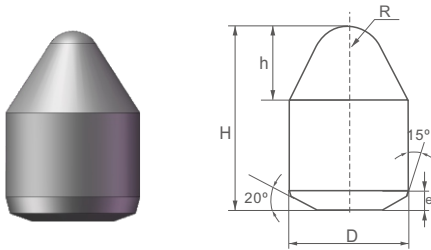

锥型齿  
Conical Button

型号 Type	Dimension(mm)				
	D	H	h	R	e
FZ2071	7.0	10.6	3.5	2.5	1.3
FZ2081	8.0	11.5	4.0	3.0	1.5
FZ2091	9.0	12.6	4.5	3.0	1.6
FZ2010	10.0	14.2	6.1	2.0	1.8
FZ2011	11.0	17.9	6.5	2.5	2.1
FZ2013	13.0	19.9	8.0	4.0	1.9
FZ2015	15.0	22.0	9.0	5.0	2.5
FZ2020	20.7	28.2	10.9	7.9	3.3
FZ2023	23.9	42.7	18.4	7.0	4.0
FZ2028	28.6	44.4	22.2	7.6	4.0

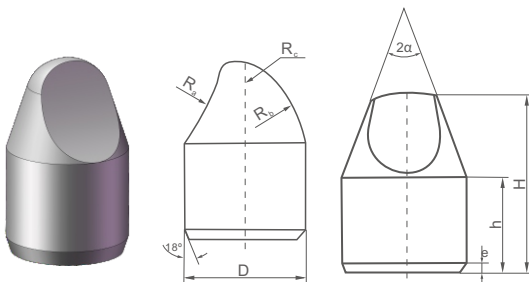

勺型齿  
Scoop Button

型号 Type	Dimension(mm)							
	D	H	h	R <sub>a</sub>	R <sub>b</sub>	R <sub>c</sub>	α	e
FS1421	14.0	21.0	12.0	12.0	20.0	2.5	18	1.5
FS1623	16.0	23.0	12.0	15.0	23.0	2.5	18	1.5
FS1626	16.0	26.0	14.0	20.0	28.0	2.5	18	2.0
FS1724	17.0	24.0	13.0	16.0	25.0	3.0	20	2.0
FS1930	19.0	30.0	17.0	16.0	25.0	3.0	15	2.0
FS2240	22.0	40.0	21.0	20.0	30.0	3.0	13	2.0
FS2545	25.0	45.0	23.0	30.0	35.0	3.5	13	2.0

\* Customization is available to customers' requirement.

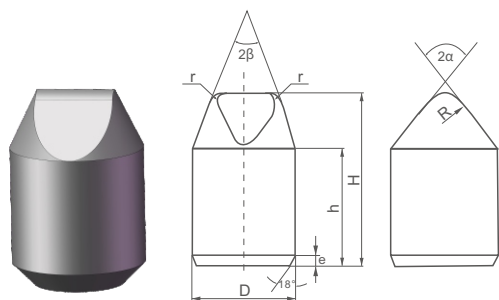

边楔齿  
Wedge-edge Button

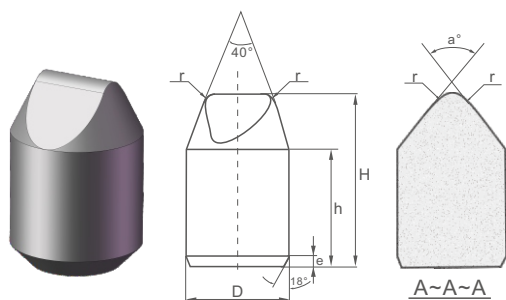

边楔齿  
Wedge-edge Button

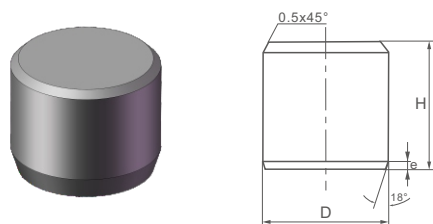

平头齿  
Flat Top Button

型号 Type	Dimension(mm)							
	D	H	h	R	r	e	α	β
FX0810	8.0	10.0	6.5	2.0	1.8	1.5	45	45
FX1011	10.0	11.0	7.0	2.5	2.0	1.5	45	45
FX1013	10.0	13.0	9.0	2.5	2.0	1.5	45	45
FX1115	11.0	15.0	8.0	2.7	2.5	1.5	22.5	22.5
FX1215	12.0	15.0	9.0	3.0	2.5	1.5	45	45
FX1217	12.0	17.0	10.5	3.5	3.0	1.5	35	35
FX1418	14.0	18.0	10.0	3.5	3.0	1.5	45	45
FX1420	14.0	20.0	11.0	2.7	3.0	1.5	35	35
FX1520	15.0	20.0	12.0	3.0	3.0	2.0	40	40
FX1621	16.0	21.0	11.0	2.6	3.0	2.0	35	35
FX1623	16.0	23.0	12.0	3.0	3.5	2.0	30	30
FX1721	17.0	21.0	13.0	4.0	3.5	2.0	40	40
FX1724	17.0	24.0	13.0	3.5	3.5	2.0	30	30
FX1929	19.0	29.0	17.0	4.0	3.0	2.0	30	30

型号 Type	Dimension(mm)						
	D	H	h	R	r	e	α°
FB1417	14.0	17.0	12.0	3.0	2.5	1.5	90
FB1418	14.0	18.0	12.0	3.0	2.5	1.5	80
FB1419	14.0	19.0	12.0	3.0	2.5	1.5	75
FB1621	16.0	21.0	14.0	3.0	2.5	2.0	70
FB1924	19.0	24.0	15.0	3.5	3.0	2.0	70
FB2230	22.0	30.0	17.0	3.5	3.0	2.0	60

型号 Type	Dimension(mm)		
	D	H	e
FP0607	6.0	7.0	1.5
FP0707	7.0	7.0	1.5
FP0807	8.0	7.0	1.5
FP0908	9.0	8.0	1.5
FP1008	10.0	8.0	1.5
FP1109	11.0	9.0	1.5
FP1210	12.0	10.0	1.5
FP1412	14.0	12.0	1.5

\* Customization is available to customers' requirement.