

# HPERV

# DC INVERTER



Purification



Ventilation and Heat Recovery



Cooling/Heating



Dehumidification



# AIRWOODS

## — EVERYTHING YOU NEED TO CREATE A COMFORTABLE, HEALTHY AND ENERGY-EFFICIENT INDOOR CLIMATE



### **PURIFICATION**

Outdoor fresh air passes through the primary filter and F8 filter at OA side, to arrest the dust/ PM2.5/ other pollutants.



### **VENTILATION AND HEAT RECOVERY**

Introduce outdoor fresh air into the room & extract the stale air out; It recovers the heating in winter and recover cooling in summer.



### **PRE-HEATING/ PRE-COOLING**

After the first stage heat recovery, the air passes through the condensor for further heating/cooling.



### **DEHUMIDIFICATION**

The two airstreams run through the heat exchanger and condensor, it can decrease the moisture of fresh air.





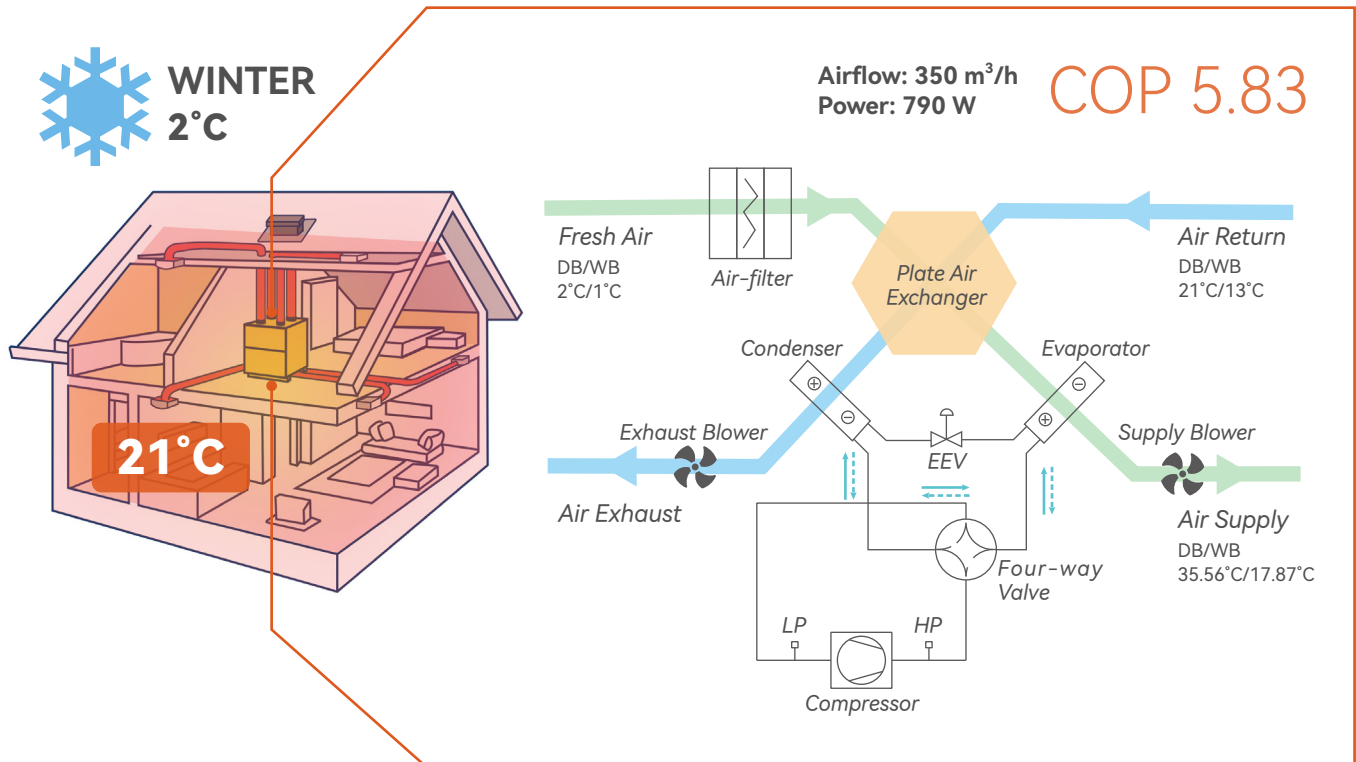
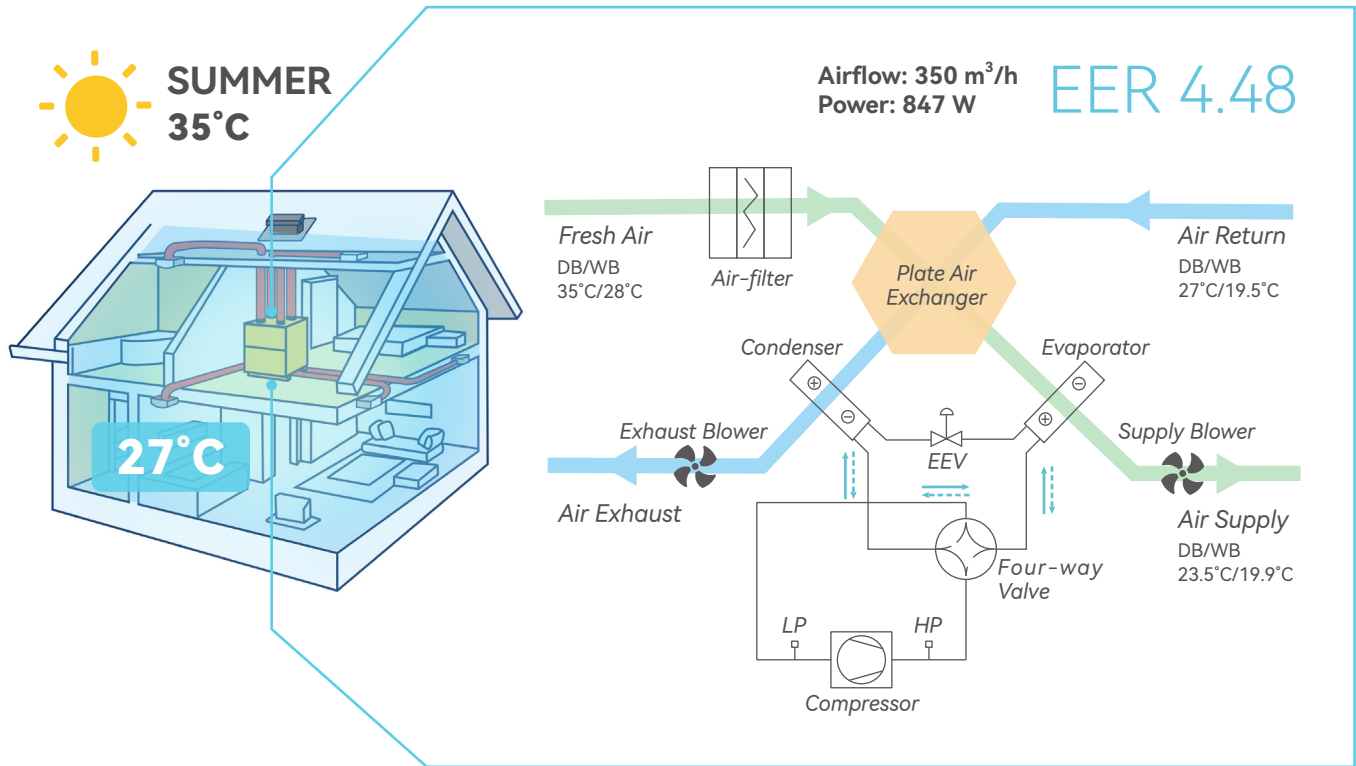

A constant supply of fresh air in the indoor spaces in which we spend more than 70% of our time is vital to our health. Airwoods heat pump energy recovery ventilator (HPERV) is an innovative product that combines fresh air purification, heating/cooling, heat recovery, and dehumidification in one machine. It can provide you with comfortable and healthy indoor air while saving energy and money. It provides the ideal solution for air tight buildings in which the windows often remain closed due to noise, dust particles and energy loss.

With a heat exchanger and heat pump system inside, Airwoods HPERV delivers clean and fresh air in a double energy recovery system. For example, 35°C fresh air in summer time can be cooled to 23.5°C, while 2°C fresh air in the winter time can be heated to 35.5°C. It can work as air conditioner in Autumn/ Spring or at night, when outdoor is 10-28°C. Besides, it can remove the excess humidity, prevent furniture mold build-up and keep the indoor air at comfortable temperature and humidity.

# WORKING PRINCIPLE



# FEATURES

-  Double energy recovery, **COP over 6\***.
-  Fresh air preconditioning, save your electricity bill on heating system and AC system greatly.
-  Work as an independent air conditioner in suitable seasons and places.
-  Low noise level of 37/42 dB(A).
-  Equipped with EC fans & DC inverter compressor to minimize energy consumption.
-  Wide working ambient conditions from -15°C ~ 50°C.
-  Indoor air quality monitoring like CO<sub>2</sub>, humidity, TVOC and PM2.5.

\* The lab condition is: indoor: 21°C/13°C, outdoor: -7°C/-9°C.



## Advantages Compared with Standard ERV

SUMMER CONDITIONS			
No	Description	Temperature	Relative Humidity
1	Outside Temperature OA	35°C	59.10%
2	Inside Temperature RA	27°C	49.80%
3	Fresh Air (Standard Heat Recovery Units) SA	29.24°C	55.48%
4	<b>Fresh Air (Heat Pump Heat Recovery Units) SA</b>	<b>23.5°C</b>	<b>72.11%</b>

WINTER CONDITIONS			
No	Description	Temperature	Relative Humidity
1	Outside Temperature OA	2°C	83.84%
2	Inside Temperature RA	21°C	39.16%
3	Fresh Air (Standard Heat Recovery Units) SA	15.68°C	73.57%
4	<b>Fresh Air (Heat Pump Heat Recovery Units) SA</b>	<b>35.56°C</b>	<b>17.87%</b>

# DESIGN

## 01 EC Fans

To save energy and meet the ERP2018 standard, it's built with the forward EC motors with 0-10 Voltage control. It has 10 speeds and is featured by small vibration, low noise, energy-saving, and longer service life.

## 02 Bypass

In summer, the 100% bypass contributes to improved comfort and it is controlled automatically on the basis of the measured outdoor temperatures.

## 03 Multiple Filters

The standard filters are G4 and F8 grade filters. The primary filter can remove dust, pollen and other pollutants from the incoming fresh air. They also protect the heat exchanger from clogging or corrosion. And the F8 filter can further purify the air. The PM2.5 particle filtration efficiency is over 95%. An optional air disinfection filter is available for higher filtration efficiency.

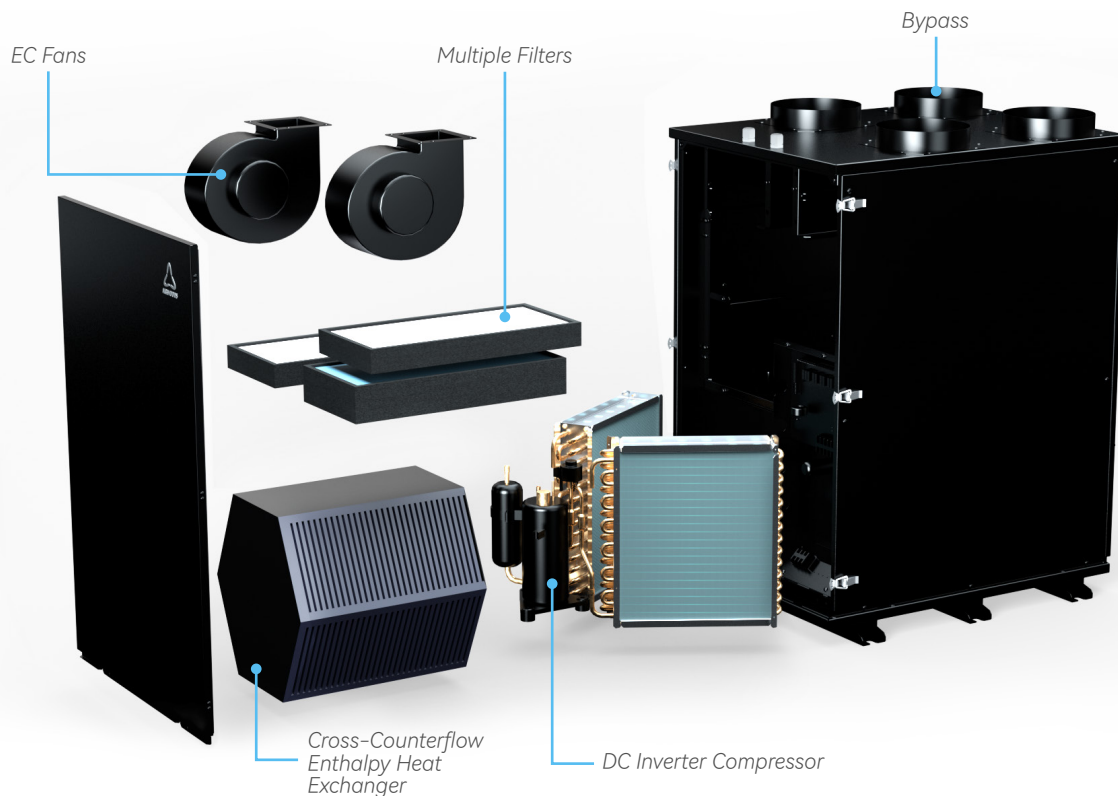

## 04 DC Inverter Compressor

It comes from the well-known brand GMCC. It compresses and expands refrigerant to transfer heat between the outdoor and indoor air streams. It is DC inverter type which can adjust its speed and output according to the load demand, ensuring energy saving performance and low noise level. It can also operate in a wide temperature range of -15°C to 50°C. Both R32 and R410a refrigerant available.

### Advantages of DC Inverter Compressor

Advantages	DC Inverter Compressor	Fix-frequency Compressor
High efficiency	√	X
Quiet operation	√	X
Longer lifespan	√	X
Smooth start-stop	√	X
Accurate and fast temperature control	√	X
Energy saving	√	X
Operation temperature	-15°C to 50°C	-7°C to 40°C

# CROSS-COUNTERFLOW ENTHALPY HEAT EXCHANGER

The cross-counterflow enthalpy heat exchanger can transfer heat and moisture between the outdoor and indoor air streams without mixing them.

It can recover up to 80% of the energy from the exhaust air, reducing the heating or cooling load on the compressor. It is washable and easy to maintain. It has a lifetime of up to 15 years.



Anti-mold & Anti-bacteria



High Strength & Stability

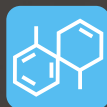

Special Polymer Membrane



Washable



Long Service Life

## ADVANTAGES

### 01 ENHANCED COMFORT THROUGH OPTIMUM INDOOR AIR QUALITY

- High efficiency with up to 90% heat recovery and up to 80% humidity recovery.
- No more dry air in winter.
- Pleasant reduction in humidity in summer.

### 02 INCREASED DURABILITY OF THE BUILDING FABRIC

A constant humidity level prevents cracks in sensitive materials such as wood flooring and extends their lifetime.

### 03 NO FROSTING UNDER - 30°C

Because of its high permeability to water molecules, no condensation water will form on the surface of the membrane, and condensation and ice blockage will not occur under extreme conditions of - 30°C.

### 04 MORE COST EFFICIENCY

Condensate-free operation under normal conditions means there is no need for a condensate drain. This saves your customers money.



ADVANCED  
LCD REMOTE  
CONTROL  
PANEL



# CONTROL & FUNCTIONS

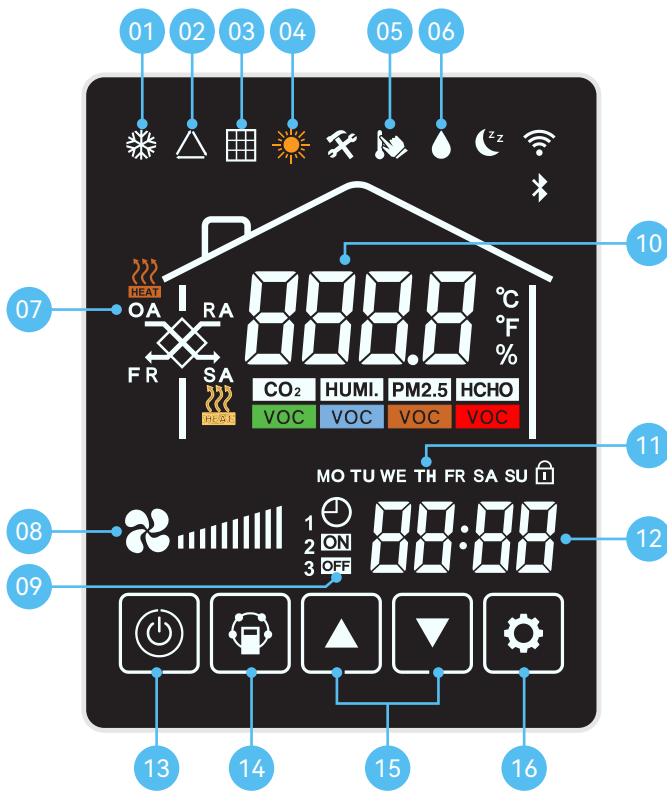

- 01. Cooling mode
- 02. Ventilation mode
- 03. Filter alarm
- 04. Heating mode
- 05. SA setting
- 06. Dehumidification mode
- 07. Temperature type
- 08. Fan speed
- 09. Weekly timer on/off
- 10. Temperature display
- 11. Week day
- 12. Clock
- 13. ON/OFF button
- 14. Mode button
- 15. Up/Down button
- 16. Set button

## WIFI FUNCTIONS

Wifi function is available to control and monitor the ventilation system from anywhere in the world using a smart phone. User can monitor the indoor air quality at your hand for healthy living.

### Monitoring Indoor Air Quality

Monitor local weather, temperature, humidity, CO<sub>2</sub> concentration at your hand for healthy living.

### Variable Setting

Timely switch, speed settings, bypass/ time/filter alarm/ temperature setting.

### Group Control

- Smart control according to local weather.
- One APP can control multiple units.
- Linkage control with other appliances with Tuya IoT.

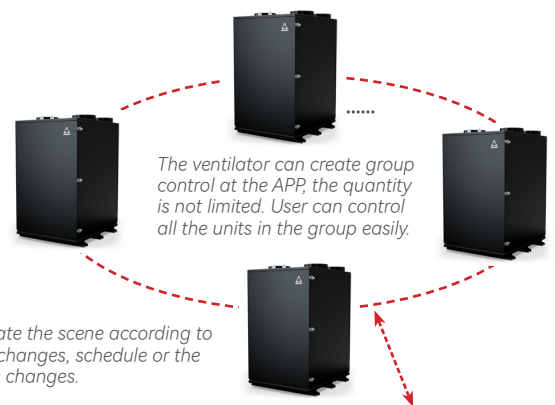

**85%** → Stop Running

For example, when the weather shows the outdoor relative humidity is higher than 85%, user can set the ventilator to stop running, to prevent the outdoor humidity coming inside. The unit will run according to the setting automatically.



# TECHNICAL PARAMETERS

\* The parameters are tested according to EN308 standards.

Model	Unit	AV-HTPF35/EI32	
Rated airflow	CMH	350	
Exhaust airflow (ventilation mode)	CMH	350	
Exhaust airflow (heating/cooling mode)	CMH	350	
External static pressure	Pa	100	
Noise	dB(A)	37/42	
Power		220V 1P 50/60Hz	
Dimension (L×W×H)	mm	760×600×1000	
Air inlet/outlet diameter	mm	188	
Air inlet/outlet height	mm	60	
Machine base height	mm	61.5	
Drainage pipe	Inch	1/2"	
Refrigerant		R32	
Operation temperature	°C	-15~50	
Ventilation mode	Temperature Effi. (heating)	%	76.5
	Temperature Effi. (cooling)	%	72
	Enthalpy Effi. (heating)	%	72.6
	Enthalpy Effi. (cooling)	%	69.4
	Input power	W	185
	Input current	A	1.08
Cooling/Heating	Norminal cooling capacity	W	3798
	Max cooling capacity	W	4173
	Input power (cooling)	W	847
	Operation current (cooling)	A	4.42
	Norminal heating capacity	W	4604
	Max heating capacity	W	4981
	Input power (heating)	W	790
	Operation current (heating)	A	3.82

## Performance Chart

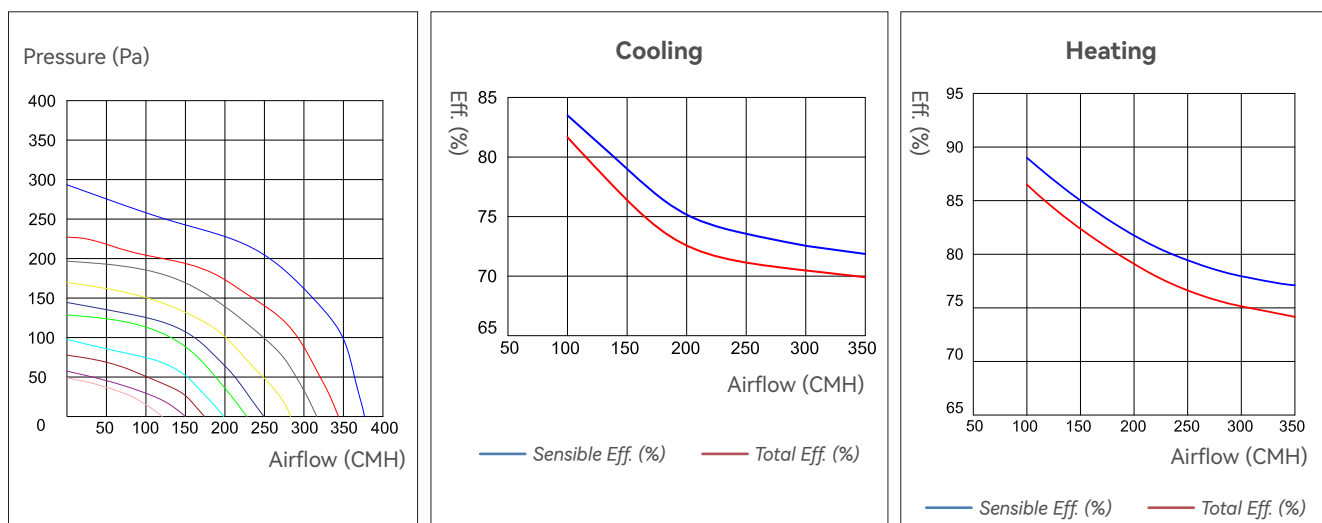

# ECO-DESIGN INFORMATION

According to Commission Regulation (EU) 1254/2014.

Model	AV-HTPF35/EI32
Energy class-Averag	A
Specific energy consumption-Average (KWh/m <sup>2</sup> .a)	-38.85
Specific energy consumption-Cold (KWh/m <sup>2</sup> .a)	-82.68
Specific energy consumption-Warm (KWh/m <sup>2</sup> .a)	-13.73
Maximum internal and external leakage rates (%)	< 5% Internal, < 5% External
Visual filter warming	Timer
The annual electricity consumption (AEC) (kWh electricity/a)	2.80
The annual heating saved-Average (KWh primary energy/a)	45.84
The annual heating saved-Cold (KWh primary energy/a)	89.68
Electric power input of the fan drive at maximum flow rate (W)	185 (Ventilation mode)
The annual heating saved-Cold (KWh primary energy/a)	20.73
Reference flow rate (m <sup>3</sup> /s)	0.10
Reference pressure difference (Pa)	100
Specific power input (SPI) {W/(m <sup>3</sup> /h)}	0.53
Control factor	0.65
Type control system	Local demand control
Type of airflow	DF
Type of motor	EC motor
Type of heat recovery system	Recuperative
Thermal efficiency of heat recovery (%)	76.5
Maximum flow rate (m <sup>3</sup> /h)	350
Sound power level dB(A)	37

## Dimensions

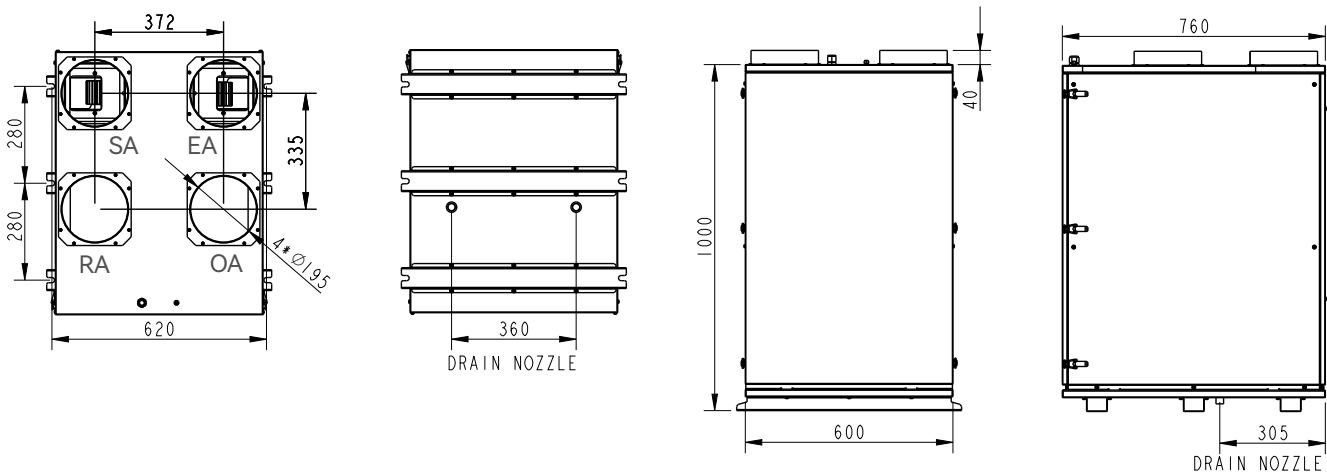

# OTHER ACCESSORIES

## Optional Preheater for Intelligent Defrosting

When the outdoor air is low than  $-15^{\circ}\text{C}$  in winter, it's recommended to use the preheater. The intelligent frost protection with preheater guarantees the high efficiency at extremely low outdoor temperatures. Compared to other solutions for frost protection, it means extra savings on the energy bill.



Model	Rated Airflow (m <sup>3</sup> /h)	Power Consumption (kw)	Heating Power (kw)	Temp. Rise (°C)	Current (A)	Volt (V)	Frequency (Hz)	Size L×W×H (mm)	Connected Air Duct Diameter (mm)
AS-EC35-1	350	1.1	1	10	4.68	230	50	350×250×250	144

## Optional IAQ Module

The wireless IAQ module can communicate with the touch screen control panel of HPERV with zigbee signal sensing indoor air quality and transmitting data to the control system, which will subsequently control the ERV to maintain good indoor air quality.



### Features:

1. Free installation, no wiring, no code matching.
2. Sensing the air quality of the user's living space in real-time.
3. An ERV maximum connected with 15 IAQ sensors.
4. Zigbee networking, long transmission distance, more stable data.
5. Micro USB 5V DC power supply, mobile phone charger can supply power.
6. Linked with APP to achieve more intelligent control.

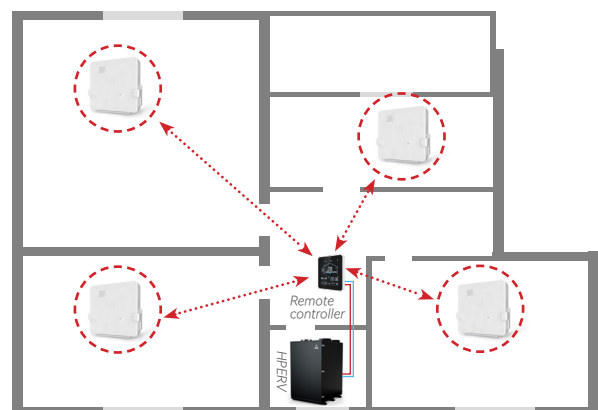

# Optional DP Technology Disinfection Filter

## DP Technology Disinfection & Sterilization



Protecting Health



DP TECHNOLOGY USES POSITIVE POLARITY TO CAPTURE, INACTIVATE, AND ERADICATE VIRUSES, BACTERIA, MOLDS, FUNGI, AND POLLENS.

DP Technology is a plant-based material that has been approved safe by the World Health Organization and the Food and Agriculture Organization of the United Nations.

Patented sterilization technology  
In the United States



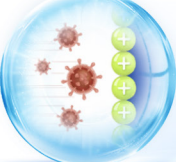

**1. Capture**  
The negatively-charged virus, microorganism, and pollen is attracted via DP Technology's positive polarity and captured upon contact.

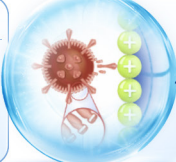

**2. Inactivate**  
The negatively-charged virus, microorganism, and pollen is inactivated as DP Technology tears away the envelope and breaks the protein membrane.

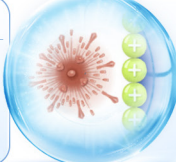

**3. Eliminate**  
Consequently, the protein envelope and protein membranes are then disintegrated, eradicating the virus, microorganism, and pollen.

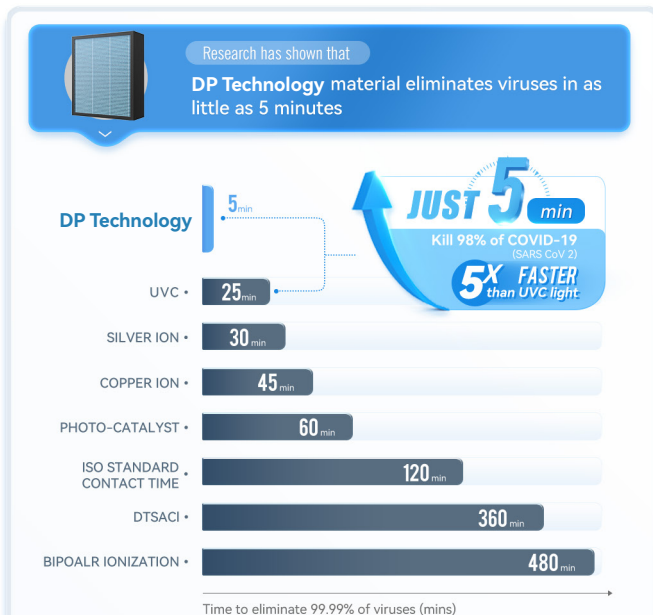

Air purification system with DP Technology filter protection  
- Superior to other similar products -

Filtration system / Item	DP Technology	HEPA	UVC	ISO IONIZATION
Captures Viruses Microorganisms And Pollens*	✓	✓	X	X
Eradicates Viruses Microorganisms And Pollens*	✓	X	✓ Takes longer time, less effective in fast airflow environments	X A study showed limited reductions.
Investment costs	LOW	LOW	LOW	HIGH
Maintenance costs	LOW	LOW	MIDDLE UVC lights have a short service life and cause system components to age more quickly.	HIGH High voltage system need to maintain every two years with high costs
Safety	HIGH WHO and UN FAO-approved food additive.	MIDDLE Residual biofouling of filters may lead to second ary contamination	HIGH Direct exposure easily causes cancer and eye damage, as well as accelerated filter degradation.	LOW May emit ozone, which is harmful to the lungs and increases harmful VOCs.

\* Based on third-party studies, commercial installations, and internal testing.

**Virus Aerosol Removal**  
**Rapid Sterilization & Disinfection**

Coronavirus, Bacterial Virus, Sterilization & Disinfection, H1N1 virus

**UP TO 99.99%**  
kill rate for multiple viruses

**Eliminating Bacterial Rate**

H1N1 virus	E. coli	Human Coronavirus 229E	Pseudomonas aeruginosa
99.99%	99.99%	99.8%	99.99%
Coxsackievirus B6	H3N2 virus	COVID-19	Candida albicans
99.99%	99.99%	99.6%	99.99%
Pseudomonas aeruginosa	Aspergillus Eliminating	Staphylococcus albicans	Staphylococcus aureus
99.99%	99.99%	99.99%	99.99%

\* The above data were provided by research institutes or laboratories around the world, including Harvard Medical School, Tampere University, Academy of Sciences of the Czech Republic, Beijing Gyeonggi Analytical and Testing Center, Fourth Affiliated Hospital Laboratory of Nanchang University, City University of Hong Kong, etc.

Official Certification  
Authoritative Testing



# APPLICATIONS

It offers air volume of 300 cubic meters per hour, which can meet the ventilation needs of 80-150 m<sup>2</sup> residential houses, villa, hotel, office etc.

If you are fed up with limited space in the house by adding traditional ventilation unit, dehumidifier, air purifier, split type heat pump etc, let's try one DC inverter fresh air heat pump system. It is available to install in the attic, basement, cabinet in the kitchen etc which take up limited space.

## How to select the right model for your house?

1. Calculation of airflow according to air exchange rate.

$$L = V_{\text{prem.}} \times \text{Ach} \text{ (m}^3\text{/h)},$$

where **V prem.** – premise volume (m<sup>3</sup>),

**Ach** – minimum air exchange per hour, refer air exchange table.

Premise	Air exchange rate	
Domestic premises	Living room of apartments or hostel residential premises	3 m <sup>3</sup> /h for 1 m <sup>2</sup> in residential premises
	Kitchen in flat or hostel	6-8
	Bathroom	7-9
	Shower cabin	7-9
	WC	8-10
	Home laundry room	7
	Cloakroom	1.5
	Storeroom	1
	Garage	4-8
	Cellar	4-6

2. Calculation of airflow according to number of inhabitants.

$$L = L1 \times NL \text{ (m}^3\text{/hour)},$$

where **L1** – rated value for air volume per one person, m<sup>3</sup>/h\*person,

**NL** – number of inhabitants in the premises.

20-25 m <sup>3</sup> /h per one person at low physical activity
45 m <sup>3</sup> /h per one person at light physical activity
60 m <sup>3</sup> /h per one person at heavy physical activity



3. Choose the bigger result as the required airflow. Then choose the model with the required airflow accordingly.

The heat pump energy recovery ventilator should be used priority to supply fresh air then to do the air conditioning.



**GUANGZHOU AIRWOODS ENVIRONMENT TECHNOLOGY CO., LTD.**

2101, Tower 25 Headquarter Center,  
Tian An Park, 555 Panyu Ave., Guangzhou, China

T: +86-20-39141701

E: [info@airwoods.com](mailto:info@airwoods.com)

W: [www.airwoods.com](http://www.airwoods.com)

