



Aluminum Roller Shutter Window & Door Systems

Custom Solutions for Residential,
Commercial & Industrial Applications

Your Reliable Aluminum Roller Shutter Partner

Integrated manufacturing support for aluminum roller shutter window and door systems

We supply aluminum profiles and related solutions for roller shutter window and door systems, helping customers build competitive products for residential, commercial and industrial markets.

With support in profile customization, production coordination, surface finishing and export delivery, we work closely with project buyers, wholesalers and OEM customers for long-term cooperation.

Security • Weatherproof • Quiet Operation • Custom Made

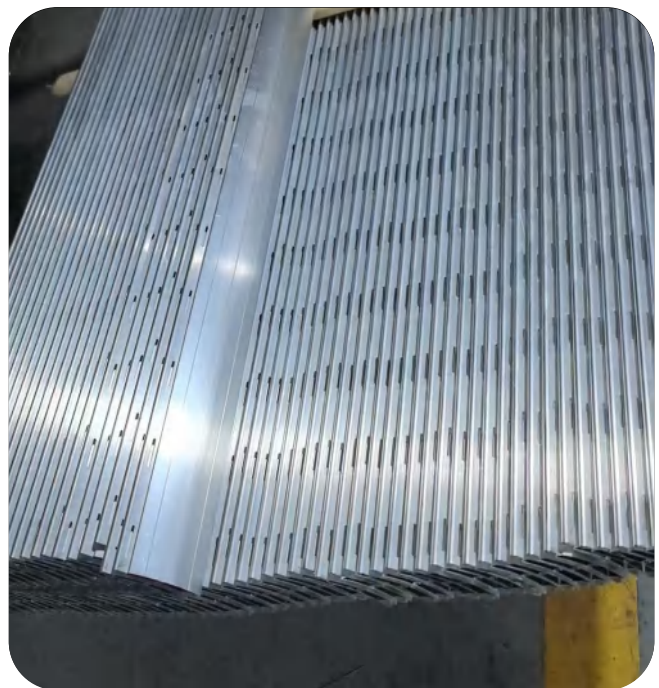

Profile System Support



Custom Manufacturing



Stable Quality Control



Export Project Experience

Why Choose Aluminum Roller Shutter Systems



1. Security Protection

Enhances safety for homes, shopfronts, garages and warehouse openings.



2. Privacy Control

Improves privacy for windows, doors and street-facing spaces.



3. Heat & Sunlight Reduction

Helps reduce strong sunlight and supports better indoor comfort.



4. Noise Reduction

Contributes to a quieter environment for residential and commercial use.



5. Weather Resistance

Suitable for outdoor use with good resistance to sun, dust and rain.

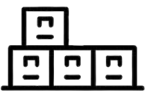

6. Modern Appearance

Combines practical performance with a neat and modern architectural style.



Product Overview

Aluminum Rolling Shutter Window & Door Systems

Aluminum rolling shutter window and door systems are designed for security, durability and practical daily use.

Made from high-strength aluminum profiles, they offer reliable wind resistance, weather protection and anti-theft performance.

They are suitable for residential, commercial and industrial applications, with customizable sizes, finishes and colors to match different project needs.

We supply both individual aluminum profiles and complete rolling shutter system solutions.



Product Information

Item	Specification
Slat Wall Thickness	0.8 / 1.0 / 1.2 mm optional
Operation	Manual / Motorized / Remote Control optional
Slat Option	Foam-filled / Non-filled
Wind Resistance	Based on profile selection and project design
System Size	Customized width and height available
Warranty	Based on product configuration
Surface Finish	Powder coating / Anodizing / Wood grain / Customized colors
Application	Residential windows, commercial doors, garages, warehouses and industrial openings

► Roller Shutter for Windows



► Roller Shutter for Doors



► Manual Roller Shutter Systems



► Motorized Roller Shutter Systems

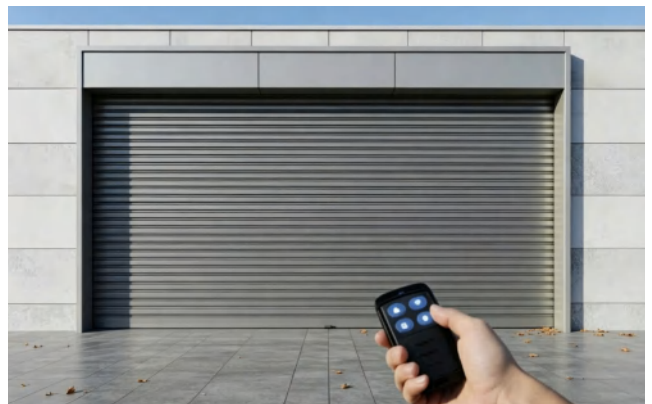

► Foam-Filled Slat Options



► Single-Wall Slat Options



System Structure

Main components of aluminum roller shutter systems

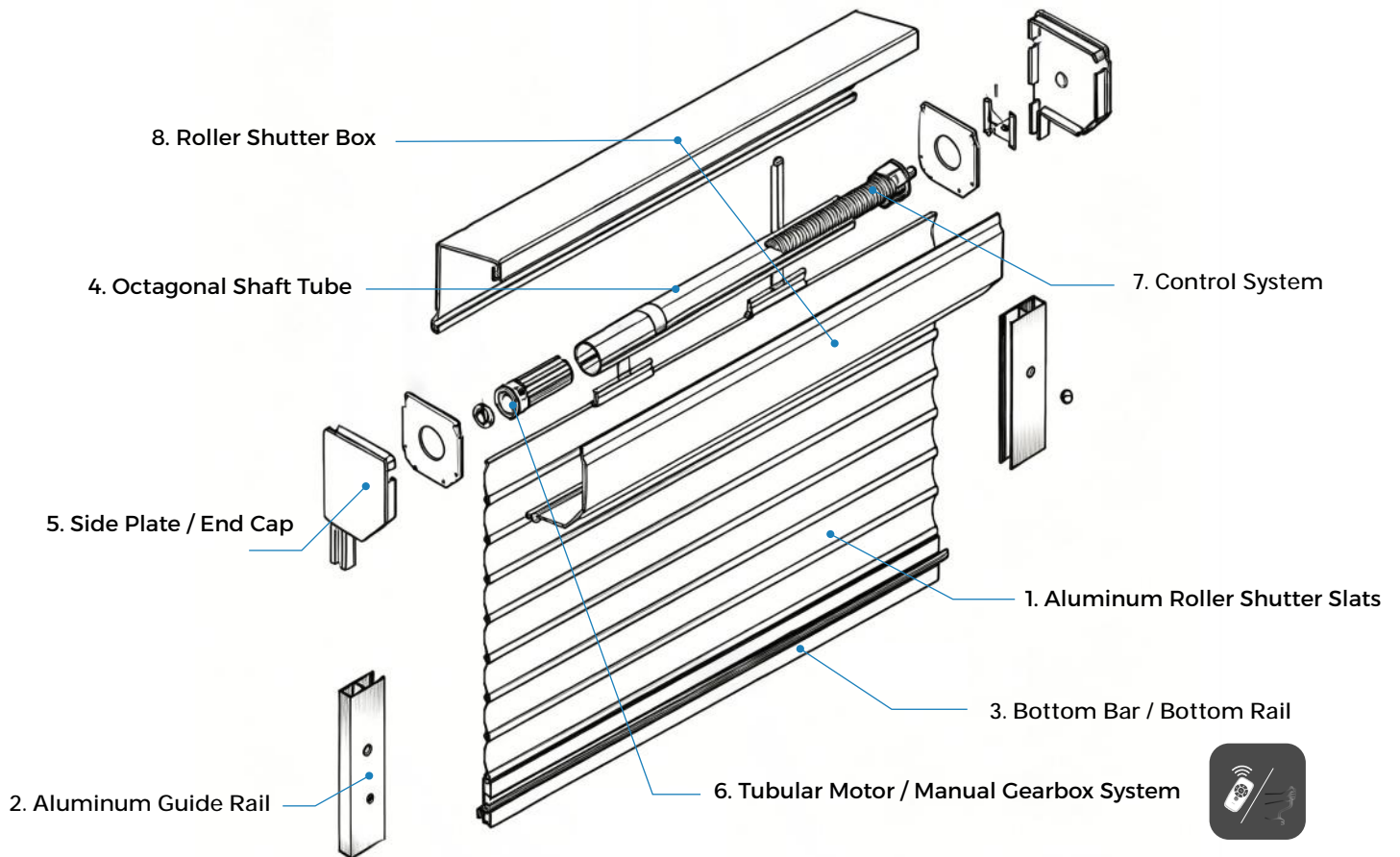

1. Aluminum Roller Shutter Slats

Forms the main shutter curtain and provides security, privacy, shading and daily protection.

2. Aluminum Guide Rail

Guides the shutter curtain smoothly up and down, helping ensure stable, quiet and safe operation.

3. Bottom Bar / Bottom Rail

Strengthens the lower edge of the shutter curtain and improves closing performance and overall stability.

4. Octagonal Shaft Tube

Supports the shutter curtain and allows it to roll up and down smoothly inside the shutter box.

5. Side Plate / End Cap

Covers and protects both sides of the shutter box, helping keep the internal components secure and neat.

6. Tubular Motor / Manual Gearbox System

Provides reliable operation for opening and closing. The system can be designed with motorized control or manual operation depending on project requirements.

7. Control System

Supports convenient operation through wall switch, remote control, smart control or other control options.

8. Roller Shutter Box

Encloses the rolled shutter curtain, shaft, motor and internal parts for protection, safety and a clean appearance.

Slat Profiles

*Surface Finish: Powder Coating / Anodizing / Wood Grain Available

*Option: Foam-filled / Non-filled

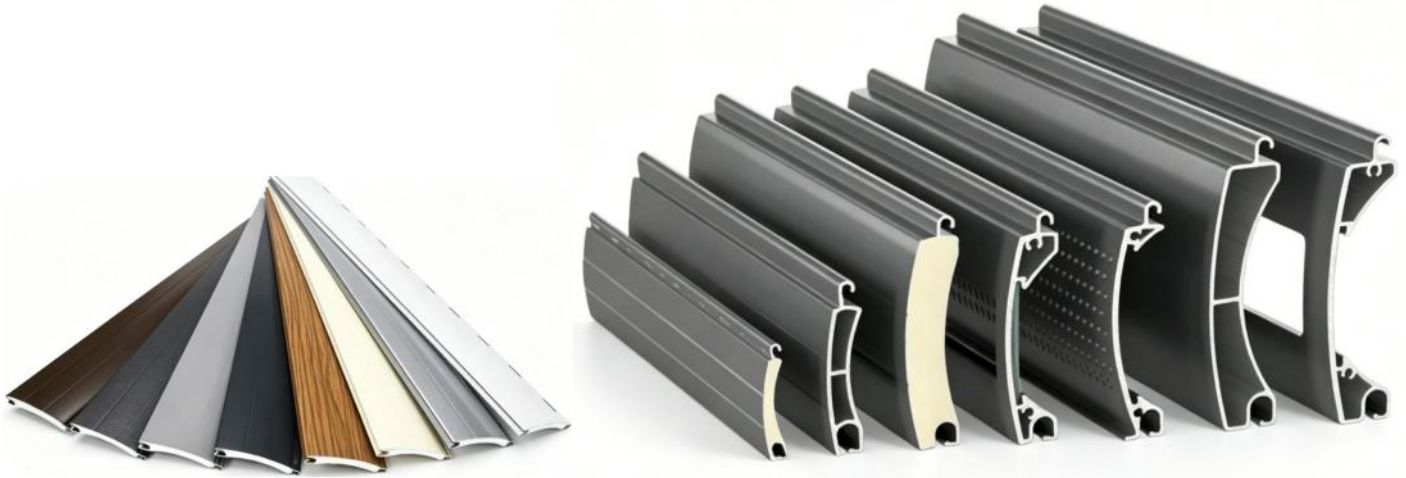

Model No. : KDL-02	Weight : 0.626kg/m
Material : Aluminum	Overall Height: 14.9 mm
Overall Width: 65.7 mm	Wall Thickness: 1.3 mm
Visible Width: 56 mm	

Model No. : DM-03A	Weight : 0.338kg/m
Material : Aluminum	Overall Height: 13.4 mm
Overall Width: 68.8 mm	Wall Thickness: 0.65 mm
Visible Width: 59.69 mm	

Model No. : DM-03	Weight : 0.382kg/m
Material : Aluminum	Overall Height: 13.4 mm
Overall Width: 68.8 mm	Wall Thickness: 0.8 mm
Visible Width: 59.69 mm	

Model No. : DM-04	Weight : 0.391kg/m
Material : Aluminum	Overall Height: 13.88 mm
Overall Width: 65 mm	Wall Thickness: 0.8 mm
Visible Width: 55.1 mm	

Model No. : QHM255	Weight : 0.461kg/m
Material : Aluminum	Overall Height: 13.84 mm
Overall Width: 65.5 mm	

Model No. : QHM257	Weight : 0.44kg/m
Material : Aluminum	Overall Height: 13.8 mm
Overall Width: 70.6 mm	

Model No. : QHM258	Weight : 0.323kg/m
Material : Aluminum	Overall Height: 9.1 mm
Overall Width: 48.6 mm	

Model No. : QHM259	Weight : 0.32kg/m
Material : Aluminum	Overall Height: 9.5 mm
Overall Width: 47 mm	

Model No. : QHM262	Weight : 0.277kg/m
Material : Aluminum	Overall Height: 10.1 mm
Overall Width: 53.3 mm	

Guide Rail & Bottom Bar Profiles

*Surface Finish: Powder Coating / Anodizing / Wood Grain Available

*Option: Foam-filled / Non-filled



► Guide Rail Profiles

Model No. : KDL-03	Weight : 1.35kg/m
Material : Aluminum	Overall Height: 30.3 mm
Overall Width: 76.4 mm	Inner Slot Width: 20.7 mm
Wall Thickness: 2.2 mm	Suitable Slat Height: 77 mm

Model No. : DM-02A	Weight : 1.018kg/m
Material : Aluminum	Overall Height: 27.3 mm
Overall Width: 75.8 mm	Inner Slot Width: 19.3 mm
Wall Thickness: 1.7 mm	

Model No. : DM-02	Weight : 0.338kg/m
Material : Aluminum	Overall Height: 27.3 mm
Overall Width: 75.8 mm	Inner Slot Width: 19.3 mm
Wall Thickness: 0.65 mm	

► Bottom Bar Profiles

Model No. : DM-01	Weight : 0.449kg/m
Material : Aluminum	Overall Height: 12 mm
Overall Width: 65 mm	
Wall Thickness : 1.0mm	

Model No. : QHM254	Weight : 0.413kg/m
Material : Aluminum	Overall Height: 10 mm
Overall Width: 62.5 mm	

Model No. : QHM256	Weight : 0.284kg/m
Material : Aluminum	Overall Height: 8 mm
Overall Width: 50 mm	

Model No. : QHM260	Weight : 0.155kg/m
Material : Aluminum	Overall Height: 8.51 mm
Overall Width: 29.7 mm	

Model No. : QHM261	Weight : 0.14kg/m
Material : Aluminum	Overall Height: 8.4 mm
Overall Width: 29.4 mm	

Model No. : KDL-04	Weight : 0.511kg/m
Material : Aluminum	Overall Height: 10.3 mm
Overall Width: 64.7 mm	
Visible Width: 55.5 mm	

Other Main Aluminum Profiles

► Cover Box Profiles



► Mounting Brackets



► Roller Shutter Accessories



Foam-filled Slat Option

- ▶ Better thermal insulation

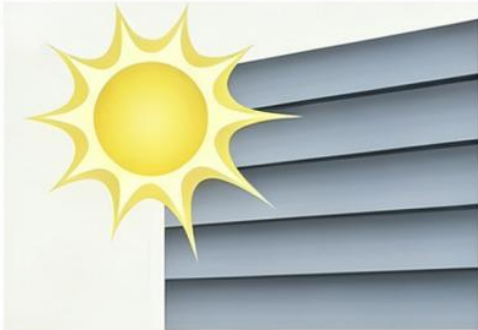

- ▶ Improved noise reduction

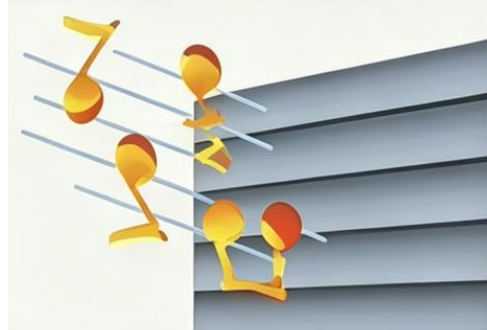

- ▶ Smoother daily operation



- ▶ Suitable for residential and light commercial use



- ▶ Balanced strength and weight

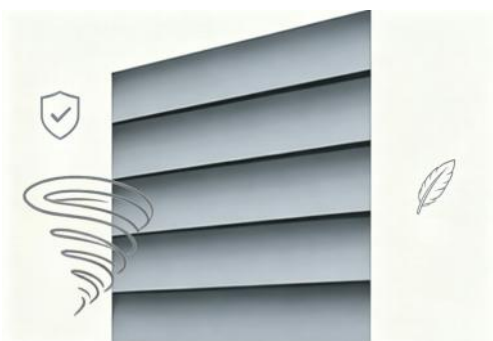

Foam-filled slats are recommended for residential windows, villa projects and light commercial roller shutter applications where insulation and quiet operation are required.

Operation Options

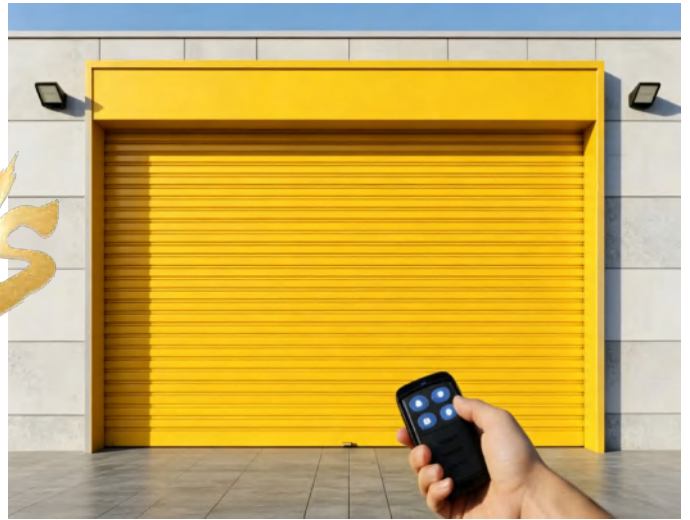

Manual System

Cost-effective

Suitable for small openings

Crank / spring operated

Motorized System

More convenient

Suitable for larger openings

Remote / switch / smart control



Motors, Controls & Accessories

▶ Tubular Motor



▶ Remote Controller



▶ Wall Switch



▶ Remote Control / Wall Switch / Smart Control Available



▶ End Caps

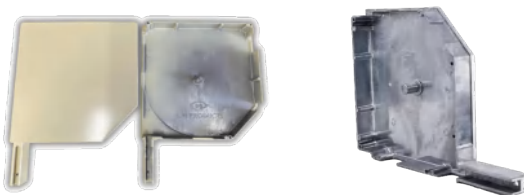

▶ Guide Rail Accessories



▶ Bottom Seal / Rubber



▶ Side Plates / Support Brackets



Surface Finish & Color Options



Custom RAL Colors

Standard colors: White, Black, Grey, Beige, Silver, Bronze.

Custom RAL colors and wood grain finishes are available upon request.



Powder Coating

Anodized Finish



Wood Grain Finish

Applications for Windows



► Street-facing Windows



► Privacy & Sun Protection Projects



► Apartment Buildings



► Residential Windows



► Villas

Applications for Doors

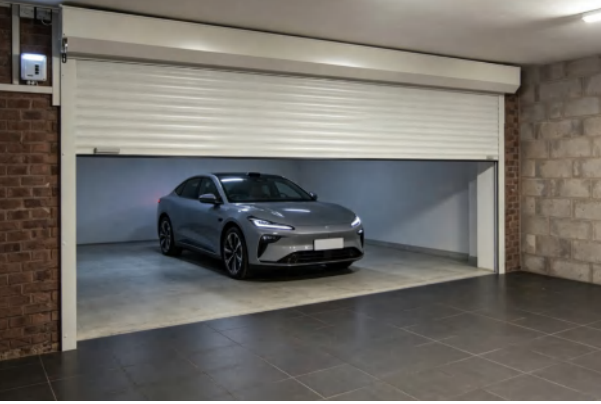

► Garage Doors



► Industrial Entrances



► Warehouse Openings



► Commercial Shopfronts



► Security Door Openings

Customization Capability

Flexible aluminum roller shutter solutions for different project requirements

What We Can Customize

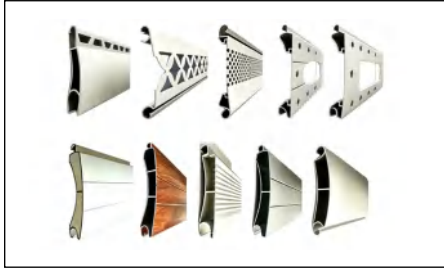

► Custom Slat Profiles



► Custom Sizes



► Different Thickness Options



► Surface Finish Customization

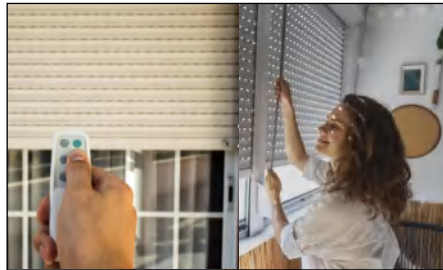

► Manual / Motorized Configuration

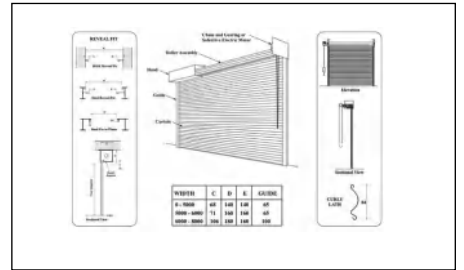

► OEM / ODM Support



► Project-based Solutions

How We Work

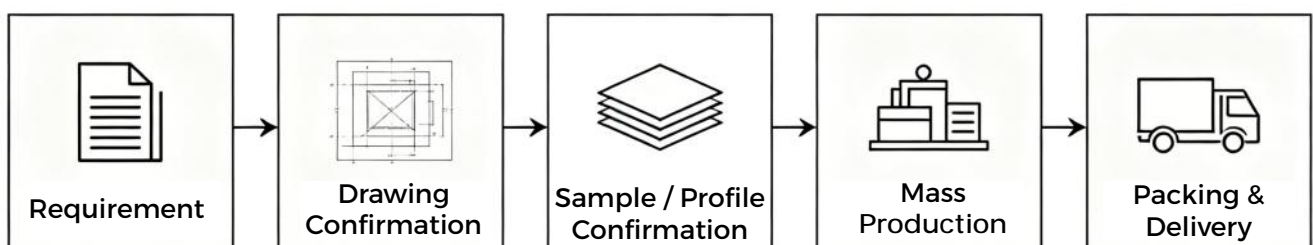

Production & Quality Control

1. Raw Material Inspection



2. Profile Extrusion & Forming



3. Surface Treatment



4. Assembly & Function Check



5. Packaging Inspection



6. Shipment Preparation



Packing & Delivery

Standard export packing

Protective film

Carton / wooden box options



Container loading

Export support

Fast quotation response

*** Packing method can be adjusted according to order quantity, profile length, surface finish and shipping method.

Let's Discuss Your Project

Send us your size, drawing,
quantity or market requirements for a fast quotation.

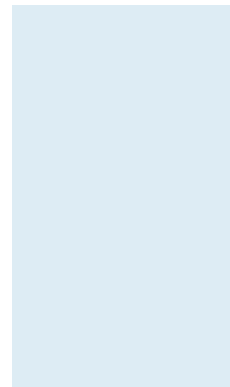

Company Name: **Company Name: Foshan Yaoxing Aluminum Co., Ltd.**

Contact Person: Carmen

Email: sales@yx-aluminum.com

WhatsApp: +86-133 3641 2162

Website: www.yx-aluminum.com

Factory Address: Xinghong Road, Shishan Town, Foshan City, Guangdong, China

