

# Y2SD2-ECX

## EtherCAT Bus Stepper Driver

### User Manual



Guangdong Kaifull Electronics Technology Co., Ltd.

<http://www.kaifull.net/>

# Contents

<b>1. FOREWORD .....</b>	<b>3</b>
1.1 OVERVIEW .....	3
1.2 TECHNICAL SPECIFICATIONS .....	3
<b>2. PREPARATION .....</b>	<b>4</b>
2.1 POWER SUPPLY SELECTION .....	4
2.2 MOTOR SELECTION .....	4
<b>3. INSTALLATION .....</b>	<b>5</b>
3.1 SERVICE ENVIRONMENT .....	5
3.2 MECHANICAL DIMENSIONS .....	5
<b>4. CONNECTION .....</b>	<b>6</b>
4.1 DEFINITIONS OF DRIVER INTERFACES .....	6
4.2 INPUT PORT CONNECTION .....	7
4.3 OUTPUT PORT CONNECTION .....	8
4.4 POWER CONNECTION .....	9
4.5 MOTOR .....	9
4.6 ETHERCAT COMMUNICATION CONNECTION .....	9
4.7 ETHERCAT NETWORK INDICATOR LIGHT .....	9
4.8 SETTING ETHERCAT STATION ADDRESS .....	9
<b>5. MOTION CONTROL .....</b>	<b>10</b>
5.1 ETHERCAT CONTROL MODE .....	10
5.2 COE OBJECT DICTIONARY DESCRIPTION .....	11
<b>6. HOMING METHOD .....</b>	<b>13</b>
METHOD 17: .....	13
METHOD 18: .....	13
METHODS 19 AND 20 .....	14
METHODS 21 AND 22 .....	15
METHODS 23, 24, 25 AND 26: .....	16
METHODS 27, 28, 29 AND 30: .....	17
METHODS 33 AND 34 .....	18
METHODS 35, 37: .....	18
<b>7. ALARM .....</b>	<b>19</b>
7.1 ERROR CODE .....	19
<b>8. CONTACT KAIFULL .....</b>	<b>20</b>

# 1. Foreword

## 1.1 Overview

The Y2SD2-ECX open-loop bus stepper driver perfectly integrates advanced motion control technology into the stepper motor to greatly expand the functions of EtherCAT, with new excellent performance and a wide range of applications. Equipped with the EtherCAT communication protocol, the driver can serve as a standard EtherCAT slave and support CANopen over EtherCAT (CoE); it can also be used with various open-loop stepper motors with different sizes.

EtherCAT® is a registered trademark and patented technology authorized by Beckhoff Automation Co., Ltd.

## 1.2 Technical Specifications

Input power voltage	24~48VDC
Output current	0.1~6.0A (peak)
Matching motor	20~86 open-loop stepper motor
Digital input signal	Optoelectronic isolation, differential, 5-24VDC high-level logic Home position signal, positive limit, negative limit, emergency stop, probe
Digital output signal	Optoelectronic isolation, open collector, maximum 24V/100mA Brake output, alarm output, in-place output
Communication interface	EtherCAT (RJ45 connector) and Type-C (for configuring)
Supported protocol	CoE (CiA 402 Protocol)
Operation mode	Profile Position, Profile Velocity, Cyclic Synchronous Position, Cyclic Synchronous Velocity, Homing mode
Electrical protection	Overvoltage protection, undervoltage protection, overtemperature protection, overcurrent protection, motor line open circuit detection, etc.
Status indication	1 red LED light and 1 green LED light
Mass	0.233Kg

## 2. Preparation

### 2.1 Power Supply Selection

The supply voltage of the driver shall work normally within the specified range. To make the motor provide better high-speed performance, the supply voltage of the driver needs to be increased.

The supply current is generally determined based on the output phase current of the driver. Normally, the supply current of the driver can be 1.1 to 1.3 times the output current of the driver.

Meanwhile, the magnitude of the input current of the power supply is also related to the speed and load of the motor during operation. Therefore, for specific application scenarios, users need to make specific analysis and estimation.

### 2.2 Motor Selection

Y2SD2-ECX can output a maximum current of 6A and is suitable for two-phase DC stepper motors with flange sizes of 86 and below.

The selection of stepper motors must be determined based on the calculation according to the load of relevant mechanisms. You can contact Kaifull's hotline (400-960-1069) to inquire about the specific method of motor selection!

### 3. Installation

#### 3.1 Service environment

Scenario	Avoid the sites with dust, oil mist, corrosive gases, high humidity, and strong vibration. Keep away from combustible gases and conductive dust, and maintain natural or forced air cooling;
Ambient temperature	0~50°C
Ambient humidity	40~90%RH
Vibration	10~55Hz/0.15m
Storage temperature	-20°C~65°C

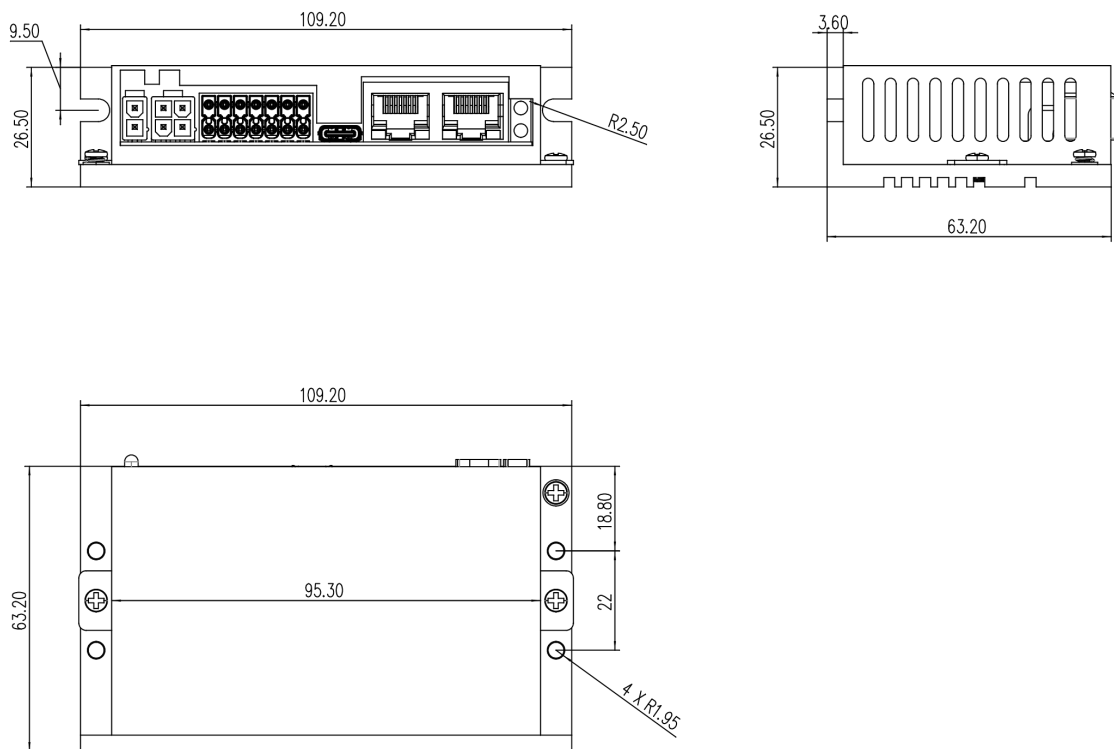

#### 3.2 Mechanical Dimensions



\*It is recommended to install vertically on the side to create strong air convection through the heat dissipation teeth. If necessary, install a fan near the driver to force heat dissipation and ensure that the driver operates within a reliable temperature range.

## 4. Connection

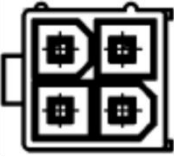
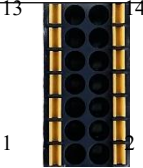
### 4.1 Definitions of Driver Interfaces

CN1：供电电源输入		CN3: Digital input/output		
CN1.1	GND	CN3.1	IN1+	Digital input 1 positive pole
CN1.2	V+ (24~48V)	CN3.2	IN1-	Digital input 1 negative pole [probe 1]
2 V+ 1 GND 		CN3.3	IN2+	Digital input 2 positive pole [connected to+24V]
		CN3.4	IN2-	Digital input 2 negative pole [home position]
		CN3.5	IN3+	Digital input 3 positive pole [connected to+24V]
		CN3.6	IN3-	Digital input 3 negative pole [positive limit]
<b>CN2：马达连接</b> CN2.1 马达线 B- CN2.2 马达线 A+ CN2.3 马达线 B+ CN1.4 马达线 A- 3 B+ 1 B- 4 A- 2 A+ 		CN3.7	IN4+	Digital input 4 positive pole [connected to+24V]
		CN3.8	IN4-	Digital input 4 negative pole [negative limit]
		CN3.9	OUT1	Digital output 1
		CN3.10	COMO	Digital output COM
		CN3.11	BR+	Power-off brake output 24V+
		CN3.12	BR-	Power-off brake output 0V
		CN3.13	24VB	Power-off brake supply input+24V
		CN3.14	GND	Power-off brake supply input 0V
CN4: PC debugging interface				
Use USB TYPE-C connecting cable to connect to computer debugging software				
 Type-C				

## 4.2 Input port connection

- IN1: Differential, NPN, PNP; can directly receive 5-24VDC at high level; default to probe 1 function input
- IN2: Differential, NPN, PNP; can directly receive 5-24VDC at high level; default to home position signal input
- IN3: Differential, NPN, PNP; can directly receive 5-24VDC at high level; default to positive limit signal input
- IN4: Differential, NPN, PNP; can directly receive 5-24VDC at high level; default to negative limit signal input
- IN1-IN4 can be used as general inputs, and the input port functions can be configured using the KF Step Drive Configuration debugging software, such as positive and negative limits, home position, enabling and alarm clearing, etc. IN1 and IN2 can be used as input ports for probes 1 and 2, respectively.
- Common wiring methods for each input port are listed below

IN1、IN2、IN3、IN4:



NPN signal connection method



PNP signal connection method

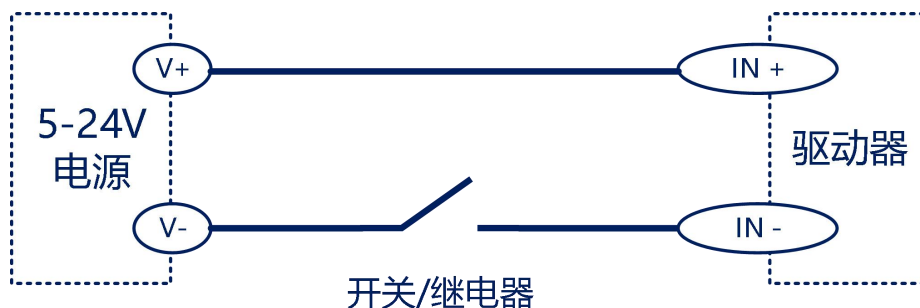

开关/继电器

Switch or relay connection method

### 4.3 Output port connection

- OUT1: Optoelectronic isolation, single end, default normally on, maximum output current 100mA
- OUT1 can be used as general output, and the output port function can be configured using the KF Step Drive Configuration debugging software, such as in-place output and alarm output.

The following are common wiring methods for output port: OUT1:

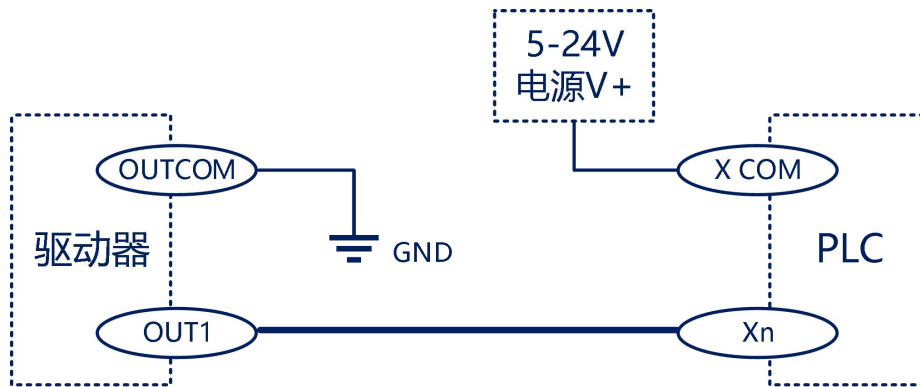

NPN output wiring method

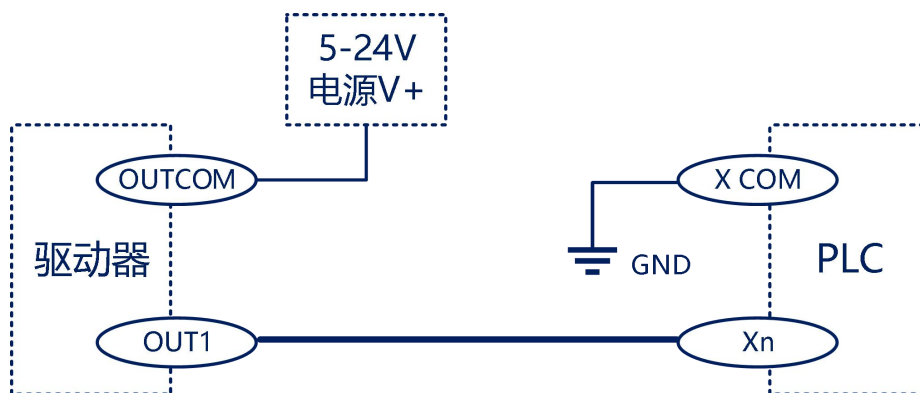

PNP output wiring method

## 4.4 Power Connection

Connect the positive pole of the power supply to the V+ of the driver and the negative pole of the power supply to the V - of the driver.

**\*Please note that the positive and negative terminals of the power supply should not be connected reversely. Otherwise, it may cause the drive to burn out.**

## 4.5 Motor

Connect the A+, A-, B+, and B- of motor outgoing line to the MA+, MA-, MB+ and MB- of the motor connector CN2 on the driver in sequence (or according to the sequence of black, green, red and blue).

**Note: Do not damage or forcefully pull the outgoing lines of motor, and do not subject the outgoing lines to the excessive force (e.g., lifting the motor with the lines), place them under heavy objects or make them clamped.**

## 4.6 EtherCAT communication connection

The dual-port RJ-45 connector is a 100BASE-TX (100Mbps) compliant interface that can be connected using the standard network cable. Please use CAT5 or CAT5e (or higher-level) network cable. The Ethernet input interface IN is connected to the Ethernet output interface OUT of the previous driver on the controller or bus. The Ethernet output interface OUT is connected to the Ethernet input interface IN of the next driver on the bus. If the driver is the last node on the bus, only the Ethernet input interface IN needs to be connected. The terminal matching resistor does not need to be used.

## 4.7 EtherCAT network indicator light

The indicator lights are used to display the status of EtherCAT, with a total of four status lights: RUN, ERR, Link/Activity In, and Link/Activity Out.

## 4.8 Setting EtherCAT station address

The EtherCAT site address of the driver can be written in the Kaifull configuration software or assigned by the PLC host. The main station can set the 0004h address from the station to the SII (Slave Information Interface) EEPROM. Once the driver is powered on, it can obtain the numerical value from the 0004h of SII to set the station address.

The indicator lights are used to display the status of EtherCAT, with a total of four status lights: RUN, ERR, Link/Activity In, and Link/Activity Out.

## 5. Motion Control

### 5.1 EtherCAT Control Mode

Y2SD2-ECX supports both synchronous and asynchronous modes. In synchronous motion mode, the master station performs trajectory planning and outputs cycle instructions. The driver receives the planning instructions from the master station according to the synchronization cycle, making it suitable for multi-axis synchronous motion.

Y2SD2-ECX synchronous motion mode supports cyclic synchronous position

mode (CSP). In the cyclic synchronous position mode (CSP), trajectory planning is completed at the master station. The position information sent by the master station is received based on the synchronization cycle, and the position information is immediately transmitted to the driver when the synchronization signal arrives. The synchronization cycles supported by Y2SD2-ECX include: 1000 us, 2000 us and 4000 us.

Control Mode	Index + Sub-index	Name	Data type	Access type	Unit	PDO configuration	SDO communication
CSP mode (8)	6040-00h	Control word	U16	RW	—	Must	-
	607A-00h	Target position	I32	RW	P	Must	-
	6041-00h	Status word	U16	RO	—	Must	-
	6064-00h	Actual position	I32	RO	P	Must	-
	606C-00h	Actual speed	I32	RO	P/S	Can	Can
PP mode (1)	607A-00h	Target position	I32	RW	P	Recommended	Can
	6081-00h	Target speed	U32	RW	P	Can	Can
PV mode (3)	60FF-00h	Target speed	I32	RW	P	Recommended	Can
Shared by PP mode (1) and PV mode (3)	6040-00h	Control word	U16	RW	—	Recommended	Can
	6083-00h	Acceleration	I32	RW	P/S <sup>2</sup>	Can	Can
	6084-00h	Deceleration	U32	RW	P/S <sup>2</sup>	Can	Can
HOME mode (6)	6040-00h	Control word	U16	RW	—	Recommended	Can
	6098-00h	Zeroing method	I8	RW	—	Can	Can
	6099-01h	Home position fast	U32	RW	P/S	Can	Can
	6099-02h	Home position slow	U32	RW	P/S	Can	Can
	609A-00h	Home position acceleration	U32	RW	P/S <sup>2</sup>	Can	Can
	607C-00h	Home position offset	U32	RW	P	Can	Can
PP, PV and HOME modes	6041-00h	Status word	U16	RO	—	Recommended	Can
	6064-00h	Actual position	I32	RO	P	Recommended	Can
	606C-00h	Actual speed	I32	RO	P/S	Can	Can
Shared by all modes	60B8-00h	Probe function	U16	RW	—	Recommended	Can
	60B9-00h	Probe status	U16	RO	—	Recommended	Can
	60BA-00h	Probe 1 captured value	I32	RO	P	Can	Can
	60FD-00h	Digital input	U32	RO	—	Recommended	Can
	603F-00h	Latest error code	U16	RO	P	Recommended	Can
Other associated parameters	6060-00h	Operation Mode	I8	RW	—	Can	Can
	60B0-00h	Position offset	I32	RW	—	Can	Can
	6082-00h	Jump speed	U32	RW	P/S	Can	Can
	6085-00h	Emergency stop deceleration	U32	RW	P/S <sup>2</sup>	Can	Can
	6061-00h	Operation mode display	I8	RO	—	Can	Can

## 5.2 COE object dictionary description

Object Dictionary	Sub-index	Name	Read/Write	Data size	Range	Default value	Unit	Remark
0x1010	01	Save all parameters	R/W	UDINT	0~0xFFFFFFFF	0	-	Save command: 0x65766173 Decimal system: 1702257011 Return to 1 after saving successfully
0x1011	01	Restore all parameter factory	R/W	UDINT	0~0xFFFFFFFF	0	-	Recovery command: 0x64616f6c Decimal system: 1684107116 Return to 1 after factory reset
0x2000	00	Peak current	R/W	DINT	0~8000	800	mA	Set to the rated current of the stepper motor, in milliamperes.
0x2001	00	Subdivision number	R/W	DINT	400~51200	4000	Pulse	Motor pulses per revolution, effective upon restart
0x2002	00	Minimum current	R/W	DINT	0~8000	500	mA	Set to 50% of the rated current of the stepper motor, in milliamperes.
0x2003	00	Open loop/closed-loop control mode	R/W	DINT	0~16	0	-	8: Open loop mode 0: Closed loop mode
0x2007	00	Brake control mode	R/W	DINT	0~1	0	--	0: Brake function enabled 1: Brake function disabled
0x2008	00	Driver startup scanning current	R/W	DINT	0~7000	1500	mA	In the open-loop mode, the driver will be started to initiate the phase search scanning current and will be set to the rated current of the motor. in milliamperes
0x2029	00	The number of pulses per revolution of the encoder	R/W	DINT	200~30000	4000	Pulse	The pulse count outputted by the encoder by rotating one turn. When a 1000-line encoder is used, it is set to 4000. When a 2000-line encoder is used, it is set to 8000; and so forth
0x2051	00	Motor running direction	R/W	DINT	0~1	0	-	0: Clockwise 1: Anti-clockwise

0x2058	00	Driver limit switch enabling	R/W	DINT	0~1	0	-	Driver limit switch function; when encountering a limit switch during operation, the control word will be set and the driver will stop running. 0: The internal limit switch cannot be enabled.	
0x2152	01	Motor input port IN1 Function setting  (2152.02-05 correspond to IN2-IN5 respectively)	R/W	DINT	0~1000	0	-	1	Probe 1
								2	Probe 2
								3	Home position
								4	Positive limit
								5	Negative limit
								6	Enabling control input
								7	Alarm clear input
								8	Emergency stop input
								17	General IO1
								18	General IO2
								19	General IO3
								20	General IO4
								21	General IO5
If the reverse signal needs to be taken, write the current value+128. <i>For example, ①: Defined as positive limit and reverse signal taken, written to 132. ② Defined as negative limit and</i>									
0x60FD	-	Digital input	RO	UDINT	0~0xFFFFFFFF	0	-	60FD is used to map the digital input, and the status of each bit represents the status of the digital input  Bit0:: Negative limit Bit1: Positive limit Bit2: Home position Bit26: Probe 1 Bit27: Phase Z signal	

## 6. Homing method

The Y2SD2-ECX series driver product supports multiple ways to return to the home position. The specific definition and process of returning to the home position are described as follows.

**Negative Limit:** Negative direction limit; **Positive Limit:** Positive direction limit; **Home:** Home position

### Method 17:

If the negative limit switch is not activated, the initial movement direction of motor is negative. After encountering the negative limit switch, the motor will decelerate and run reversely, and the home detection position is the position where the negative limit switch status changes.

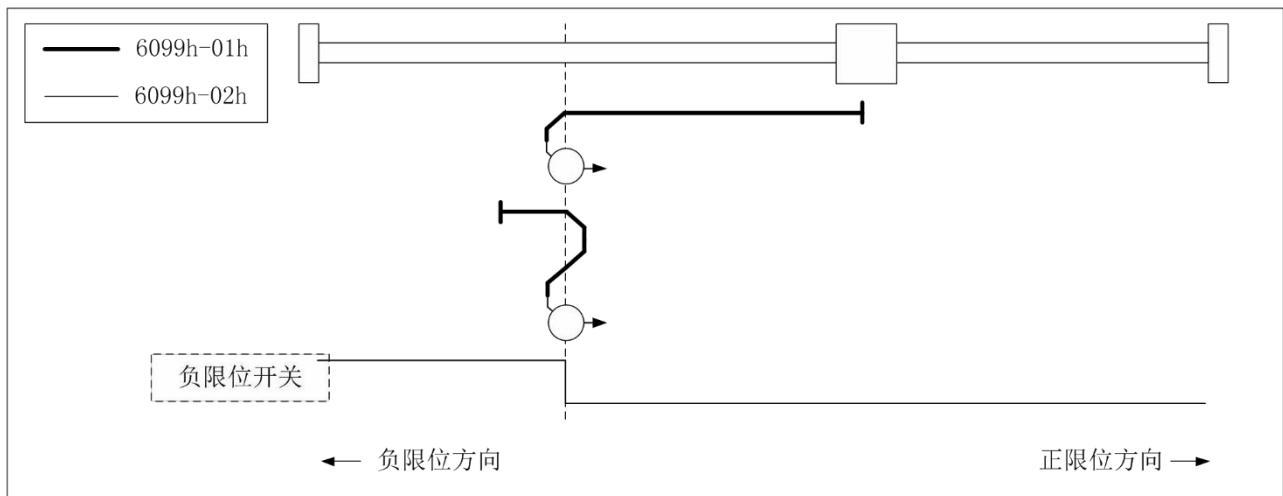

Method 17 diagram

### Method 18:

If the negative limit switch is not activated, the initial movement direction of motor is positive. After encountering the negative limit switch, the motor will decelerate and run reversely, and the home detection position is the position where the position limit switch status changes.

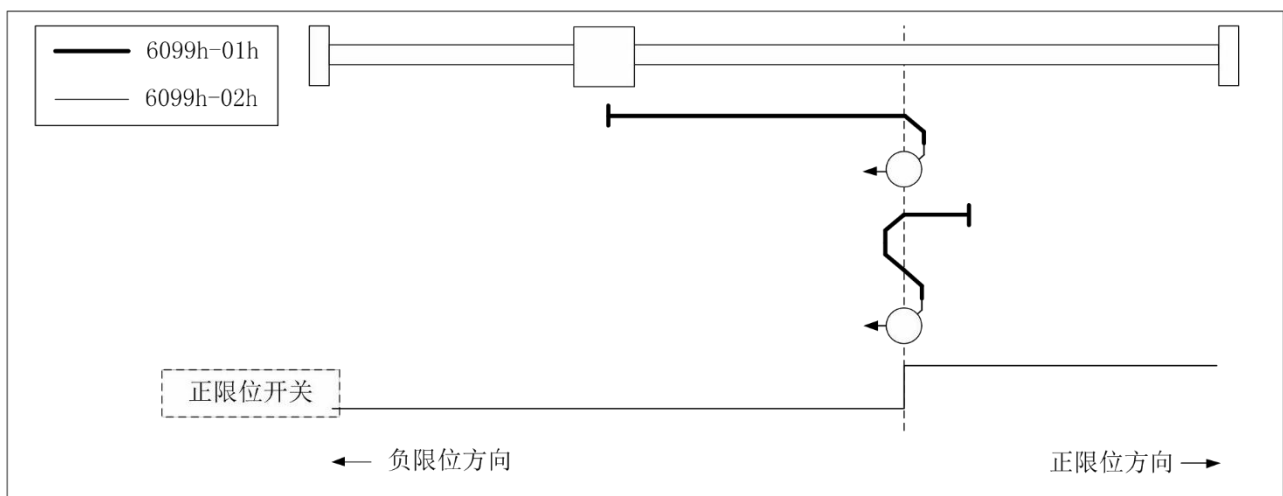

Method 18 diagram

## Methods 19 and 20

The direction of initialization operation is determined based on the status of the home position switch during startup. The home detection position is at the the negative direction side after the status change of the home position switch, or the negative direction side.

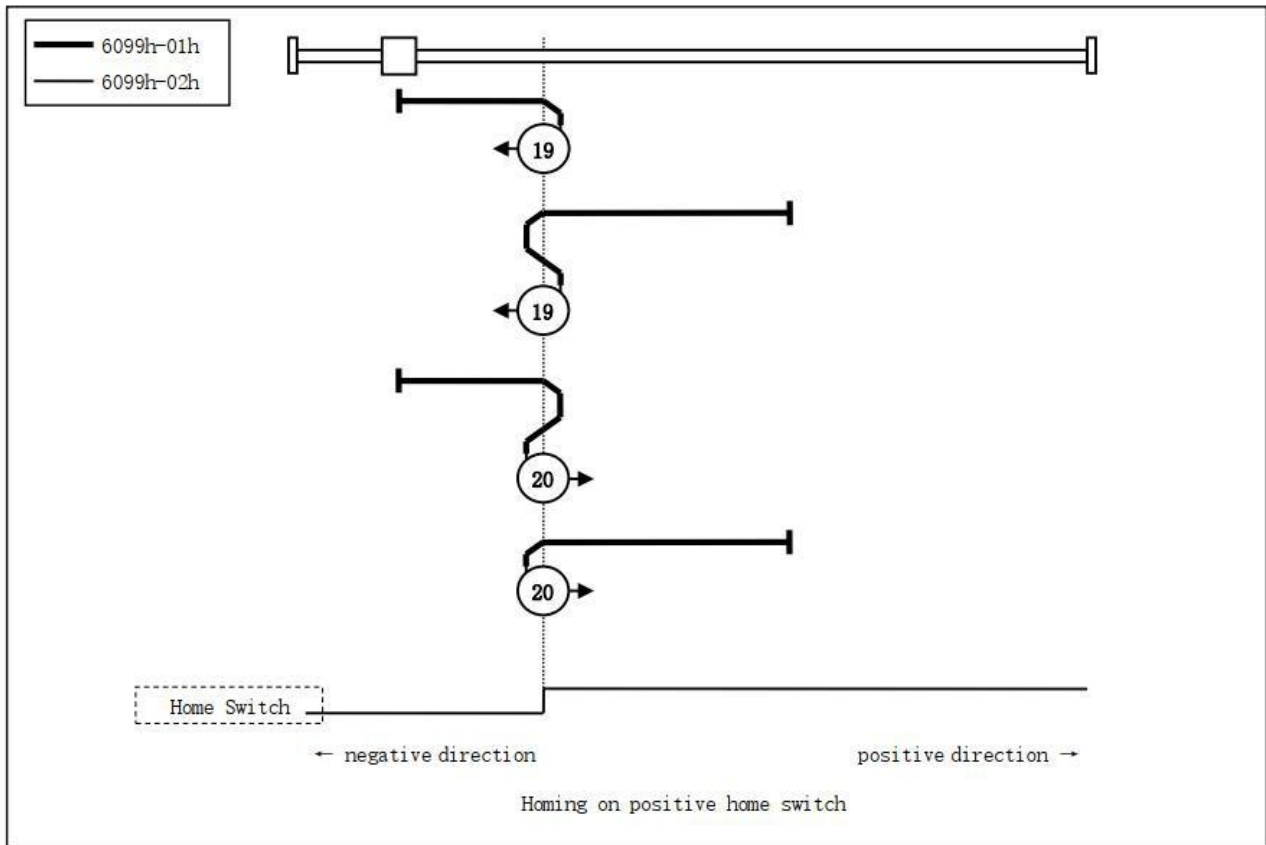

Diagrams of methods 19 and 20

## Methods 21 and 22

This method is similar to methods 19/20. The direction of initialization operation is determined based on the status of the home position switch during startup. The home detection position is at the positive direction side after the status change of the home position switch, or the negative direction side.

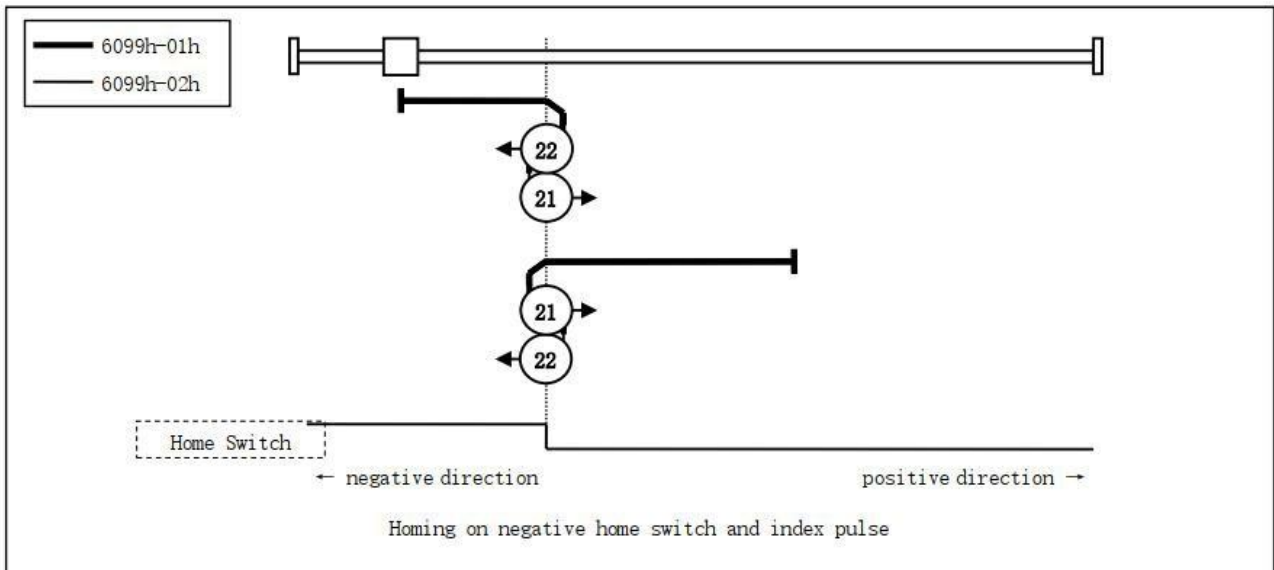

Diagrams of methods 21 and 22



## Methods 27, 28, 29 and 30:

In this method, the home position switch and negative signal are used.

The initialization action direction of methods 27 and 28 is the positive direction when the home position switch has already been activated at the beginning; the initialization action direction of methods 29 and 30 is the negative direction if the home position switch has already been activated at the beginning; the home detection position is the position where the status of the home position switch changes.

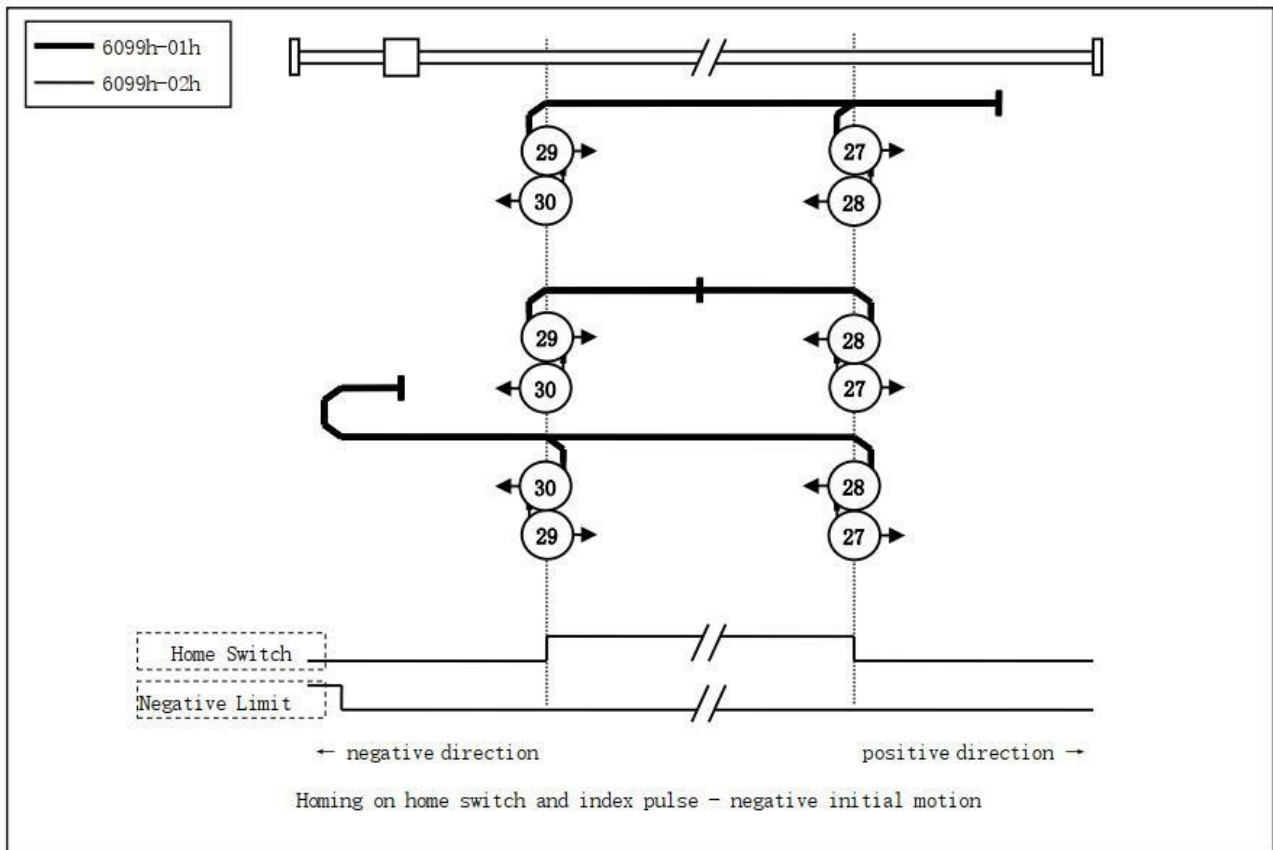

Diagrams of methods 27, 28, 29 and 30:

## Methods 33 and 34

In this method, only Z signal is used. The Z signal is detected as the home position after moving at the direction shown in the figure.

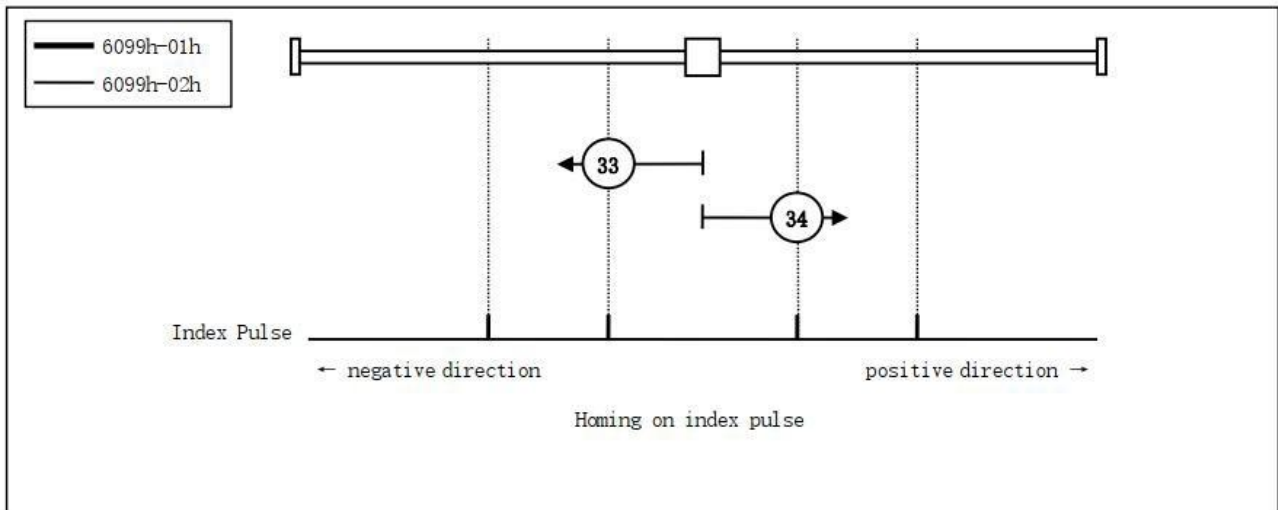

Diagrams of methods 33 and 34

## Methods 35, 37:

The current point is used as the home position

35 and 37 have the same functions, but based on the ETG specifications, it is recommended to use 37.

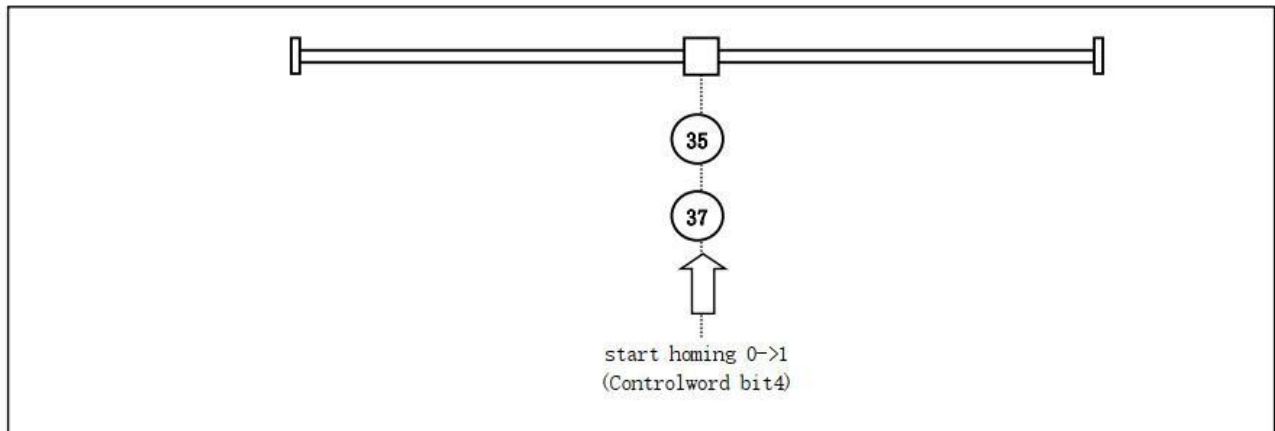

Diagrams of methods 35 and 37

## 7. Alarm

### 7.1 Error Code

The driver has two (red/green) LED lights to display status and error, and can also read the error register object 603F. When the motor is in the enabled state, the green indicator light will be always on. If the red LED light flashes, it indicates that an error has occurred. The error is displayed by combining the flashing red and green lights, and the specific meaning is as follows:

Status	Fault	Cause
Green light normally on	The driver operates normally	--
Green light flashing	The driver is not enabled	The driver does not receive the enabling signal
4 red lights and 1 green light	Drive power input overvoltage	The supply voltage is greater than 48VDC
5 red lights and 1 green light	Driver overcurrent	Motor wiring error or poor contact
6 red lights and 1 green light	Motor winding open circuit	The motor is not connected properly
3 red lights and 2 green lights	Internal voltage error	Too small power
4 red lights and 2 green lights	Drive power input undervoltage	The supply voltage is less than 24VDC

## 8. Contact Kaifull



### 凯福电机 KAIFULL

全国服务热线:

**400-960-1069**

投诉电话: 余先生 13790335790

公司传真: 0769-22493047

联系邮箱: yushuiliang@kaifull.net

公司总部: 广东省东莞市莞城区旗峰路162号中侨大厦7C1

湖北分公司: 武汉市东湖开发区光谷时代广场B幢1810室

江苏分公司: 苏州市吴中区郭巷东环南路999号A幢609-2号

深圳分公司: 深圳市龙岗坂田街道坂田国际中心H栋9楼916室



凯福官方微信



移动版官网