

# Y5SD2

## Five-phase Stepper Driver

### User Manual



Guangdong Kaifull Electronics Technology Co., Ltd.

## Contents

<b>1 FOREWORD</b> .....	<b>2</b>
<b>2 INSTALLATION DIMENSIONS</b> .....	<b>2</b>
<b>3 TECHNICAL SPECIFICATIONS</b> .....	<b>3</b>
<b>4 WIRING</b> .....	<b>4</b>
4.1 WIRING DIAGRAM .....	4
4.2 POWER CONNECTION .....	5
4.3 MOTOR CONNECTION .....	6
4.4 CONTROL SIGNAL CONNECTION .....	6
<b>5 PARAMETER SETTING</b> .....	<b>10</b>
5.1 OPERATING CURRENT SETTING .....	10
5.2 IDLE CURRENT SETTING .....	11
5.3 SUBDIVISION SETTING .....	12
<b>6 ALARM CODE</b> .....	<b>13</b>
<b>7 SOFTWARE SETTING</b> .....	<b>14</b>
7.1 DRIVER CONNECTION .....	14
7.2 DRIVER PARAMETERS MODIFICATION .....	17
7.3 PARAMETERS SAVING .....	19
7.4 SAVING/OPENING PARAMETER FILE .....	19
7.5 FIRMWARE UPDATE .....	20
<b>8 CONTACT KAIFULL</b> .....	<b>21</b>

# 1 Foreword

---

- Thank you for choosing Kaifull's product.
- This manual describes the use methods and safety precautions of the product.
- Please read this user manual carefully and use this product correctly and safely.
- After reading, please save it at a suitable place for easy access at any time.
- For technical support, please dial 400-960-1069 or +86-769-23033384.

# 2 Installation Dimensions

---

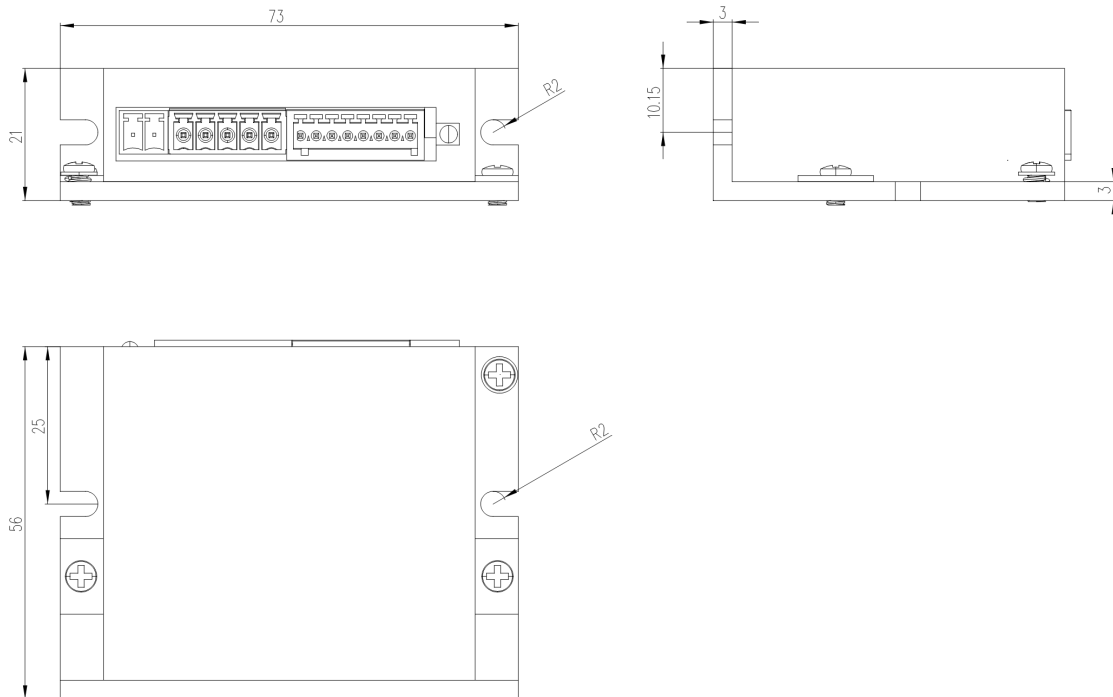

### 3 Technical Specifications

Technical Specifications		
Installation Dimensions	73 × 56 × 21 mm	
Input power	24 ~ 48V DC	
Current output	0.8 ~ 4.2A (peak current)	
Adaptive motor	Five-phase stepper motor	
Control mode	Pulse+direction, dual pulse, speed mode	
Communication interface	485 serial port	
Digital signal	Input signal	<u>Pulse, direction, enabling signal</u> : differential; optocoupler isolation; common end supports 5~24VDC; maximum frequency 250Khz
	Output signal	<u>Alarm output</u> : collector open circuit; opto-isolator; maximum output 100mA@30V;
Current tap position	Dial setting	0.8、1.3、1.8、2.2、2.7、3.2、3.7、4.2 A
	Software setting	0.1~4.2 A
Subdivided tap position	Dial setting	200、400、800、1600、3200、6400、12800、25600、1000、2000、4000、5000、6000、8000、10000、20000
	Software setting	Any even number between 200 and 51200
Recommended service environment	Temperature	0 ~ +55 °C
	Humidity	0~ 90%RH below
	Altitude	1000 m below
	environment	No corrosive gases or dust. The product shall not come in contact with water and oil.
Dielectric strength	AC1.5KV between ground wires, capable of withstanding voltage for 1 minute	
Protection grade	IP20	
Weight	0.1KG	

# 4 Wiring

## 4.1 Wiring diagram



## 4.2 Power Connection

The power supply specification of the driver is 24-48V DC. When you connect the power supply, connect the positive pole of the power supply to the V+ interface of the driver and the negative pole of the power supply to the V- interface.

- Applicable power supply wires: Wires of 0.5mm<sup>2</sup> and above

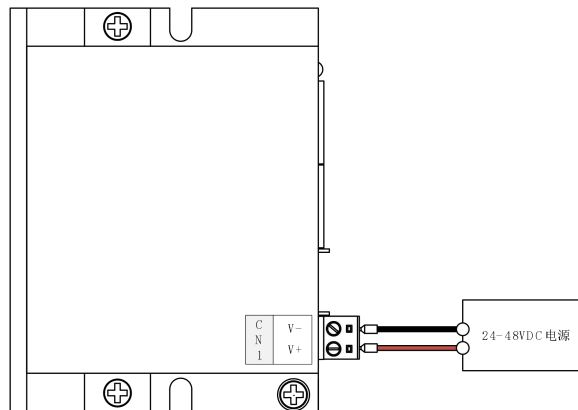

- Select the appropriate power supply

The following are recommendations for selecting the power supply when using different motors:

Motor flange (MM)	Supply voltage (DC)	Supply current
20/35	24V	≥1.0A
42	24V	≥2.0A
57/60	24-36V	≥4.0A



- Do not connect the positive and negative poles of the driver power supply reversely, as it may cause damage to the driver and will not be covered by warranty
- When the motor 57 and above is used and the motor is operating at a high speed, it will generate a large reverse electromotive force. At this time, use a higher-voltage power supply to improve the high-speed performance of the motor.

## 4.3 Motor Connection

When connecting the drive to the motor, connect the motor A, B, C, D, and E wires one by one to the drive CN2 interface according to the motor specifications. The power wires of the five-phase stepper motor are blue, red, orange, green, and black, corresponding to phases A, B, C, D and E.

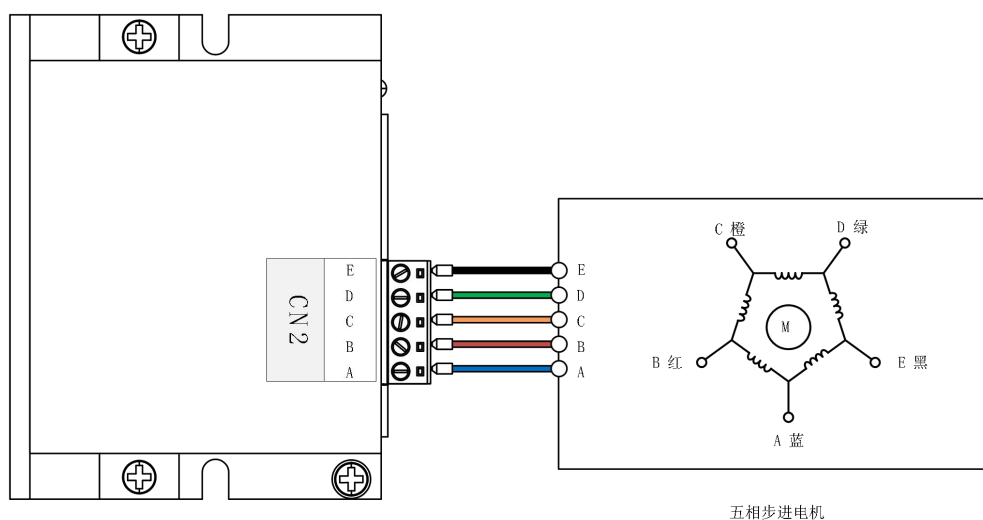

## 4.4 Control Signal Connection

Y5SD2 has 3 circuits of input and 1 circuit of alarm output signal.

- Applicable wires: Wires of 0.2mm<sup>2</sup> and above

Control signal	Input/output	Definition
PUL	Input	Pulse signal
DIR	Input	Direction signal
EN	Input	Enabling signal (when connected, the motor will be enabled to disconnect)
OUT	Output	Alarm output

## 4.4.1 Input Signal Connection

### ■ Pulse+direction mode

- NPN type connection method

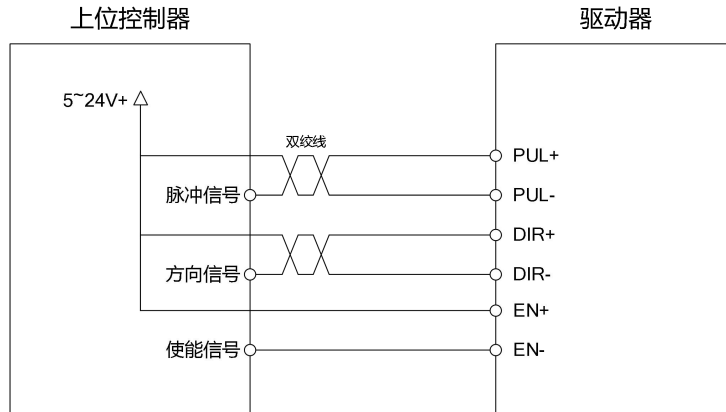

- PNP type connection method

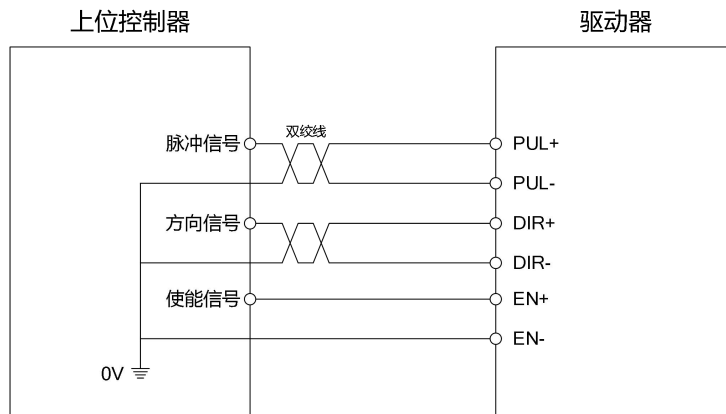

## ■ Dual pulse mode

- NPN type connection method

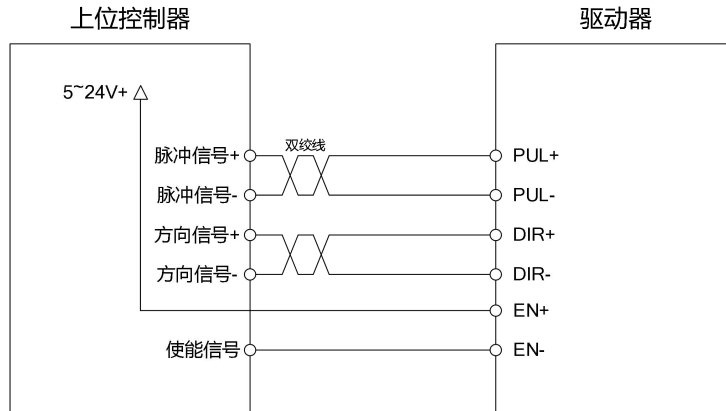

- PNP type connection method

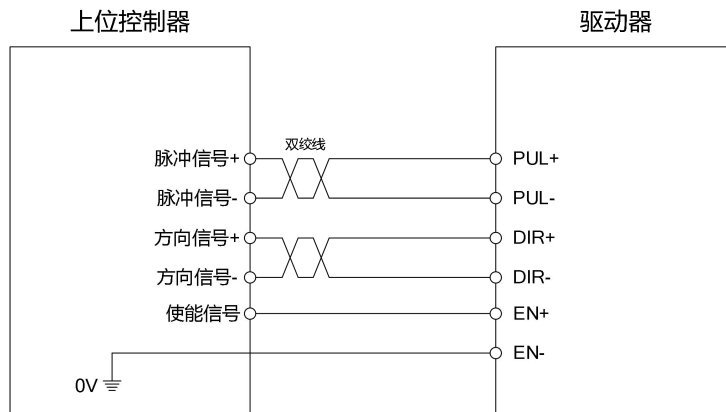

## 4.4.2 Alarm Output Connection

The alarm output interface of Y5SD2 is an open drain output, and can output different levels according to different wiring methods.

Status of the driver output port during operation:

ALM	When the drive is normal, it is OFF; when an alarm occurs, it is ON
-----	---

- NPN output

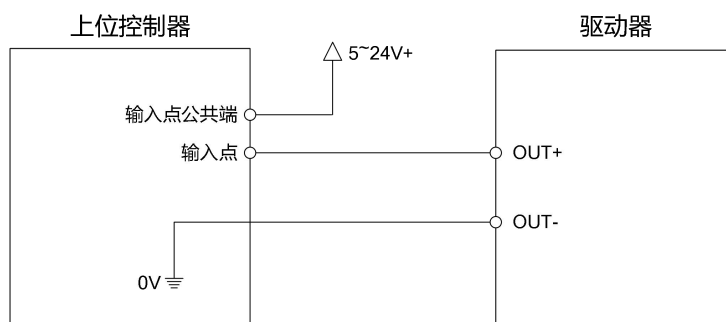

- PNP output

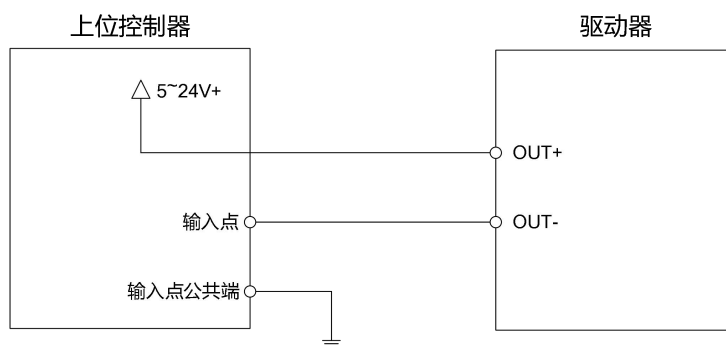





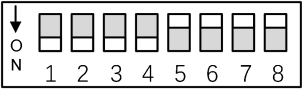

## 5 Parameter Setting

The dial switch SW1-SW8 on the top of the Y5SD2 driver is used to set the current and subdivision.

							
SW1	SW2	SW3	SW4	SW5	SW6	SW7	SW8
Operating current			Idle current	Subdivision setting			

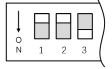
### 5.1 Operating Current Setting

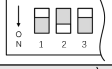
Y5SD2 sets the peak output current through the SW1, SW2, and SW3 dial switches, and users need to set it according to the rated current on the motor specification sheet. (The set current value should be set to be similar to the rated current of the motor.)

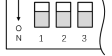
Operating current	SW1	SW2	SW3	Dial diagram
0.8 A (default)	ON	ON	ON	
1.3 A	OFF	ON	ON	
1.8 A	ON	OFF	ON	
2.2 A	OFF	OFF	ON	
2.7 A	ON	ON	OFF	
3.2 A	OFF	ON	OFF	
3.7 A	ON	OFF	OFF	
4.2 A	OFF	OFF	OFF	





- Generally, setting a larger current can increase the torque output of the motor, while also generating greater heat and noise.
- The set current should not exceed 1.5 times the rated current of the motor. Otherwise it may cause the motor to burn out.

## 5.2 Idle Current Setting

SW4 dialing is used to set the idle current to 50% or 90% of the operating current. When the motor enters standby mode, the output current of the driver will automatically decrease to the set value.











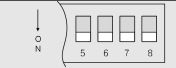
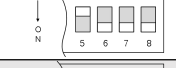

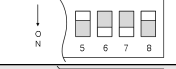

When the idle current is set to 90%, the motor can output a larger holding torque, and the heat generated by the motor will also increase. It is recommended to set the idle current to 50% in a safe situation to reduce motor heating.

Idle current	SW4	Dial diagram
50% (default)	ON	
90%	OFF	

### 5.3 Subdivision setting

SW5, SW6, SW7, and SW8 dials are used to set the number of pulses per revolution of the motor.

\*\*If the sub-divided tap positions in the table below cannot meet your application requirements, you can set SW5~SW8 to ON. At this time, you can set any even sub-divided tap position to be between 200~51200 through software

Subdivision (Pulse/revolution)	SW5	SW6	SW7	SW8	Dial diagram
200	ON	ON	ON	ON	
400	OFF	ON	ON	ON	
800	ON	OFF	ON	ON	
1600	OFF	OFF	ON	ON	
3200	ON	ON	OFF	ON	
6400	OFF	ON	OFF	ON	
12800	ON	OFF	OFF	ON	
25600	OFF	OFF	OFF	ON	
1000	ON	ON	ON	OFF	
2000	OFF	ON	ON	OFF	
4000	ON	OFF	ON	OFF	
5000	OFF	OFF	ON	OFF	
6000	ON	ON	OFF	OFF	
8000	OFF	ON	OFF	OFF	
10000	ON	OFF	OFF	OFF	
20000 (default)	OFF	OFF	OFF	OFF	

## 6 Alarm Code

---

The driver displays status and errors through a combination of flashing green and red LED indicator lights, with the specific meaning as follows:

LED indicator light	Meaning	Resolution
Green light normally on	Motor not enabled	-
Green light flashing	Motor enabled normally	-
4 red lights and 1 green light	Excessively high bus voltage	<ol style="list-style-type: none"> <li>1. Check whether the supply voltage of the driver is too high;</li> <li>2. In case of overvoltage during movement, the motor deceleration time can be increased.</li> </ol>
4 red LED lights and 2 green LED lights	Excessively low bus voltage	Check whether the supply voltage of the driver is too low;
5 red lights +1 green light	Two motors have overcurrent simultaneously	<ol style="list-style-type: none"> <li>1. Check whether the motor has been damaged;</li> <li>2. Check whether the set current of the driver is too high;</li> </ol>
6 red lights +1 green light	Two motors have open circuit simultaneously	<ol style="list-style-type: none"> <li>1. Check whether the motor wiring is correct;</li> <li>2. Check whether the motor has been damaged</li> </ol>
3 red lights +2 green lights	Internal voltage error	Check whether the power of the switching power supply is sufficient

# 7 Software Setting

The driver can be configured through the KF Step Drive Configuration software to set multiple internal parameters such as current, subdivision and control mode.

## 7.1 Driver Connection

### 7.1.1 Connecting Wire Preparation

- (1) USB to 485 connection wire
- (2) DB9 connector
- (3) 5PIN connection wire (model PH-5-2-150)

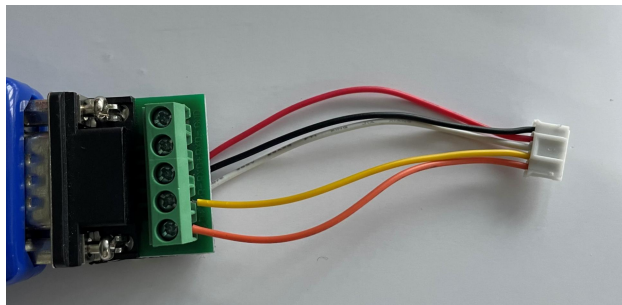
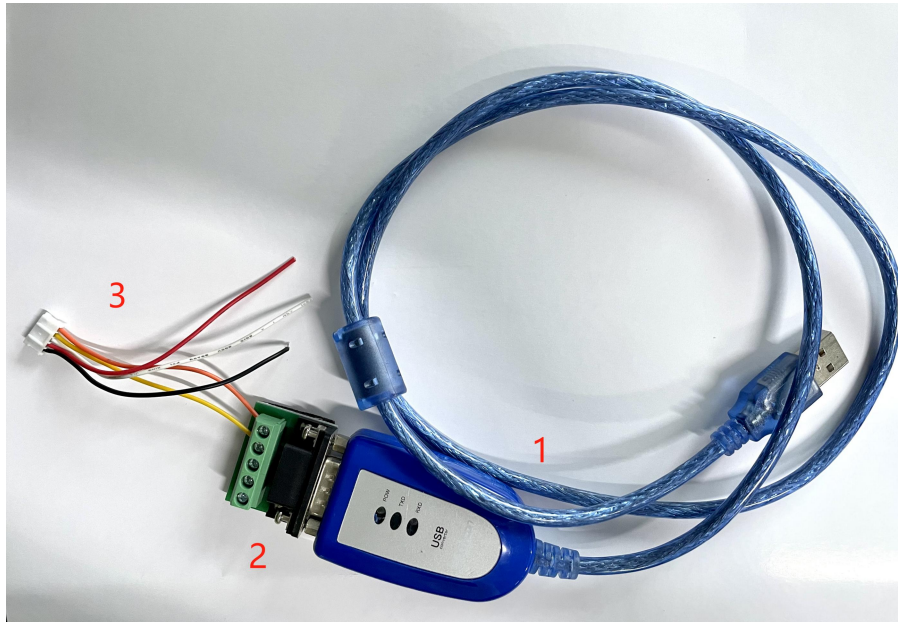

5pin connecting wire	DB9 connector
5 orange lights	485+
4 yellow lights	485-
3 white'	Not connected
2 red lights	Not connected
1 black lights	Not connected

## 7.1.2 Driver Connection

1. Insert the 5-pin wire into the driver communication port in the direction as shown in the following diagram



2. Start the Kaifull software

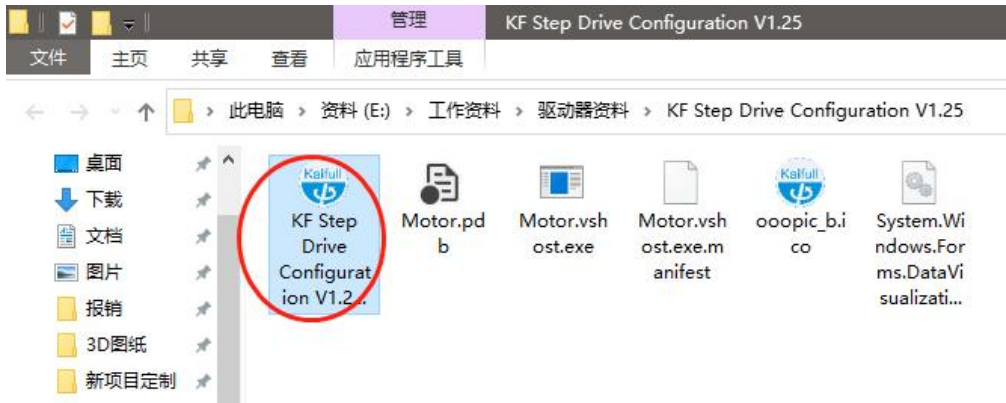

Software interface:



### 3. Select the correct COM port

Select the corresponding COM port connection on the Kaifu software by viewing the computer device administrator



### 4. Select the driver & upload the parameters

Click "Connect"



You may upload the parameters after successful connection



## 7.2 Driver Parameters Modification

### 7.2.1 Control Mode

Y5SD2 is compatible with multiple control modes. Please choose the appropriate mode according to your specific application requirements.



## 7.2.2 Current Setting

Current setting method:

Default parameters setting of motor	<input type="checkbox"/> Enabling: The current is set by dialing; <input checked="" type="checkbox"/> disabling: current is set by software
Continuous current	The idle current of the motor is recommended to be set to 50% of the rated current of the motor
Peak current	The peak current for normal operation of the motor is recommended to be set to the rated current of the motor
Startup scanning current	It is the current used for phase finding when the motor is enabled. It is recommended to set it to the rated current of the motor

Example: Setting the current parameters of a motor with a rated current of 0.5A through software

Step1: 参数配置 Step2: 电机控制整定 配置EtherCAT 电机状态 固件升级

1. 电机配置

电机型号: 57系列 电机ID: 7

细分旋钮: 0 地址旋钮: 6

默认方向:  正向  反向 正向

脉冲模式:  单脉冲  双脉冲

电机默认参数设置 不使能

2. 控制模式设置

连续电流 0.18 (0.01-5A)

**峰值电流 0.5 (0.01-8A)**

开机扫描电流 0.53 (0.01-8.5A)

## 7.2.3 Subdivision Setting

When the subdivision tap positions provided by the combination of dials in the drive do not meet the actual application requirements, the subdivision can be set through software. At this time, all dials SW5-SW8 need to be set to ON. Otherwise, the subdivision will be set by the dials.

SW5	SW6	SW7	SW8	Dial diagram
ON	ON	ON	ON	

Subdivided electronic gear ratio: You can input any even value between 200 and 51200, in pulse/revolution.

2. 控制设置

编码器电子齿轮比 4000 (200-51200)

**细分电子齿轮比 3600 (200-51200)**

平滑滤波 100 (1-1500)

## 7.3 Parameters Saving

After setting all parameters, click "One button download" to power off and save all parameters



Successful save prompt:

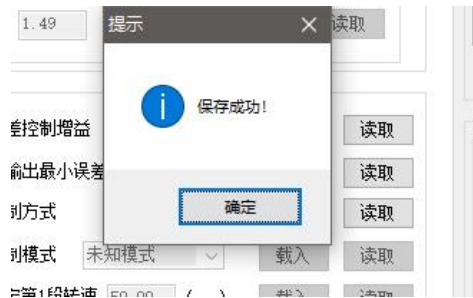

## 7.4 Saving/Opening Parameter File

Users can save the current parameters as a file for easy downloading to other drivers



## 7.5 Firmware Update

Select the files to be upgraded and click "Start"

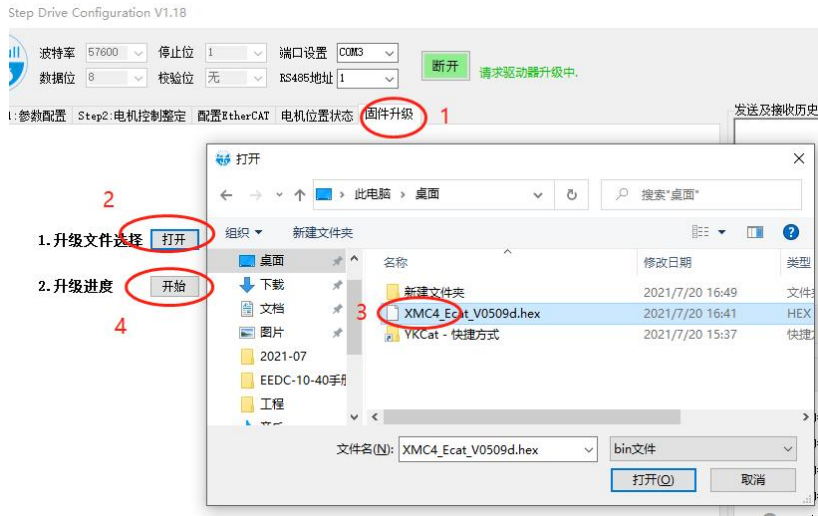

Waiting until the progress bar reaches 100%, which indicates that the update has been completed



## 8 Contact Kaifull



更多更新的凯福咨询，请扫码关注



微信公众号

官网

### 广东凯福电子科技有限公司

GUANGDONG KAIFULL ELECTRONICS TECHNOLOGY CO., LTD.

■ 苏州分公司 ■ 宁波分公司 ■ 武汉分公司 ■ 上海分公司

电话：0769-23033384

传真：0769-22493047

网站：www.kaifull.net

详细地址：广东省东莞市高埗镇高龙东路5号 凯福科技园

版权所有，翻版必究