

磨砂面
Frosted surface

A-A

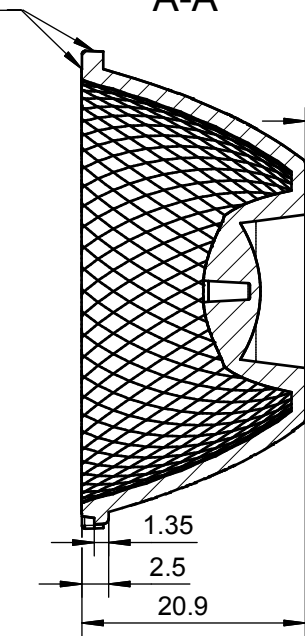

LED基板上表面
on the surface of
LED substrate

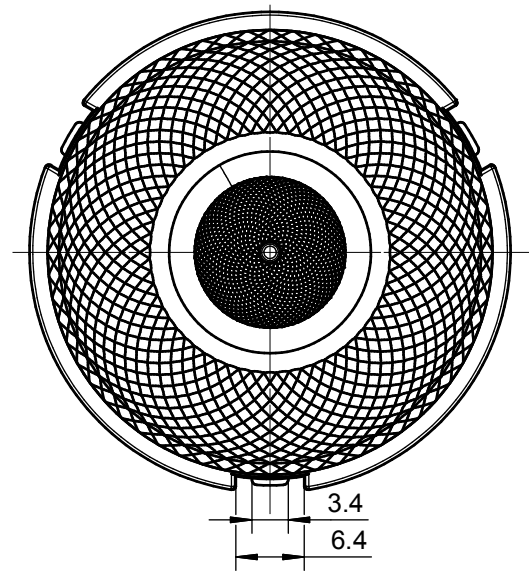

B-B

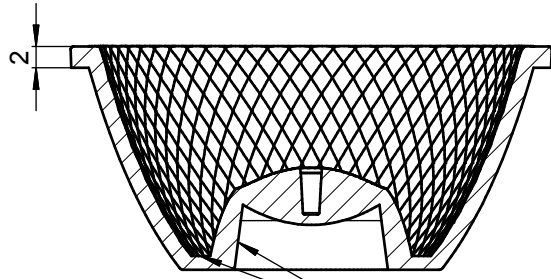

磨砂面
Frosted surface

技术要求:
1、未注圆角及拔模斜度按3D图。
2、未注尺寸公差按右表。
3、表面无飞边, 缩水, 气泡等缺陷。
*4、灯具采用胶圈防水时: 要求散热器与胶圈的接触面的粗糙度: Ra<3.2μm

Technical remark:
1. Fillet and inclination not indicated according to 3D drawing.
2. Dimensional tolerances not indicated are shown in the right list.
3. The surface has no flash, shrinkage, bubbles and other defects.
*4. When the lamp adopts rubber ring for waterproofing: the roughness of the contact surface between the radiator and the rubber ring is required: Ra<3.2μm

基本尺寸	公差值
Basic size	Tolerance value
<3	±0.1
3~10	±0.15
10~24	±0.20
24~65	±0.35
65~140	±0.50
140~250	±0.80
250~450	±1.2
>450	±2.0

序号	更改标记	更改内容	更改日期	签名	序号	更改标记	更改内容	更改日期	签名
Item	Change mark	Change content	Change date	Signature	Item	Change mark	Change content	Change date	Signature
2					4				
1					3				
光学设计 Optical design					Title:				
结构设计 Structural design					HK 双子45@21-24度反光杯 HK Gemini 45@21-24° Reflective Cup				
审核 Verify					Drawing No. HK-SZ-45@21-24-D6-2#-1g-1				
审定 Approval					Part No. 1.08.92115				
材料 Material:				PC半电镀 PC semi-plating		CDHK			