

LED基板上表面
on the surface of
LED substrate

指定面为磨砂面
Specify the surface
as a frosted surface

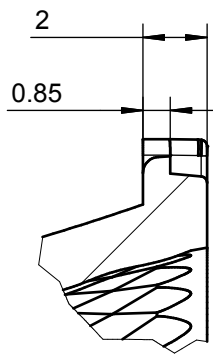

B-B

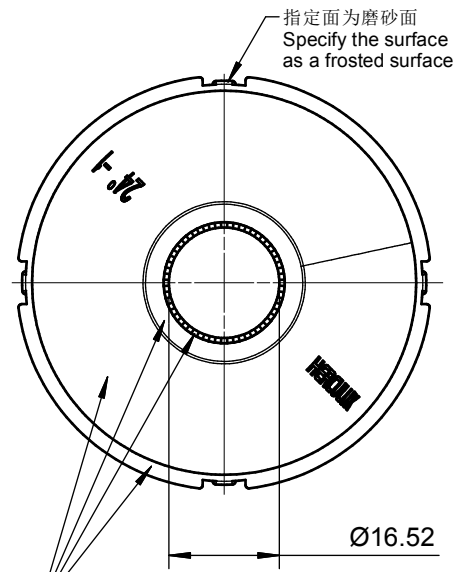
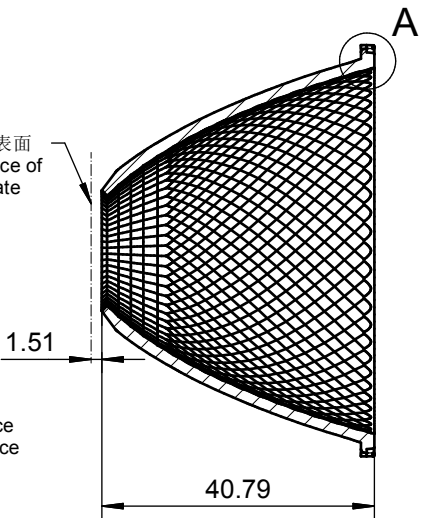

指定面为磨砂面
Specify the surface
as a frosted surface

指定面为磨砂面
Specify the surface
as a frosted surface

技术要求:
1、未注圆角及拔模斜度按3D图。
2、未注尺寸公差按右表。
3、表面无飞边, 缩水, 气泡等缺陷。
*4、灯具采用胶圈防水时: 要求散热器与胶圈的接触面的粗糙度: Ra<3.2µm

Technical remark:
1. Fillet and inclination not indicated according to 3D drawing.
2. Dimensional tolerances not indicated are shown in the right list.
3. The surface has no flash, shrinkage, bubbles and other defects.
*4. When the lamp adopts rubber ring for waterproofing: the roughness of the contact surface between the radiator and the rubber ring is required: Ra<3.2µm

基本尺寸	公差值
Basic size	Tolerance value
<3	±0.1
3~10	±0.15
10~24	±0.20
24~65	±0.35
65~140	±0.50
140~250	±0.80
250~450	±1.2
>450	±2.0

序号	更改标记	更改内容	更改日期	签名	序号	更改标记	更改内容	更改日期	签名
Item	Change mark	Change content	Change date	Signature	Item	Change mark	Change content	Change date	Signature
2					4				
1					3				
光学设计 Optical design					Title: HK 光影62@41-24度反光杯 HK V series 62@41-24 deg reflector				
结构设计 Structural design					Drawing No. HK-GY-62@41-24-D14.5-2#-1g-1				
审核 Verify					Part No. 1.08.23170				
审定 Approval					材料 Material: PC 镀铝 PC aluminium plating				
					CDHK				