

A-A  
2:1

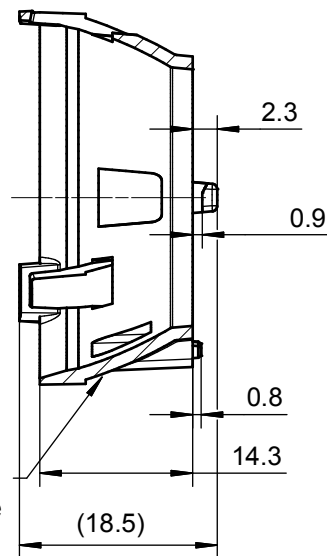

磨砂面  
Frosted surface

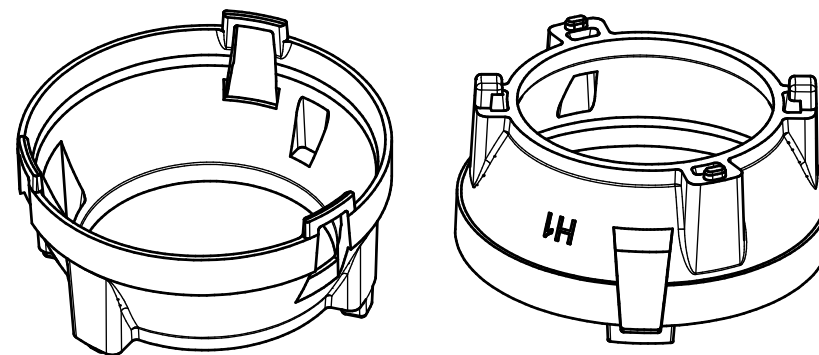
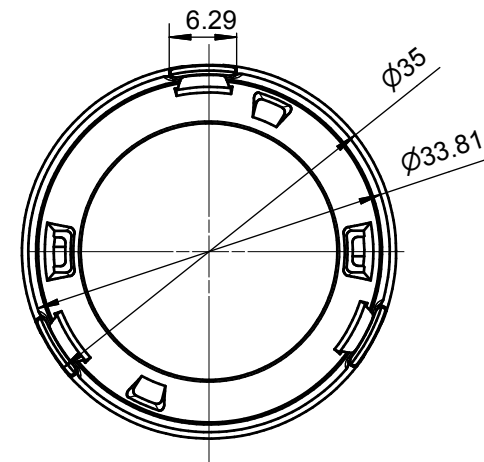

- 技术要求:  
 1、未注圆角及拔模斜度按3D图。  
 2、未注尺寸公差按右表。  
 3、表面无飞边, 缩水, 气泡等缺陷。  
 \*4、灯具采用胶圈防水时: 要求散热器与胶圈的接触面的粗糙度: Ra<3.2µm

- Technical remark:  
 1.Fillet and inclination not indicated according to 3D drawing.  
 2. Dimensional tolerances not indicated are shown in the right list.  
 3. The surface has no flash, shrinkage, bubbles and other defects.  
 \*4. When the lamp adopts rubber ring for waterproofing: the roughness of the contact surface between the radiator and the rubber ring is required: Ra<3.2µm

基本尺寸	公差值
Basic size	Tolerance value
<3	±0.1
3~10	±0.15
10~24	±0.20
24~65	±0.35
65~140	±0.50
140~250	±0.80
250~450	±1.2
>450	±2.0

序号	更改标记	更改内容	更改日期	签名	序号	更改标记	更改内容	更改日期	签名
Item	Change mark	Change content	Change date	Signature	Item	Change mark	Change content	Change date	Signature
2					4				
1					3				
Title:				Drawing No.		HK 黑光35@16透镜支架3(D35)			
HK Dark 35@16 lens holder 3(D35)				Part No.		1.07.12836H			
材料 Material: PC 黑色(PC Black)				CDHK					