

LVMA

Automatic Transfer Switch Instruction

<When installing and using, pay attention to personal safety, and please read the manual carefully>



I.General

Automatic transfer switch is a high-tech product developed by our company, Comply with GB/T14048.11Standards, also in line with 《 Fire Protection Code for High-Rise Civil Buildings》 , 《 Emergency Lighting Design Guidelines》 etc.The parts and components of the product have undergone strict aging and screening. The finished product has been energized and aged at a continuous high temperature for 24 hours, and finally passed the loading inspection before leaving the factory. Thus ensuring the reliability and safety of the product .

Suitable for AC 400V and below, rated frequency 50Hz. In the power supply, there is phase loss, overvoltage, Under the control of the controller, the transfer switch can quickly change the load from the common power supply to the backup power supply (the backup power supply must be normal at this time) in the case of fault conditions such as undervoltage. The user can also put the load in an intermediate position when needed, so that the load is neither connected to the normal power supply nor to the standby power supply.

This product is mainly used for the primary and secondary loads specified by the state, and is widely used in fire-fighting, post and telecommunications Information, hospitals, hotels, urban rail transit, high-rise buildings, industrial assembly lines, television stations, etc. Places with continuous power supply. Commonly power sources can be power grids, self-starting generator sets, battery packs, etc.

Remark :

Two-stage automatic transfer switch, when the switch receives the transfer signal, it will switch from one power supply to another without stopping in the middle off position.

Three-stage automatic transfer switch. After the switch receives the transfer signal, it can be switched from one power supply to another power supply immediately (or after a preset delay time), Also It can be switched from a power supply to an intermediate disconnected position that is not connected to any power supply.

- The switch level : PC Class.
- The wiring method is the front wiring method of the board.
- AC110V is Special customized products .

II.Working Conditions

- Ambient air temperature: ambient temperature -5°C to $+40^{\circ}\text{C}$, and the 24-hour average temperature value does not exceed Over $+35^{\circ}\text{C}$. Users whose ambient air temperature is higher than $+40^{\circ}\text{C}$ or lower than -5°C should consult with the manufacturer.
- The highest temperature of atmospheric humidity: when the degree is $+40^{\circ}\text{C}$, the relative humidity does not exceed 50%, and the maximum relative humidity per month Degree 90%, resistant to the influence of humid air on the sea, and can allow higher relative humidity at lower temperatures , special measures should be taken for the occasional condensation caused by temperature changes.
- Installation altitude: The altitude of the installation site does not exceed 2000 meters. When used at higher altitudes, the dielectric strength and cooling effect of the air should be considered to be reduced, please consult with the manufacturer.
- Pollution level: The environmental pollution level of the installation site is level 3 .
- Installation category: IV .
- Installation inclination: the product is fixedly installed in the cabinet, the maximum inclination is $\pm 22.5^{\circ}$.
- Arcing distance: The arcing distance is 30mm when AC 400V. The arcing distance when AC 690V is 60mm.

III. Model And Meaning

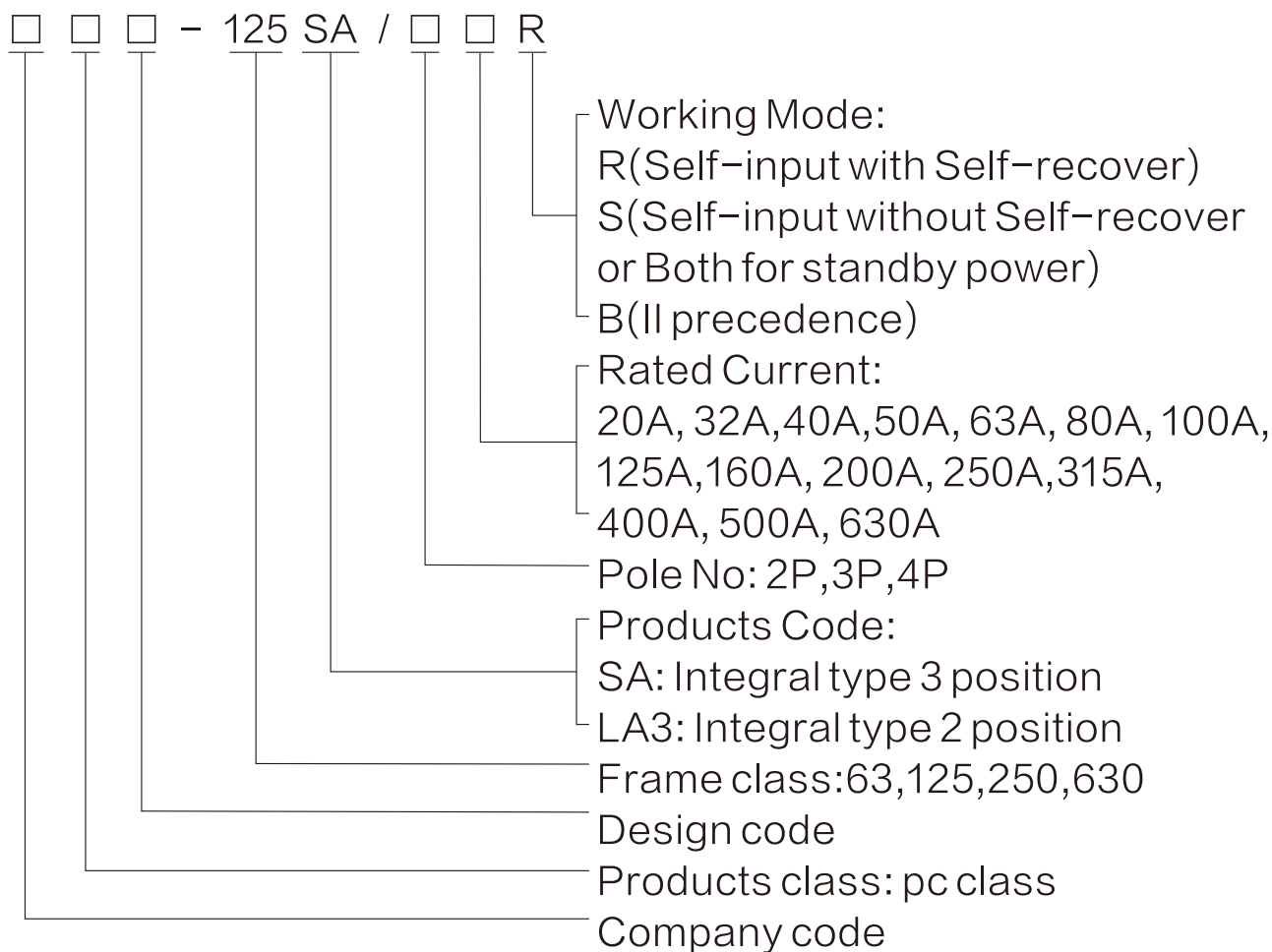

Remark : The default of SA ,LA3 comes with power grid-generator start and stop port, communication is optional .

IV. Technology Parameter

Mode :		SA Type, LA3 Type									
Insulation voltage		AC690V									
Rated voltage		400V									
Rated current		20A ~ 125A			160A ~ 250A			315A ~ 630A			
Rated impulse withstand voltage		8kV									
Kind of throw		Double throw									
Wiring method		Front board									
Number of pole		2P	3P	4P	2P	3P	4P	2P	3P	4P	
Weight		6	6.3	7	6	8	10	11	13.6	16.2	
Rated control power current	AC100V/110V	3	3	4	3	4	5	5	5	7	
	AC200V/220V	1.5	1.5	2	1.5	2	2.5	2.5	2.5	3	
Performance	Short-time resistance current		10kA								
	Through to breaking capacity		17kA								
	Transfer time	A Power	Input	80ms			80ms			100ms	
			Break	30ms			30ms			30ms	
		B Power	Input	100ms			100ms			120ms	
			Break	30ms			30ms			30ms	
	Electrical Life/ Mechanical Life		1000/5000						1000/4000		
	Operating cycle		60times/hour								
Use type		AC-33iB									
Auxiliary switch (Optional)		A、 B power source side are both 2 normal open, 2 normal closed, switch capability 15A/AC250V									
Accessories		Manual handle									

Notice :

The weight, Short time current, operate current and trip current are all for reference.

V. Wiring Diagram

- SA Type Wiring Diagram

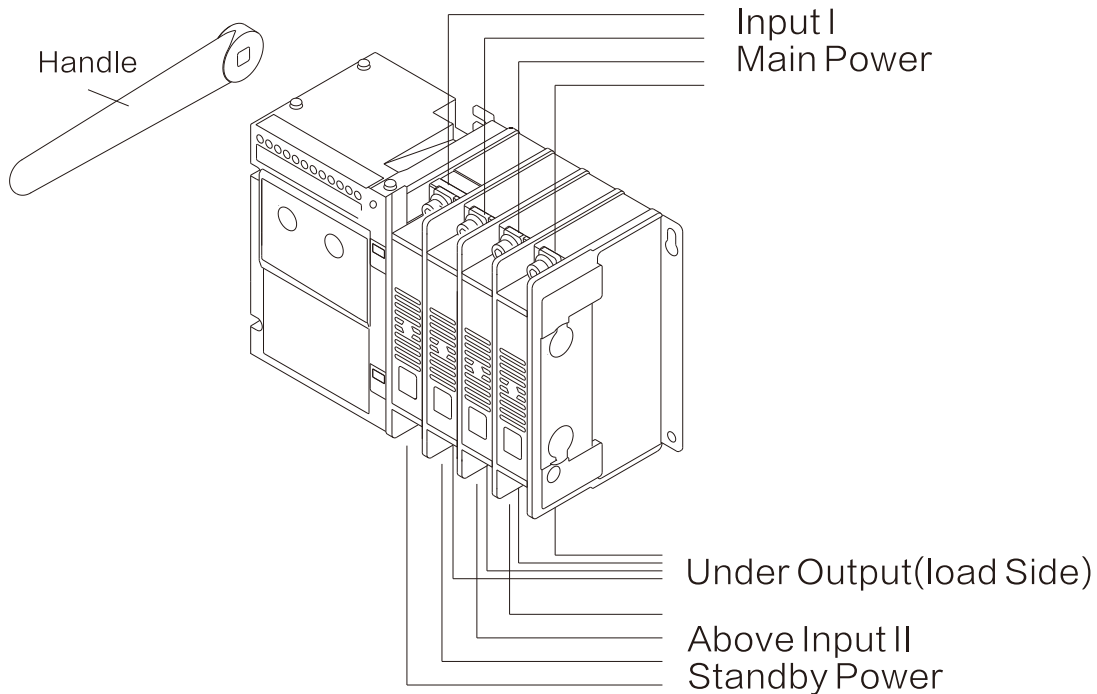

VI. SA Type Switch Wiring Terminal Indication

- SA type terminal block

1	2	3/	4	5/	6	7	8	9	10	11	12
normal earth wire (3P)	standby earth wire (3P)	standby power closing	Output without power	normal power closing	output without power	output without power	Fire-fighting feedback	output without power	fire-fighting	output without power	Start the generator

- Start generator: when fault occurs in the normal power, this port will connect after delaying some time.
- Fire-fighting: Connect the fire-fighting port, double disconnecting-light is on, the ATS double disconnect. Remove the connection, push the automatic/manual pushbutton to reset.
- Fire-fighting feedback: When ATS is in double-disconnecting state, the fire-fighting port connects.
- Normal close: When the normal power of ATS is in closing state,

closing signal without power is output from this port.

- Standby close: When the standby power of ATS is in closing state, closing signal without power is output from this port.
- Normal earth wire: When ATS are 3 phases, the normal earth wire is connected into this port.

Remark: The normal earth wire and standby earth wire is just suitable for ATS of 3 phases.

■ LA3 type terminal block instruction

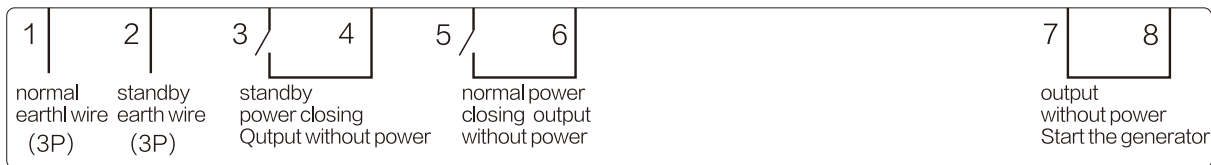

- Start generator: when fault occurs in the normal power, this port will connect after delaying some time.
- Normal close: When the normal power of ATS is in closing state, closing signal without power is output from this port.
- Standby close: When the standby power of ATS is in closing state, closing signal without power is output from this port.
- Normal earth wire: When ATS are 3 phases, the normal earth wire is connected into this port.
- Standby earth wire: When ATS are 3 phases, the standby earth wire is

Remark: The normal earth wire and standby earth wire is just suitable for ATS of 3 phases.

■ Communication port description

- 485A and 485B: RS485 communication terminal
- Communication protocol parameters, module address: 1 (range: 1–32, user can set)
- Baud rate : 9600bps
- Data bits: 8 bits
- Parity bit: none

Note: NC is reserved for undefined ports, users are not allowed to connect.

VII. Work mode setting instructions

- Enter mode settings.

In the automatic state, press and hold "I Common" and "II Standby" at the same time for ten seconds to enter the mode setting. At this time, the "A" and "B" lights of the I power supply are on or the "Manual" and "Auto" lights are on.

"A" light on means automatic switch and automatic recovery, "manual" light on means automatic switch and no automatic recovery. "B" light on means I Common priority, "Auto" light on means II standby priority.

- Mode conversion.

Click the "I Common" button to change between the modes of automatic switching with automatic recovery and automatic switching without automatic recovery. Click the "II Backup" button to switch between I common priority and II backup priority mode.

- Exit mode.

Click the "O power off" button to exit and save the mode.

VIII. Shape and installation dimensions

Switch panel safety distance size: 30mm(400V),60mm(690V)

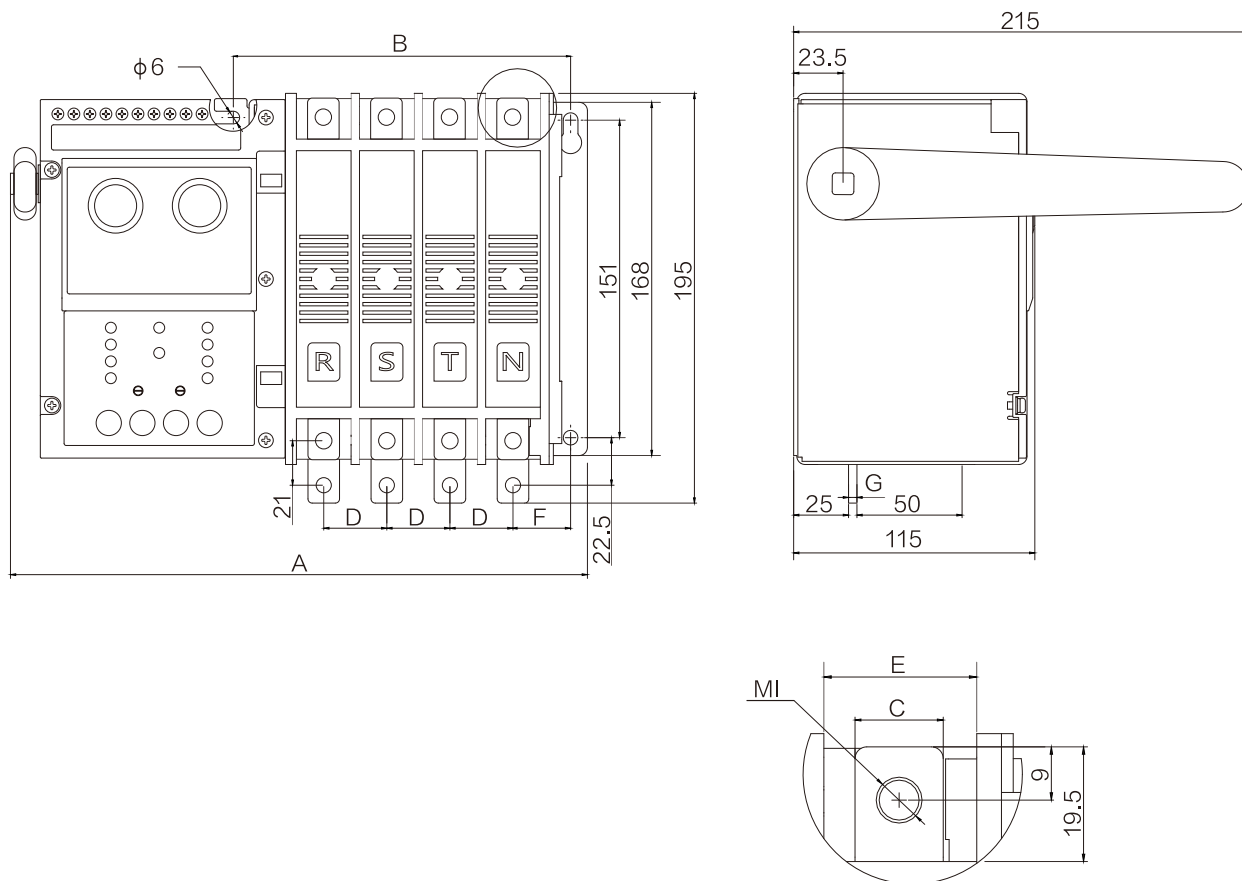

Model	Size	A	B	C	D	E	F	G	I
	Pole								
63SA 63LA3	2P	205	91	12	20	15	33.5	2	M5
	3P	225	111						
	4P	245	131						
125SA 125LA3	2P	223	100	15	30	26	27.5	4	M8
	3P	253	130						
	4P	283	160						
250SA 250LA3	2P	231	111	20	35	31	30	4	
	3P	266	146						
	4P	301	181						

Switch panel safety distance size: 30mm(400V), 60mm(690V)

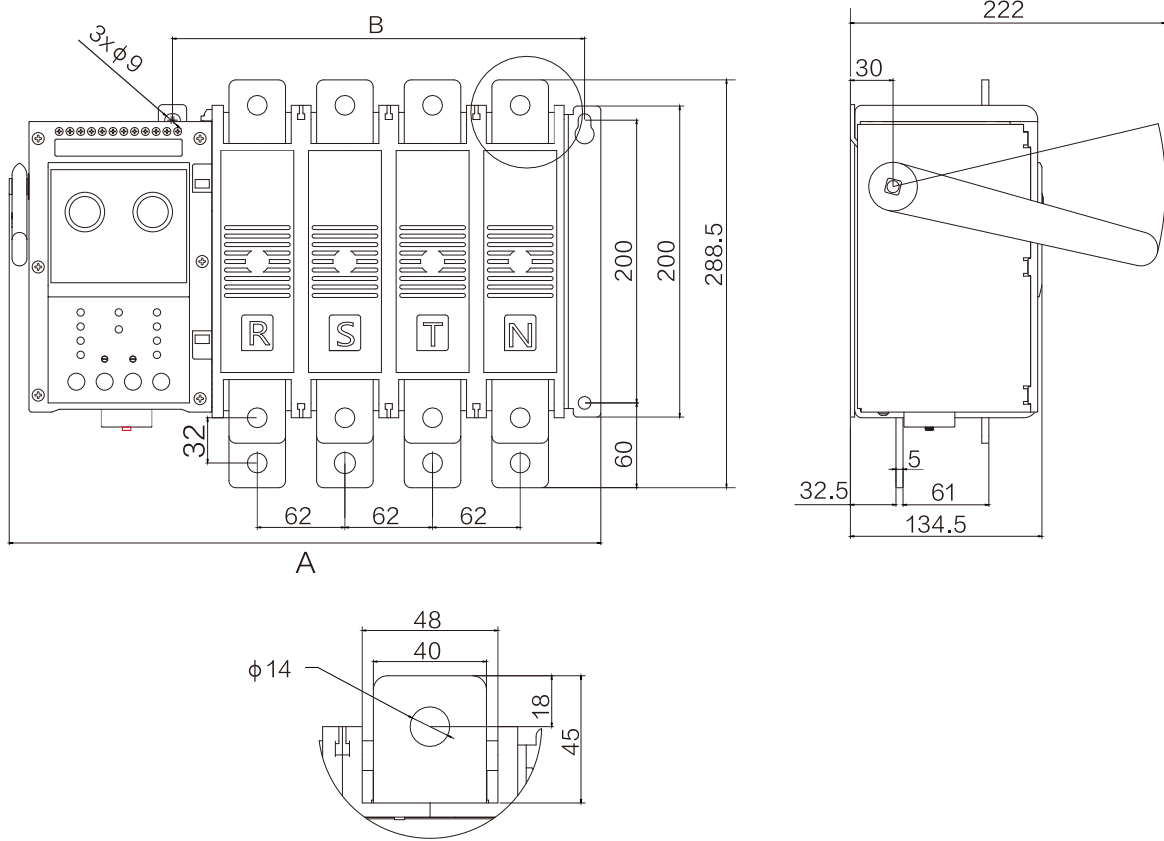

Model	Pole / Size	A	B
630SA 630LA3	2P	295	168
	3P	357	230
	4P	419	292

IX. Manual operation method and Notes.

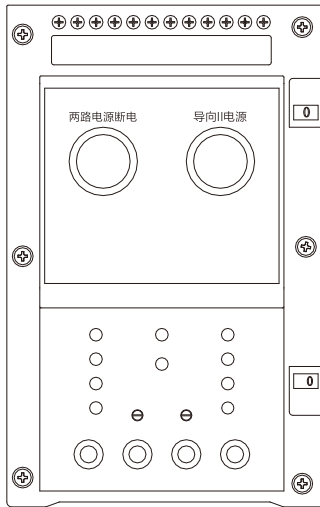

SA model 3 position

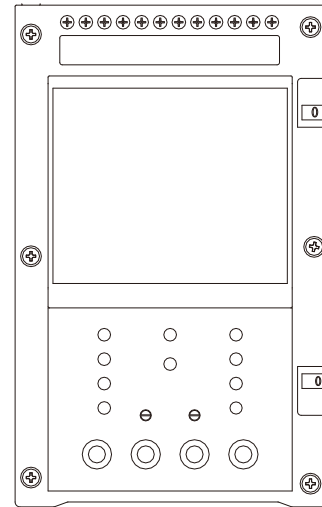

LA3 model 2 position

- I Common ON method: press the "two-way power off" button (as shown in the figure), so that both the common and standby power supplies are in the OFF position (LA3 two-stage type does not need this operation, SA-type three-stage same as this button operation), Use the handle to turn the manual shaft in the direction indicated by the arrow, so that the I Common in the ON position.
- II Standby ON method: press the "two-way power off" button (as shown in the figure), so that both the common and standby power supplies are in the OFF position (LA3 two-stage type does not need this operation, SA-type three-stage same as this button operation), Then press the "Guide II Standby" button and keep it, and at the same time turn the manual shaft in the direction indicated by the arrow to put the II Standby in the ON position.
- Manual trip method: (only applicable to SA type three-stage type, LA3 type two-stage type can only be converted but not tripped) In order to ensure safety, please press the "two-way power off" button to jump Take off. (Please confirm whether the switch is tripped by the ON/OFF indicator).

Note: Manual operation is prohibited when the switch is loaded. The controller must be in manual or power-off state during manual operation.

X.Maintenance and storage

Inspection and maintenance must be carried out by professionals. All external power supplies should be cut off during inspection and maintenance. In order to maintain the performance of the power switch and keep it in good condition, the first maintenance inspection shall be carried out within one year after installation, and regular maintenance shall be done at least once a year thereafter.

ZHEJIANG LVMA IMPORT AND EXPORT CO., LTD.

Mobile: 18157733126

E-mail: info@lvma-ele.com

Http: www.lvma-ele.com

ADD: No. 6688, Xuyang Road, Chengdong Street,

Yueqing City, Wenzhou City, Zhejiang Province

(9th Floor, Building 5, Headquarters Economic Park)

It is recommended to send the manual to the end user