

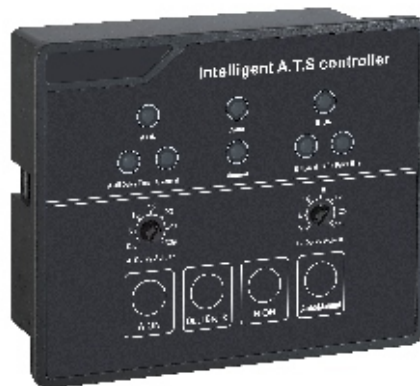

Read the operation instruction carefully before installation

# **ATS CONTROLLER Y-701/702 SERIES OPERATION INSTRUCTION**



# 1.INTRODUCTION

Y-701/Y-702 series Dual-Automatic Transfer Switch Controller is an ideal ATS controller which equipped with Microprocessor Measuring unit, Programmable Output unit, Communication unit(only 702),Indicator Display(701 NORMAL,702 LED) function, adjustable Conversion Delay function, adjustable working models and Intelligent Power Module to reduce the risk of man-made operation.

Due to the core is made up of microprocessor, Y-701/Y-702 series controller can detects any tiny changes(over-voltage,under-voltage and lacking phase) of the circuit and output the passive switch quantity signal.

# 2.OPERATIONAL ENVIRONMENT

- The ambient temperature should be higher than -10°C and lower than 60°C.
- the ambient altitude should not be higher than 2000m.
- the ambient electrical pollution class should not be higher than level 3.
- the ambient relative air humidity should not be higher than 50%,40°C,the ambient temperature should not be higher than 25°C while in the wettest month(The average maximum humidity of the month should be lower than 90%).
- If the environment is not up to the standard,the demand-side should notice the supply-side in advance.

# 3.PRODUCT FEATURES

Products model number	Y-701	Y-702
Installation method	Fission type	
Display mode	Indicator light	LED
Rated duty	Uninterrupted duty	
Self- input and self restore	■	■

Normal port and standby port share to each other	■	■
Generator auto-start function	■	■
Normal power detect	■	■
Standby power detect	four- phase lacking phase detection, three-phase over-voltage/under-voltage detection.	
Passive fire protection input	four- phase lacking phase detection, three-phase over-voltage/under-voltage detection.	
(dc9-36v)active fire protection input	■	■
Active fire control input	■	■
Voltage real-time display	■	■
Normal power and standby power indication	□	■
Normal power and standby power	■	■
Over-voltage/under-voltage adjustable	■	■
Generator rev. Stop time adjustable	■	■(F/F1)
Programmable output	□	■
Rs485 communicating function	□	■

Note: only the solid squares have the function

## 4.FUNCTION INTRODUCTION

- Self-input and self-restore.when the normal power was broke down(lacking phase, over- voltage or under-voltage),The ATS will connect up to the standby power until the grid back to normal.
- Self-input but no self-restore.not same to the 1,the switch will keep connecting up to the standby power until manual operation.
- Power port share to each other. Followed 2,now the power grid is right, and the switch is connecting up to standby power, till the standby power break down, the switch will turn back to the power grid.
- Error alarm. when the ordered instruction can't be execute in the prescribed time, the controller will stop executing(outputting),and the Y-701's indicator light will start system checking(at same time the Y-702's indicator light shows dual flicker).press the"Manual/Auto" button to stop the alarm.

## 5.SETTING MODE OF Y-701 CONTROLLER

- setting mode of self-input and self-restore, self-input but no self-restore, power port share to each other.

In the "Auto" mode, press both "A closing" and "B closing" buttons to start setting, then press "A switch on" to select the right mode.

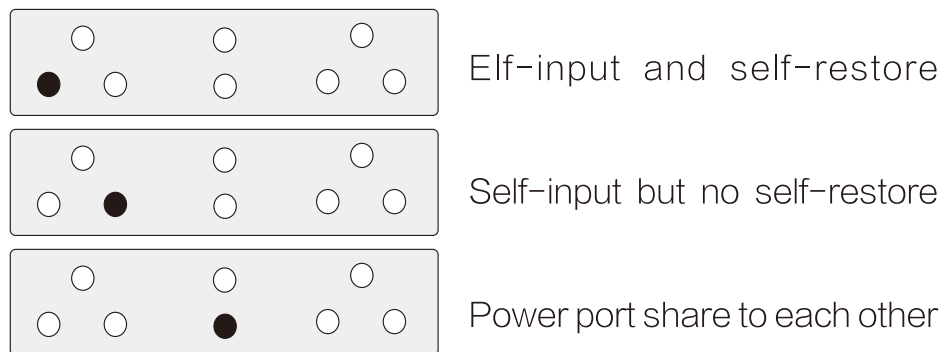

## 6.SETTING MODE OF Y-702 CONTROLLER

- parameter setting

Press "Manual/Auto" button ten times to start setting. Press "A closing" or "B closing" to select.

- parameter modify

After enter the above mentioned panel, press "Manual/Auto" button to start/cancel modifying

(digit start to flash), press "A closing" to increase and press "B closing" to decrease.

- save&exit setting

When the setting action completed, and the digit is still flashing, press "All OFF" button to save and exit(Only this way can save the modification).

Y- 702 parametric code, range and factory default

NO.	Parametric code	Para Name	Range	Factory Default
1	U270	Common over-voltage	200-300	270
2	u165	Common under-voltage	100-200	165
3	n270	Standby over-voltage	200-300	270
4	n165	Standby under-voltage	100-200	165
5	┐	Delay time of cutting to common power	0-240	1
6	┘	Delay time of cutting to standby power	0-240	1
7	q	Time-consuming of turn on the generator	0-240	5
8	d	Time-consuming of turn off the generator	0-240	5
9	P	Brightness control	0-10	8
10	E	Ats working mode	0-2	0
11	□	Programmable output	0-8	0
12	J	Local host	1-32	1
13	b	Baud rate	1=2400 2=4800 3=9600 4=19200	3
14	H	Reset to defaults	(0- 3) 3= Reset to defaults	0

ATTENTION:select H=003 will restore the ATS,this operation may produce a error of voltage display in range  $\pm 10V$ .

The define of programmable output F/F1:

Programmable output	Setting range(0-8)	Default output
F/F1	0=enable generator normally-closed display 1=fire control feedback display 2=normal power fault display 3=standby power fault display 4=auto mode display 5=manual mode display 6=changeover failed display 7=normal power enabled display 8=standby power enabled display	0

● ATS working mode

E-0 self-input and self restore

E-1 self-input and no self restore(details refer to P19 function introduction)

E-2 normal port and standby port share to each other(details refer to P19 function introduction)

## 7 ■ Y-700/702 CONTOUR AND INSTALLATION SIZE

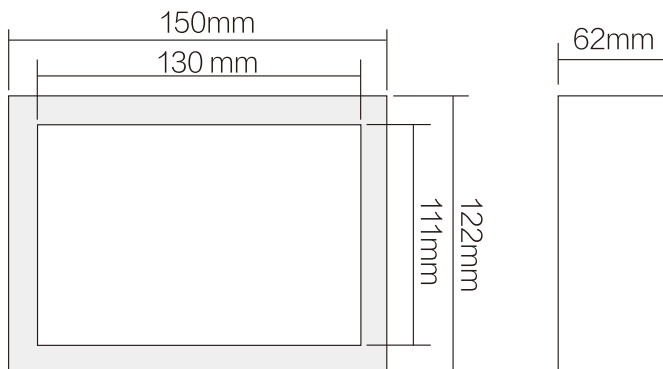

The size of hole:130mm\*111mm  
 Overall dimensions:150mm\*122mm

## 8.Y-700/702 FUNCTION OF EACH TERMINAL

R-	R+	GND	R1	485A (+)	485B (-)	EGND
----	----	-----	----	-------------	-------------	------

- R-&R+:DC9V-36V active fire control input enabled
- GND&R1:short circuit,passive fire control unit enabled
- 485A&485B:RS485--communication terminal,EGND--Frame Ground

Communication protocol parameters:

Local host:1(1-32,can be modified)

Baud rate:9600bps

Data bit:8

Parity bit:none

Stop bit:1

M3	M4	L2	A2	A2	B2	C2	N2	T2	T1	F2	F1	F	N1	C1	B1	A1	A1	L1	M2	M1
1	2	3	4	5	6	7	8	9	10	11	12	13	14	15	16	17	18	19	20	21

- M3,M4:standby power passive closing auxiliary output, outputting time depends on ATS Model; about 3 seconds within magnet exciting coil, Electric type ATS can be more than10 seconds.
- L2:standby power active closing feedback input, only limited to phase A/B/C
- A2:standby power phase A output, feedback to the closing standby power.
- A2,B2,C2,N2:standby power three-phase&four-wire input
- T1,T2:All off signal output, can be active or passive depends on ATS model, when equipped with PC class three sections ATS, it is 220AC active output, and it is passive when equipped with seclusion type ATS.
- F2,F1,F:in Y-701 controller,F1 and F are starting generator signal output; in Y-702 controller, F1 and F are programmable output.
- A1,B1,C1,N1:normal power three-phase&four-wire input
- A1:A phase normal output, feedback to closing normal power.
- L1:normal power active closing feedback input, only limited to phase A/B/C.
- M1,M2:normal power passive closing auxiliary output, outputting time refers to M3&M4.

## 9.COIL FIGURE OF CONTROLLER

**!** The phase sequence of normal power and standby power should be same.

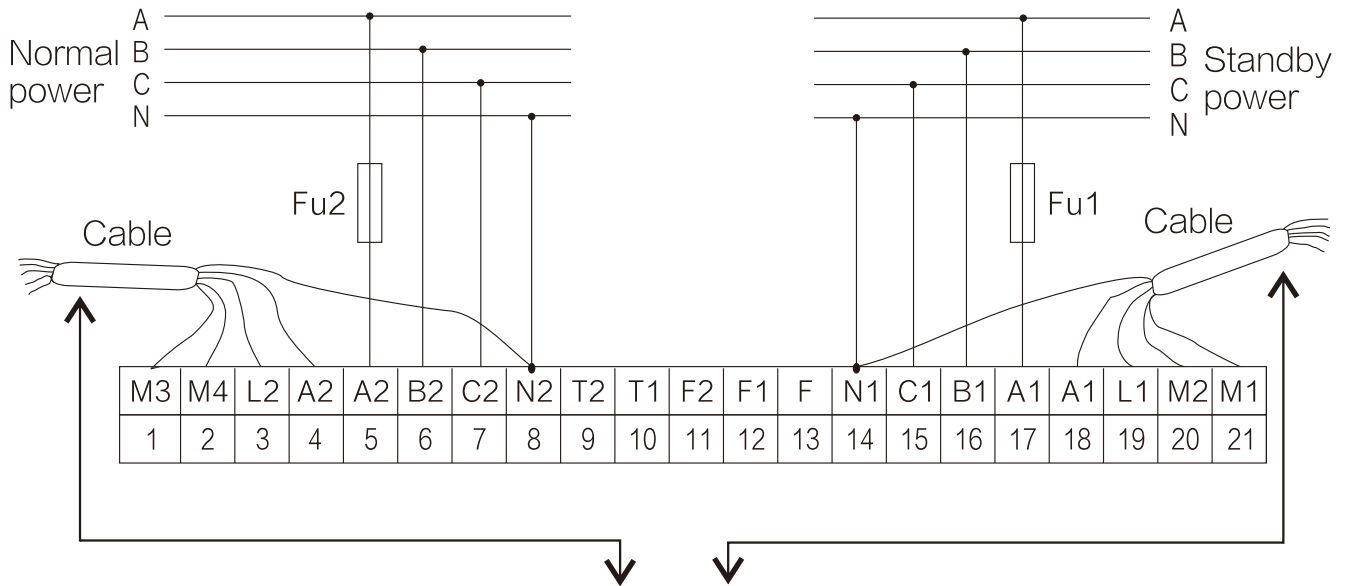

### ATTENTION:

- 1.Attention:controller is equipped with the cable while out of factory,cable should be right connected refer to the mark A/B/C/N.
- 2.FU1/FU2 normal power and standby power insurance tube,the value will change depends on ATS model.  
 while equipped with GA type ATS:FU1/FU2=2A  
 while equipped with C , N , S type ATS,FU1/FU2=10A  
 while equipped with N , Q type ATS,FU1/FU2=16A

**ZHEJIANG LVMA IMPORT AND EXPORT CO., LTD.**

Mobile: 18157733126

E-mail: [info@lvma-ele.com](mailto:info@lvma-ele.com)

Http: [www.lvma-ele.com](http://www.lvma-ele.com)

ADD: No. 6688, Xuyang Road, Chengdong Street,  
Yueqing City, Wenzhou City, Zhejiang Province  
(9th Floor, Building 5, Headquarters Economic Park)

Suggest sending the manual to the final user!