

INVERTER GASOLINE GENERATOR

USER MANUAL

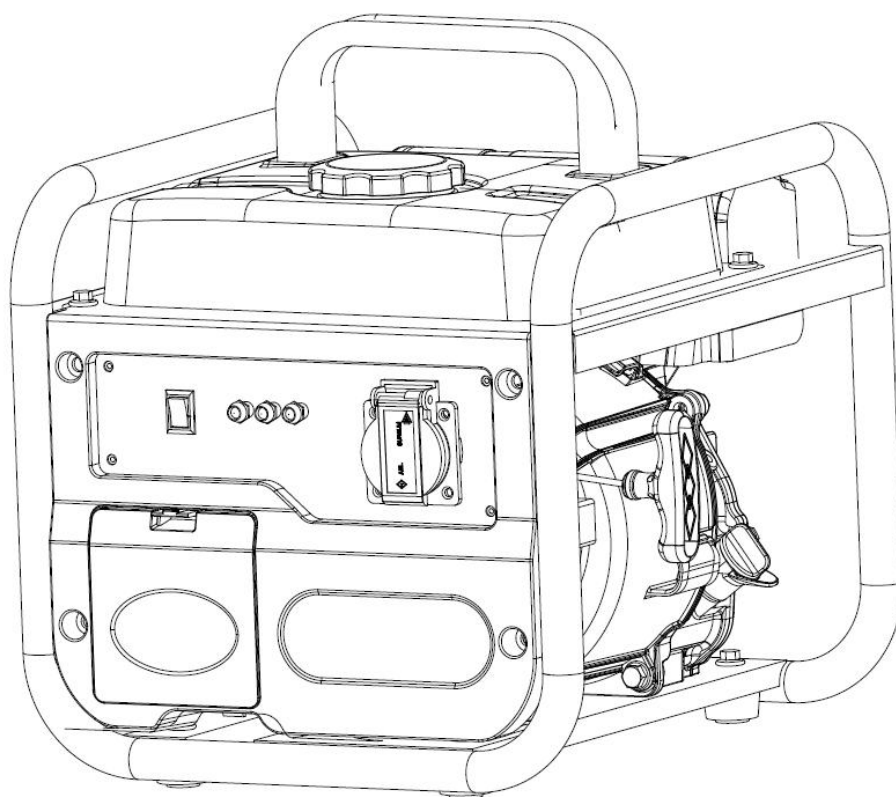

Model: EYG1000iB

Original instructions

1. SAFETY INFORMATION

WARNING!

The generator sets are designed to give safe and dependable service if operated according to instructions. Read and understand this owner's manual before operating your generator. You can help

Prevent accidents by being familiar with your generator's controls, and by observing safe operating procedures.

- Engine exhaust gases are toxic. Do not operate the generating set in unventilated rooms. When installed in ventilated rooms, additional requirements for fire and explosion protection shall be observed.
- Don't operate in the wet condition.
- Don't directly connect to the household power supply.
- Please keep it 1m at least far away from the inflammable materials.
- Protect children by keeping them at a safe distance from the generating set,
- Fuel is combustible and easily ignited. Do not refuel during operation. Do not refuel while smoking or near naked flames.
- Do not spill fuel.
- Some parts of the internal combustion engine are hot and may cause burns. Pay attention to the warnings on the generating set.

Operator Responsibility

- Know how to stop the generator quickly in case of emergency.
- Understand the use of all generator controls, output receptacles, and connections.
- Be sure that anyone who operates the generator receives proper instruction.
- Do not let children operate the generator without parental supervision.

Carbon Monoxide Hazards

- Exhaust contains poisonous carbon monoxide, a colorless and odorless gas. Breathing exhaust can cause loss of consciousness and may lead to death.
- If you run the generator in an areas that is confined, or even partially enclosed, the air you breathe could contain a dangerous amount of exhaust gas. To keep

exhaust gas from accumulating, provide adequate ventilation.

Electric Shock Hazards







- Electrical equipment including lines and plug connections should be free from nudity.
- Electrical equipment (including lines and plug connections) should not be defective.
- The generating set must not be connected to other power sources, such as the power company supply mains. In special cases where stand-by connection to existing electrical systems is intended, it shall only be performed by a qualified electrician who has to consider the differences between operating equipment using the public electrical supply network and operating the generating set. In accordance with this part of ISO 8528 the differences shall be stated in the instruction manual.
- Precaution against electrical shock depends on circuit breakers specially matched to the generating set. If the circuit breakers require replacement they must be replaced with a circuit breaker having identical ratings and performance characteristics.
- Due to high mechanical stressed only tough rubber-sheathed flexible cable (in accordance with IEC 60245-4) or the equivalent should be used.
- The circuit breakers should be matched with the generator equipment.
- If the circuit breakers require replacement, they must be replaced with a circuit breaker having identical ratings and performance characteristics.
- Don't operate the generator before grounding.
- If using extension lines, the requirement should be met as following: for 1.5mm², the line should not be exceeded 60m; for 2.5mm², the line not exceeded 100m.

NOTICE!

When you operate the generator set, please put on protections such as gloves to protect your hands from high temperature.

Safety sign

⚠ WARNING

-  Not to refuel when operating.
-  Electrical hazard.
-  Exhaust gas is poisonous; do not operate in an unventilated area [Carbon monoxide (CO) danger].
-  Read the operator's instruction manual.
-  Avoid connecting the generator to commercial power outlet.
-  Be sure to ground(earth) the generator.

2. SAFETY LABEL LOCATION

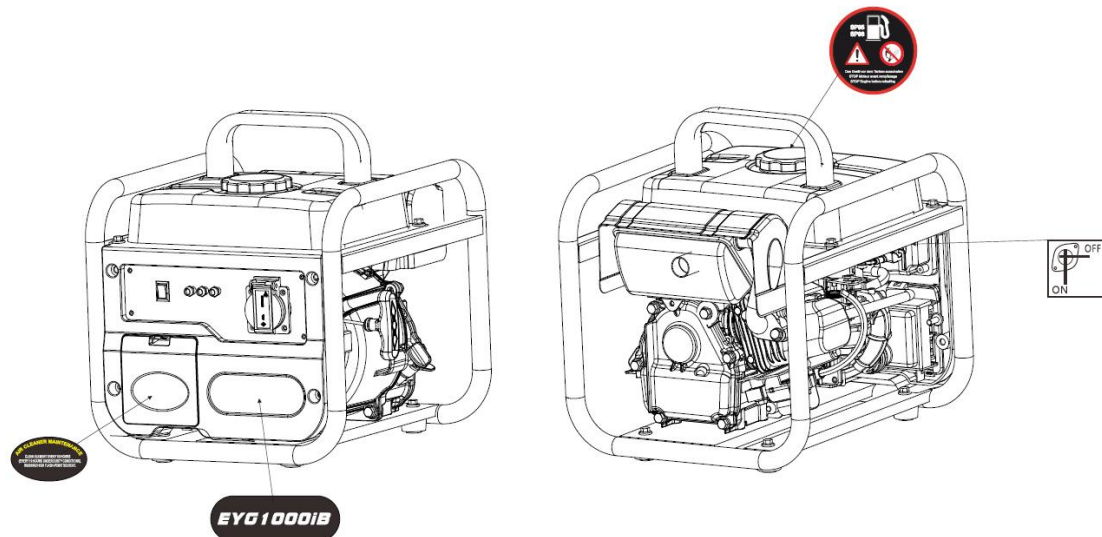

3. COMPONENTS IDENTIFICATION

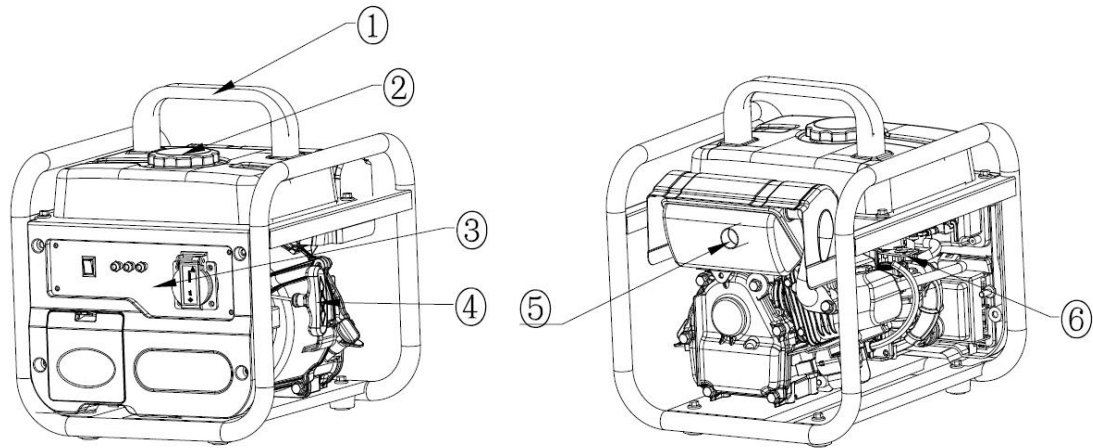

- ① Carrying handle
- ③ Control panel
- ⑤ Muffler

- ② Fuel tank cap
- ④ Recoil starter
- ⑥ Throttle switch

3.1 Control panel

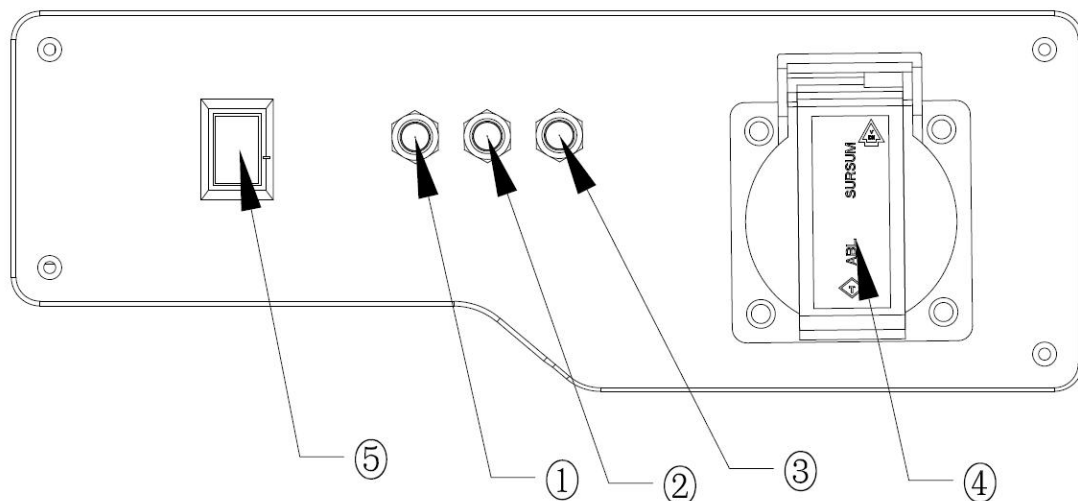

- ① Oil warning light
- ③ AC pilot light
- ⑤ Engine switch

- ② Overload indicator light
- ④ AC receptacle

4. CONTROL FUNCTION

4.1 Oil warning light (red)

- When the oil level falls below the lower level, the oil warning light ① comes on and then the engine stops automatically. Unless you refill with oil, the engine will not start again.

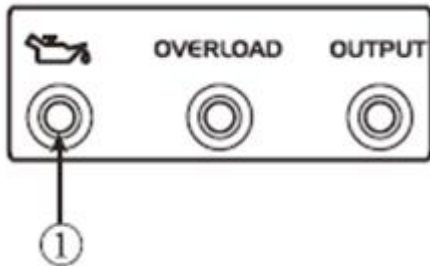

Tip: If the engine stalls or does not start, turn the engine switch to “ON” and then pull the recoil starter.

If the oil warning light flickers for a few seconds, the engine oil is insufficient. Add oil and restart.

4.3 Overload indicator light (Red)

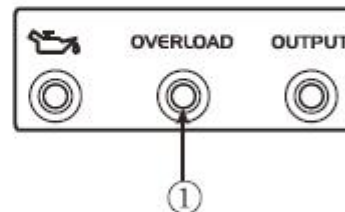

The overload indicator light ① comes on when an overload of a connected electrical device is detected, the inverter control unit overheats, or the AC output voltage rises. Then, the AC protector will trip, stopping power generation in order to protect the generator and any connected electric devices. The AC pilot light (Green) will go off and the overload indicator light (Red) will stay on, but the engine will not stop running.

When the overload indicator light comes on and power generation stops, proceed as follows:

1. Turn off any connected electric devices and stop the engine.
2. Reduce the total wattage of connected electric devices within the rated output.
3. Check for blockages in the cooling air inlet and around the control unit. If any blockages are found, remove.
4. After checking, restart the engine.

Tip: The overload indicator light may come on for a few seconds at first when using electric devices that require a large starting current, such as a compressor or a submersible pump. However, this is not a malfunction.

4.4 AC pilot light (Green)

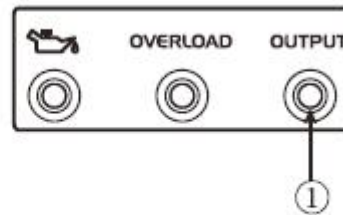

The AC pilot light ① comes on when the engine starts and produces power.

⚠ CAUTION

Reduce the load of the connected electric device below the specified rated output of the generator if the DC protector turns off. If the DC protector turns off again, stop using the device immediately and consult our company authorized dealer.

4.5 Fuel tank cap

Remove the fuel tank cap by turning it counterclockwise.

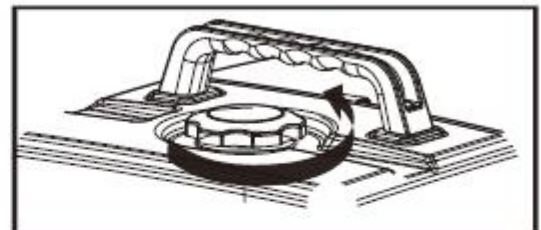

4.6 Ground (Earth) terminal

Ground (Earth) terminal ① connects the earth line for prevention of electric shock. When the electric device is earthed, always the generator must be earthed.

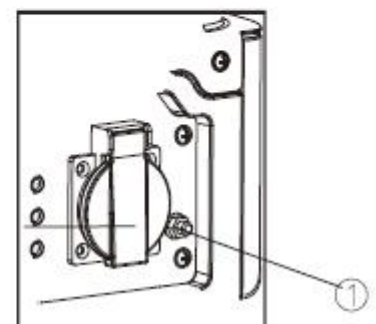

5. PRE-OPEARTION CHECK

Caution

Be sure the generator is on the leveled surface and the generator is stopped.

1) Check Oil Level

NOTICE

The generator has been shipped without engine oil. Do not start the engine till fill with the sufficient engine oil.

1. Place the generator on a level surface.
2. Remove the oil filler cap ①
3. Fill the specified amount of the recommended engine oil, and then install and tighten the oil filler cap.
4. Install the cover and tighten the screws.

Recommended engine oil: SAE 15W-40

Recommended engine oil grade: API Service SE type or higher

Engine oil quantity: 0.28 L

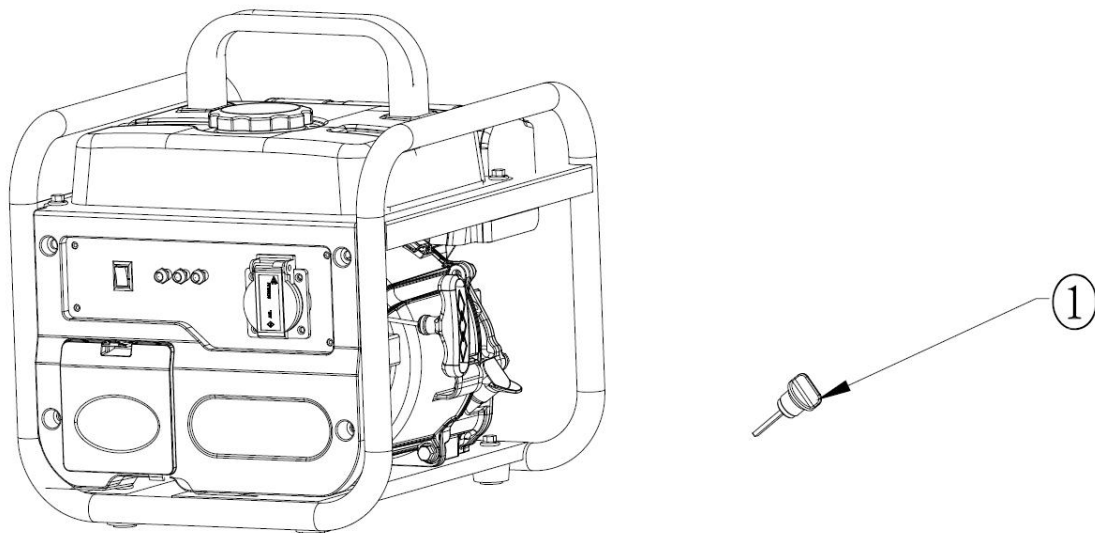

Note

- Before the engine oil reduces below the safety margin, Low Oil Alert System will close the engine automatically. The Oil Alert Indicator Light (yellow) will be on.
- To avoid the inconvenience caused by unexpected stopping, it is still advisable to check the engine oil level regularly.

2) Check fuel level

Fuel recommendation: use unleaded gasoline (Re-search Octane Number of 92 or higher, Pump Octane Number of 86 or higher)

Never use stale or contaminated gasoline or an oil/gasoline mixture,

Avoid getting dirt or water into the fuel tank.

Do not use a mixture gasoline containing ethanol or methanol; otherwise, it will seriously damage the engine.

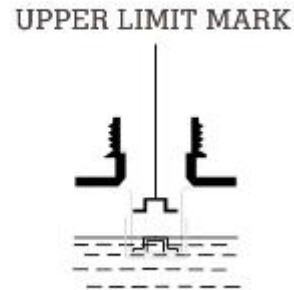
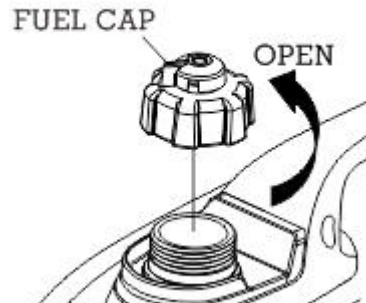

Caution

- Gasoline is extremely explosive and flammable.
- Around the refueling area and fuel storage area, prohibit smoking and firing.
- Do not overfill the fuel tank (no fuel above the upper limit mark). After refueling, make sure the fuel cap is closed properly and securely.
- Do not make fuel spill from fuel tank. (No residual fuel around the neck of tank, before starting engine)
- Avoid contacting with skin or breathing the fuel vapor.
- KEEP OUT OF REACH OF CHILDREN.

Fuel capacity: 2.8L

3) Check Air Cleaner

Check the Air Cleaner Element to be sure it is clean and in good condition.

Loose the cover screw, and remove the maintenance cover. Press the tab on the top of the Air Cleaner. Remove the Air Cleaner cover. Check the Element.

Check, clean or replace it, if necessary.

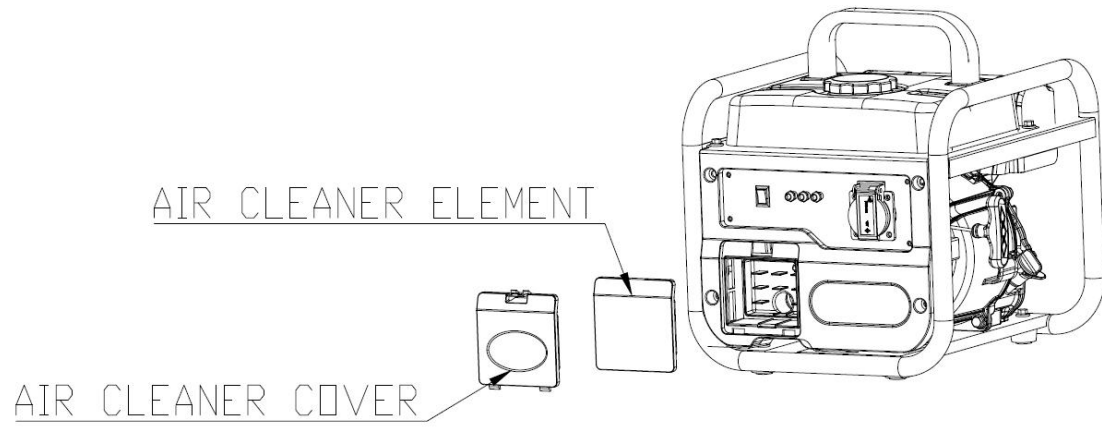

Note

- Do not run engine without air Cleaner element, otherwise that makes engine abrasion.

6. OPERATION

WARNING

- Never operate the engine in a closed area or it may cause unconsciousness and death within a short time. Operate the engine in a well ventilated area.
- Before starting the engine, do not connect any electric devices.

NOTICE

- The generator has been shipped without engine oil. Do not start the engine till fill with the sufficient engine oil.
- Do not tilt the generator when adding engine oil. This could result in overfilling and damage to the engine.

TIP:

The generator can be used with the rated output load at standard atmospheric conditions.

“Standard atmospheric conditions”

Ambient temperature 25°C

Barometric pressure 100kPa

Relative humidity 30%

The output of the generator varies due to change temperature, altitude (lower air pressure at higher altitude) and humidity.

The output of the generator is reduced when the temperature, the humidity and the altitude are higher than standard atmospheric conditions.

Additionally, the load must be reduced when using in a confined areas, as generator cooling is affected.

6.1 Starting the engine

1. Turn the engine switch to “ON” ①

2. Pull the choke out ②

TIP: The choke is not required to start a warm engine. Push the choke in.

3. Pull slowly on the recoil starter until it is engaged, then pull it briskly.

TIP: Grasp the carrying handle firmly to prevent the generator from falling over when pulling the recoil starter.



4. After the engine starts, warm up the engine until the engine does not stop when push the choke in to "OFF"

6.2 Stopping the engine

TIP: Turn off any electric devices.

1. Disconnect any electric devices.
2. Turn the engine switch to "OFF"

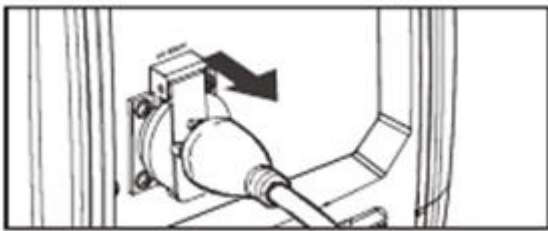
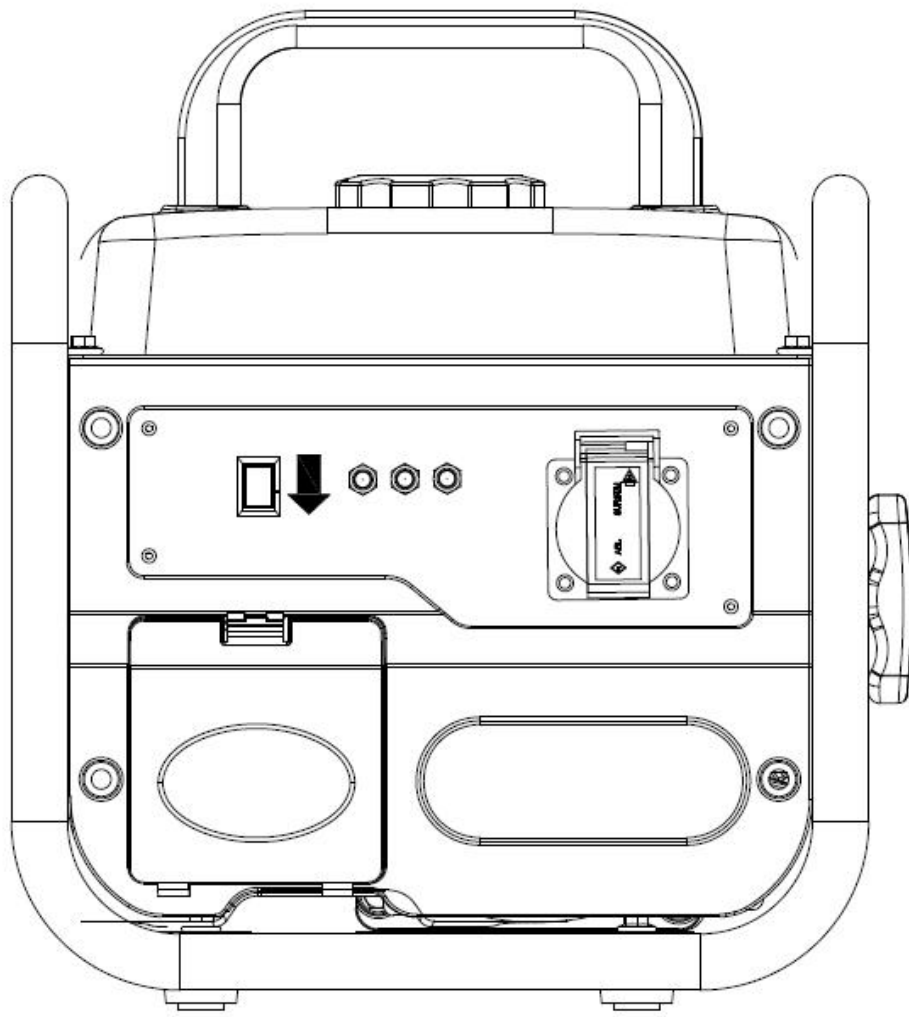

6.3 Alternating Current (AC) connection

⚠ WARNING

Be sure any electric devices are turned off before plugging them in.

NOTICE

- Be sure all electric devices including the lines and plug connections are in good condition before connection to the generator.
- Be sure the total load is within generator rated output.
- Be sure the receptacle load current is within receptacle rated current.

TIP: Make sure to ground (Earth) the generator. When the electric device is earthed, always the generator must be earthed.



1. Start the engine.
2. Plug in to AC receptacle.
3. Make sure the AC pilot light is on.
4. Turn on any electric devices.

TIP:

If the generator is connected to multiple loads or electricity consumers, please remember to first connect the one with the highest starting current, and last connect the one with the lowest starting current.

6.4 Application range

When using the generator, make sure the total load is within rated output of a generator. Otherwise, generator damage may occur.

AC			
Power factor	1	0.8–0.95	0.4–0.75 (Efficiency 0.85)
1kW	≤ 1000W	≤ 800W	≤ 340W

TIP:

- Application wattage indicates when each device is used by itself.
- The simultaneous usage of AC and DC power is possible but total wattage should not exceed the rated output.

EX:

Generator rated output		1kW
Frequency	Power factor	
AC	1.0	≤ 1000W
	0.8	≤ 800W

- The overload indicator light ① comes on when total wattage exceeds the application range. (See page 10 for more details.)

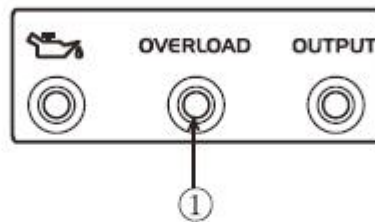

NOTICE

- Do not overload. The total load of all electrical appliances must not exceed the supply range of the generator. Overloading will damage the generator.
- When supplying precision equipment, electronic controllers, PCs, Electronic computers, microcomputer based equipment or battery chargers, keep the generator a sufficient distance away to prevent electrical interference from the engine. Also ensure that electrical noise from the engine does not interfere with any other electrical devices located near the generator.
- If the generator is to supply medical equipment, advice should first be obtained from the manufacturer, a medical professional or hospital.
- Some electrical appliances or general-purpose electric motors have High starting currents, and cannot therefore be used, even if they lie within the supply ranges given in the above table. Consult the equipment manufacturer for further advice.

Carburetor Modification for High Altitude Operation

At high altitude, the standard carburetor air-fuel mixture will be too rich. Performance will decrease, and fuel consumption will increase. A very rich mixture will also foul the spark plug and cause hard starting.

If the generator operates at high altitude, change the main-nozzle or adjust the idling-screw of carburetor.

If the generator always operates at altitude above 1,000 meters, contact with an authorized servicing to modify the carburetor.

Generator set output power should be modified according to the altitude and ambient temperature. The correction factor refers to 13-1.

Caution

- If the carburetor has been modified for high altitude operation, the air-fuel mixture will be too lean for low altitude use. Operation at low altitude may cause the engine to overheat and result in serious engine damage. The carburetor needs return to original specifications.

7. MAINTENANCE

The engine must be properly maintained to ensure its operation be safe, economy and trouble-free, as well as eco-friendly.

In order to keep your gasoline engine in good working condition, it must be periodically serviced. The following maintenance schedule and routine inspection procedures must be carefully followed:

Items	Frequency	Frequency			
		Each time	First 1 month or first 20hrs of operation	Thereafter, every 3 months or every 50hrs of operation	Every year or every 100 hrs of operation
Engine oil	Check-Refill	✓			
	Replace		✓	✓	
Reduction gear oil(if equipped)	Oil level check	✓			
	Replace		✓	✓	
Air filter element	Check	✓			
	Clean		✓		
	Replace			✓	
Deposit Cup (if equipped)	Clean				✓
Spark Plug	Check-adjust				✓
	Replace	Every year or 250 hrs of operation			
Spark arrester	Clean			✓	
Idling (if equipped)*	Check-adjust				✓
Valve clearance *	Check-adjust				✓
Fuel tank & fuel filter *	Clean				✓
Fuel line	Check	Every 2 years(change if necessary)			
Cylinder head, piston	Clean up carb-on *	$< 225\text{cc}$, Every 125hrs $\geq 225\text{cc}$, Every 250hrs			
* These items should be maintained and repaired by our authorized dealer, unless the owner has appropriate tools and is proficient with mechanical maintenance.					

NOTICE

- If the gasoline engine frequently works under high temperature or heavy load, change the oil every 25 hours.
- If the engine frequently work under dusty or other severe circumstances, clean the air filter element every 10 hours; If necessary, change the air filter element every 25 hours.
- The maintenance period and the exact time (hour), the one which comes first should govern.
- If you have missed the scheduled time to maintain your engine, do it as soon as possible.

⚠ WARNING

Stop the engine before servicing. Put the engine on a level surface and remove the spark plug cap to prevent the engine from starting.

Do not operate the engine in a poorly ventilated room or other enclosed area. Be sure to keep good ventilation in working area. The exhaust from the engine may contain poisonous CO, inhalation can cause shock, unconsciousness and even death.

7.1 Spark plug inspection

The spark plug is important engine components, which should be checked periodically.

1. Remove the spark plug cap ①, and Insert the tool ② through the hole from the outside of the cover.
2. Insert the handlebar ③ into the tool ② and turn it counterclockwise to remove the spark plug.
3. Check for discoloration and remove the carbon. The porcelain insulator around the center electrode of spark plug should be a medium-to-light tan color.
4. Check the spark plug type and gap.

Standard Spark Plug: A5RTC

Spark Plug Gap: 0.6-0.8mm

TIP: The spark plug gap should be measured with a wire thickness gauge and, If

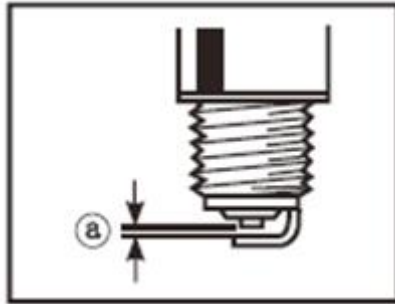

necessary, adjusted to specification.

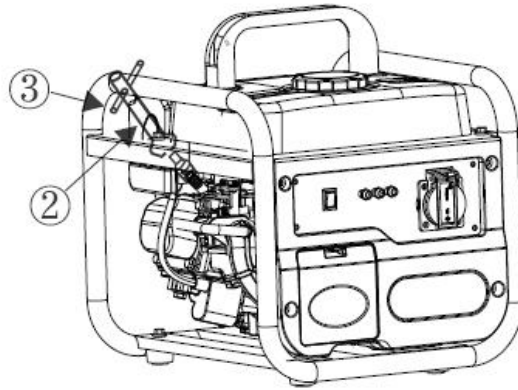
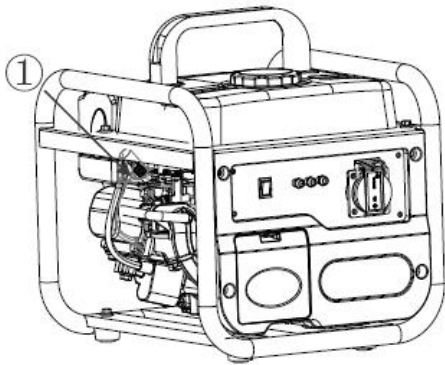

5. Install the spark plug.

Spark Plug Torque: 12.5 N*m (1.25kgf*m, 9 lbf*ft)

TIP: If a torque wrench is not available when installing a spark plug, a good estimate of the correct torque is 1/4-1/2 turn past finger tight. However, the spark plug should be tightened to the specified torque as soon as possible.

6. Install the spark plug cap and spark plug cover.

7.2 Carburetor adjustment

The carburetor is a vital part of the engine. Adjusting should be left to our company authorized dealer with the professional knowledge, specialized data, and equipment to do so properly.

7.3 Engine oil replacement (refer to 5.2)

⚠ WARNING

Avoid draining the engine oil immediately after stopping the engine. The oil is hot and should be handled with care to avoid burns.

1. Place the generator on a level surface and warm up the engine for several minutes. The stop the engine and turn the engine switch, fuel switch knob to “OFF”.
2. Remove the screws and then remove the cover.
3. Remove the oil filler cap .
4. Place an oil pan under the engine. Tilt the generator to drain the oil completely.
5. Replace the generator on a level surface.

NOTICE

Do not tilt the generator when adding engine oil. This could result in overfilling and damage to the engine.

6. Add engine oil to the upper level.

Recommended engine oil: SAE 10W-40

Recommended engine oil grade: API Service SE type or higher

Engine oil quantity: 0.28L

7. Wipe the cover clean, and wipe up any spilled oil.

NOTICE

Be sure no foreign material enters the crankcase.

8. Install the oil filler cap.

9. Install the cover and tighten the screws.

7.4 Air filter

1. Remove the air filter case cover

2. Remove the foam element .

3. Wash the foam element in solvent and dry it.

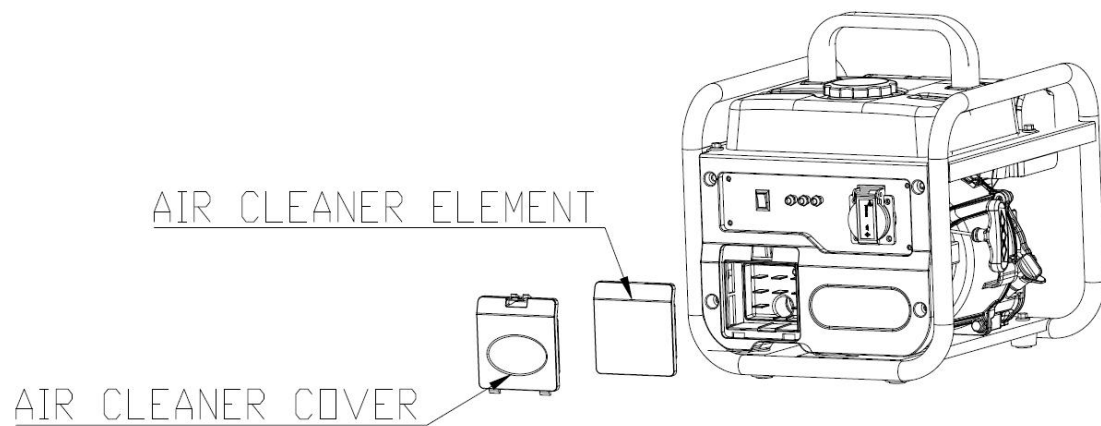

4. Oil the foam element and squeeze out excess oil.

The foam element should be wet but not dripping.

NOTICE

Do not wring out the foam element when squeezing it. This could cause it to tear.

5. Insert the foam element into the air filter case.

TIP: Be sure the foam element sealing surface matches the air filter so there is no air leak.

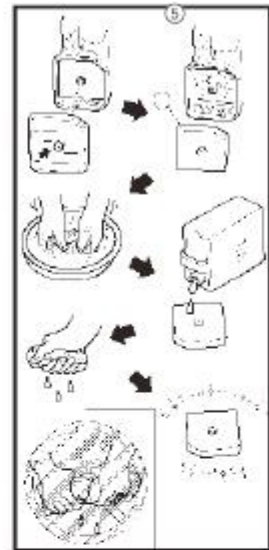

The engine should never run without the foam element; excessive piston and cylinder wear may result.

6. Install the air filter case cover in its original position.

7.5 Muffler screen

WARNING

The engine and muffler will be very hot after the engine has been run. Avoid touching the engine and muffler while they are still hot with any part of your body or clothing during inspection or repair.

I

7.6 Fuel tank filter

WARNING

Never use the gasoline while smoking or in the vicinity of an open flame.

1. Remove the fuel tank cap and filter.
2. Clean the filter with gasoline.
3. Wipe the filter and install it.
4. Install the fuel tank cap.

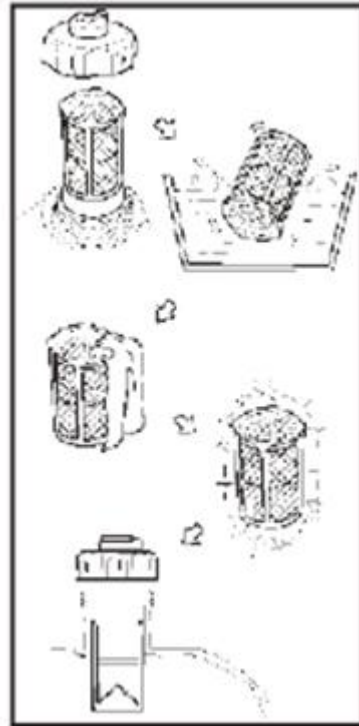

Be sure the fuel tank cap is tightened securely.

7.7 Fuel filter

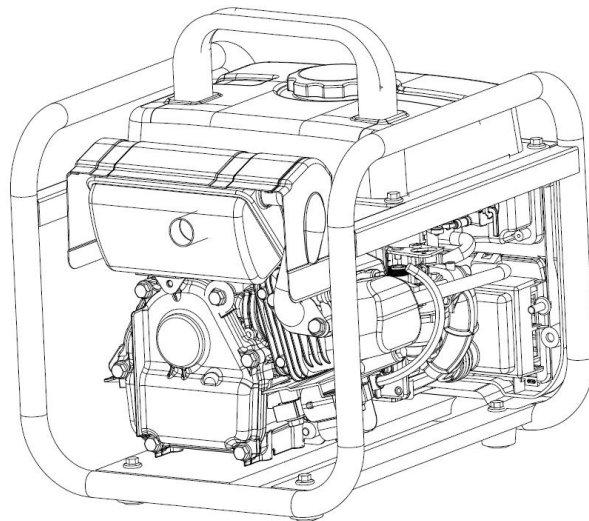

1. drain the fuel
2. Hold and move up the clamp, then take off the hose from the tank.
3. Take out the fuel filter
4. Clean the filter with gasoline.
5. Dry the filter and put it back into tank,
6. Install the hose and clamp, then open the fuel valve to check whether it is leak.
7. Install the cover and tighten the screws.

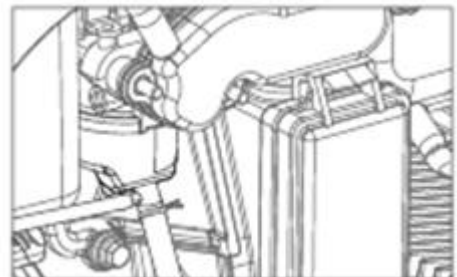

8. STORAGE

Long term storage of your machine will require some preventive procedures to guard against deterioration.

8.1 Drain the fuel

1. Stop the engine.(See page 22).
2. Remove the fuel tank cap, remove the filter . Extract the fuel from the fuel tank into an approved gasoline container. Then, install the fuel tank cap.

WARNING

Fuel is highly flammable and poisonous. Check “SAFETY INFORMATION” (See page 5) carefully.

NOTICE

Immediately wipe off spilled fuel with a clean, dry, soft cloth, since fuel may deteriorate painted surfaces or plastic parts.

3. Start the engine (See Page 21) and leave it run until it stops. The engine stops in approx. 20 minutes. Time by running out of fuel.

TIP:

- Do not connect with any electrical devices. (unloaded operation)
- Duration of the running engine depends on the amount of the fuel left in the tank.

■

4. Remove the screws, and then remove the cover.
5. Drain the fuel from the carburetor by loosening the drain screw on the carburetor float chamber.
6. Turn the engine switch to “OFF”.
7. Tighten the drain screw.
8. Install the cover and tighten the screws.
9. Turn the fuel switch to “OFF” after the engine has completely cools down.

8.2 Engine

Perform the following steps to protect the cylinder, piston ring, etc. from corrosion.

1. Remove the spark plug, pour about one table- spoon of SAE 15W-40 into the spark plug hole and reinstall the spark plug. Recoil start the engine by turning over several times (with the engine switch off) to coat the cylinder walls with oil.
2. Pull the recoil starter until you feel compression. Then stop pulling. (This prevents the cylinder and valves from rusting).
3. Clean exterior of the generator. Store the generator in a dry, well-ventilated place, with the cover placed over it.

9. TROUBLE SHOOTING

When the engine can not be started:

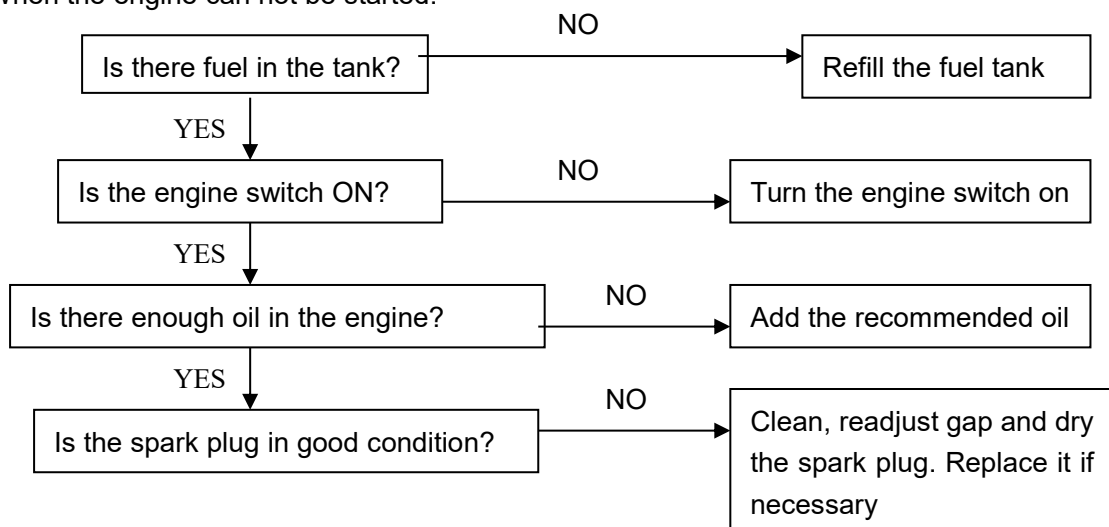

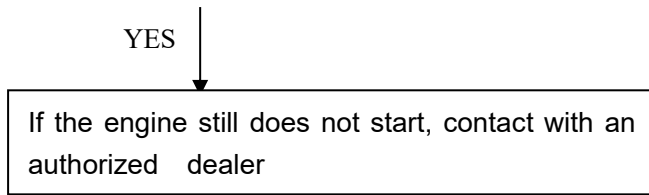

Appliance does not operate :

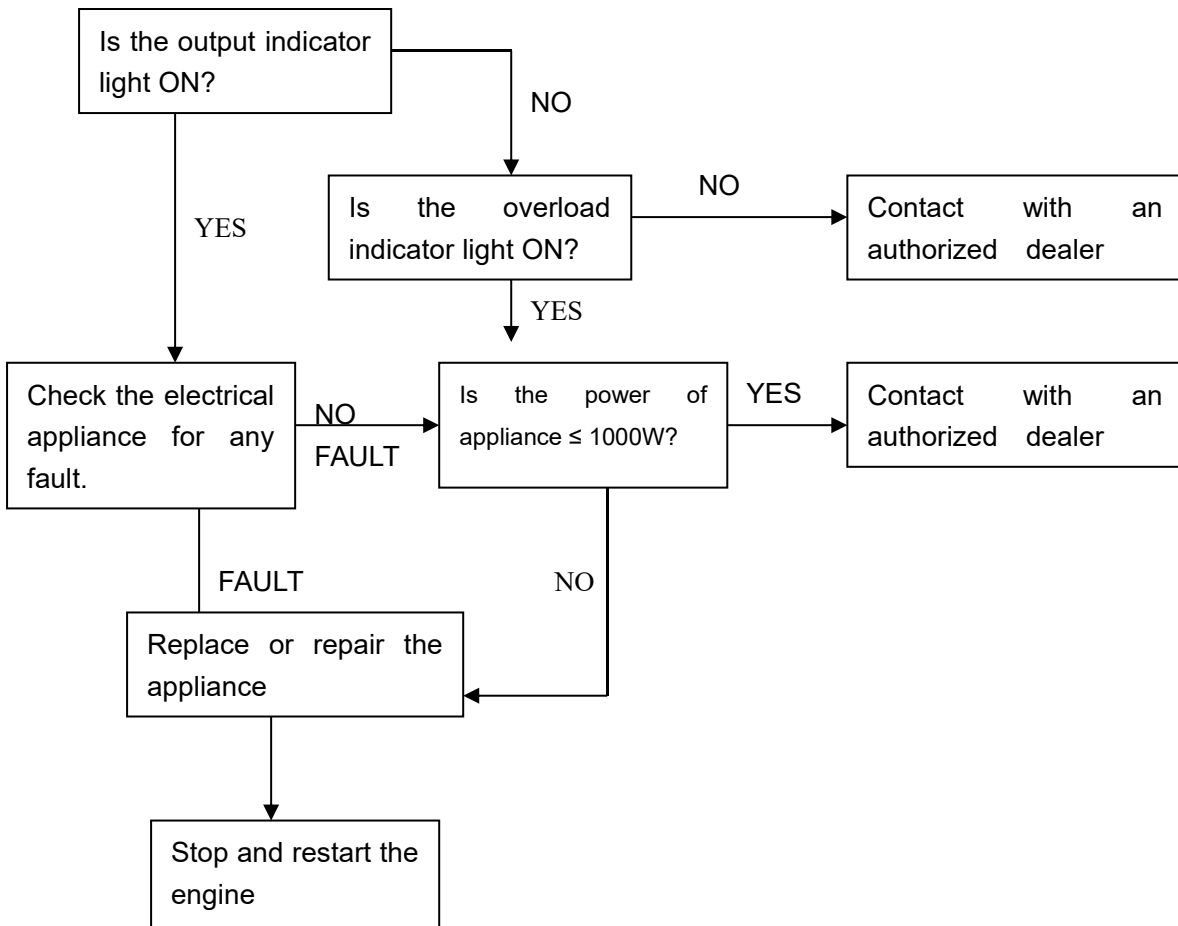

DC receptacle without any electricity :

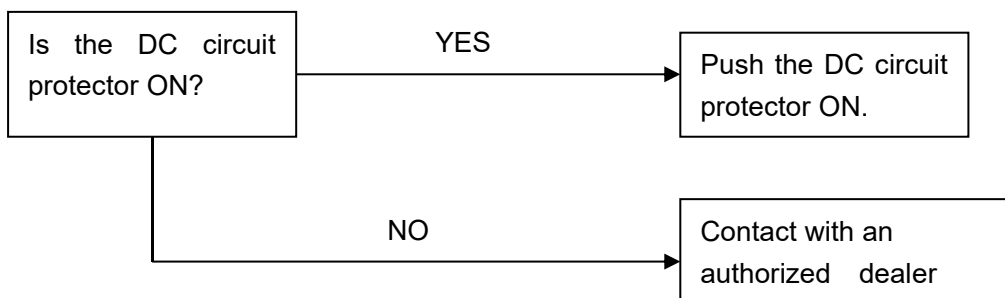

10. TECHNICAL SPECIFICATIONS

	Specifications	Parameters
ENGINE	Model	LY145F
	Type	Single cylinder, four stroke, forced air cooling, overhead valve
	Engine Displacement (cm ³)	56
	Bore*Stroke (mm)	45*36
	Compression Ratio	8.5:1
	Rated Power(kW/min ⁻¹)	1.45/4800
	Ignition System	Full transistor
	Start System	Recoil starter
	Fuel Type	Gasoline without lead
	Oil Model	SAE 15W-30
GENERATOR	Model	EYG1000iB
	Rated Frequency (Hz)	50
	Rated Voltage (V)	230
	Rated Current (A)	4.3
	Rated Speed (min ⁻¹)	5000
	Rated Output Power COP (kW)	1.0
	Max. Output Power (kW)	1.1
GENERATOR SET	Fuel Tank Volume (L)	2.8
	Continuous Running Time (h)	4.0 (Rated power)
	Fuel Consumption (g/(kW.h))	≤530
	Working Ambient Temperature(°C)	-15~40
	Max. Altitude(m)	0~1000
	Dimensions (L*W*H) (mm)	340*305*290mm
	Net Weight(kg)	11.5

11. ELECTRICAL DIAGRAMS

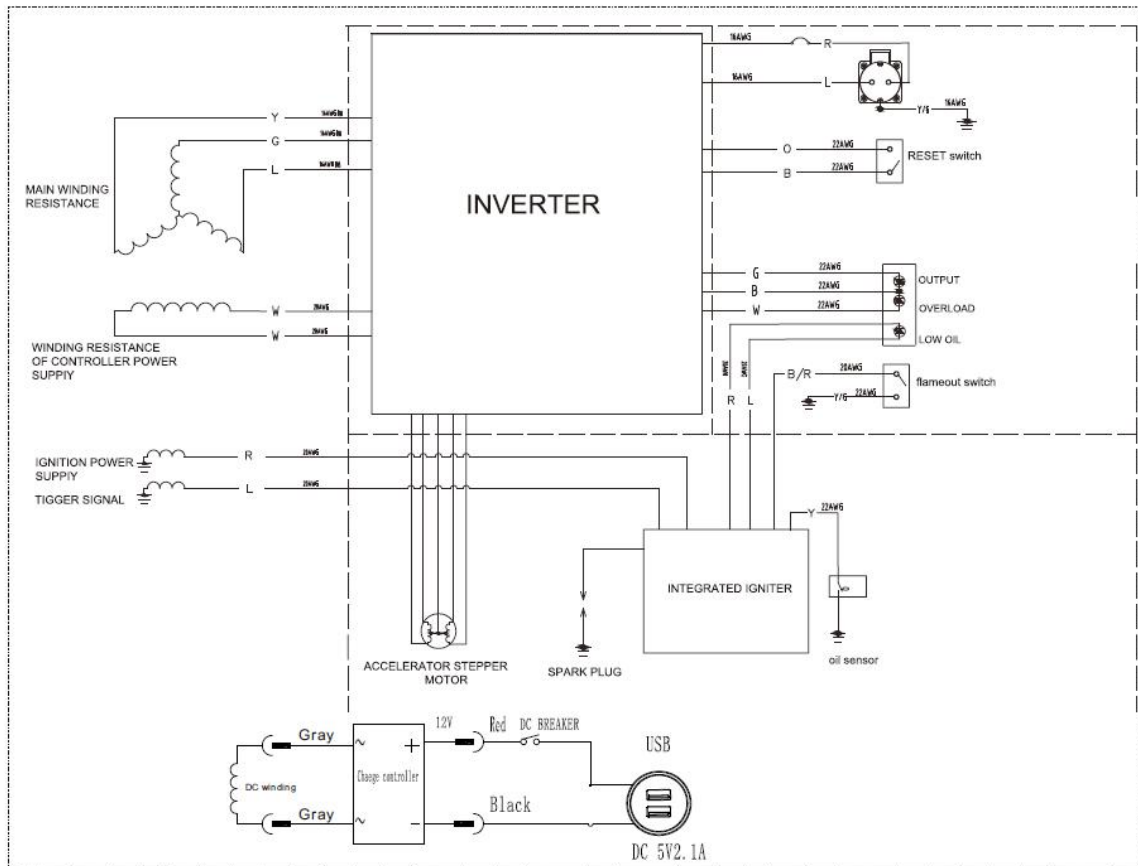

12. ENVIRONMENT CORRECTION

The standard condition of rated power output:

Altitude: 0m

Ambient temperature: 25°C

Relative humidity: 30%

Factor of environment correction:

Altitude (m)	Ambient temperature °C				
	25	30	35	40	45
0	1	0.98	0.96	0.93	0.90
500	0.93	0.91	0.89	0.87	0.84
1000	0.87	0.85	0.82	0.80	0.78
2000	0.75	0.73	0.71	0.69	0.66
3000	0.64	0.62	0.6	0.58	0.56
4000	0.54	0.52	0.5	0.48	0.46

Note: Relative humidity 60% correction factor C-0.01;

Relative humidity 80% correction factor C-0.02;

Relative humidity 90% correction factor C=0.03;
Relative humidity 100% correction factor C=0.04;

Example:

Rated power (P_N) 1.0KW generator, Altitude: 1000m, Ambient temperature: 35°C,
Relative humidity: 80%

$$P = P_N * (C - 0.02) = 1.0 * (0.82 - 0.02) = 0.8KW$$



EC DECLARATION OF CONFORMITY



For the following machinery:

Product name: Inverter Gasoline Generator

Function: low power generator set

Type: Gasoline

Model number: EYG1000iB

is herewith confirmed to fulfill all the relevant provisions of

Machinery Directive (2006/42/EC)

Electromagnetic Compatibility Directive (2014/30/EU)

Noise Emission Directive by equipment for use outdoors (2000/14/EC + 2005/88/EC)

Conformity Assessment Procedure: 2000/14/EC, amended by 2005/88/EC- Annex VI

- Measured sound power level: 90 dBA
- Guarantee sound power level: 93 dBA

and the following harmonized standard have been complied with:

EN ISO 8528-13:2016

EN 61000-6-1:2019

EN 55012:2007+A1