

# Technical Data Sheet (TDS)

## Marble PLA

The Eryone-Marble PLA filament is a 3D printing material that can simulate the appearance of marble. It has a smooth and delicate surface, with an elegant texture and no obvious layer lines. Due to its realistic look, it has become an ideal choice for many artistic pieces, presenting a natural and authentic effect, resembling real marble. It is widely used in sculptures, artworks, and architectural style printed works.

### Part I: Suggests Printing Parameters

Parameter	Set up
Nozzle temperature	200°C-220°C
Bed temperature	55-70°C
Bed material	glass, PEI, spring steel plate
Bottom printing temperature	200°C-220°C
Sealed printing	Open Printing/closed printing
Printing speed	30-80mm/s
Drying conditions	50°C-60°C , 6h

### Part II: Physical Properties Of Materials

Property	Testing Method	Unit	Typical Value
Density(g/cm <sup>3</sup> at 21.5 ° C)	ASTM D792 (ISO 1183, GB/T 1033)	g/cm <sup>3</sup>	1.25
Vicat Softening Temperature(° C)	ASTM D1525 (ISO 306 GB/T 1633)	°C	57
Heat distortion temperature(° C)	ASTM D648 0.45MPa	°C	53
Melt Index(g/10 min)	220 ° C, 10kg 240 ° C, 2.16 kg	g/10min	32

### Part III: Mechanical Properties of Printed Samples

Property	Test conditions	Test standards	unit	Typical Value
Tensile strength X-Y	50mm/min	GB/T 1040.4	MPa	53.8
Elastic modulus X-Y	50mm/min	GB/T 1040.1-2006	MPa	1730.9
Elongation at break X-Y	50mm/min	GB/T 1040.4	%	2.1
Tensile strength X-Z	50mm/min	GB/T 1843	MPa	22.8
Elastic modulus X-Z	50mm/min	GB/T 1040.1-2006	MPa	1683.4
Elongation at break X-Z	50mm/min	GB/T 1040.4	%	1.7
Bending strength	2mm/min	GB/T 9341	MPa	88.9
Bending modulus	2mm/min	GB/T 9341	MPa	3025.7
Charpy Impact strenght	2.75J	GB/T 1843	kJ/m2	3.8

Note: All splines are printed under the following conditions: printing temperature=210° C, printing speed=80mm/s, base plate 60 ° C, filling=100%, nozzle diameter=0.4mm

## TENSILE TESTING SPECIMEN

ISO 527,GB/T 1040

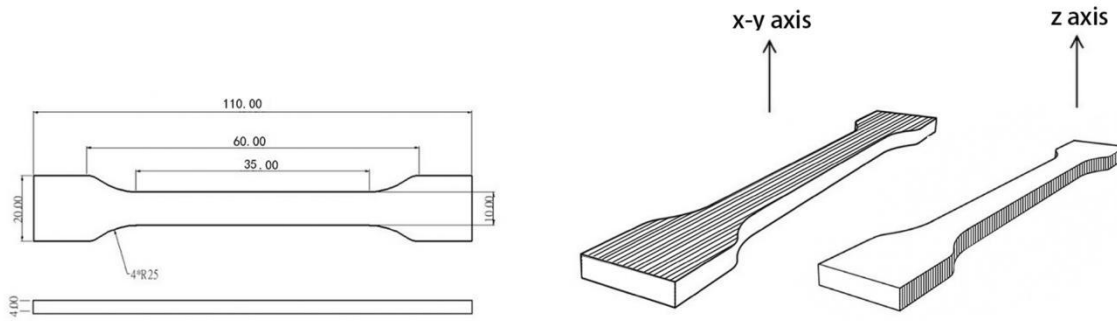

## FLEXURAL TESTING SPECIMEN

ISO 178,GB/T 9341

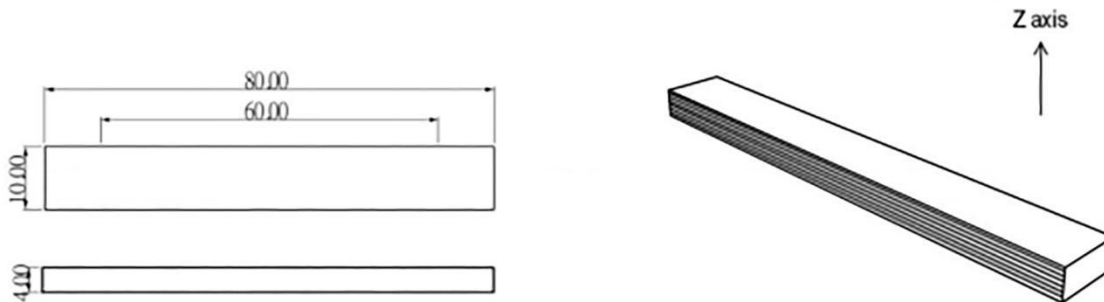

## IMPACT TESTING SPECIMEN

ISO 179,GB/T 1043

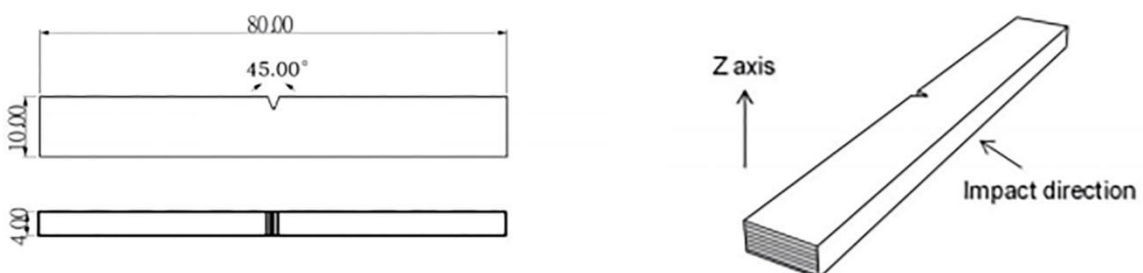

## Disclaimers

The values given in this data table are for reference and comparison only. They should not be used for design specifications or quality control. The actual value may vary depending on the printing conditions. The final performance of printed components depends not only on the material, but also on the component design, environmental conditions, printing conditions, and so on. Product specifications are subject to change without prior notice.