

Technical Data Sheet (TDS)

Hyper Speed TPU

ERYONE high-speed TPU filament is a highly efficient printing material, boasting a printing speed approximately three times that of conventional TPU, significantly improving printing efficiency. This material is not only soft yet highly tough and wear-resistant, but also boasts excellent impact resistance for shock absorption and maintains its performance despite repeated bending. It is ideal for use in mobile phone cases and other electronic device protective covers. Proper drying of the material and increased retraction distance are required to minimize stringing. Its hardness is 95A.

Part I: Suggests Printing Parameters

Parameter	Set up
Nozzle temperature	200-220 °C
Bed temperature	0-60°C
Bed material	glass, PEI, spring steel plate
Bottom printing temperature	200-220 °C
Sealed printing	Supports open/closed printing
Printing speed	≤300mm/s
Drying conditions	70°C, 8H

Part II: Physical Properties of Materials

Property	Testing Method	Unit	Typical Value
Density(g/cm ³ at 21.5 ° C)	ASTM D792 (ISO 1183, GB/T 1033)	g/cm ³	1.22
Heat distortion temperature(° C)	ASTM D648 0.45MPa	°C	/
Glass transition temperature (° C)	DSC, 10 ° C/min	°C	/
Melt Index(g/10 min)	210 ° C, 2.16 kg	g/10min	36

Part III: Mechanical Properties of Printed Samples

Property	Test conditions	Test standards	unit	Typical Value
Tensile strength X-Y	50mm/min	GB/T 1040.4	MPa	27.3
Elastic modulus X-Y	50mm/min	GB/T 1040.1-2006	MPa	27
Elongation at break X-Y	50mm/min	GB/T 1040.4	%	501.3
Tensile strength X-Z	50mm/min	GB/T 1843	MPa	22
Elastic modulus X-Z	50mm/min	GB/T 1040.1-2006	MPa	/
Elongation at break X-Z	50mm/min	GB/T 1040.4	%	/
Bending strength	2mm/min	GB/T 9341	MPa	/
Bending modulus	2mm/min	GB/T 9341	MPa	/
Charpy Impact strenght	2.75J	GB/T 1843	kJ/m2	120

Note: All splines are printed under the following conditions: printing temperature=220 ° C, printing speed=100mm/s, base plate 55° C, filling=100%, nozzle diameter=0.4mm

TENSILE TESTING SPECIMEN

ISO 527,GB/T 1040

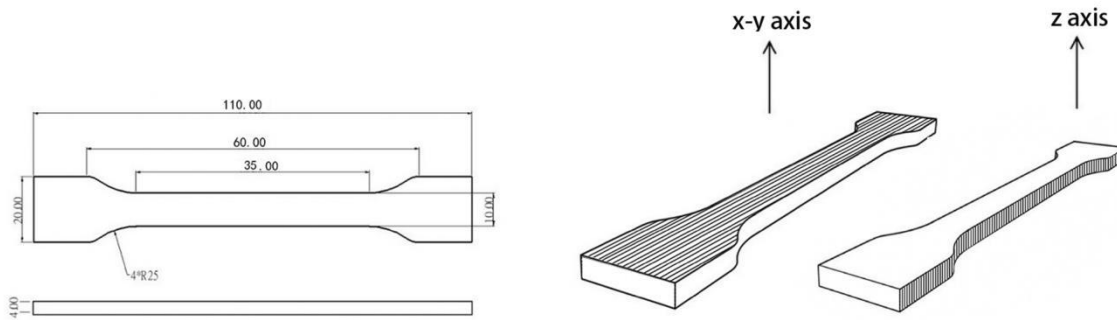

FLEXURAL TESTING SPECIMEN

ISO 178,GB/T 9341

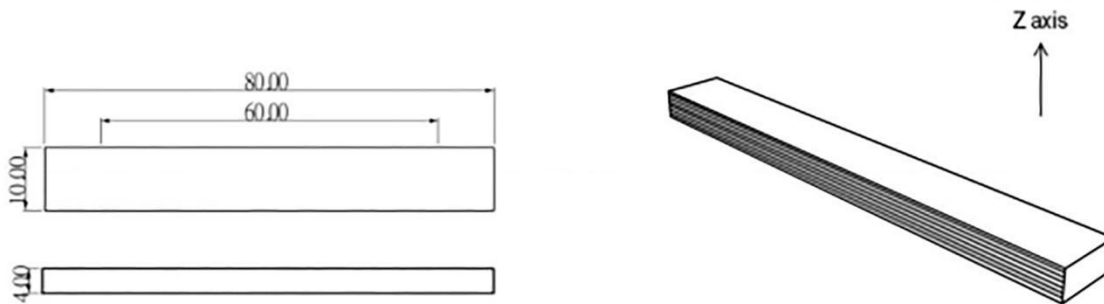

IMPACT TESTING SPECIMEN

ISO 179,GB/T 1043

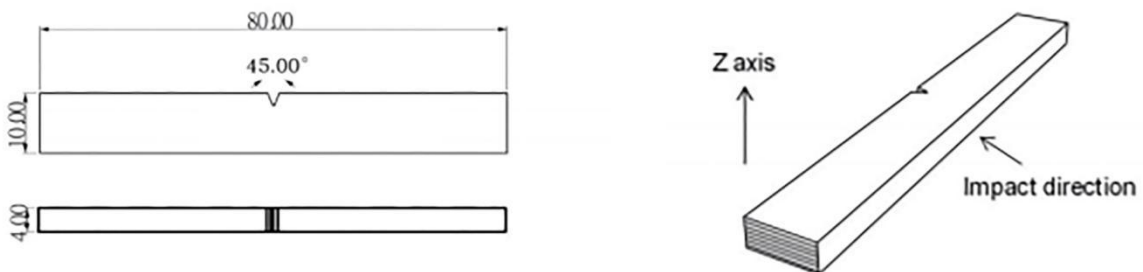

Disclaimers

The values given in this data table are for reference and comparison only. They should not be used for design specifications or quality control. The actual value may vary depending on the printing conditions. The final performance of printed components depends not only on the material, but also on the component design, environmental conditions, printing conditions, and so on. Product specifications are subject to change without prior notice.