

WARNING!

Children have died from furniture tipover. Fixed wall device have been included with this product;you must install the fixed wall device according to these instructions in order to minimize the risk of furniture.If you have any questions about this product or the Fixed wall device , please contact us immediately.

Never allow children to climb or hang on furniture,including drawers or cabiner doors.

In addition to installing the restrains,to help prevent tip-over.





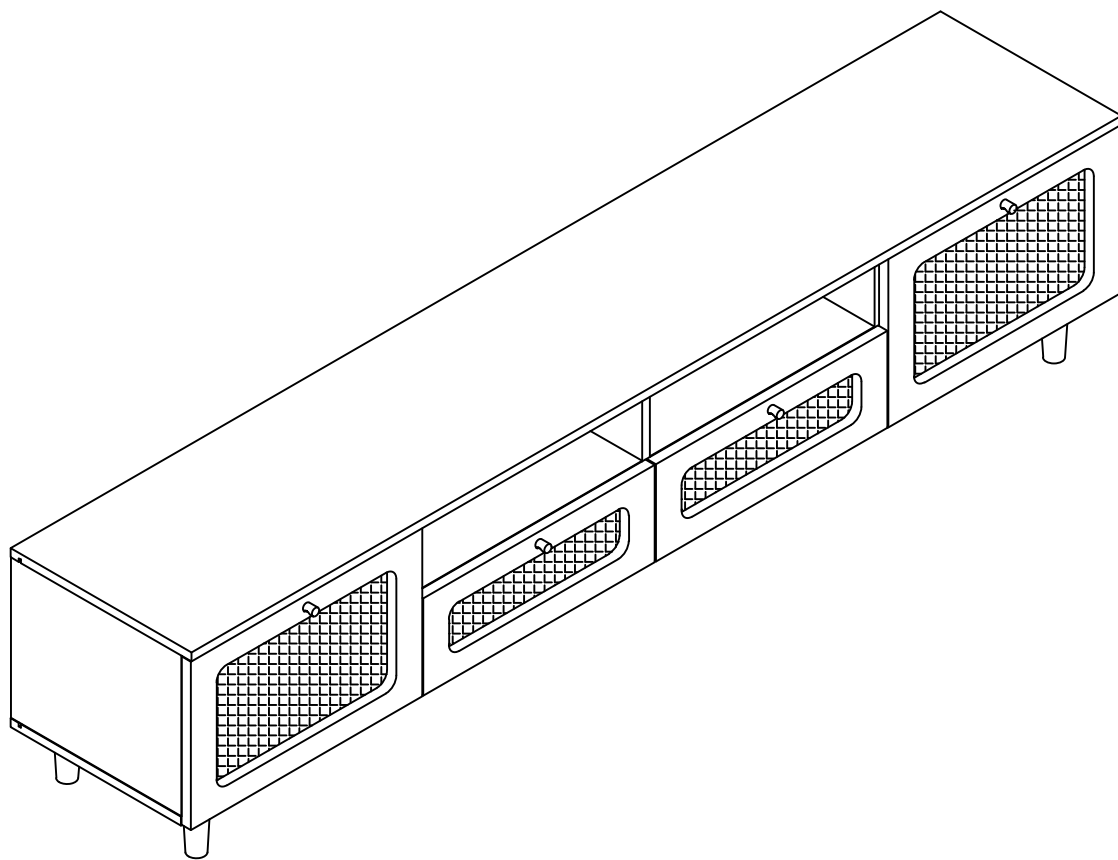



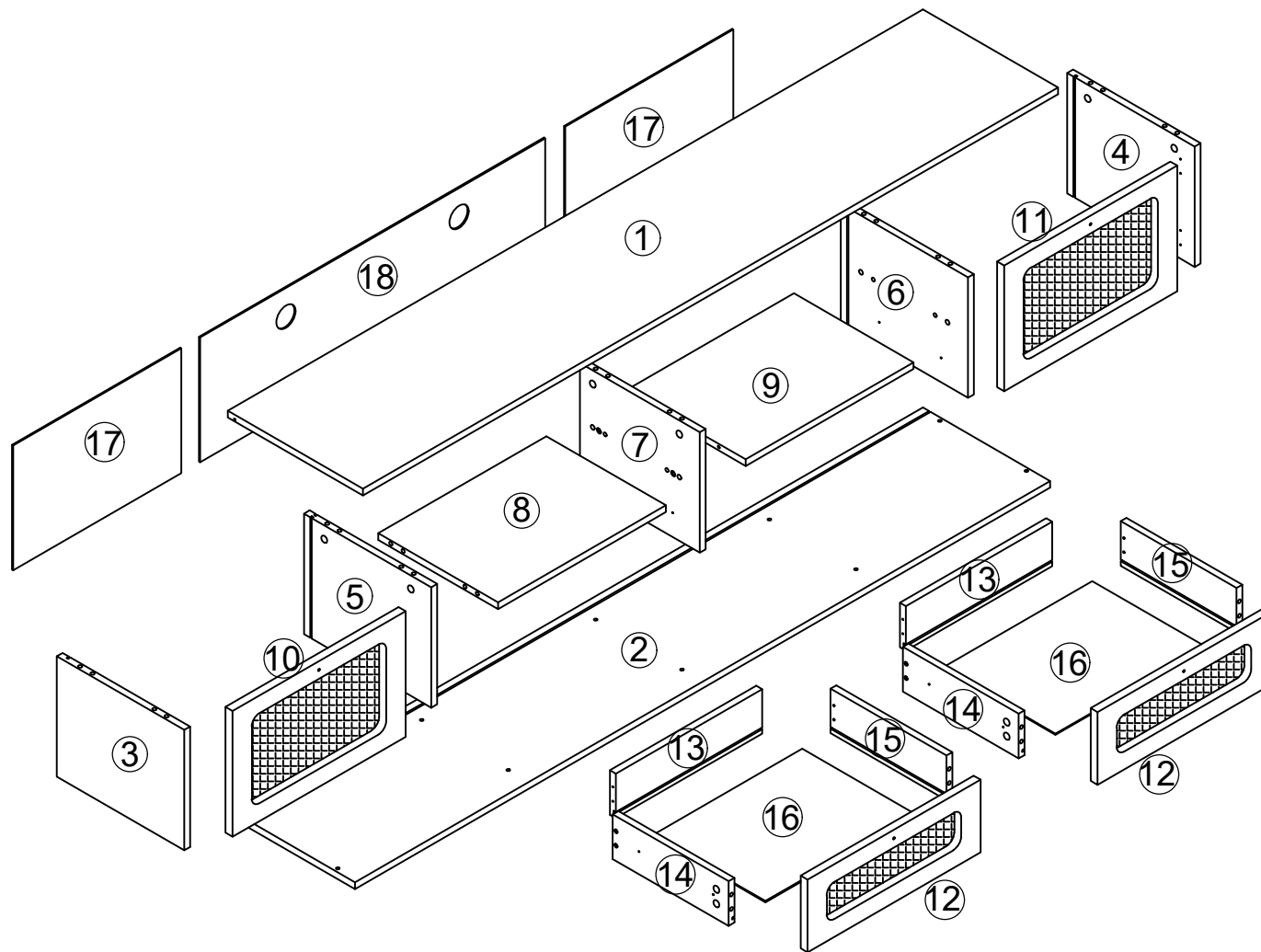

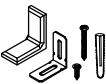

1. Never put a TV or other heavy objects on top of this product.
2. Do not stand on the product.

! WARNING	
	Children have died from furniture tipover. To reduce the risk of furniture tipover: <ul style="list-style-type: none">• ALWAYS install tipover restraint provided.• NEVER put a TV on this product.• NEVER allow children to stand, climb or hang on drawers, doors, or shelves.• NEVER open more than one drawer at a time.• Place heaviest items in the lowest drawers.• Do not defeat or remove the drawer interlock system. <p><i>This is a permanent label. Do not remove!</i></p>
	

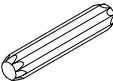

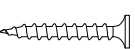
JMY2208130

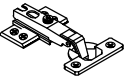

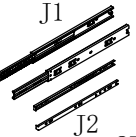
<p>K</p>  <p>4PCS</p>	<p>L</p> <p>4*20</p>  <p>4PCS</p>	<p>M</p>  <p>6PCS</p>	<p>N</p> <p>95mm</p>  <p>6PCS</p>	<p>O</p>  <p>2PCS</p>	<p>A</p>  <p>24PCS</p>	<p>B</p>  <p>24PCS</p>	<p>C</p> <p>8*40</p>  <p>16PCS</p>	<p>D</p> <p>3.5*14</p>  <p>70PCS</p>	<p>E</p> <p>3.5*35</p>  <p>8PCS</p>	<p>F</p> <p>7*50</p>  <p>12PCS</p>	<p>G</p>  <p>4PCS</p>	<p>H</p>  <p>14PCS</p>	<p>I</p> <p>3*12</p>  <p>14PCS</p>	<p>J</p> <p>300mm</p>  <p>J1 2PCS J2</p>
--	--	--	--	---	--	---	---	---	---	---	--	---	---	---

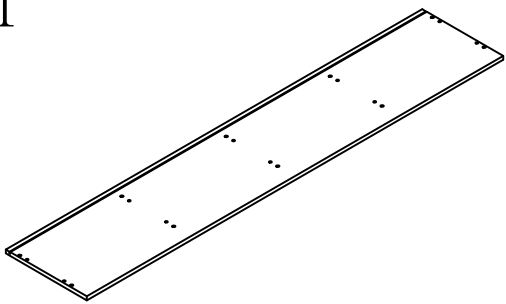
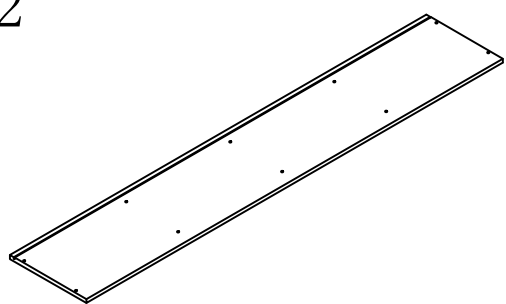
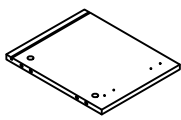
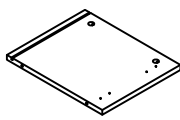
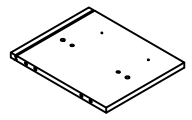
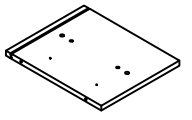
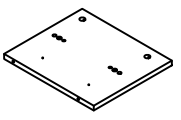
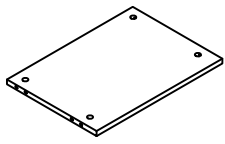
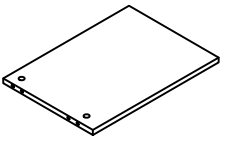
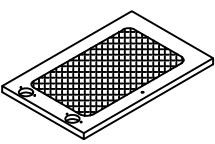
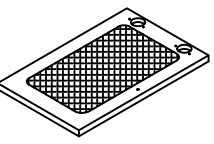
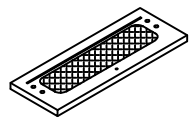
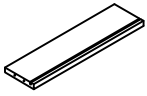
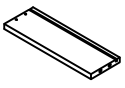
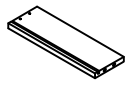
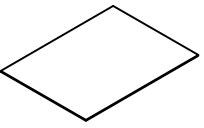
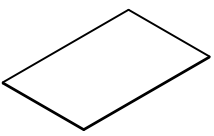
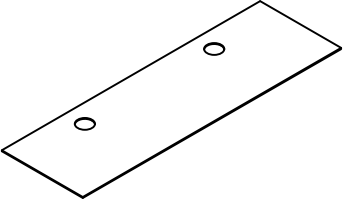
<p>1</p>  <p>1800*350 1PS</p>	<p>2</p>  <p>1800*350 1PS</p>	<p>3</p>  <p>270*330 1PS</p>	<p>4</p>  <p>270*330 1PS</p>	
<p>5</p>  <p>270*330 1PS</p>	<p>6</p>  <p>270*330 1PS</p>	<p>7</p>  <p>270*310 1PS</p>	<p>8</p>  <p>435*310 1PS</p>	
<p>9</p>  <p>435*310 1PS</p>	<p>10</p>  <p>448*282 1PS</p>	<p>11</p>  <p>448*282 1PS</p>	<p>12</p>  <p>448*163 2PS</p>	<p>13</p>  <p>379*100 2PS</p>
<p>14</p>  <p>300*100 2PS</p>	<p>15</p>  <p>300*100 2PS</p>	<p>16</p>  <p>389*294 2PS</p>	<p>17</p>  <p>435.5*280 2PS</p>	<p>18</p>  <p>893*280 1PS</p>



Hardware installation demonstration

NOTE: Please make sure "A" hardware tightened and can't be pulled out!

I

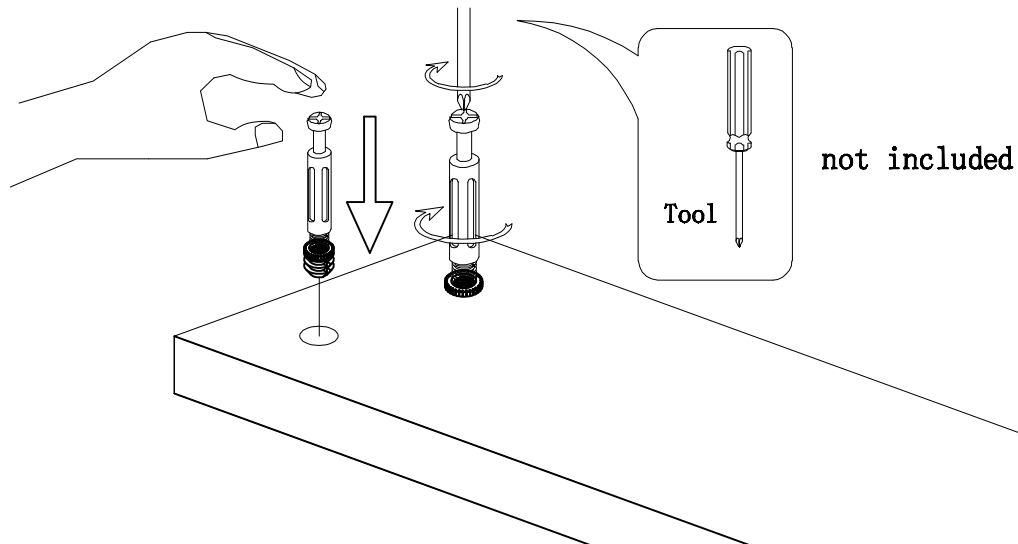

II

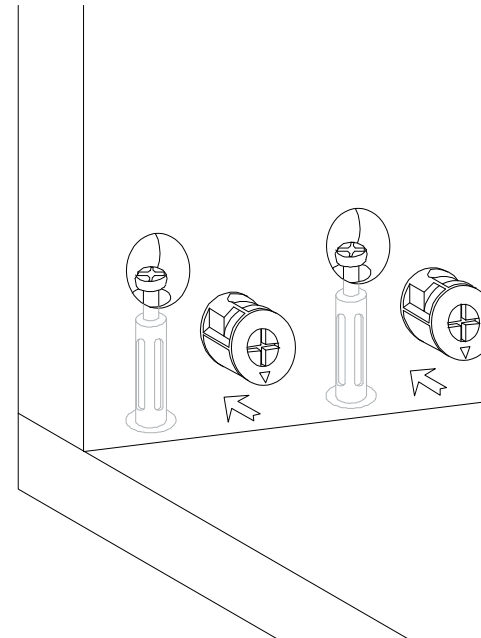

III

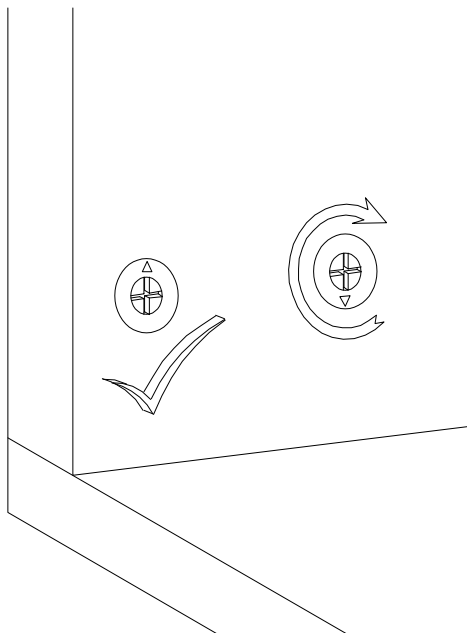

IV



Scan QR code for assembly video

1

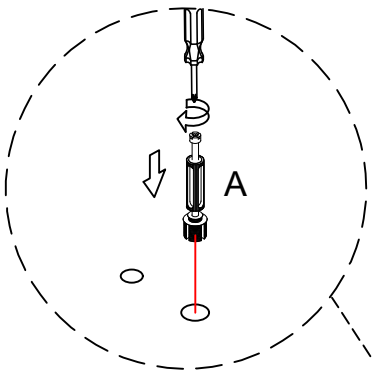
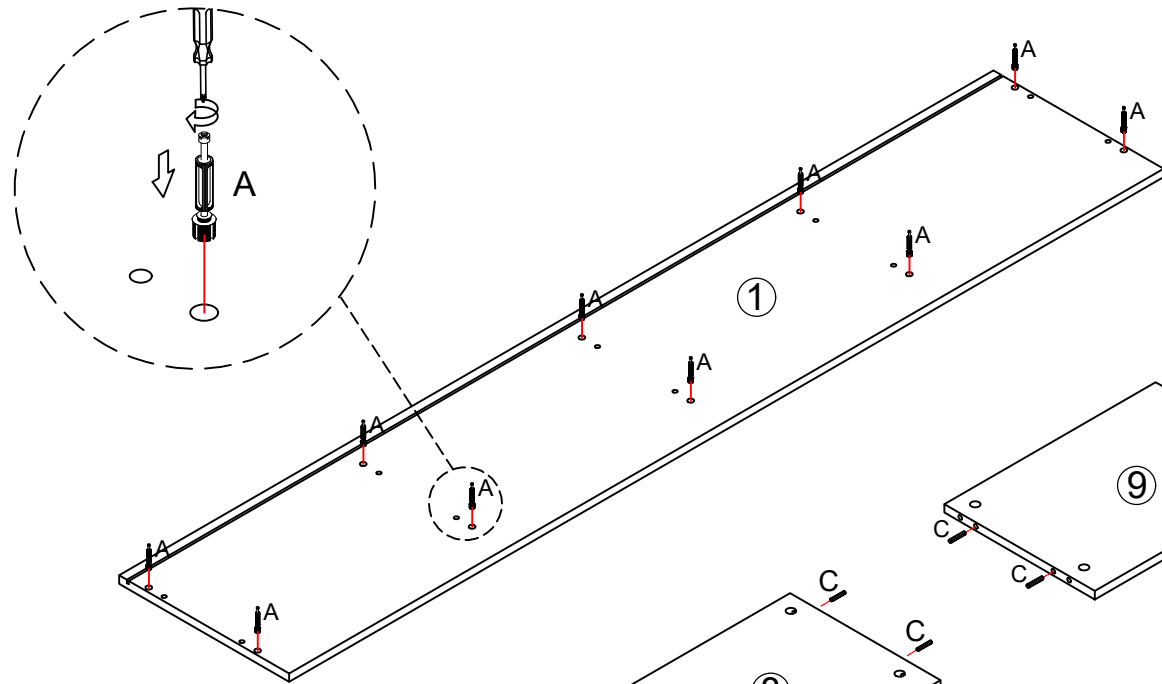

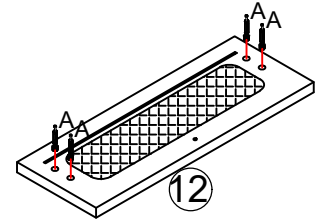
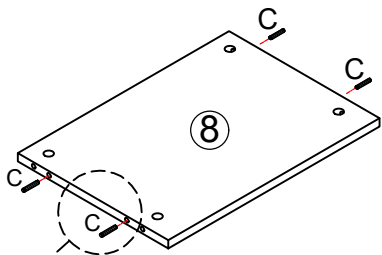
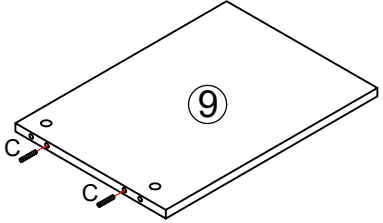
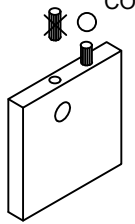

INCORRECT CORRECT

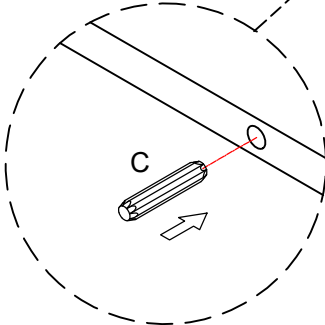

X2



	A*18
	C*6

put A on board ① ⑫
put C on board ⑧ ⑨

2

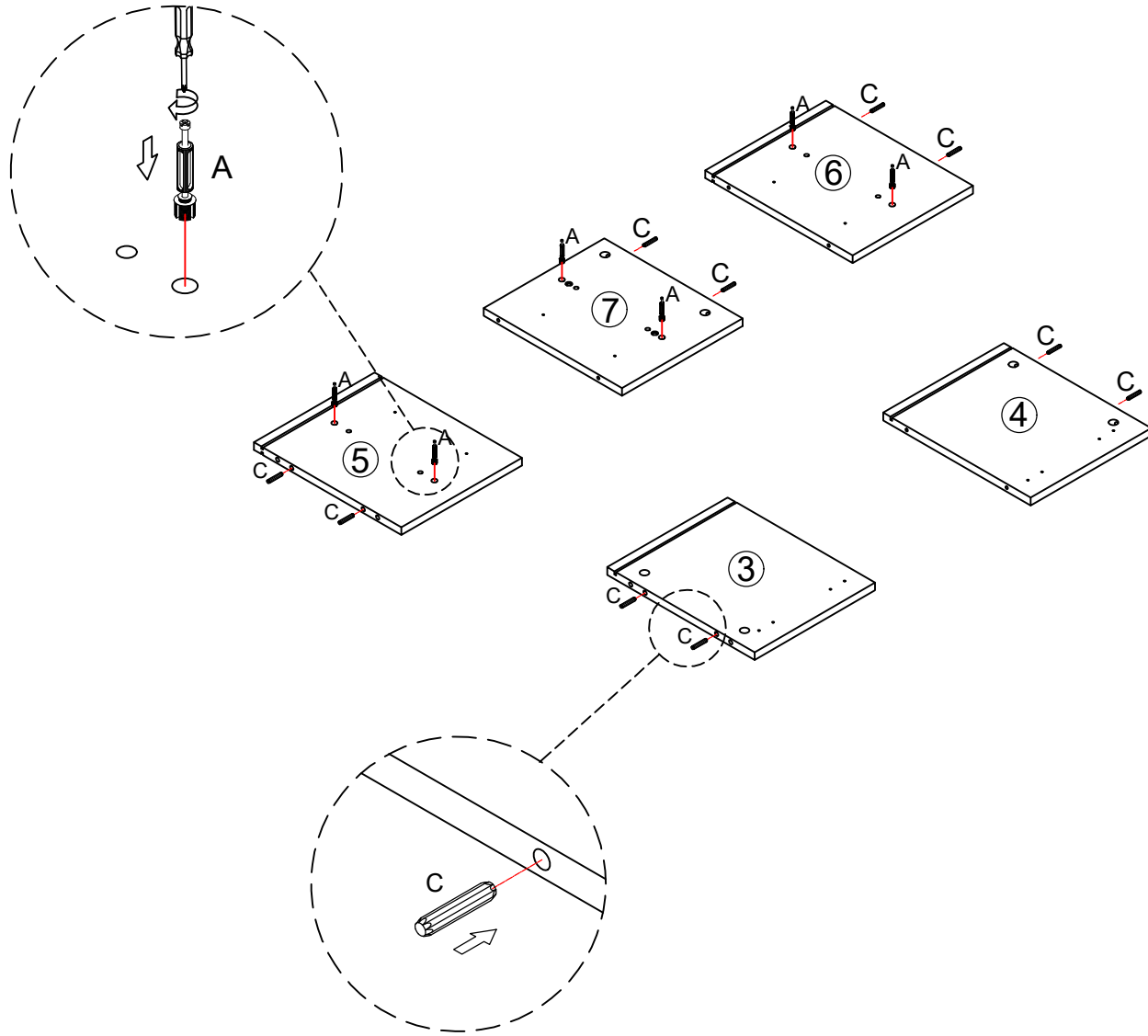

A*6



C*10

put A on board ⑤⑥⑦

put C on board ③④⑤⑥⑦

3

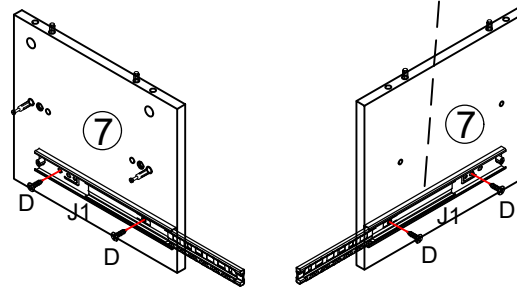
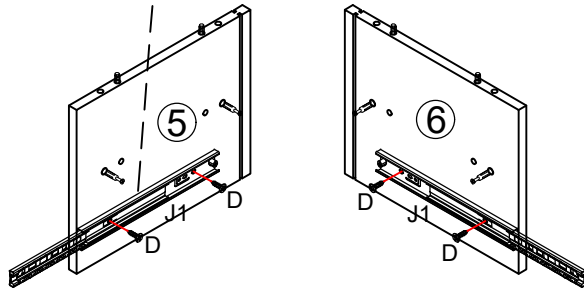
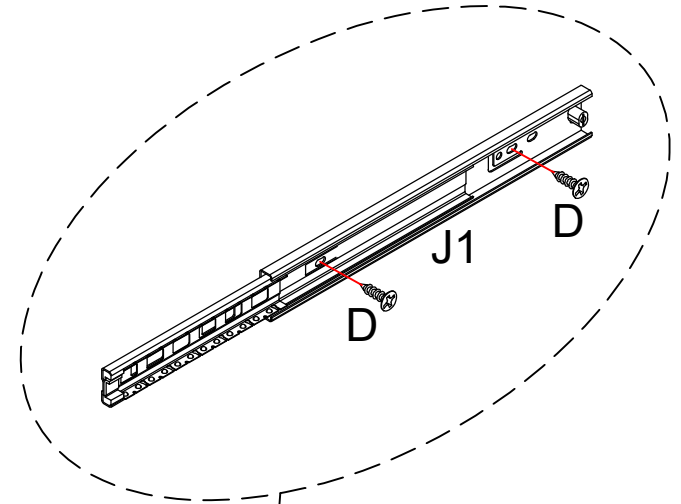
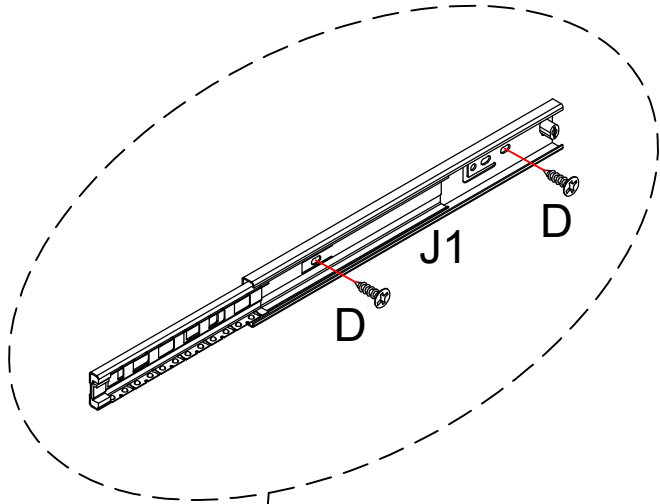

D*8



J1*2

4

Make sure the arrow on the screw align to the hole on the side.

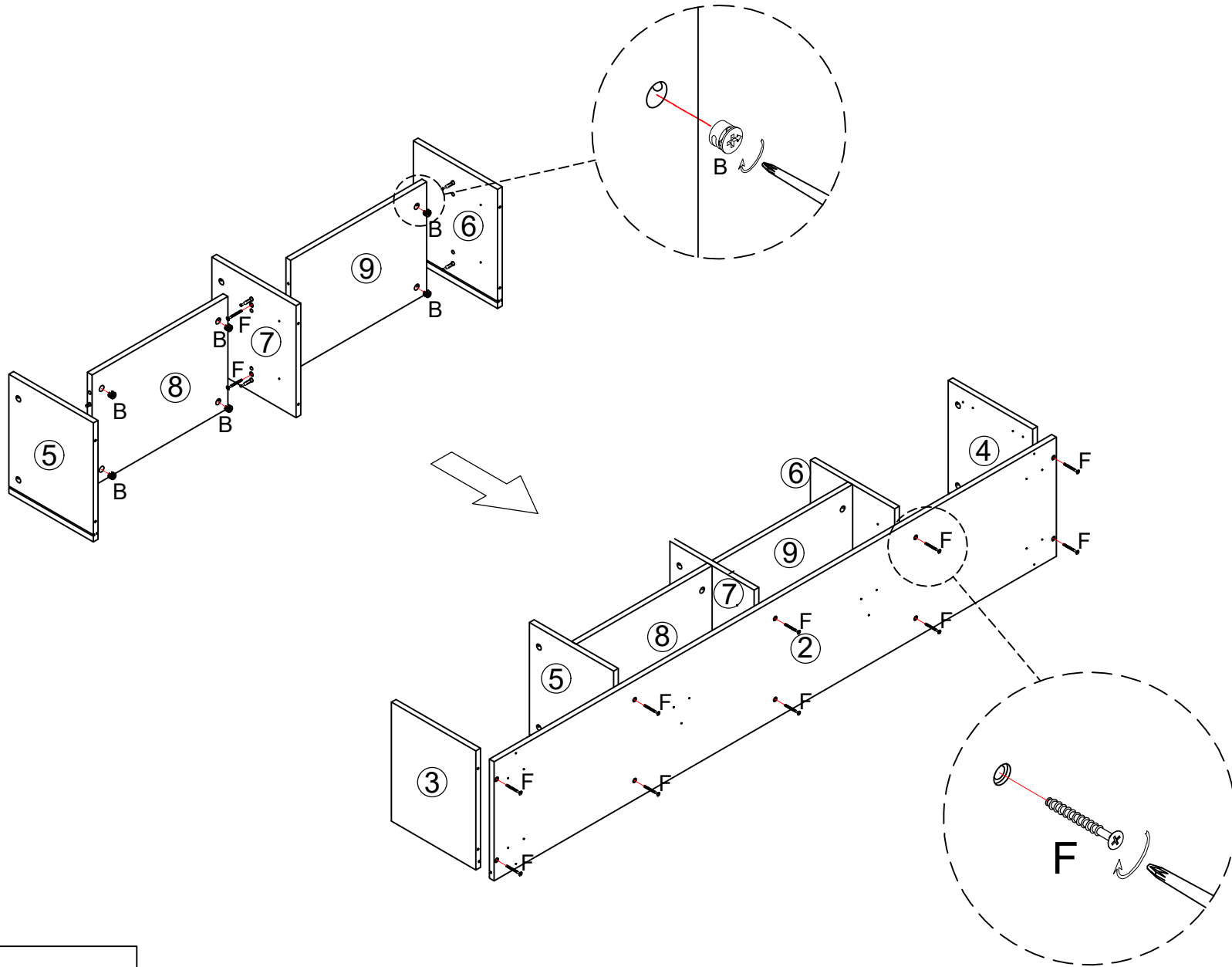

B*6





F*12

put B on board ⑧⑨

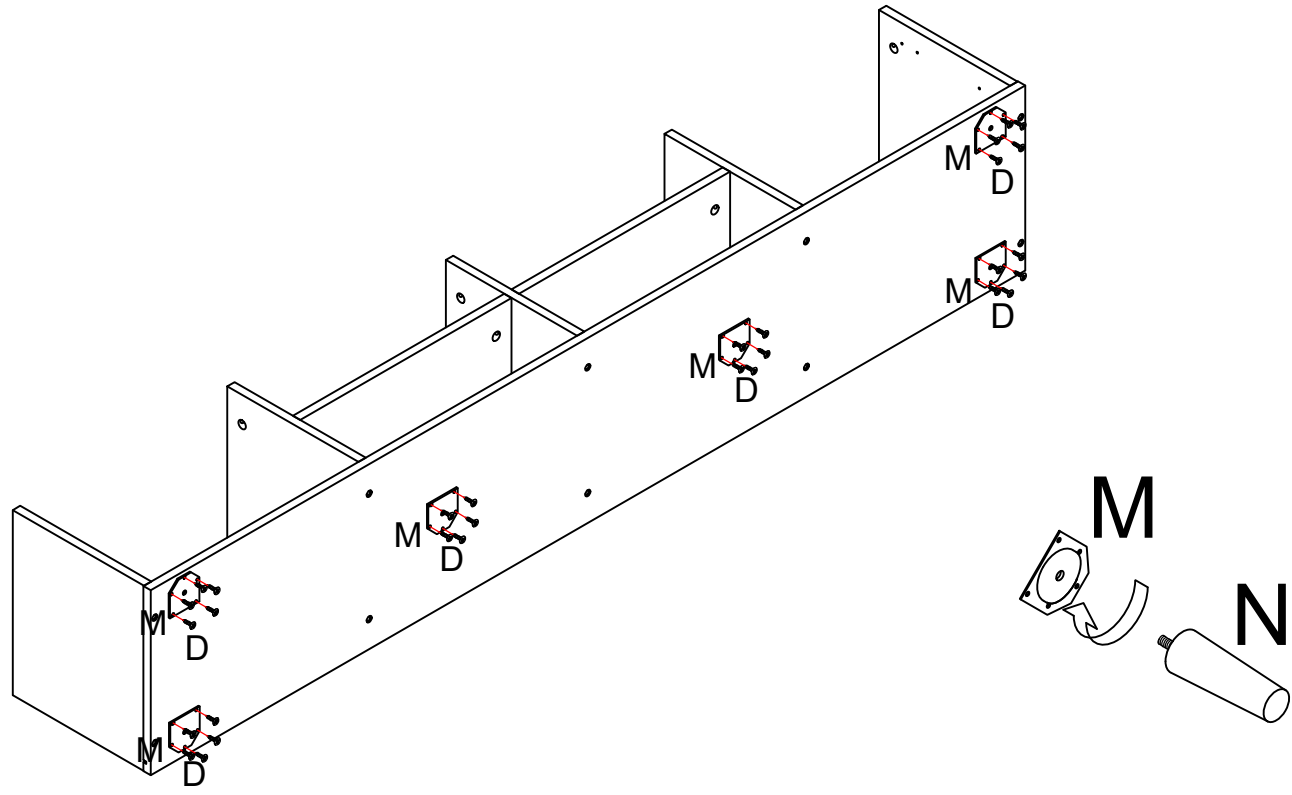
5



	D*30
	M*6
	N*6

6

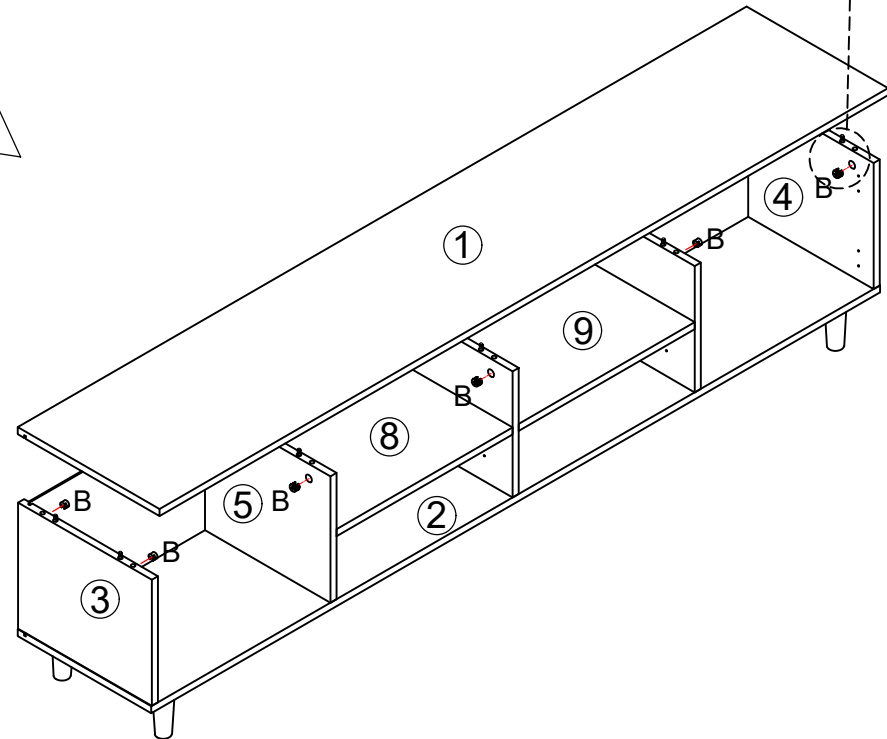
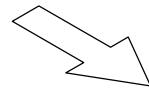
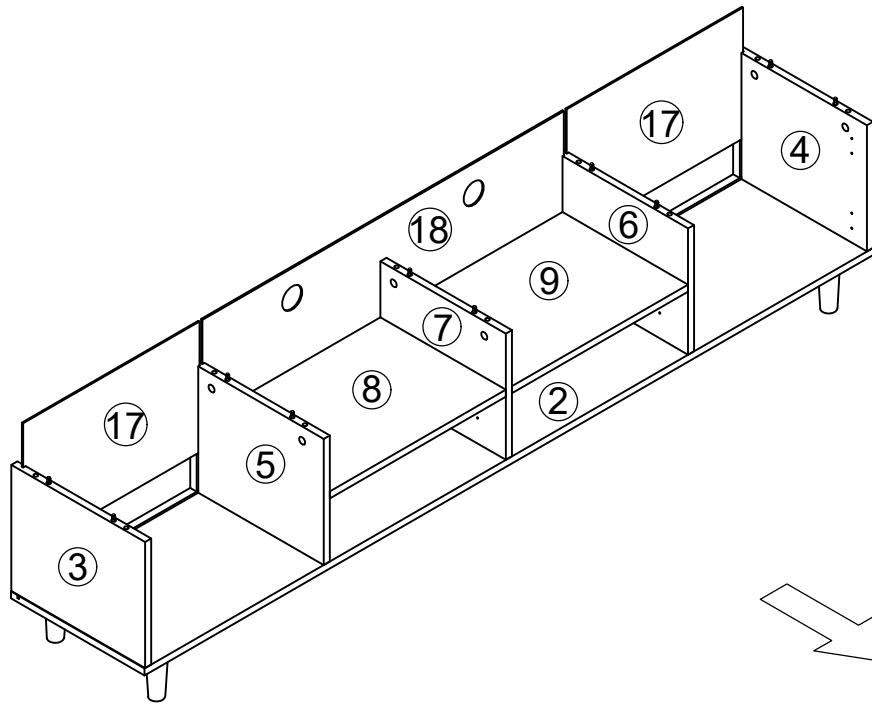

Make sure the arrow on the screw align to the hole on the side.

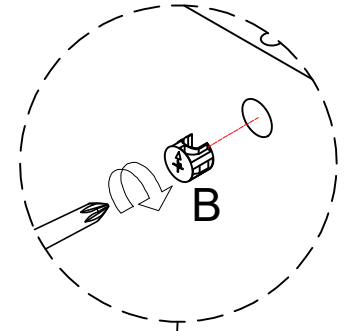



B*10

put B on board ③④⑤⑥⑦

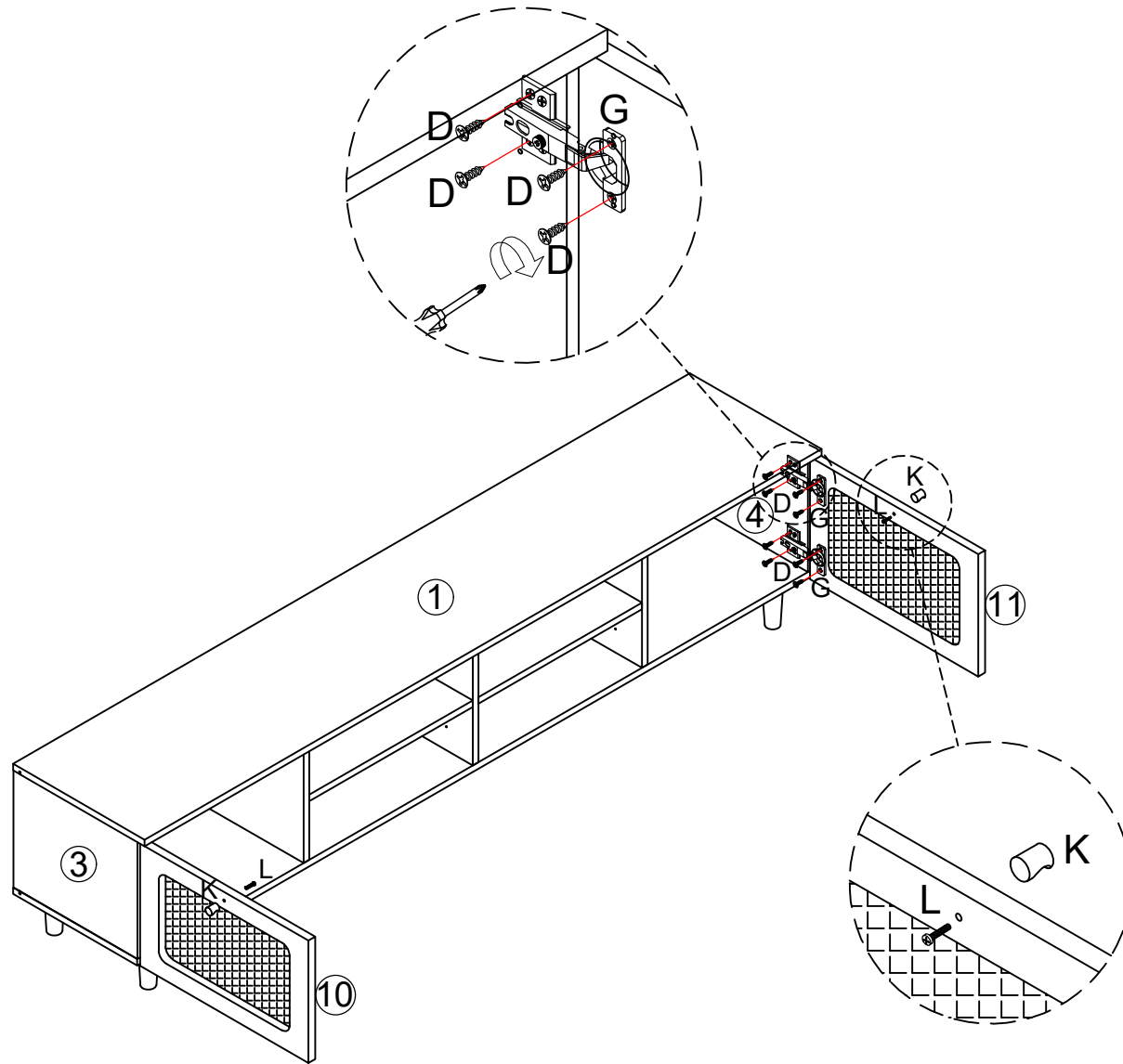
7

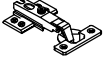





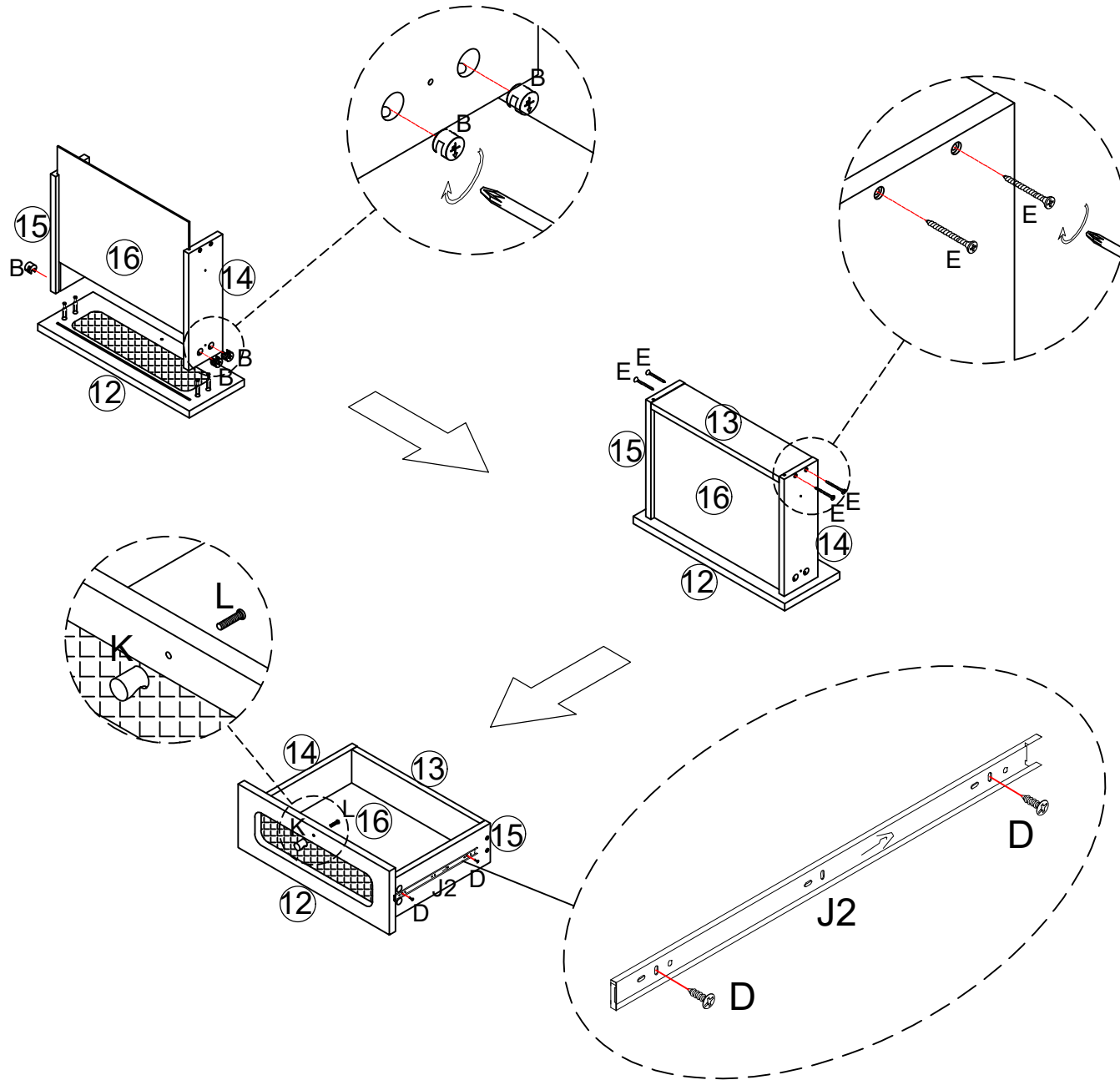

	D*24
	G*4
	K*2
	L*2

8

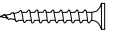
X2



	B*8
	D*8
	E*8
	J2*2
	K*2
	L*2

9

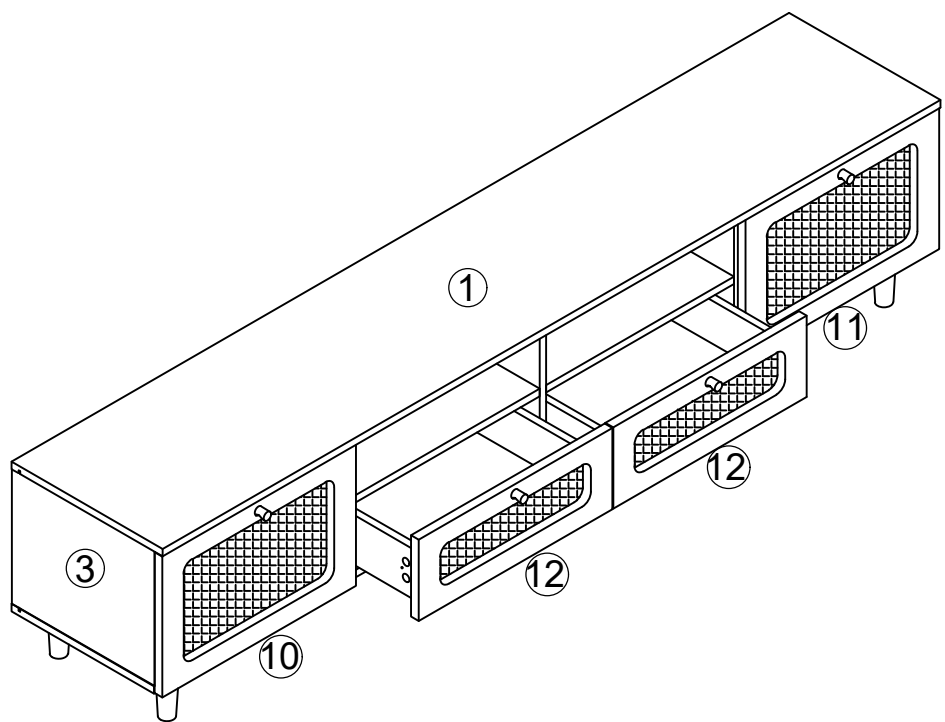

10

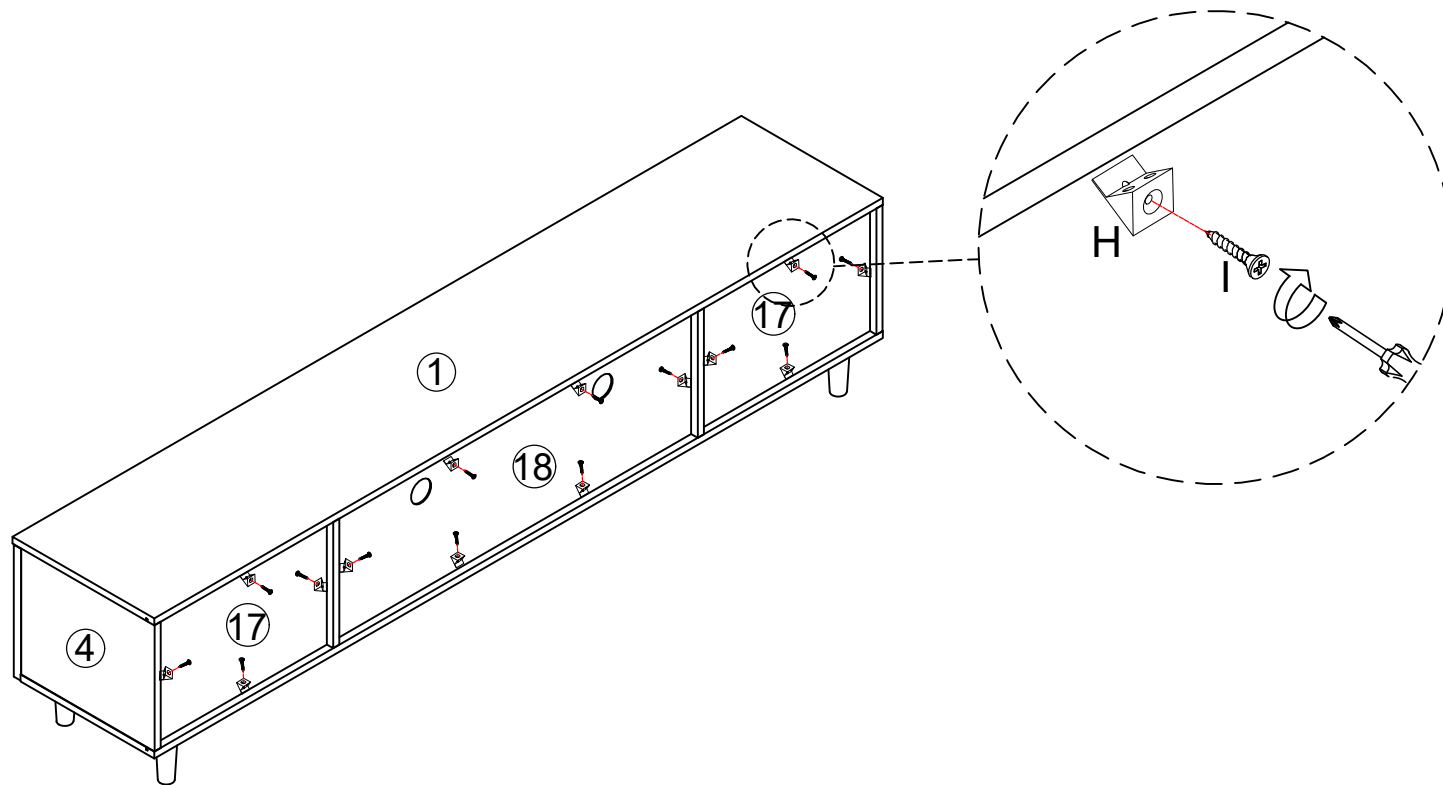

H*14



I*14

11

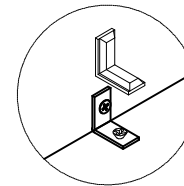
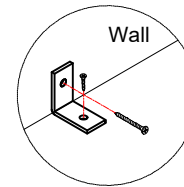
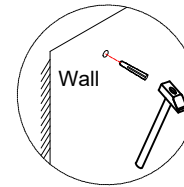
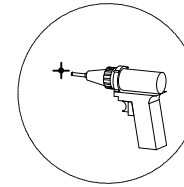
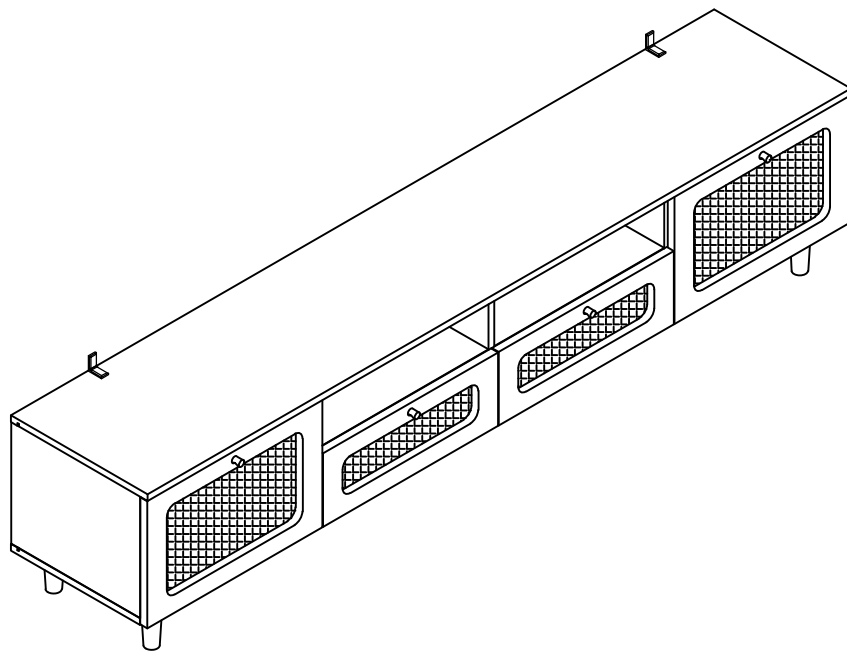

Please install tip-proof fitting.

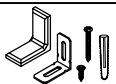

0*2

12

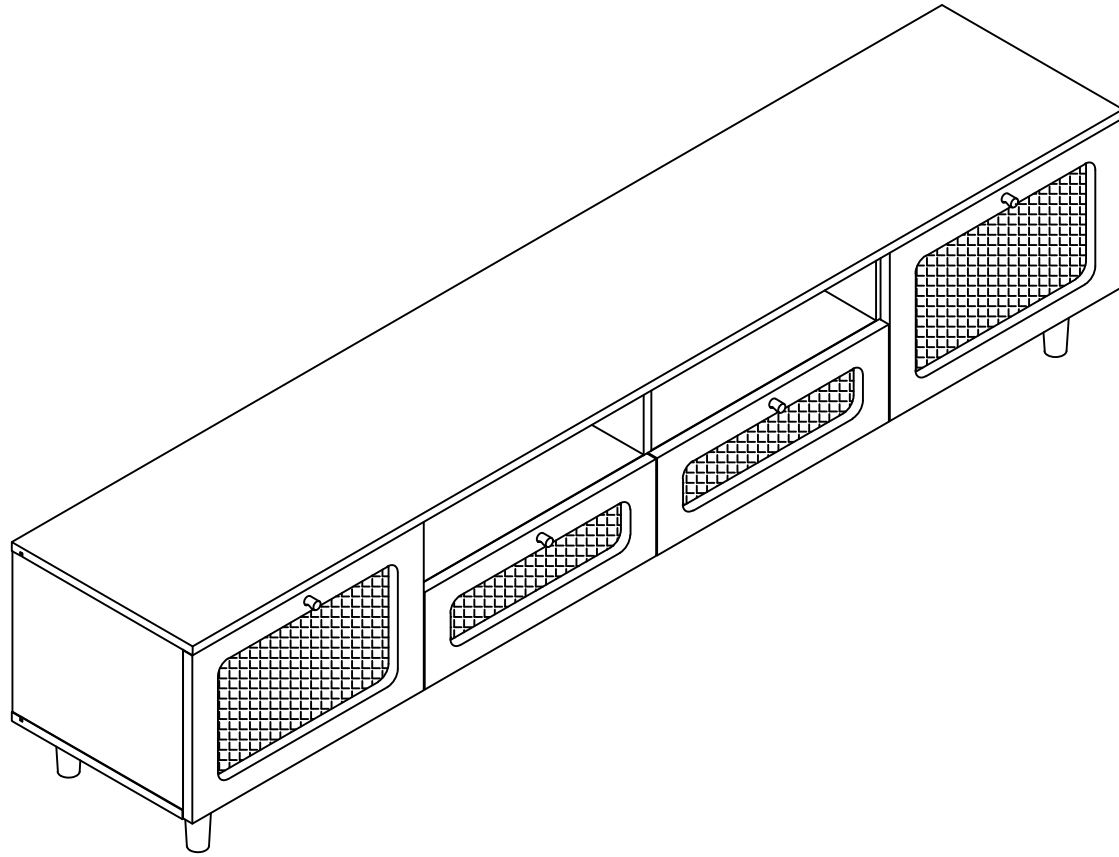

--END--