

# 35KV 有载分接开关

35KV On-load Tap Changer [OLTC]

## 安装使用说明书

Installation and Operating Instructions

V1.3

辽宁金立电力电器有限公司

LiaoNing Jinli Electric Power Electrical Appliance Co., Ltd.

欢迎您使用本公司的有载分接开关。

在使用您所购置的有载分接开关之前，请务必仔细阅读我公司的使用说明书。并妥善保管，以备使用中查阅。

谢谢！

You are welcome to use the on-load tap-changer produced by our company.

Before using the on-load tap-changer which you have bought, please be sure to read these instructions given by our company carefully and please look after the service manual carefully for you to refer to in the course of using the product.

Thanks!

## 一：总则

- 1.1 本说明书适用于额定电压为 35KV，额定通过电流 400A、300A、200A 以下系列的有载分接开关。（200A 及以下选用 200A）
- 1.2 额定电压 35KV 及以下系列有载分接开关，适用于交流 50HZ、一次侧线电压额定为 35KV，额定通过电流为 400A 及以下，配装油浸式变压器，是有载调压变压器的一个组成部分。本开关应选用本厂的相应配套的有载调压控制器，作为开关操作控制机构。本开关的基本作用是将开关的分接头连接至变压器高压线圈的一端分接头，在变压器带负荷的状态下，有载分接开关根据控制器发出的信号，自动地切换分接位置，以改变高低压线圈之间的匝数比，从而达到稳定或调节负荷中心的电压，提高电压质量，提高系统功率因数，减少无功消耗的有效措施之一。有载调压控制器，可用手动操作，也可以根据二次侧电压（额定值 400V）偏差信号，自动操作指令开关完成切换任务。
- 1.3 本开关的基本技术数据如下：  
 开关额定工作电流为 400A、300A、200A 及以下；  
 开关额定工作电压为 35KV；  
 开关最大分级电压为(相电压)600V；  
 开关最大调压级数为 9 级；（中性点 11 级）  
 分级调压幅值为 2.5%~5% ；
- 1.4 本有载分接开关适用于下列工作条件：  
 周围空气的最低温度为-25℃，最高温度为+40℃，  
 变压器油的最低温度为-25℃，最高温度为+100℃，且不能受潮，  
 开关安装场合与垂直面的倾斜度不超过 5 度。
- 1.5 本有载分接开关不适用于下列工作条件：  
 充满导电尘埃的介质环境；  
 腐蚀性气体或蒸汽的浓度足以破坏金属及绝缘介质的环境中；  
 有爆炸危险的场合。
- 1.6 有载分接开关型号说明：（ Explanation of Model ）

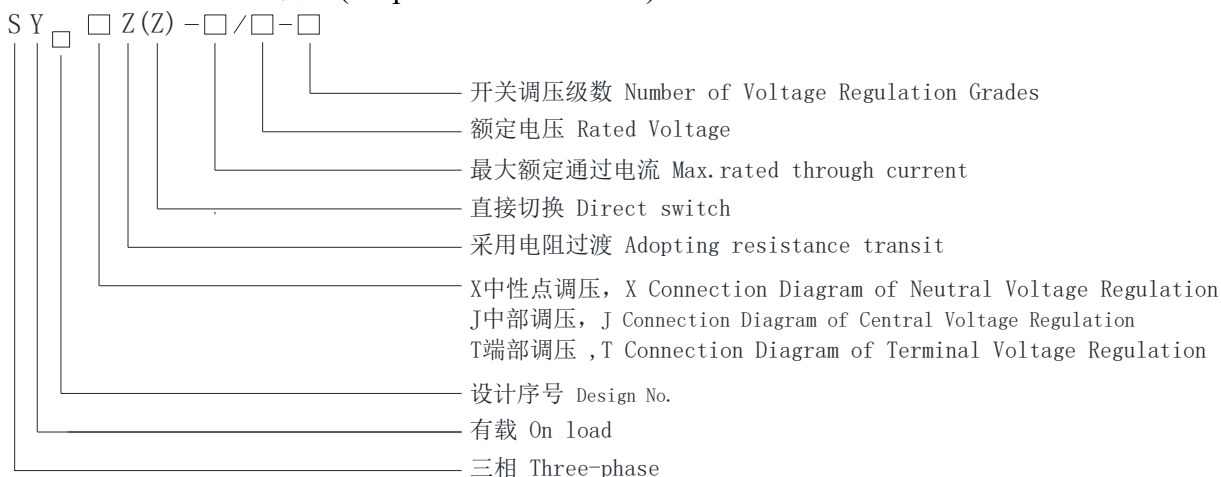

例如：SYJZZ 200/35-9 表示三相有载中部调压采用电阻式过渡电阻直接切换的有载开关，开关额定电流为200A，额定电压35KV，开关有9档分接。

For example: SYJZZ-200/35-9 shows: The load tap-changer of three-phase, central voltage regulation, 200A rated current, 35KV rated voltage, double directly resistive transition switching with 9 working positions,

## 1 . General Provisions

- 1.1 These instructions are suitable for a series of tap-changer with rated voltage of 35KV, the rated passing current of 400A, 300A, 200A and under one. (please choose 200A for equal to or under 200A) .
- 1.2 The tap-changer of the rated voltage of 35KV and under 35KV is suitable for fitting out the oil-immersed transformer of AC50HZ with primary side line voltage rated 35KV, rated passing current 400A and under 400A, it is one of the components of the on-load voltage-regulating transformer. This switch needs to select the relative matched on load voltage-regulating controller as the operation control device of the switch. The major function of this switch is to carry out the load tap-changing through the way to connect the tap-changing point of the switch to the tap-changing point of the high-tension coil of the transformer, under the load-up condition of transformer, on-load tap-changing the signal given by the switch according to the controller, automatically transfer the tap-changing positions to change the turn ration between the high-tension and low-tension coils, so as to stabilize or regulate the voltage of the load center, improve the voltage quality and the system power factor, and effectively reduce the reactive consumption. The on-load voltage-regulating controller can be operated manually, and can also automatically complete the switching task according to the deviation signal of the secondary side voltage (rated value 400V), automatic operation instructions.
- 1.3 The basic technical parameter of this switch is as follows:
  - The rated working current: 400A, 300A, 200A and under;
  - The rated working voltage: 35KV;
  - The maximum grading Voltage (phase voltage): 600V;
  - The Max. voltage-regulation grades: 9 positions ( neutral point is 11 positions)
  - The amplitude of grading voltage-regulation is 2.5%~5%.
- 1.4 This on-load tap-changer is suitable for the following working conditions:
  - The minimum ambient temperature is -25°C, the maximum ambient temperature is +40°C ,
  - The minimum temperature of the transformer oil is -25°C, the maximum temperature of the transformer oil is +100°C , at the same time can not be affect with damp.
  - The slop of the installation place of the switch and the vertical face shall not be over 5 degrees.
- 1.5 This on-load tap-changer is not suitable for the following working conditions:
  - in the environment where there is full of the medium of conductive dust;
  - in the environment where the density of the corrosive gas or steam is full enough to destroy the metal and the insulating medium;
  - in the place where there is a danger of explosion.

# SYX (J) ZZ 有载开关外形尺寸图:

## Outline Dimension Diagram of SYXZZ Load Tap changer:

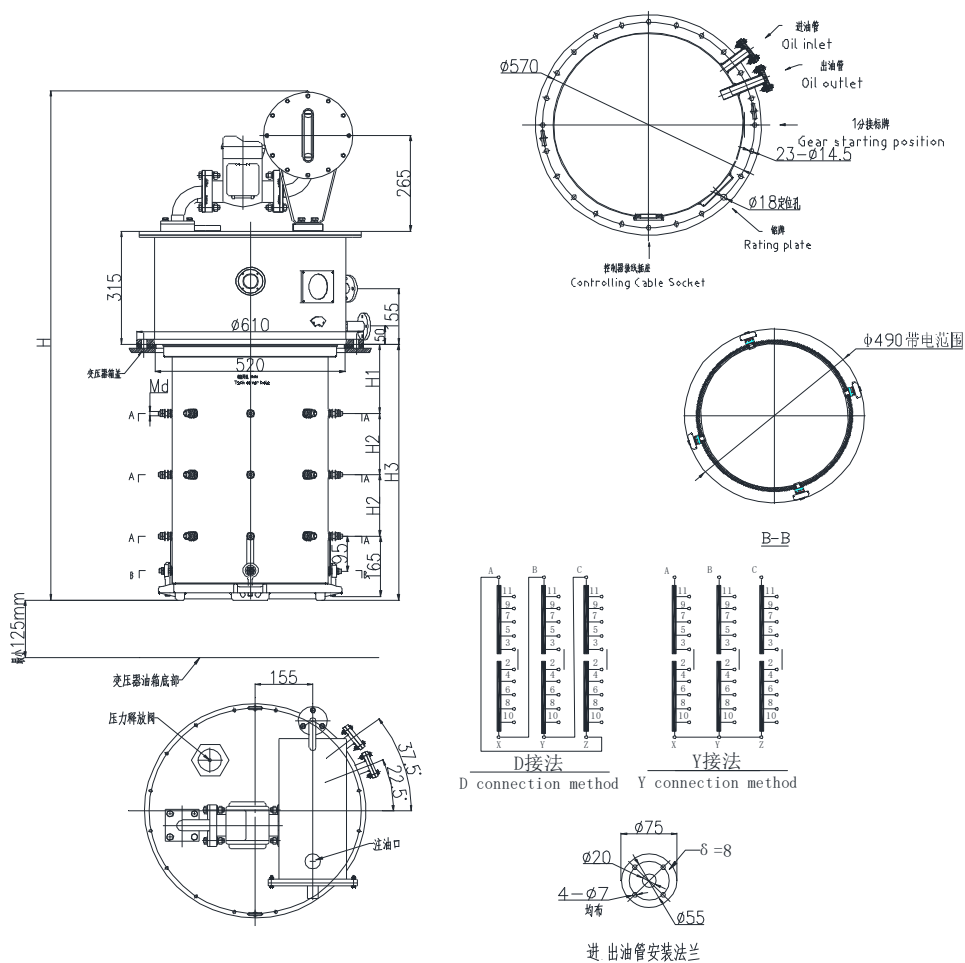

序号 Serial number	开关型号 Model No.	额定 电流 (A) Rated current	额定 电压 (v) Rated voltage	安装尺寸 (mm) Install dimension (mm)				
				H	H1	H2	H3	Md
1	SYXZZ 200/35-5~9	200	35	1400	190	170	715	M12
2	SYXZZ 300/35-5~9	300	35	1400	190	170	715	M14
3	SYXZZ 400/35-5~9	400	35	1610	220	235	910	M16
4	SYJZZ 200/35-5~9	200	35	1400	190	170	715	M12
5	SYJZZ 300/35-5~9	300	35	1400	190	170	715	M14
6	SYJZZ 400/35-5~9	400	35	1610	220	235	910	M16

注: 1.★具体以订货时我公司提供的《有载分接开关外形图》为准!!!

Note: 1.★ please refer to our provided 《on load tap changer outline drawing》 as standard when placing the order.

### SYTZZ 有载开关外形尺寸图:

### Outline Dimension Diagram of SYJZZ Load Tap changer:

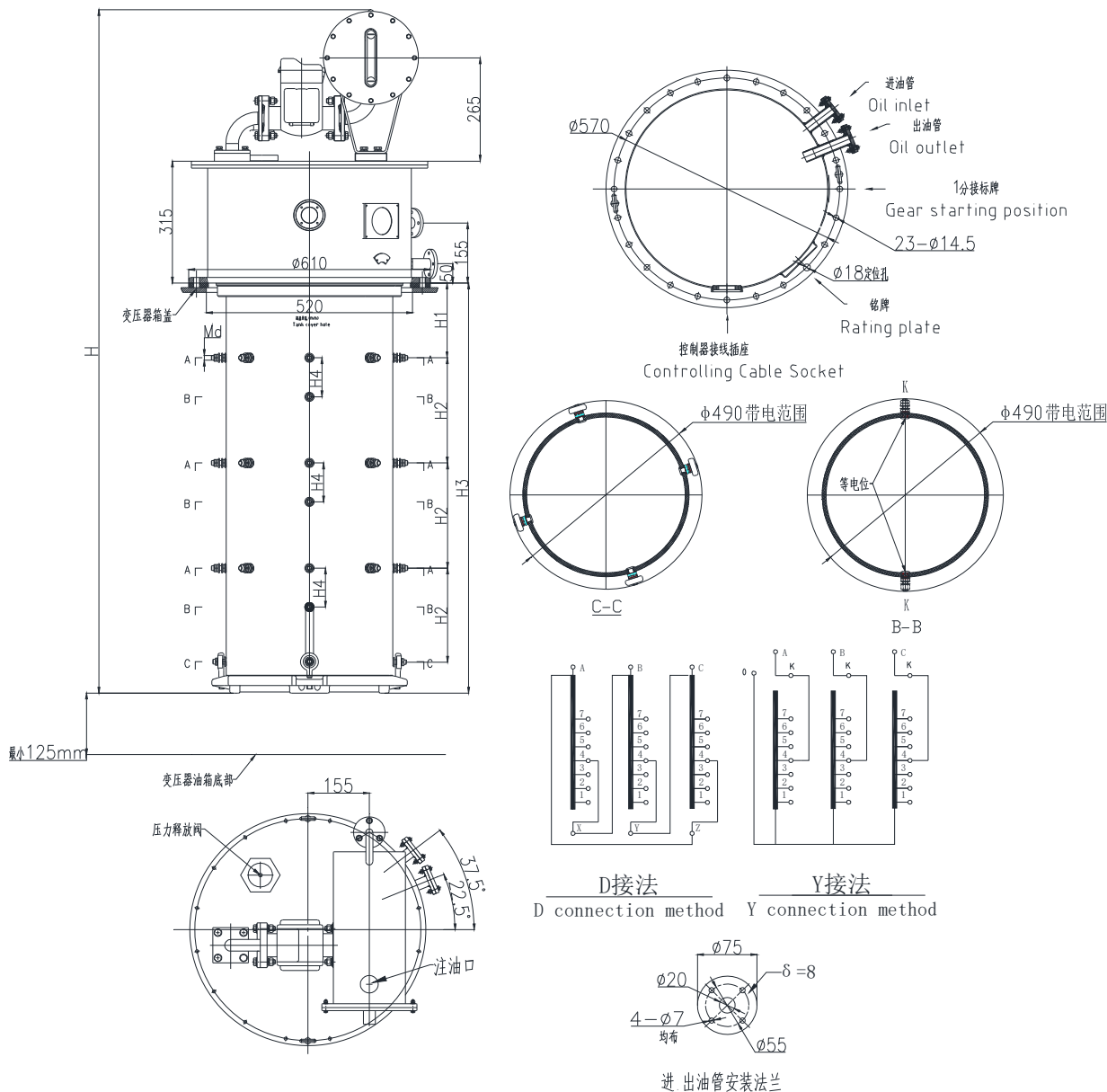

序号 Serial number	开关型号 Model No.	额定 电流 (A) Rated current	额定 电压 (v) Rated voltage	安装尺寸 (mm) Instal l dimension (mm)									
				$\phi D$	$\phi D1$	$\phi D2$	H	H1	H2	H3	H4	Md	n
1	SYTZZ 200/35-5~9	200	35	610	520	505	1700	190	270	1000	100	M12	23
2	SYTZZ 300/35-5~9	300	35	610	520	505	1700	190	270	1000	100	M14	23
3	SYTZZ 400/35-5~9	400	35	610	520	515	2025	220	370	1320	140	M16	23

注：1.★具体以订货时我公司提供的《有载分接开关外形图》为准!!!

Note: 1.★ please refer to our provided 《on load tap changer outline drawing》 as standard when placing the order.

### 三：有载开关电气、机械结构 The Electric Mechanical Structure of the On-load tap changer

#### 3.1 电气部分线连接图（以 9 级为例，其他档位开关详见控制器说明书）

Wire-connecting Drawing of Electric part (Taking Grade9 as an example, for the switch of other grades, please see the controller service manual)

#### 开关 21 芯航插编号(开关端): switch 21 cores socket numbers (switch port)

航插编号 No	1	2	3	4	5	6	7	8	9	10	17	18	19
功能 function	分接 1 1 TP	分接 2 2 TP	分接 3 3 TP	分接 4 4 TP	分接 5 5 TP	分接 6 6 TP	分接 7 7 TP	分接 8 8 TP	分接 9 9 TP	档位公共 端 Public Port	电机公共端 Motor Public P	电机降 Motor Dn	电机升 Motor Up
电缆线 编号 Cable No.	1	2	3	4	5	6	7	8	9	10	17	18	19

#### 开关 19 芯航插编号：（开关内部）switch 19 cores socket numbers (internal switch)

内连线航 插 Q24K19PJ	1	2	3	4	5	6	7	8	9	10	17	18	19
说明 Explanation	档位 1 P 1	档位 2 P 2	档位 3 P 3	档位 4 P 4	档位 5 P 5	档位 6 P 6	档位 7 P 7	档位 8 P 8	档位 9 P 9	档位公共 端 Public Port	电机公共端 Motor Public P	降 档 Up	升 档 Dn

注：启动电容在 18、19 之间。对应 10KV 电压等级开关（120W）电机为  $15\mu\text{F}$ ，对应 35KV 电压等级开关（180W）电机为  $20\mu\text{F}$ ，SYJZZ50/10-5LT 对应为  $3\mu\text{F}$ 。此电容已安装于本厂控制器内，若选用本厂控制器则无需额外加装此电容。

Note: The external starting capacitance is between 18 and 19. For 10KV voltage class switch (120W) motor is  $15\mu\text{F}$ . For 35KV voltage class switch (180W) motor is  $20\mu\text{F}$ .

### 3.2 有载调压电路原理图 On-load Voltage-regulation Circuit Principle Drawing

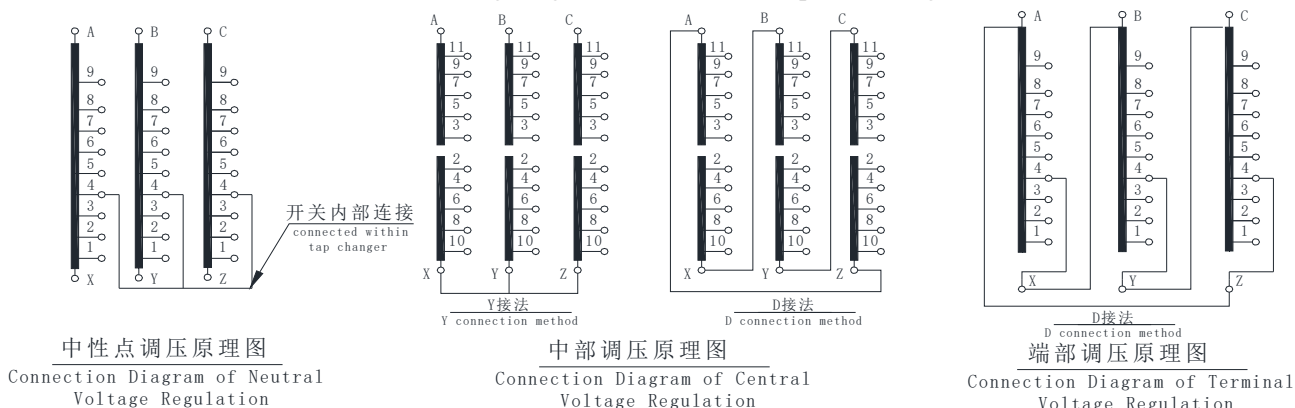

3.3 本开关是一种复合式的电阻过渡的埋入式有载分接开关，开关有隔离于变压器的单独油室利用变压器油作绝缘和灭弧介质，因此结构简单，体积较紧凑，也便于用户检修和换油。开关的安装法兰上面，即露出变压器油箱平面的那一部分，是机械传动部分，由单相电机带动二级蜗轮蜗杆做减速传动，由上隔板下面的弓形板推动主弹簧拉伸储能，利用弹簧“过死点”后释放的能量推动拨槽件由拨槽件推动槽轮，作传动一定角度的运动，完成开关的操作任务。在动触头支架的主动触头和辅助触头之间，由过渡电阻作切换过程中的限流作用；开关的动静触头上均镶嵌铜钨合金，使开关的电气寿命足以能完成所规定的技术指标。

This switch is a kind of imbedded on-load tap-changer of composite resistance transition. The switch has its separate oil container which is isolated from the transformer, and uses the transformer oil as the medium of insulation and arc suppression; therefore, its construction is simple, the volume is compact, its is also convenient for the user to check and repair it and replace the oil. The upper part of the mounting flange of the switch, namely the part that appears above the plane surface of the oil tank of the transformer, it is the mechanical driving part, with the one-phase motor driving the second grade worm-and-gear doing gearing down, with the bow plate under the upper baffle plate driving the main spring to stretch for energy storage, using the energy released by the “over-die-point” of the spring to drive the slot-dialing part and the slot-dialing part to drive the slot-wheel to transfer the movement with a certain angle, so that it completes the operation task of the switch. Between the main movable contact on the supporting shelf of the movable contact and the auxiliary contact, the transition resistor completes the current-limiting function in the course of switching, there is copper-tungalloy inlaid respectively on the movable and stationary contacts, which makes the service life of the switch full enough to reach the required technical index.

### 3.4 开关的主要性能指标:

触头的接触电阻不大于  $500 \mu \Omega$  ;

开关各部位能承担下列规定的工频耐压试验，历时一分钟，不发生绝缘体击穿，闪络或局部发热等绝缘强度明显下降的现象

The index of the main Properties of the switch:

The contacting resistance of the contact is not over  $500 \mu \Omega$  ;

All the parts of the switch can undertake the following stipulated power frequency withstand voltage test for one minute without breakdown of insulated body, over flash, or partial heat and other phenomena of the insulating strength obviously falling.



额定参数 Rating parameter (以 300A 为例 sample as 300A )

型号 Type		SYXZZ—300 /35—□	SYJZZ—300/35—□	SYTZZ—300/35—□	
最大额定通过电流 A Max. Rated Passing Current A		300			
相数 Number of phases		3			
连接方式 Connecting Method		Y (中性点 Neutral-point)	Y 或 D(跨接 Bridging)	D	
短路试验电流 Short-circuit Test current KA	热稳定 3 秒 Thermal stability 3seconds	4			
	动稳定峰值 Dynamic stability peak value	10			
级电压 (以每相计算) Stage Voltage (Calculated according to each phase)		600			
最大工作位置数 Max. number of working places		9	9	9	
绝缘水平 KV Insulation level KV	对地 To earth	电压等级 Voltage Grade	35		
		设备最高电压 Max. Voltage of the equipment	40.5		
		工频试验电压 Power-frequency Testing Voltage	85		
		冲击试验电压 (1.2/50ms) Impulse Test Voltage	200		
	内 部 Inside	相间 Between Phases	工频试验电压 Power-frequency Testing Voltage	35	85
			冲击试验电压 (1.2/50ms) Impulse Test Voltage	75	200
		最大最小 分接间 Max. Min Tapping space	工频试验电压 Power-frequency Testing Voltage	45	
			冲击试验电压 (1.2/50ms) Impulse Test Voltage	105	
		级间 Between Grades	工频试验电压 Power-frequency Testing Voltage	10	
			冲击试验电压 (1.2/50ms) Impulse Test Voltage	30	
	机械寿命 Machinery's service life		不低于 50 万次 No less than 500000 times		
	电气寿命 Electric equipment service life		不低于 5 万次 No less than 50000 times		
密封试验 Seal Test	工作压力 Work pressure	$3 \times 10^4$ Pa			
	试验压力 Test Pressure	$6 \times 10^4$ Pa 24 小时不渗漏 No leaking for $6 \times 10^4$ Pa 24 hours			
气体继电器 Gas Relay		QJ <sub>4</sub> —25 整定油速 1.0m/s $\pm$ 10% QJ <sub>4</sub> —25 permanent oil speed 1.0m/s $\pm$ 10%			
重量 (不含油) Weight (not including oil)		150kg			
干燥 Drying		气象干燥最高 110℃ 真空干燥最高 110℃ Weather drying Max. 110℃ Vacuum Drying Max. 110℃			
配用自动控制器 Provided Automatic Controller		JLK—103			

开关导电部分对变压器油的温升不超过 20℃；

The temperature rising of the transformer oil caused by the conducting part of the switch is not over 20℃；

## 四：开关的安装

- 4.1 开关和变压器油箱平面的连接依靠焊在油箱上的螺栓与开关安装法兰连接固定，螺栓的长度至少为 36 毫米，开关的安装法兰和变压器油箱之间有安装垫圈（耐油橡胶）作为密封材料；
- 4.2 开关在安装前应进行干燥处理，干燥时间为 5~6 小时，温度为  $100\pm 5^{\circ}\text{C}$ ，最好在真空下进行，干燥后的交流耐压标准，开关载流体对地绝缘应满足工频耐压 72KV 一分钟的要求（试验时，开关应浸在绝缘强度 35KV 变压器油中），干燥后必须检查紧固件是否松动，若发现松动时，必须重新紧固及止退防松；
- 4.3 开关与变压器一次侧调压线圈的接线方法，即将开关分接头序号最高位接至高压线圈匝数最少的一个位置，而将序号最低位接至高压线圈匝数最多的一个分接位置，其他的，以此类推。开关分接头序号的排列是按顺时针方向排列的；
- 4.4 开关使用前体内应注入油质良好的变压器油，油位应达到油标红线刻划的油平面，要求油质的绝缘强度在 40KV 以上；
- 4.5 开关随变压器出厂及用户使用时，务必将航插防护罩安装好，防止进水，使开关电气部分受潮。
- 4.6 开关安装后，开关最底面与开关油箱需要保证 125mm 以上间隙!!!**

### IV. Installation of Switch

- 4.1 The connection of the switch with the plane-face of the oil tank of the transformer depends on the bolt welded on the oil tank of the transformer to connect the mounting flange for fixation, the bolt is 36mm long at least. There is a mounting spacer ring (oil-resistant rubber) used as the seal material between the mounting flange of the switch and the oil tank of the transformer;
- 4.2 Before installed, the switch should be received the drying treatment, the drying time is 2-3 hours, temperature is  $100\pm 5^{\circ}\text{C}$ , it is better be carried in vacuum, the AC withstand voltage standard after drawing, the insulation of the load fluid to earth should satisfy the requirement of power frequency with stand voltage 35KV for one minute (when testing, the switch should be immersed in the oil of the transformer with the insulation strength of 35KV); After drying, the fastener must be checked for looseness. If it is found to be loose, the fastener must be tightened again.
- 4.3 The wiring method of the switch with the voltage-regulating coil of the primary side of the transformer, namely, connect the highest position of the order number of the tap-changing point of switch to a position having the least turn number of the high-tension coil, in the meanwhile, connect the lowest position of the order number of tap-changing position to the most turn number of the high-tension coil, for others, and so forth. The order number of the tap-changing points of the switch is arranged according to the clockwise direction;
- 4.4 Before the switch is used, should inject the high-quality transformer oil into it, the oil level should reach the oil plane surface marked with the red line of the oil gauge, the insulating strength of the oil quality is required to reach over 40KV.
- 4.5 When the switch leaving the factory and being used, the user must install the protective shelter for the air socket well to prevent the electric part of the switch from wetting coming of water-entering.
- 4.6 After the tap changer is installed, the gap between the bottom surface of the tap changer and tap changer oil tank should be more than 125mm!!**

## 五：开关的使用

本开关配装有载调压控制器，进行自动和手动操作。

开关在投入运行前应作以下检查

- 5.1 开关投入运行前应进行 10 个循环操作，以检查开关的机械动作是否灵活，限位是否可靠，本开关上的限位螺钉（300A 以下及 9 档以下）是作为控制器电器连锁失灵后才会使用的机械限位，正常情况下不使用；
- 5.2 应测量变压器高压侧线圈（连接上本开关后）在各分接位置时的直流电阻与出厂数据相比较，以判断是否正常；
- 5.3 检查油质是否良好。

## V. Use of Switch

This switch is equipped with the on-load voltage-regulating controller, which can operate automatically or manually

Before starting to work, the switch should receive the following inspections:

- 5.1 Before it put into operation, the switch should perform 10 circles of operation in order to check to see if the mechanical movement of the switch is smooth, if the position-limit reliable or not, the position-limit screw on this switch (Under 300A and under Grade 9) is the mechanical limit position used when the inter lock of the electrical appliances of the controller having not worked, it is not used in normal condition;
- 5.2 Measure the DC resistance of the high-tension side line of the transformer (having connected to this switch) at each tap-changing position and compare it with the ex-factory data to judge is it is all right or not;
- 5.3 Inspect the oil quality to see if it is qualified or not.

## 六：开关运行及检修 Operation and Maintenance

在变压器运行前必须检查开关及附件的连接密封是否良好（吸湿器使用见其使用说明）  
各种连线是否接触良好

Before the transformer starting to operate, have to inspect the connecting seal of the switch and the auxiliary parts to see if it is good or not (for the usage of the moisture absorber, refer to its service manual) and if all the connecting wires are connected well or not.

在变压器投运前必须检查开关头部、气体继电器和连接管道的密封。定期记录开关的操作次数并保存。

本系列开关机构全部浸在油中，平时不需要经常维护，运行 2000 次后，从排油管中抽取开关底部的油样，进行试验。取样时先放去 2 公斤，以保证油样的真实性。油样含炭粒并逐渐发黑是正常现象，如油的耐压低于 35kv，则应更换或过滤。加入净油的耐压应大于 40kv。换油一般可结合检修，亦可在带电的情况下进行，只要从排油管排出污油，同时向进油管注入净油即可，如在排油管及进油管之间接入滤油机，亦可循环滤油。

Before the transformer starts to operate, must examine the seals of the head of the switch, the gas relay and the connecting pipe-line; regularly record the operating times of the switch and preserve the data.

The organs of this series of switches are fully oil-drowned so usually do not need everyday maintenance; When it has operated for 2000 times, should extract the oil-sample of the bottom of the switch out of the oil outlet pipe to carry out experiment. When taking the sample, firstly should let off 2 kg so as to ensure the validity of the oil-sample. It is normal phenomenon that the oil-sample contains carbon granules gradually becoming black. If the oil's voltage withstand capability is lower than 35KV, the oil should be replaced or filtered. The voltage withstand capability of the injected new clean oil should be more than 40KV. The oil-changing commonly combines with the examination and repairing, it is also can be carried out under the condition of on load, if only the dirty oil runs out of the oil outlet pipe at the same time the clean oil is entering the oil inlet pipe. If connecting an oil-filtering machine between the oil outlet pipe and the oil inlet pipe, the circulating oil-filtering can be carried out.

※ 但我们建议为了保证开关的可靠运行，必须定期检修。

※However, we think you have to make the regular examination and repair of the switch in order to ensure it can keep the reliable operation.

- 6.1 开关投入运行第一年，宜半年检修一次，以后可根据检修结果及操作次数适当延长，以油质为准。一般切换 2000 次后检查一次，检查时取出插入式芯子的步骤如下：

In the first year after the switch is put into operation, it should be checked once half a year. After that, it can be extended appropriately according to the maintenance results and operation times, depending on the oil quality. Generally, after 2000 times of switching, it is checked once. During the inspection, the steps for removing the insert core are as follows:

- a) 排油管排油，使油面降至油箱外壳的下法兰附近；
- b) 拆去顶盖及顶盖上的附件；
- c) 拆去箱盖内出线端子上的控制回路接线；
- d) 拆去芯子定位螺栓上的螺母；

- e) 拉出芯子, 为了避免弹簧触头的撞击和磨损, 先拉高约 60 mm 左右, 在转一个角度 (约  $10^\circ$ ), 使弹簧触头和绝缘筒上相应的静触头相互错开, 再向上拔, 取出芯子。
- a) the oil outlet pipe drains oil to make the oil level drop to the vicinity of the lower flange of the oil tank shell;
- b) Remove the top cover and the accessories
- c) Remove the wiring of the control loop on the outlet terminals inside the box cover;
- d) Remove the nut on the insert core positioning bolt;
- e) pull out insert type core, in order to avoid spring contact impact and wear, it is appropriate to divide two steps out to pull out about 60 mm first and then in turn an Angle (about  $10^\circ$ ), so that the spring contact and insulation cylinder corresponding static contact can be staggered for each other, then pull up, take out the core.

6.2 安装过程与上述相反。The procedure of installation is opposite to the above-mentioned  
用油洗净芯子各部分及开关油箱内壁, 还应检查下列各部分情况:

- a) 拔去拉簧桩头, 检查开关转动是否灵活, 动静触头间滑动是否可靠, 动作是否正常;
- b) 检查快速机构传动的情况, 拉力弹簧有无损伤, 拨盘及槽轮的圆弧面有无打毛, 蜗轮减速机构是否灵活;
- c) 检查槽轮上平面与拨盘之间, 间隙是否两边保持相等距;
- d) 检查开关铜钨合金触头的烧损情况, 烧毛处可用细砂布轻轻砂平, 以减少动静触头之间的摩擦阻力 (在砂主触头时, 要注意把触头移到空档处)。当动静触头烧损超过一定限度时应予以调换。由于各部分烧损速度区别很大可采用相互调换方式延长使用寿命。但在调整过程应注意校正触头的水平位置, 使其不大于 0.1 毫米;
- e) 检查过渡电阻有无过热现象, 测量直流电阻值与出厂数据比较判断是否正常;
- f) 检查所有螺母、销子有无松动;
- g) 检查绝缘筒壁上触头有无松动, 放电痕迹。如筒壁破损严重, 应予以更换。

检查完毕后, 将电动机电源接通, 切换十个循环, 注意开关有无慢动作现象。最后按前所述进行投运前的检查试验。

Clean all the parts of the core and the internal wall of the oil-tank of the switch with the oil; it is also necessary to examine the conditions of all the following parts:

- a) pull and remove the pile-head of the tension spring, check if the switch operates freely or not, if the sliding between the movable contact and the static contact is reliable or not, if the movement is all right or not;
- b) Check the transmission of the speedy organs to see if there is damage with the tension spring, if there is burr on the face of the circular-arc of dial an the slot-wheel, if the worm gear speed reducing device is flexible or not;
- c) Check if the two sides of the gap between the plane on the slot-wheel and the dial keep equal distance;
- d) Check the burned degree of the copper-tungsten alloy contact, where there is burned burr can be polished slightly with fine emery cloth in order to reduce the frictional resistance between the movable and static contacts (When polish the main contact, take care to move it to the neutral position). The movable and static contactors should be replaced if they are burned beyond the limit. As the burned degrees are different from each other, you can adopt the method of exchanging them to prolong the service life. However, in the course of regulation should take care to correct the horizontal position of the contactors to make it not more than 0.1 mm;
- e) Check if the transition resistor has the phenomenon of over heating, measure the direct current resistance and compare it with the ex-factory data to judge if it is right or not;
- f) Check all the nuts and bolts to see if there is looseness or not;
- g) Check the contactor on the wall of the insulation barrel to see if there is looseness or discharge trace. The wall of the barrel should be changed if it is seriously broken.

Having completed the checks, you can turn on the motor and let it switch 10 circles and take care to see if the tap-changer has the phenomenon of slow motion. At last, carry out the check and test, prior to beginning the operation according to the above-mentioned.

- ※1. 在检修开关时，必须确保开关和变压器已经断电，并且已可靠接地
- ※2. 开关主体暴露于干燥空气中，不应超过必要的时间（最长 10 小时）
- ※3. 在检查过程中，要小心不要让任何零件落入开关主体内，要随时核对零件数

- ※ 1. When repairing the switch, must be sure that the electric supply of the switch and the transformer have been cut off, and have been reliably put to earth.
- ※ 2. It is not allowed for the main body of the switch to expose in the dry air for too long time (The longest time shall not be more than 10 hours)
- ※ 3. In the course of checking, should take care not to let any parts fall into the main body of the switch, and should check the number of the parts at any time.

6.3 用户对于运行和维修的情况，请作好记录，如有特殊情况，请随时与我厂联系，以互相交流运行和维修经验；

The user should keep record about the operation and repairing of the switch, if there is anything special, please contact our factory at anytime so that we can exchange the experience about the operation and maintenance of the switch.

#### 6.4 使用注意事项 Precautions for Using

6.4.1. 本开关平均每天分接变换次数最多为30次。

6.4.2. 本开关运行2000次~2500次必须更换新变压器油；但如果频繁操作将会使变压器油加速变质，当变压器油击穿电压值低于30KV时，应停止自动电压控制器的使用，当变压器油击穿电压值低于25KV时，应停止分接变换操作，并要及时处理。更换或处理后的变压器油耐压值应 $\geq 40KV$ 。

6.4.3. 当系统中因倒闸操作或其他原因，可能造成电压大幅度波动时，应将有关变压器分接开关的自动控制器暂停使用，待操作完毕恢复正常后，再恢复自动控制。

6.4.4. 本开关更换变压器油两次或运行5000次后，必须对开关进行检修，操作方法详见使用说明书。

6.4.5. 本开关的安装投运与运行维修标准，应参照《有载开关运行维修导则 DL/T 574-2010》执行。

6.4.1 The average number of tap changer switching per day is up to 30.

6.4.2 New transformer oil must be replaced when this switch is operated for 2000-2500 times; However, frequent operation will accelerate the deterioration of transformer oil. When the breakdown voltage value of transformer oil is lower than 30KV, the use of automatic voltage controller should be stopped. When the breakdown voltage value of transformer oil is lower than 25KV, switch transformation operation should be stopped and timely treatment should be conducted. The voltage withstand value of transformer oil after replacement or treatment shall be  $\geq 40KV$ .

6.4.3 When the voltage fluctuation may be caused by switching operation or other reasons in the system, the automatic controller of the transformer switch should be suspended in use, and the automatic control shall be resumed after the operation is completed and restored to normal.

6.4.4 After the transformer oil is changed twice or run for 5000 times, the switch must be repaired. Please refer to the operation instruction for details.

6.4.5 The installation, operation, operation and maintenance standards of this switch shall refer to 《On-Load Tap Changer Operation and Maintenance Guidelines of DL/T 574-2010》 to perform.

6.5 开关附件详见装箱单

For the accessories of the switch please refer to packing list.

## 七：开关的常见故障和排除方法 Common troubles of the switch and Eliminating Method

### 7.1 接通电源开关，控制器不工作，指示灯不亮：

检查控制器供电是否为 220V AC，电源保险丝是否熔断；

Turn on the power switch, the controller does not work, and the indicating lamp does not light:

Check the power supply of the controller to see if it is 220V AC, if the power fuse has blown or not;

### 7.2 电源指示灯亮，但档位无显示，控制器不工作：

#### a) 检查控制器与开关之间的电缆是否脱落；

#### b) 检查控制器是否有问题：方法是卸下电缆插头，用导线一端搭在公用端“10”，另一端分别连接“1”—“9”，若显示相应档位，则控制器无故障；另外，用导线将“10”与“2”连接，按动“上升”或“下降”按钮，若听到继电器吸合声，说明控制器无故障，应进一步检查分接开关；

#### c) 检查开关内航插是否松动，航插两端相对应数码的连线是否导通；

The power indicating lamp lights, but the grade-position does not display, the controller does not work:

#### a) Check the cable between the controller and the switch to see if it has fallen off or not;

#### b) Check the controller to see if there is any problem with it or not. The method is as follows:

Remove the cable plug, let one end of the conductor connect with common end “10”, the other end respectively connect with “1” — “9”, if it shows the relative grade-position, that is to say the controller is all right. Then let a conductor connect “10” with “2”, push the “rising” or “falling” button, if hearing the sound of the relay pick-up it means that the controller is all right, should make a further inspection of the tap-changer;

#### c) Check the air socket in the switch to see if it is loose or not, if the connecting wire of the corresponding digits of both ends of the air socket is conducting or not;

### 7.3 档位显示正常，按“上升”或“下降”按钮开关不动作：

#### a) 卸下开关侧 21 针航空插头，用导线将“10”与“2”连通，万用表拨至 250VAC 档，两表笔分别插入“18”、“17”孔，按动“下降”按钮，万用表应显示 220V（若表笔插入“19”、“17”孔，则按动“上升”按钮）；

#### b) 用万用表 $R \times 1 \Omega$ 档测量 21 针航空插座的“10”与“2”之间是否接触不良，正常时应为“0 $\Omega$ ”；

#### c) 用万用表 $R \times 10 \Omega$ 档测量 19 针航空插座的“14”与“17”、“15”与“17”之间，电阻均为 51 $\Omega$ 左右为正常，若偏差太大，甚至短路或开路，说明开关内电机损坏；

Grade-position displays normally, push “rising” or “falling” button, the switch does not work:

#### a) remove switch side 21-needle air plug, connect “10” with “2” using a conductor. Dial the universal meter pens respectively meter to the stage-position of 250VAC, put the two meter pens respectively into Hole “18” and Hole “17”, push the “falling” button, the universal meter should display “220V” (if the meter pens are respectively put into Hole “19” and Hole “17”, should push the “rising” button);

#### b) use stage-position $R \times 1 \Omega$ of the universal meter to check the 21 needle air socket to see if the contacting between “10” and “2” is all right or not, when it is normal, the value shall be “0 $\Omega$ ”;

#### c) use stage-position $R \times 10 \Omega$ of the universal meter to measure 19 needle air socket resistance between “14” and “17”, “15” and “17”. If their resistance values are equal to about 51 $\Omega$ , it means “normal”; if the deviation is too great, even short circuit or open circuit, that is to say the electric machine in the switch is broken;

### 7.4 连续报警，若工作于自动状态时，开关连续升至最高档无信号电压：

检查信号电压是否正常或信号线是否脱落；

Continuously alarming, if working in the automatic condition, the switch continuously rises to the highest stage-position without signal voltage:

Check the signal voltage to see if it is normal or the signal wire has fallen off or not;

### 7.5 档位显示混乱或任何档位都显示“8”：

航插进水或电缆短路，需更换。

The stage-position displays in confusion or any stage-position displays “8”:

Water entered the air socket or the cable is short circuit, it should be replaced.

## 八：定货须知 Rules for Ordering Goods

用户定货时，需提供下列数据：

  配套变压器的容量；

  变压器线圈连接组别；

  一次侧和二次侧额定电压；

  分级调压幅值；

  开关和控制器连接电缆线长度，一般供货长度为 15 米；

  如用户需单独供应开关控制器，则需特殊说明。

When ordering goods, you need to provide the following data:

The capacity of the transformer to equip;

Transformer coil connection group

The rated voltage of primary side and secondary side;

The amplitude of step voltage regulation;

The length of the cable connecting the switch and the controller, the general length for supply is 15m;

If the user needs to order the controller of the switch separately, should give a special explanation.

如有订货及特殊要求请与我公司技术部联系！

*If you want to order the goods and have special requirement, please contact the Technical Department of our company!*

**辽宁金立电力电器有限公司**

LiaoNing Jinli Electric Power Electrical Appliance Co., Ltd.

地址 Add: 辽宁省丹东市振安区同兴镇: Tongxing Zhenan District Dandong City Liaoning Province

电话 Tel: 0415-6135555 (Telephone exchange) 6134555 传真 Fax: 0415-6131000