

WSL 系列无励磁分接开关

WSL Series Non-excitative Tap-changer

安 装 使 用 说 明 书

Installation and Operation Instructions

辽宁金立电力电器有限公司

Liaoning Jinli Electric Power Electrical Appliance Co., Ltd.

欢迎您使用本公司的无励磁分接开关。

在使用您所购置的无励磁分接开关之前，请务必仔细阅读我公司的使用说明书。并妥善保管，以备使用中查阅。

谢谢！

You are welcome to use the non-excitative tap-changer produced by our company.

Before using the non-excitative tap-changer, which you have bought, please be sure to read these instructions given by our company carefully for you to refer to in course of using the product.

Thanks !

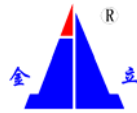

1. 用途及适用范围 Use and Applicable Range

本公司生产的 WSL 系列无励磁分接开关,有卧式和立式、钟罩式、箱顶式四种型式,适用于频率为 50HZ、60HZ, 额定电压 10KV、35KV、66KV、110 KV 额定电流 125~1000A 单相、三相、油浸式变压器。其调压方式有 I 端部、II 中部 (单桥跨接)、III 中性点、IV Y-△转换、V 串并联、VI 正反调压; 可直接固定在变压器箱盖上,在无励磁状态下分接调换。

该产品在原设计的基础上广泛吸取了许多用户的改进性意见,经过本厂技术部门的确定,做了许多改进设计。

WSL series non-excitative tan-changer produced by this company has four types: horizontal-type, vertical-type, bell-type and box-top type. They are suitable for the one-phase and three-phase oil-immersed transformers with the frequency of 50HZ, 60HZ, the rated voltage of 10KV, 35KV, 66KV, the rated I current of 125~1000A; Voltage regulation mode: I Connection diagram of terminal voltage regulation, II single-bridge connection, III for neutral point, IV Y-△ conversion, V series-parallel connection, VI positive-negative regulating. they can be directly fixed on the box-cover of the transformer to carry out tap-changing under the non-excitative condition.

This product has been improved greatly in its design on the base of the original design, widely absorbing the improving suggestions from many users and through the decision of the technical department of this factory.

2. 产品型号说明:

W S L □ □ / □ - □ × □ □

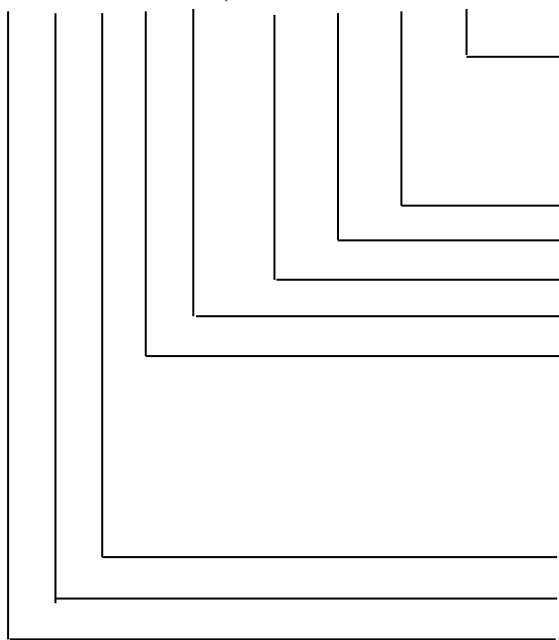

- W: 卧式安装 horizontal installation
- L: 立式安装 vertical installation
- Z: 钟罩式安装 bell type installation
- D: 箱顶式安装 box-top type installation
- 分接位置数 Number of tap-changing positions
- 分接头数 number of tap-changing contacts
- 额定电压 Rated Voltage
- 额定电流 Rated Current
- I 端部调压 End Part Voltage Regulation
- II 中部调压 Central Part Voltage Regulation
- III 中性点调压 Neutral Point Voltage Regulation
- IV Y-△转换 Y-△ Transfer
- V series-parallel connection
- VI positive-negative regulating
- 笼型 Cage-like Type
- 三相 Three-phase (D 单相 Single-phase)
- 无励磁分接开关 on-excitative Tap-changer

3. 主要技术参数 Major Technical Parameter

注: 在绝缘强度 35KV 变压器油中

Note: in the transformer oil at the insulating strength of 35KV contact

额定电压 Rated Voltage KV	接线方式 Wiring Method	工频耐受电压 1min Power frequency withstand Voltage 1min			触头接触电阻 μΩ Contact contacting resistance μΩ
		对地 To earth	相间 Interphase	触头间 Between Contacts	
10	Y	42	10	10	≤350 μΩ
	△	42	42	18	≤350 μΩ
35	Y	95	35	12	≤350 μΩ
	△	95	95	30	≤350 μΩ
66	Y	140	140	45	≤350 μΩ
110		△	230	230	55

4. 安装 Installation

4.1 开关接线原理图 Wiring Principle Drawing of Switch

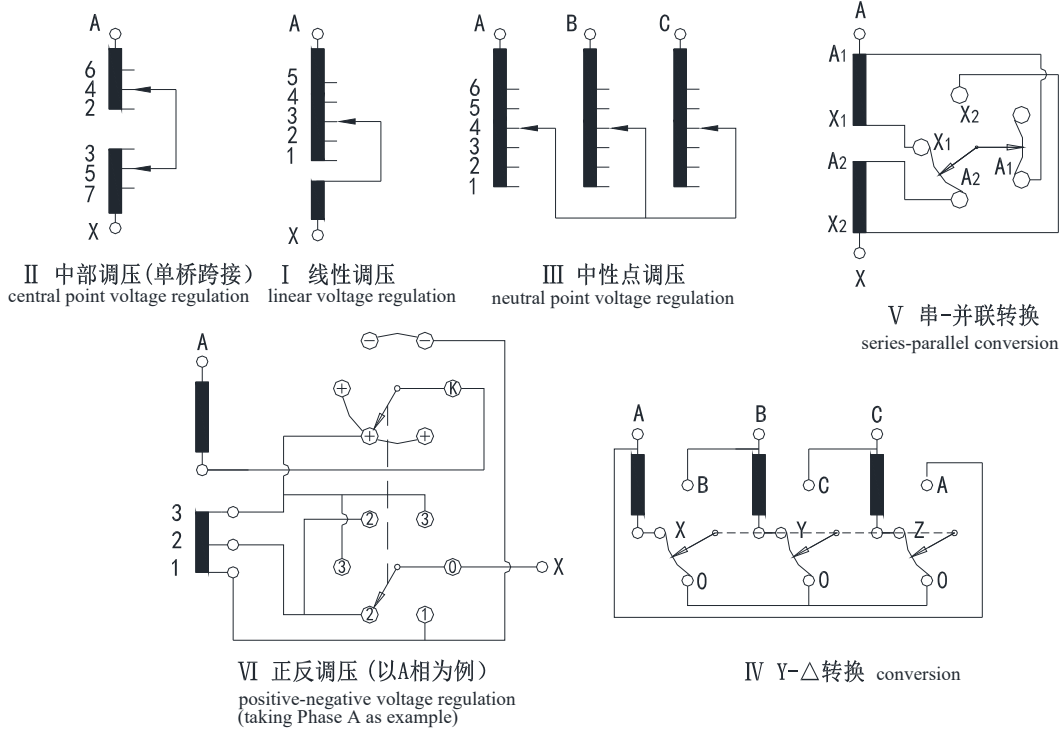

4.2 开关外形结构 Outline Structure of Switch

4.2.1 卧式开关外形图 Outline Drawing of Horizontal-type Switch

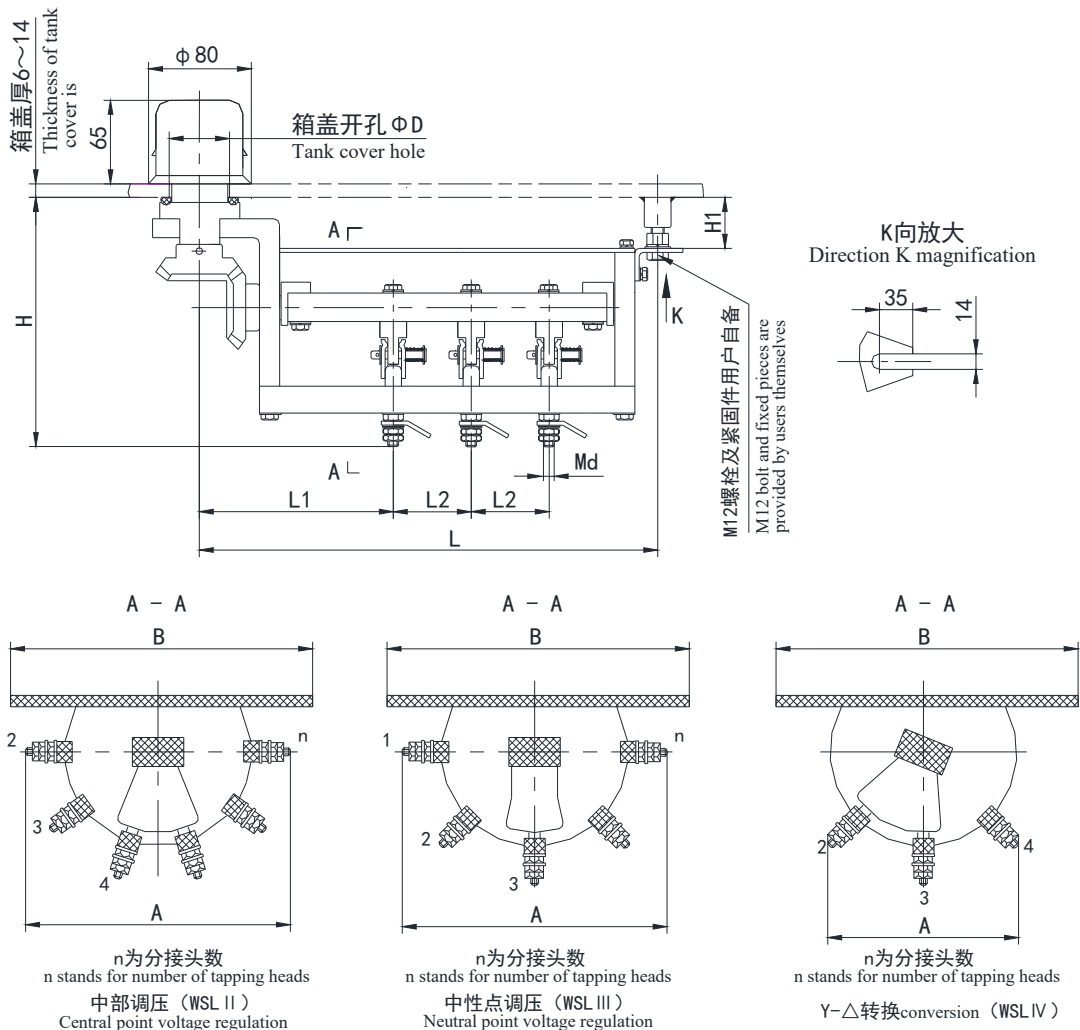

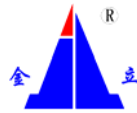

上图中 In the figure above: 10~35kv 开关 tap change H1=37m m ; 60~66kv 开关 tap change H1=20m m
 额定电流 Rated Current 125A: Md=M8; 250A:Md=M10; 400A:Md=M16; 630A:Md=M18

4.2.2 卧式开关安装尺寸 Mounting Dimension of Horizontal Switch

开关型号 Switch Type	额定电流 Rated Current (A)	额定电压 Rated Voltage (KV)	箱盖开孔ΦD Tank cover hold	安 装 尺 寸 Mounting Dimension					
				L	H	B	A	L1	L2
WSL II 250/10-3×2 W	250	10	φ 43	385	180	220	175	135	70
WSL II 125/10-4×3 W	125			365	165	220	192	130	65
WSL II 150~250/10-4×3 W	150~250			385	170	220	200	135	70
WSL II 400/10-4×3 W	400			500	195	280	250	167.5	95
WSL II 600~630/10-4×3 W	600~630			515	200	300	268	165	105
WSL II 125/10-6×5 W	125			365	182	230	212	130	65
WSL II 150~250/10-6×5 W	150~250			385	190	255	220	135	70
WSL II 300、400/10-6×5 W	300、400			500	212	300	272	167.5	95
WSL II 600、630/10-6×5 W	600、630			515	220	320	288	165	105
WSL II 125/10-7×6 W	125			365	200	260	235	130	65
WSL II 250/10-7×6 W	200、250			385	205	280	240	135	70
WSL II 125/10-8×7 W	125			365	200	260	242	130	65
WSL II 200、250/10-8×7 W	200、250			385	205	280	250	135	70
WSL II 300、400/10-8×7 W	300、400			500	245	360	332	167.5	95
WSL II 125~250/35-4×3 W	125~250			35	φ 43	641	170	250	200
WSL II 400/35-4×3 W	400	661	195			300	252	205	138
WSL II 125~250/35-6×5 W	125~250	641	200			290	250	203	130
WSL II 400/35-6×5 W	400	661	225			340	292	205	138
WSL II 125~250/35-7×6 W	125~250	641	230			360	296	203	130
WSL II 125~250/35-8×7 W	125~250	641	230	360	310	203	130		
WSL II 125~250/60~66-4×3 W	125~250	60~66	φ 43	1020	330	400	295	321.5	200
WSL II 125~250/60~66-6×5 W	125~250			1020	330	450	350	321.5	200
WSL III 125/10-6×6 W	125	10	φ 43	365	200	260	242	130	65
WSL III 200、250/10-5×5 W	200、250			385	205	280	250	135	70
WSL III 400/10-5×5 W	400			500	220	300	276	167.5	95
WSL III 125/10-7×7 W	125			365	200	260	242	130	65
WSL III 200、250/10-7×7 W	200、250			385	205	280	250	135	70
WSL III 125~250/35-7×7 W	125~250	35	φ 43	641	205	290	250	203	130
WSL II 125/35-10×9 W	125			641	255	400	352	203	130
WSL II 250/35-10×9 W	250			641	260	400	360	203	130
WSL III 250/35-9×9 W	250	10	φ 61	641	240	360	320	203	130
WSL II 125/10-10×9 W	125			365	222	340	312	130	65
WSL II 250/10-10×9 W	250			385	226	340	320	135	70
WSL III 250/10-9×9 W	250			385	236	340	312	135	70
WSL II 250/10-11×10 W	250			385	230	340	312	135	70
WSL II 250/10-12×11 W	250			385	260	380	360	135	70
WSL II 250/35-14×13 W	250			35	641	290	470	420	203

4.2.3 立式开关外形图 Outline Drawing of Vertical-type Switch

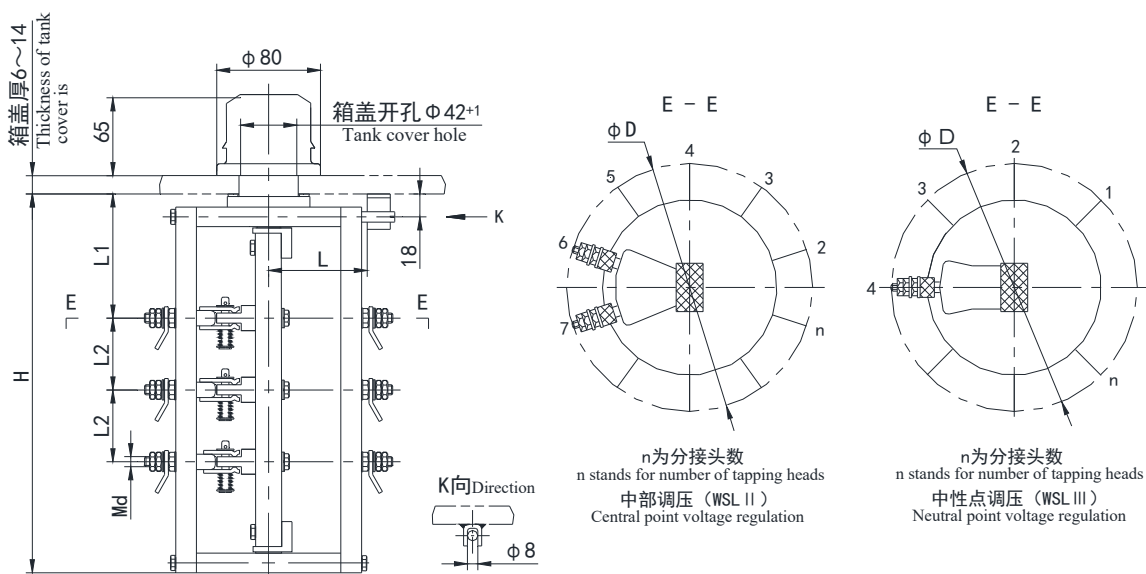

固定点中心距 L: Central Distance of the fixed points L. 额定电流 Rated Current 125A: Md=M8; 250A: Md=M10

4.2.4 立式开关安装尺寸 Outline Drawing of Vertical-type Switch

开关型号 Switch Type	额定电流 Rated Current (A)	额定电压 Rated Voltage (KV)	安 装 尺 寸 Mounting Dimension				
			L1	L2	H	L	D
WSL II 125/10-6×5L	125	10	97	65	312	75	192
WSL II 200、250/10-6×5L	200、250		102	70	332	75	200
WSL II 125/10-8×7~10×9L	125		97	65	312	85	212
WSL II 200、250/10-8×7~10×9L	200、250		102	70	332	85	220
WSL III 125/10-8×8~10×10L	125		97	65	312	100	250
WSL III 200、250/10-8×8~10×10L	200、250		90	70	332	100	242
WSL II 125、250/35-8×7~10×9L	125、250	35	170	130	588	100	250

4.2.5 箱顶式、钟罩式笼形开关外形图 Outline Drawings of Box-top Type, Bell Type and Cage-like Switches

箱顶式外形图 Outline Drawing of Box-top Type

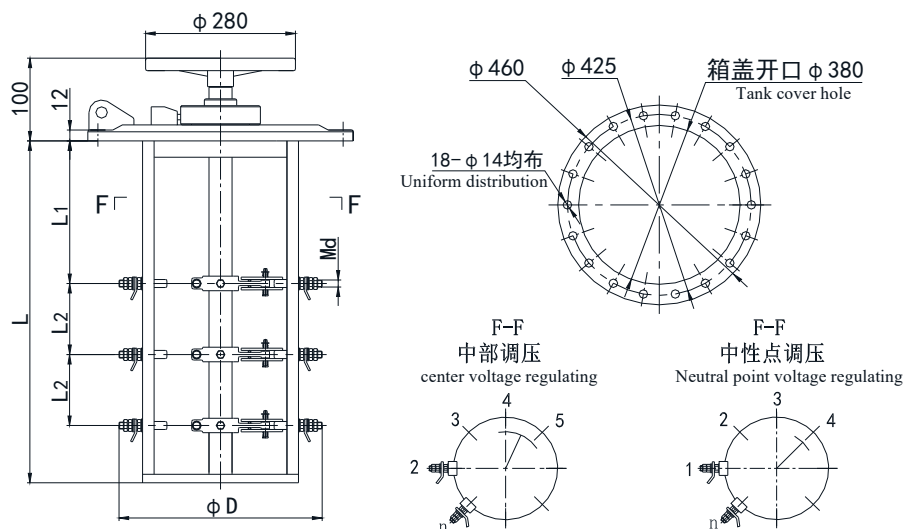

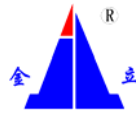

钟罩式外形图 Outline Drawing of Bell Type

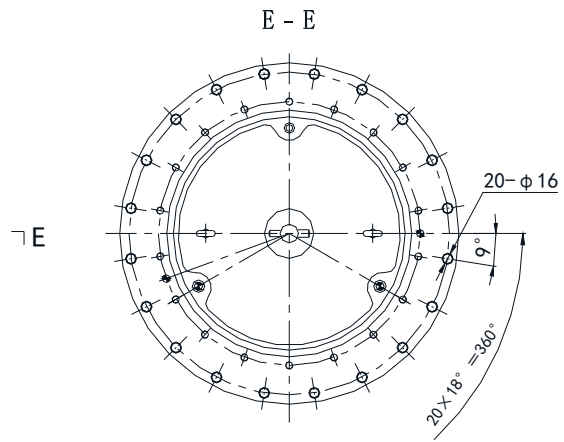
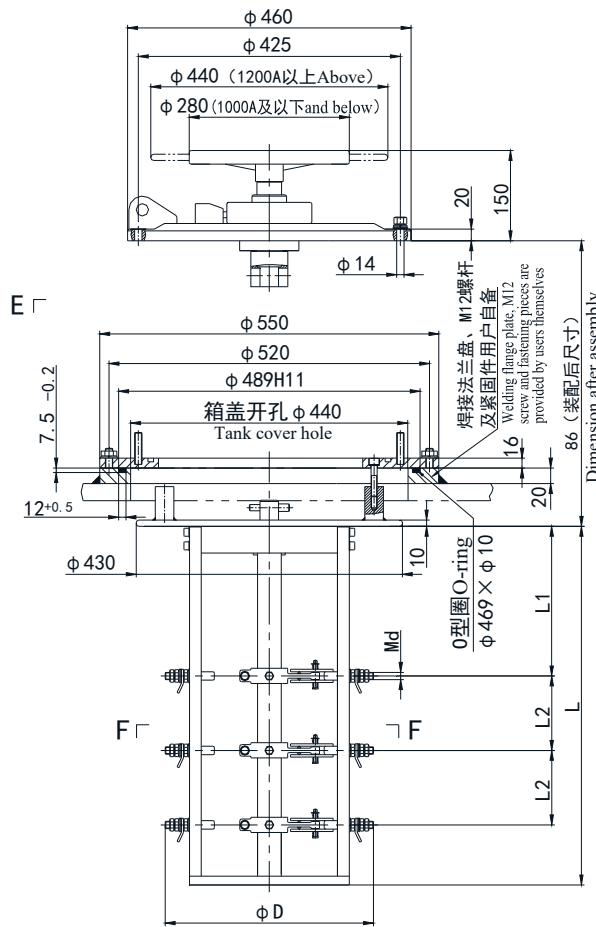

用于钟罩式油箱头部法兰安装尺寸图
Installation dimension drawing of head flange for Bell-Type oil tank

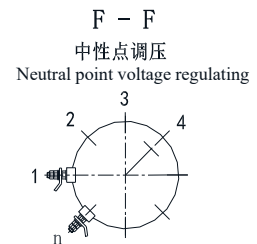
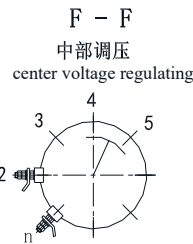

4.2.6 开关安装尺寸 Switch Mounting Dimension

开关型号 Switch Type	额定电流 Rated Current (A)	额定电压 Rated Voltage (KV)	安 装 尺 寸 Mounting Dimension			
			L1	L2	L	φD
WSL II 200~400/10-6×5~10×9 D (Z)	200~400	10	150	110	480	345
WSL III 200~400/10-5×5~10×10 D (Z)	200~400		150	110	480	345
WSL II 200~400/35-6×5~10×9 D (Z)	200~400	35	210	170	650	345
WSL III 200~400/35-5×5~10×10 D (Z)	200~400		210	170	650	345
WSL II 200~400/66-6×5~8×7 D (Z)	200~400	66	320	250	953	360
WSL III 200~400/66-5×5~8×8 D (Z)	200~400		320	250	953	360
WSL II 200~800/110-6×5 D (Z)	200~800	110	450	400	1370	360
WSL III 200~800/110-6×6 D (Z)	200~800		450	400	1370	360
WSL II 200~800/110-10×9 Z	200~800		450	400	1370	450
WSL III 200~800/110-10×10 Z	200~800		450	400	1370	450

* 额定电流 Rated Current: 200A、250A Md=M12; 400A Md=M16; 630A Md=M18
其他形式的开关接线端子 connecting terminal of Switch

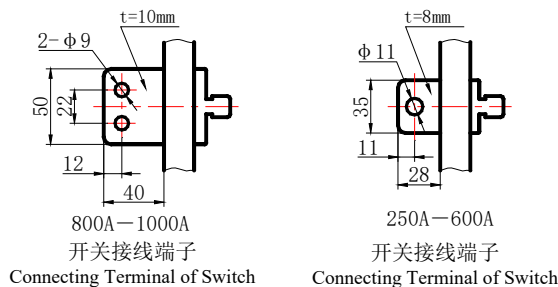

5. 开关安装方法: Installation Method of Switch

- 5.1 卧式开关安装时: 卸下防水帽, 拆下分接开关头部的圆螺母, 将分接开关水平放置, 置于油箱盖板下方。然后将分接开关头部法兰缓慢置于油箱盖板的 $\phi 43$ 开孔内, 装上大平垫, 用圆螺母固定并扭紧, 同时可靠固定开关尾部的 M12 螺栓, 调整好档位后, 安装上防水帽。(注意: ① 分接开关安装时, 要将密封圈放在变压器箱盖下方; 如果用户要求双密封安装时, 密封圈在变压器箱盖上方和下方各放一个。② 油箱盖板的开孔处不要过大, 和密封圈接触的平面要保证平整光滑, 否则会产生漏油现象)
- 5.2 箱顶式开关安装前应清洁所有的密封表面, 并在变压器安装法兰上放置耐油密封垫, 然后将开关缓慢吊入变压器箱体中, 整个吊装过程中, 应避免损坏开关接线端子, 在确认开关的安装位置正确无误后, 才可将开关固定在变压器安装法兰上。
- 5.3 钟罩式开关安装时将开关垂直放置, 拆去顶盖法兰, 拆下连接中间法兰与支撑法兰的螺钉, 取下中间法兰, 注意保存好拆下的零部件, 将开关吊起, 支撑法兰放置在变压器的支撑架上, 调整支撑法兰与顶盖法兰的相对位置, 加以固定, 起吊钟罩式箱盖, 罩住变压器, 清洁密封面, 装好密封垫, 将中间法兰固定在变压器的安装法兰上; 清洁中间法兰密封面, 装好密封垫, 最后装上顶盖法兰。
- 5.4 分接开关与箱盖固定好后再接线, 引线不应有任何张紧力和扭应力。

- 5.1 When installing the horizontal-type switch, first remove the protective shelter, unscrew the nut on the flange, let the switch flange come out through the open mouth of the box-cover, fix the position where the switch tail is welded together with the transformer using the bolt of M12; take care to keep the integrated level of switch, then install the upper parts back one by one.
- 5.2 Before installing the box-top type of switch, should clean all the sealed surfaces and put the oil-resistant packing seal on the mounting flange of the transformer, then slowly suspend the switch into the box-body of the transformer, in the whole course of the suspending installation, should take care to avoid damaging the connecting terminal of the switch. Having confirmed that the installation position of the switch is all right, you can fix the switch on the mounting flange of the transformer.
- 5.3 When installing bell-type switch, let the switch stand vertically, remove the flange of the top-cap, unscrew the screw connecting the middle flange with the supporting flange, remove the middle flange, take care to keep well the removed parts, suspend up the switch, put the supporting flange on the supporting shelf an the transformer, adjust the relative position of the supporting flange and the top-cap flange, fix it, lift the bell-type box-cover and cover the transformer, clean the sealed surface, put well the packing seal, fix the middle flange onto the mounting flange of the transformer; clean the sealed surface of the middle flange, install the packing seal well, at last mount the top-cap flange.
- 5.4 Hanving fixed the tap-changer and the box-cover, you can connect the leading wire which should not have any stretching force or torsional stress.

6. 开关使用方法: Switch Usage:

6.1 卧式开关使用方法 Usage of Horizontal-type Switch

- 1). 开关切换档位时, 首先将定位螺钉旋出开关连接法兰定位孔。
- 2). 在分接开关的分接位置上转换 3~5 次, 使档位数字位于开关定位件可视口的中心, 并且开关定位件的定位孔与开关连接法兰的定位孔重合;
- 3). 将定位螺钉拧入定位孔内固定紧, 以防变压器在运行中开关触头接触串动而将变压器烧毁;
- 4). 随后将防护罩拧紧。
- 1). When the switch transfers the stage-position, firstly, unscrew the fastening screw of tapered end for location (here after called locating screw);

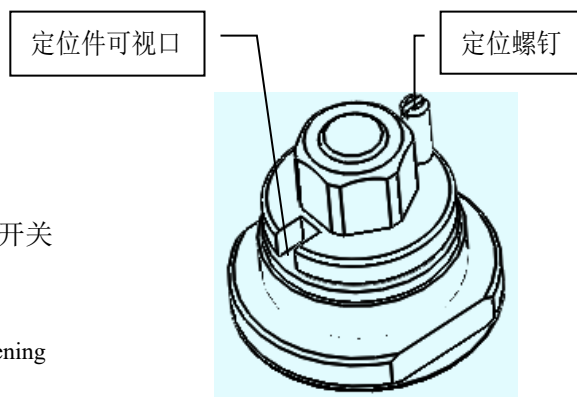

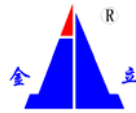

- 2). At the tap-changing position of the tap-changer, switch for 3~5 times to make the displayed digit of stage-position locate in the center of the viewing window of the locating part of the switch, and the locating hole of the locating part of the switch and the locating hole of the connecting flange of the switch coincide;
- 3). Screw the locating screw into the locating hole and fasten it to avoid burning out the transformer because of the movement caused when the switch contacts contact with each other;
- 4). At last screw up the protective shelter.
- 6.2 箱顶式、钟罩式开关切换档位时，先将定位件拉出 10mm，按需要转动手轮，并在分接开关的分接位置上转换 3~5 次，箭头指示档位数字中心后，定位件送入定位槽。
- 6.2 When you make the switch of the box-top type or bell-type transfer the stage-position, firstly, pull the locating part out for 10mm, turn the hand-wheel according to the need and transfer 3~5 times at the tap-changing position of the tap-changer, when the arrowhead indicating the center of the stage-position digit, put the locating part into the locating slot.
7. 开关使用注意事项: Matters Needing Attention for Using the Switch
- 7.1 使用环境温度:空气中-25℃~40℃,油中-25℃~100℃。
- 7.2 安装场所应无爆炸与腐蚀性气体。
- 7.3 分接开关组装前，一定要检查分接开关是否符合变压器型号要求，以免造成不应有的损失。
- 7.4 分接开关端子引线不得使分接开关受力变形，且引线应与运动部件留有间隙（一般为 10 mm）以免运动阻滞。
- 7.5 分接开关应随同变压器同时进行干燥处理，干燥后必须检查紧固件是否松动，若发现松动时，必须重新紧固及止退防松。
- 7.6 干燥后，必须将触点滴上变压器油后方可运行。
- 7.7 当开关在极限档位时，严禁向极限方向用力扳动手柄。
- 7.8 开关安装时，应保证开关上部与变压器箱盖有效接触，使开关上部分接地。
- 7.1 Using Ambient Temperature: in the air: -25℃~40℃, in the oil: -25℃~100℃.
- 7.2 There should be no explosive or corrosive gas in the installation place;
- 7.3 Before assembling the tap-changer, be sure to check to see if the tap-change is in accordance with the requirement of the transformer type so as to avoid causing the loss which should not take place.
- 7.4 The leading wire of the terminal of the tap-changer is not allowed to make the tap-changer get stressed and deformed, and there should be a gap between the leading wire and the moving part (normally it is 10mm) so as to avoid blocking the movement.
- 7.5 The dry treatment of the tap-changer and the transformer should be taken at the same time; having finished the dry treatment, must carry out the check to see if the fastening parts are loose or not; if so, must fasten them again and protect them from regressing in order to resist them getting loose.
- 7.6 After drying, must drop some transformer oil on the connecting points, otherwise you may not let the tap-changer operate.
- 7.7 When the switch is at the limit stage-position, strictly forbid to pull the handle to the limit direction further.
- 7.8 When installing the switch, should guarantee the effective contact between the upper part of the switch and the box-cover of the transformer and make the upper part of the switch connect to earth.

如有订货及特殊要求请与我公司技术部联系!

If you want to order the goods and have special requirement, please contact the Technical Department of our company!

辽宁金立电力电器有限公司

Liaoning Jinli Electric Power Electrical Appliance Co., Ltd.

地址 Add: 辽宁省丹东市振安区同兴镇

Tongxing Town Zhenan District Dandong City Liaoning Province

电话 Tel: 0415-6135555 (Telephone exchange) 6134555

传真 Fax: 0415-6131000