



LOW VOLTAGE ELECTRICAL PRODUCT CATALOG

- Miniature Circuit Breaker
- Molded Case Circuit Breaker
- Air Circuit Breaker
- AC Contactor



ZHEJIANG CHUANGQI ELECTRIC CO.,LTD.

🏠 WenzhouBase
No.18,ShahongRoad,BeibaixiangTown,YueqingCity,Wenzhou,ZhejiangProvince,China

🏠 JiaxingBase
No.61,ZhengyangWestRoad,XiuzhouDistrict,Jiaxing,ZhejiangProvince,China

☎ 0577-27878806

✉ marketing@chac-en.com

🌐 www.chac-electric.com



LINKEDIN



WEBSITE

V2026.03-CHAC-MKT



COMPANY INTRODUCTION

Zhejiang Chuangqi Electric Co., Ltd. (CHAC Electric) is a leading enterprise specializing in low-voltage electrical products, integrating R&D, manufacturing, and marketing. Our main products have obtained CCC, CE, and other certifications, and are widely exported to over 30 countries and regions, including the European Union, South America, Russia and other Commonwealth of Independent States countries, the Middle East, and Southeast Asia. For many consecutive years, CHAC Electric has ranked among the top exporters of low-voltage electrical products in Wenzhou, establishing itself as one of the industry leaders in the international sales of low-voltage electrical equipment in China.

Adhering to the core values of "Virtue, Integrity, and Lean Innovation," and through years of dedicated efforts, CHAC Electric has achieved outstanding performance and earned numerous honors, including "National High-Tech Enterprise," National-level "Green Factory," "AEO Advanced Certification Enterprise" by the General Administration of Customs, "Excellent Scenario of Intelligent Manufacturing" by the Ministry of Industry and Information Technology (MIIT), "National-Level Specialized, Sophisticated, Distinctive, and Innovative 'Little Giant' Enterprise," "National Patent-Intensive Product Certification," "Typical Innovation Achievement in National Advanced Manufacturing Clusters," "International Cooperation Case in Industrial Clusters" by MIIT, "Zhejiang Famous Trademark," "Zhejiang Export Famous Brand," "Zhejiang Specialized, Sophisticated, Distinctive, and Innovative SME," "Zhejiang Advanced-Level Smart Factory," "Zhejiang Service-Oriented Manufacturing Demonstration Enterprise," "Zhejiang Provincial Enterprise Technology Center," "Zhejiang Manufacturing Certification Enterprise," "Zhejiang Science and Technology-Based SME," "Zhejiang Ninth Batch of Big Data Application Demonstration Enterprise," "Zhejiang AAA-Level Contract and Credit Honoring Enterprise," "Zhejiang Pilot Enterprise for Implementation of National Data Management Standard (DCMM)."

In this new journey, CHAC Electric is committed to realizing its vision of becoming "an internationally leading lean intelligent manufacturing expert in low-voltage electrical products" and fulfilling its mission of "enabling safe electricity use to step into the smart era." With a focus on low-voltage electrical products and driven by innovation, the company is fully dedicated to enhancing its core competitiveness. It is progressively advancing its digital and intelligent transformation, promoting high-quality and sustainable development, and contributing to the growth of the regional economy and China's industrial electrical industry.

1995

Establishment Date

2

Digital Facility

60000+

Land Area



CHAC

**DEVELOPMENT
HISTORY**

2023

Zhejiang Chuangqi Electric Co.,Ltd.has completed its shareholding reformand prepare for IPO



2018

The Jiaxing Intelligent Manufacturing Base has been completed

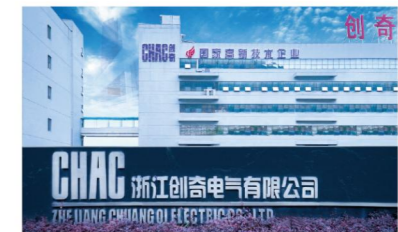

2012

Luogelang Group Limitedwas established



2007

The Wenzhou Intelligen Manufacturing Basehas been completed



1998

Wenzhou Luogelang Electrical Equipment Co.,Ltd. established



1995

Wenzhou Zhengli Electrical Appliance Co.,Ltd. was established in 1995 (the predecessor of the CHAC)



QUALITY REPUTATION

The products comply with international universal product certifications such as CCC, CE, and CB. The company has passed international management system certifications such as ISO9001, ISO14001, and OHSAS18001.

Zhejiang Chuangqi Electric Co., Ltd. possesses advanced research and manufacturing capabilities in the industry, persistently pioneering and self-regulating in the field of low-voltage electrical product manufacturing. From product testing to production certification, it has received comprehensive recognition from professional testing institutions and certification bodies, ultimately owning multiple core technologies, patents, and honors such as "Zhejiang Manufacturing Certification," "Zhejiang Famous Brand Product," and "Zhejiang Chuangqi High-tech Enterprise."



33

Invention Patent



152

Utility Model Patent



28

Design Patent



CHAC

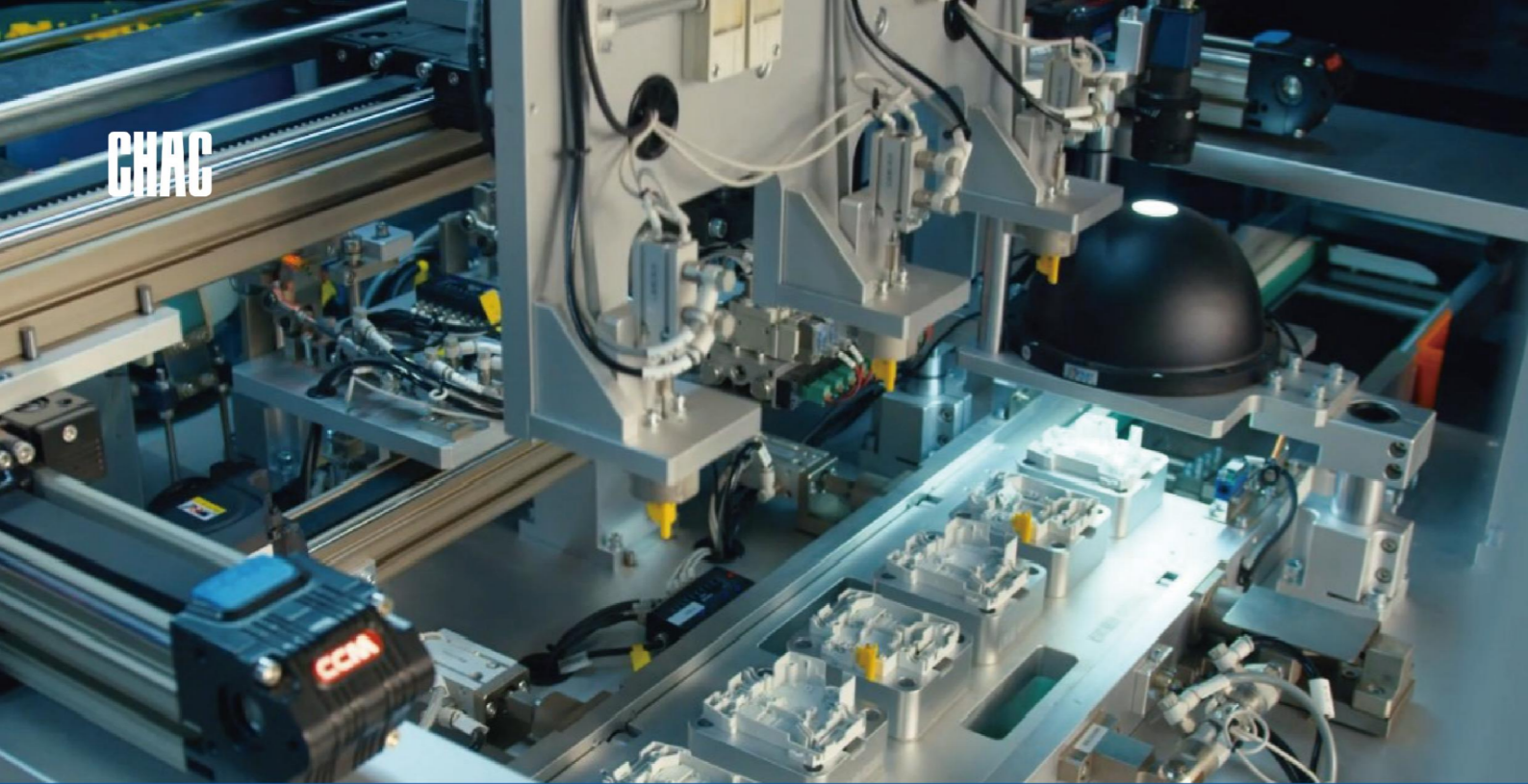

MANUFACTURING CAPACITY

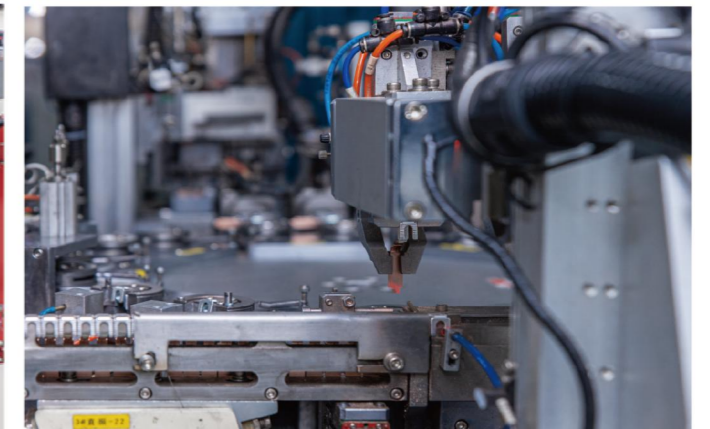
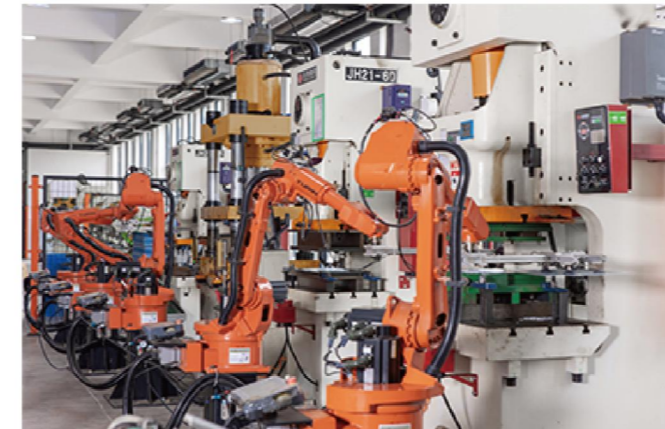

CHAC has a comprehensive low-voltage electrical product supply chain, covering everything from mold processing, metalworking, injection molding, precision machining to component processing, product assembly, testing, and packaging with fully automated production lines.



90%
Of Manufacturing Process Automated

85%
Of Production Machinery Self-developed

98%
Parts self-produced

100M POLES
MCB Annual Production Capacity



In addition, it has integrated SCADA automatic data collection system, KANBAN material kanban management system, WMA warehousing material management system, EMS energy management system, ANDON production abnormality management system, and QMS quality management system.



CONTENTS

01

MINIATURE CIRCUIT BREAKER

PXB6 Series

Miniature Circuit Breaker

- PXB6-63 / 01
- PXB6m-63 / 03
- PXB6H-63 / 05
- PXB6-125 / 07

DC Miniature Circuit Breaker

- PXB6DC-63 / 09
- PXB6HDC-63 / 11

Residual Current Breaker with Overcurrent

- PXB6L-63 / 13

Electromagnetic Residual Current Operated Circuit Breaker

- PXL6a-100 / 15

Isolator Switch

- PXD6-125 / 16

Accessories

- PXB6-OF / 17
- PXB6-SD / 18
- PXB6-MV MN / 19
- PXB6-MX / 20

PXB9 Series

Miniature Circuit Breaker

- PXB9-63 / 21
- PXB9N-32 / 23

Residual Current Circuit Breaker

- PXL9-63 / 25

Residual Current Breaker with Overcurrent

- PXB9L-40 / 27

DC Miniature Circuit Breaker

- CQB7DC-63 / 29

Smart Miniature Circuit Breaker

- CQB7ZNM-80 / 31
- CQB71R-100 / 33
- CQB7R-125 / 35

PXB2 Series

Miniature Circuit Breaker

- PXB2-63 / 37

Residual Current Breaker with Overcurrent

- PXB2Ln-63 / 39

CQB2 Series

Miniature Circuit Breaker

- CQB2-63 / 41
- CQB2-40 / 43
- CQB2-125 / 45
- CQB2H-63 / 47

Residual Current Breaker with Overcurrent

- CQB2LE-40 / 49
- CQB2LE-63 / 51
- CQB2LE-125 / 53
- CQB2HL-63 / 55

Isolator Switch

- CQD2-125 / 57

Accessories

- CQAF2(OF) / 58
- CQAS2(SD) / 59
- CQAM2(MX) / 60
- CQAU2(OUT) / 61
- CQAX2(MX+OF) / 62

CQB3 Series

Miniature Circuit Breaker

- CQB3-63 / 63

Residual Current Breaker with Overcurrent

- CQB3Ln-63 / 65
- CQB3LE-63 / 67

Auto-Reclosing Over/Under Voltage Protector

- CQB3GQ-80 / 69

Surge Protective Device

- EXS-T1T2-AC / 70

FB Series

Miniature Circuit Breaker

- FB2-63 / 71
- FB2H-63 / 73

Residual Current Breaker with Overcurrent

- FB2L-63 / 75
- FB2HL-63 / 77

CONTENTS

Other Products

Electromagnetic Residual Current Operated Circuit Breaker

- CQL14 / 79

Miniature Circuit Breaker

- CQB58 / 81

Over/Under Voltage & Over-Current Auto-Reclosing Protector

- CQGQA-63 / 83

WiFi Smart Circuit Breaker Protector

- CQGQS-63 / 85

WiFi Din Rail Switch (Tuya APP)

- CQGQE / 87

02

SWITCHGEAR ASSEMBLIES

Distribution Box

- CQMG20 / 89
- CQMG20A / 91
- CQMG20B / 92
- CQMG20C / 93

Distribution Block

- CQMG03 / 94

Indicator Lights

- CQIL6/7 / 95

Sockets

- CQP7 / 96
- CQP20 / 97

Electric Bell

- CQBE3 / 98

03

MOLDED CASE CIRCUIT BREAKER

CQM5 Series

- CQM5 / 99
- CQM5L / 108
- CQM5E / 114

CQM6 Series

- CQM6 / 133
- CQM6L / 143
- CQM6T/A, RT / 152
- CQM6E / 163

CQM7DC Series

- CQM7DC / 173

04

AIR CIRCUIT BREAKER

CQW2 Series

- CQW2 / 175

05

INDUSTRIAL CONTROL

AC Contactor

- CQC6 / 191

Thermal Overload Relay

- CQR2 / 197

Motor Protection Device

- CQV2 / 202

06

HIGH VOLTAGE DC CONTACTOR

STE Series

- STE1 / 207
- STE2 / 213
- STE3 / 218

PXB6-63

Miniature Circuit Breaker



Product Features

- High interruption rating capabilities
- Overload & short circuit protection
- Positive isolation
- Suitable for industrial, commercial, high-rise and civil residences circuit protection

Type designation

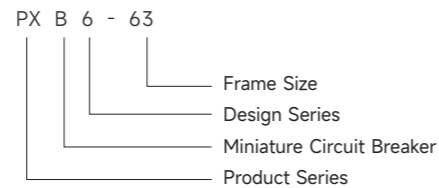

Tripping curves

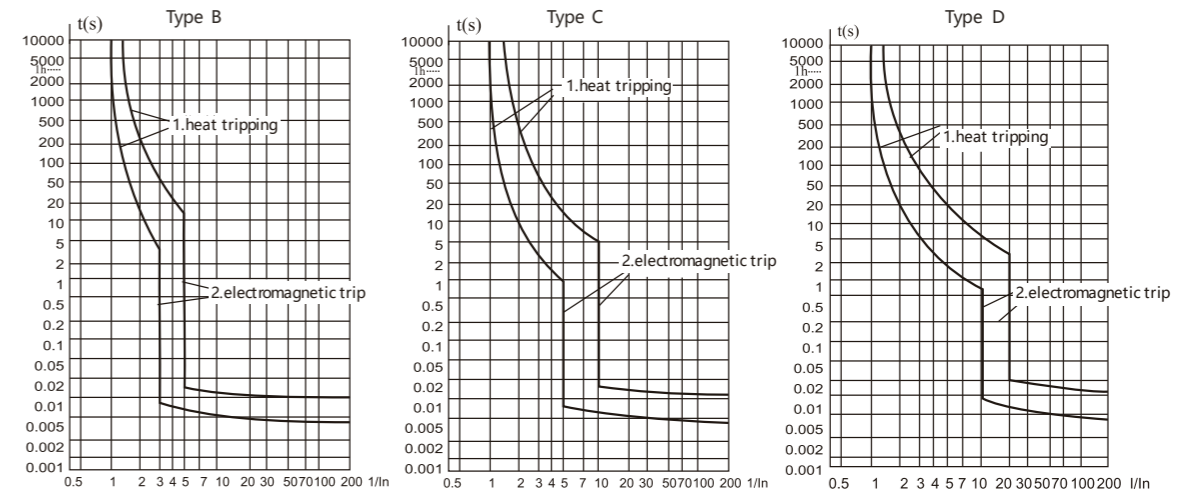

Technical Specifications

Parameter	
Rated Insulation Voltage (Ui)	500V
Rated Impulse Withstand Voltage (Uimp)	4000V
Rated Current (In)	6, 10, 16, 20, 25, 32, 40, 50, 63
Rated Frequency	50Hz / 60Hz
Number of Poles	1P, 2P, 3P, 4P
Rated Short-Circuit Breaking Capacity (Icu = Ics)	4500A
Mechanical Life	≥10000
Electrical Life	≥4000
Tripping curves	B, C, D
Terminal center distance	45mm
Protection Class	IP20
Standard	IEC60898 -1, GB/T10963 . 1
Certification	CCC

Conductor requirements and cross section

Copper cross-section(mm ²)	Rated current In(A)
1	In≤6
1.5	6 < In≤13
2.5	13 < In≤20
4	20 < In≤25
6	25 < In≤32
10	32 < In≤50
16	50 < In≤63

Dimensions(mm)

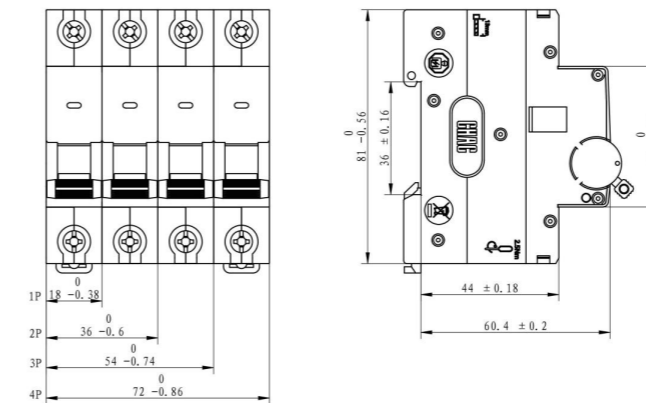

Ordering Specification

Please specify the following when ordering:

- 1.Product Model: PXB6-63
 - 2.Number of Poles: 1P, 2P, 3P, 4P
 - 3.Rated Current & Tripping Curve: [e.g., C/16A]
 - Tripping Curve (Type): B, C, D
 - Rated Current (In): 6, 10, 16, 20, 25, 32, 40, 50, 63A
 - 5.Quantity: [e.g., 100 pcs]
- Ordering Example:
PXB6-63 2P C/16A 100 pcs

Tripping Characteristics (Reference Temperature: 30°C)

Item	Tripping Curve	Test Current (A)	Initial Status	Time limit for tripping or non-tripping	Expected result	Remarks
a	B, C, D	1.13In	Cold	$t \leq 1h$	Non-tripping	Current smoothly rises to specified value within 5s
b	B, C, D	1.45In	Following item a test	$t < 1h$	Tripping	
c	B, C, D	2.55In	Cold	$1s < t < 60s$ (In ≤ 32A) $1s < t < 120s$ (In > 32A)	Tripping	Switch on the power supply by closing the auxiliary switch
d	B C D	3In 5In 10In	Cold	$t \leq 0.1s$	Non-tripping	
e	B C D	5In 10In 20In	Cold	$t < 0.1s$	Tripping	Switch on the power supply by closing the auxiliary switch

Note: The term "cold" means that the test is carried out at a reference calibration temperature without load before the test.

PXB6m-63

Miniature Circuit Breaker



Product Features

- Overload Protection - Reliably prevents damage from circuit overload.
- Short-Circuit Protection - Quickly interrupts short-circuit currents for safety.
- Isolation Protection - Provides positive isolation with clear ON/OFF indication.
- Suitable for terminal distribution in building, power, and infrastructure industries.

Type designation

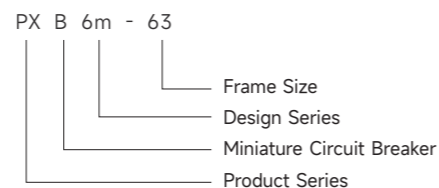

Tripping curves

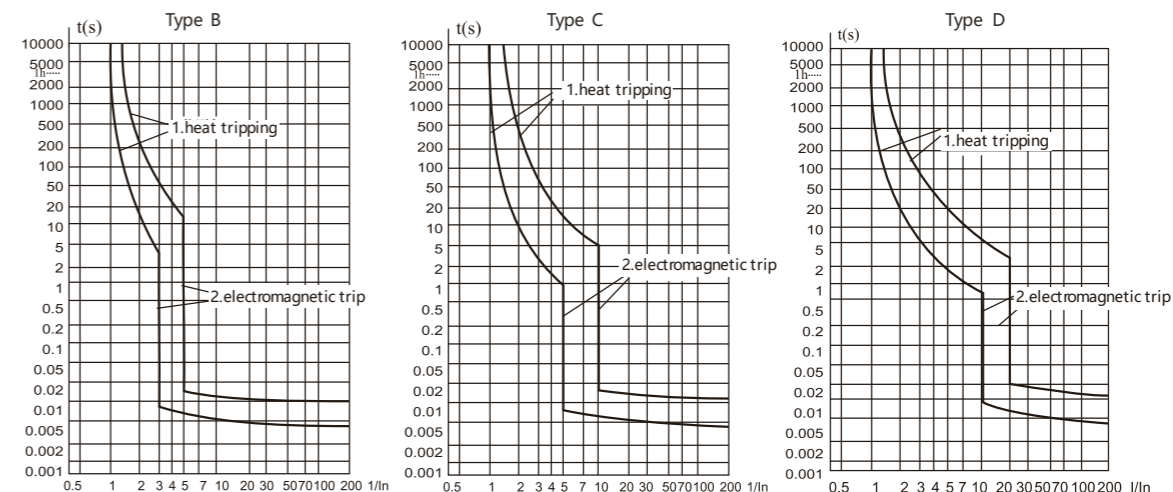

Conductor requirements and cross section

Copper cross-section(mm ²)	Rated current In(A)
1	In ≤ 6
1.5	6 < In ≤ 13
2.5	13 < In ≤ 20
4	20 < In ≤ 25
6	25 < In ≤ 32
10	32 < In ≤ 50
16	50 < In ≤ 63

Dimensions(mm)

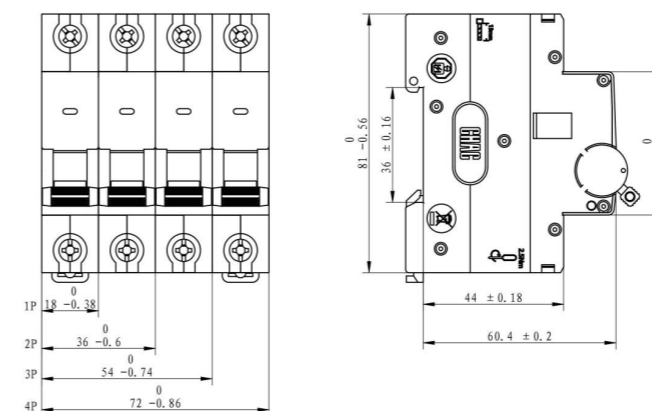

Ordering Specification

Please specify the following when ordering:

- 1.Product Model: PXB6m-63
 - 2.Number of Poles: 1P, 2P, 3P, 4P
 - 3.Rated Current & Tripping Curve: [e.g., C/16A]
 - Tripping Curve (Type): B, C, D
 - Rated Current (In): 6, 10, 16, 20, 25, 32, 40, 50, 63A
 - 5.Quantity: [e.g., 100 pcs]
- Ordering Example:
PXB6m-63 2P C/16A 100 pcs

Technical Specifications

Parameter	
Rated Insulation Voltage (Ui)	500V
Rated Impulse Withstand Voltage (Uimp)	4000V
Rated Current (In)	6, 10, 16, 20, 25, 32, 40, 50, 63
Rated Frequency	50Hz / 60Hz
Number of Poles	1P, 2P, 3P, 4P
Rated Short-Circuit Breaking Capacity (Icu = Ics)	6000A
Mechanical Life	≥10000
Electrical Life	≥4000
Tripping curves	B, C, D
Terminal center distance	45mm
Protction Class	IP20
Standard	IEC60898 -1, GB/T10963 . 1
Certification	CCC

Tripping Characteristics (Reference Temperature: 30°C)

Item	Tripping Curve	Test Current (A)	Initial Status	Time limit for tripping or non-tripping	Expected result	Remarks
a	B, C, D	1.13In	Cold	t ≤ 1h	Non-tripping	Current smoothly rises to specified value within 5s
b	B, C, D	1.45In	Following item a test	t < 1h	Tripping	
c	B, C, D	2.55In	Cold	1s < t < 60s (In ≤ 32A) 1s < t < 120s (In > 32A)	Tripping	
d	B	3In	Cold	t ≤ 0.1s	Non-tripping	Switch on the power supply by closing the auxiliary switch
	C	5In				
	D	10In				
e	B	5In	Cold	t < 0.1s	Tripping	Switch on the power supply by closing the auxiliary switch
	C	10In				
	D	20In				

Note: The term "cold" means that the test is carried out at a reference calibration temperature without load before the test.

PXB6H-63

Miniature Circuit Breaker



Product Features

- High Breaking Capacity - Rated breaking capacity up to 10000A for severe faults.
- Overload and Short-Circuit Protection - Integrated protection enhances circuit reliability.
- Isolation Function - Safe isolation for easy maintenance.

Type designation

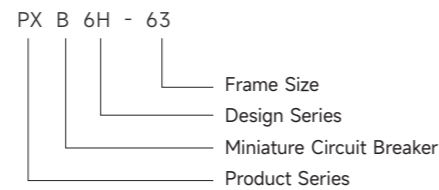

Tripping curves

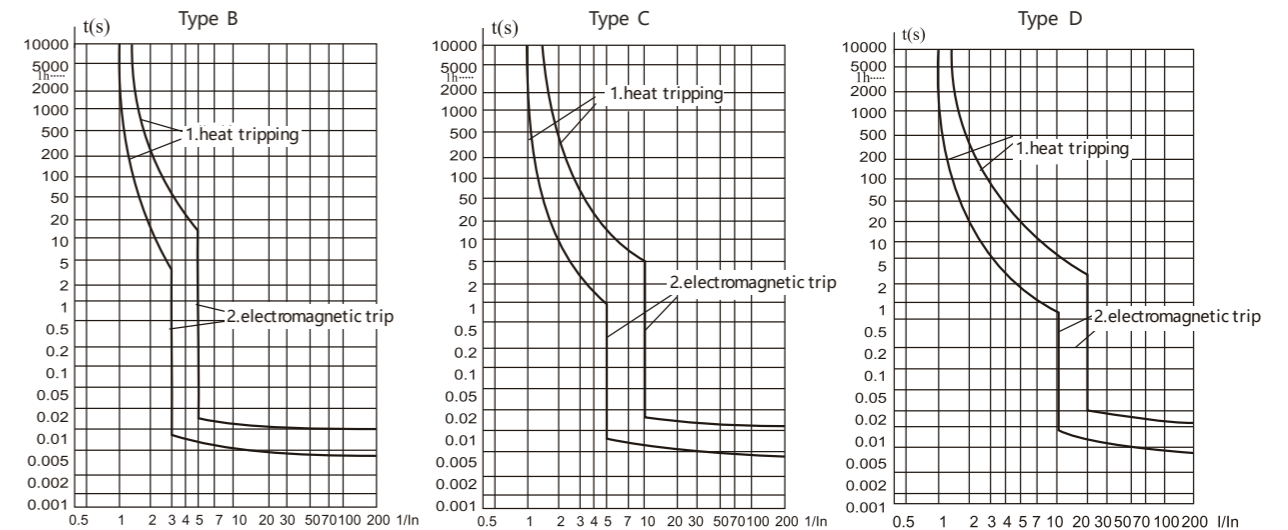

Technical Specifications

Parameter	
Rated Insulation Voltage (Ui)	500V
Rated Impulse Withstand Voltage (Uimp)	4000V
Rated Current (In)	6, 10, 16, 20, 25, 32, 40, 50, 63
Rated Frequency	50Hz / 60Hz
Number of Poles	1P, 2P, 3P, 4P
Rated Short-Circuit Breaking Capacity (Icu = Ics)	10000A
Mechanical Life	≥10000
Electrical Life	≥4000
Tripping curves	B, C, D
Terminal center distance	45mm
Protection Class	IP20
Standard	IEC60898 -1, GB/T10963.1
Certification	CCC

Conductor requirements and cross section

Copper cross-section(mm ²)	Rated current In(A)
1	In≤6
1.5	6 < In≤13
2.5	13 < In≤20
4	20 < In≤25
6	25 < In≤32
10	32 < In≤50
16	50 < In≤63

Tripping Characteristics (Reference Temperature: 30°C)

Item	Tripping Curve	Test Current (A)	Initial Status	Time limit for tripping or non-tripping	Expected result	Remarks
a	B, C, D	1.13In	Cold	t ≤ 1h	Non-tripping	Current smoothly rises to specified value within 5s
b	B, C, D	1.45In	Following item a test	t < 1h	Tripping	
c	B, C, D	2.55In	Cold	1s < t < 60s (In ≤ 32A) 1s < t < 120s (In > 32A)	Tripping	
d	B	3In	Cold	t ≤ 0.1s	Non-tripping	Switch on the power supply by closing the auxiliary switch
	D	10In				
e	B	5In	Cold	t < 0.1s	Tripping	Switch on the power supply by closing the auxiliary switch
	C	10In				
	D	20In				

Note: The term "cold" means that the test is carried out at a reference calibration temperature without load before the test.

Dimensions(mm)

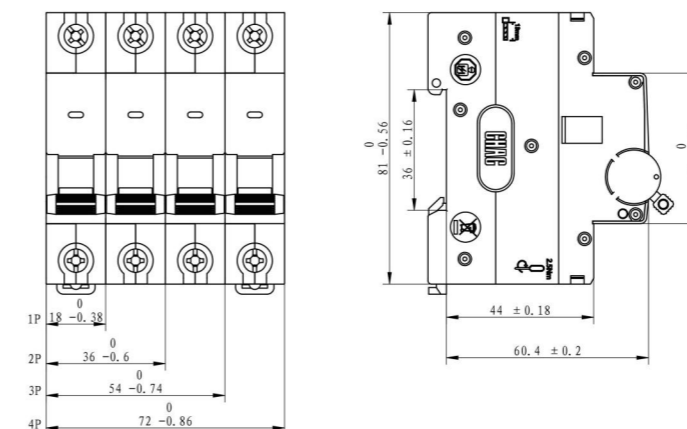

Ordering Specification

Please specify the following when ordering:

- 1.Product Model: PXB6H-63
 - 2.Number of Poles: 1P, 2P, 3P, 4P
 - 3.Rated Current & Tripping Curve: [e.g., C/16A]
 - Tripping Curve (Type): B, C, D
 - Rated Current (In): 6, 10, 16, 20, 25, 32, 40, 50, 63A
 - 4.Quantity: [e.g., 100 pcs]
- Ordering Example:
PXB6H-63 2P C/16A 100 pcs

PXB6-125

Miniature Circuit Breaker



Product Features

- High Rated Current - Rated current up to 125A for heavy-load applications.
- High Breaking Capacity - Ultimate breaking capacity of 12500A ensures reliability.
- Overload and Short-Circuit Protection - Comprehensive protection for distribution lines.
- Industrial and Commercial Use - Widely used in industrial and commercial settings.

Type designation

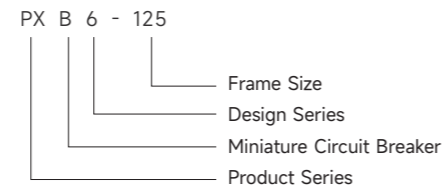

Technical Specifications

Parameter	
Rated voltage (V)	230V(1P)、400V(2P, 3P, 4P)
Rated current (A)	6000V
Number of poles	10, 16, 20, 25, 32, 40, 50, 63, 80, 100, 125A
Tripping curves	50Hz
Rated short-circuit breaking capacity I _{cu} (A)	1P, 2P, 3P, 4P
Rated service short-circuit breaking capacity I _{cs} (A)	12500A
Rated impulse withstand voltage U _{imp} (V)	7500A
Mechanical life	≥10000
Electrical life	≥4000
Tripping curves	C, D
Protection class	IP20
Installation category	II&III
Standards	IEC60898 -1、GB/T10963 . 1

Tripping Characteristics (Reference Temperature: 30°C)

Item	Tripping Curve	Test Current (A)	Initial Status	Time limit for tripping or non-tripping	Expected result	Remarks
a	C, D	1.05I _n	Cold	1h(I _n ≤63A) 2h(I _n >63A)	Non-tripping	Current smoothly rises to specified value within 5s
b	C, D	1.3I _n	Following item a test	1h(I _n ≤63A) 2h(I _n >63A)	Tripping	
c	C, D	2I _n	Cold	1s<t<300s	Tripping	
d	C	8I _n ×80%	Cold	t ≤ 0.2s	Non-tripping	Switch on the power supply by closing the auxiliary switch
	D	12I _n ×80%				
e	C	8I _n ×80%	Cold	t < 0.2s	Tripping	Switch on the power supply by closing the auxiliary switch
	D	12I _n ×80%				

Note: The term "cold" means that the test is carried out at a reference calibration temperature without load before the test.

Tripping curves

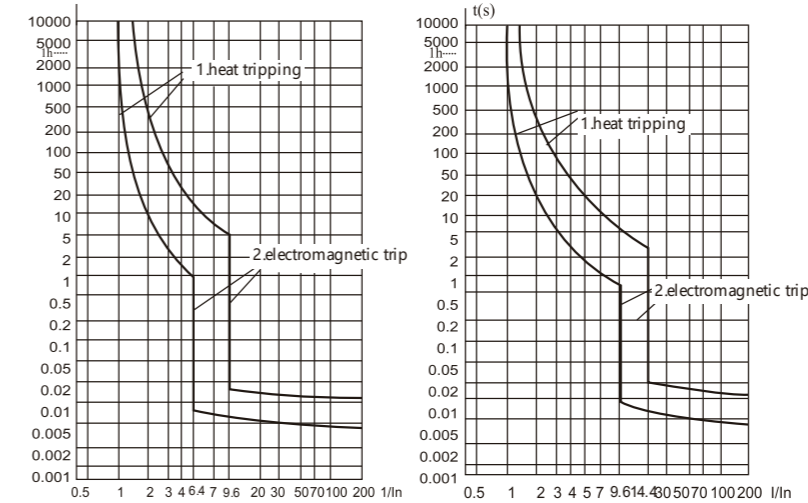

Conductor requirements and cross section

Copper cross-section(mm ²)	Rated current I _n (A)
1	I _n ≤6
1.5	6 < I _n ≤13
2.5	13 < I _n ≤20
4	20 < I _n ≤25
6	25 < I _n ≤32
10	32 < I _n ≤50
16	50 < I _n ≤63
25	65 < I _n ≤80
35	80 < I _n ≤100
50	100 < I _n ≤125

Dimensions(mm)

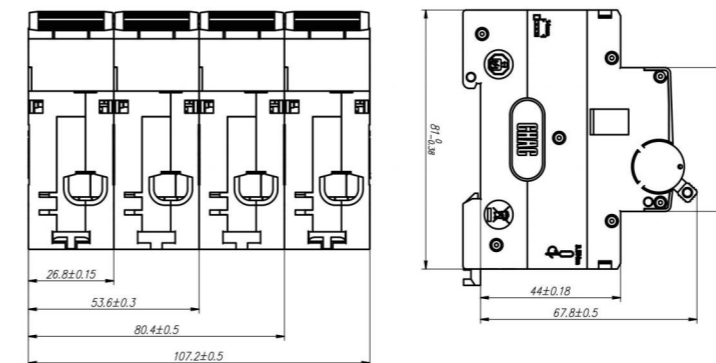

Ordering Specification

Please specify the following when ordering:

- 1.Product Model: PXB6-125
 - 2.Number of Poles: 1P, 2P, 3P, 4P
 - 3.Rated Current & Tripping Curve: e.g., C/32A
 - Tripping Curve (Type): C, D
 - Rated Current (I_n): 10A, 16A, 20A, 25A, 32A, 40A, 50A, 63A, 80A, 100A, 125A
 - 4.Quantity: e.g., 100 pcs
- Ordering Example:
PXB6-125 3P D/63A 100 pcs

PXB6DC-63

DC Miniature Circuit Breaker



Product Features

- Designed for 24V-250V DC systems, available in 1P & 2P.
- Breaking capacity up to 10kA for severe short-circuits.
- Mechanical life $\geq 10,000$ operations, ideal for demanding applications like telecom cabinets.
- Complies with GB/T14048.2 & IEC60947-2, CCC certified.

Type designation

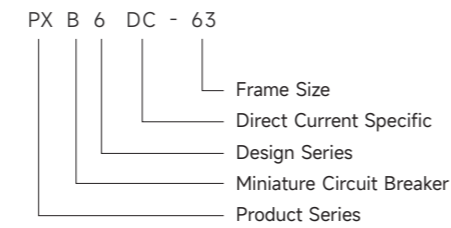

Tripping curves

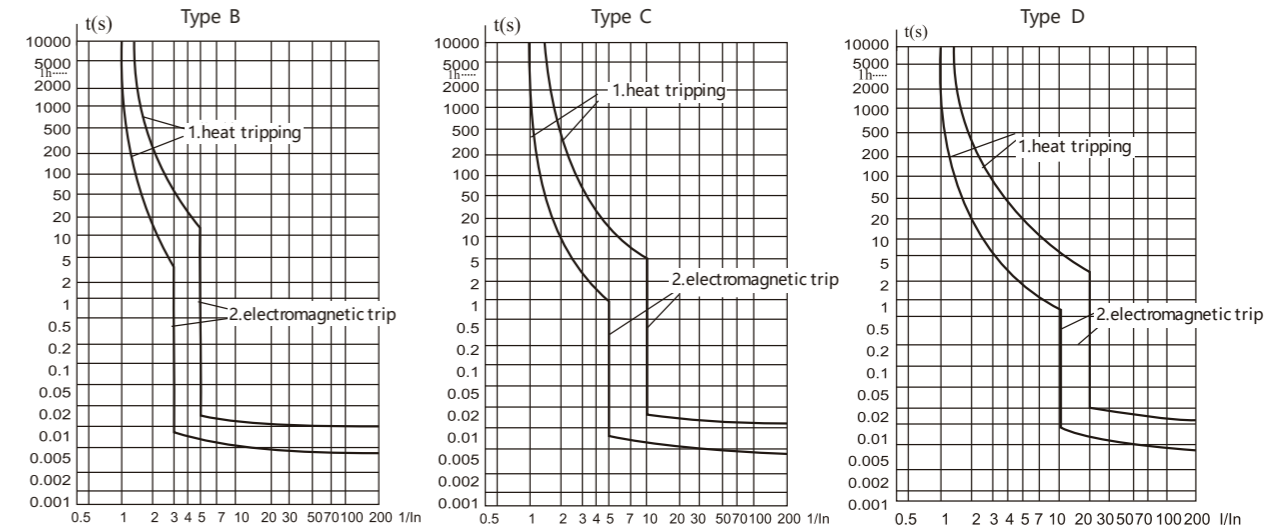

Technical Specifications

Parameter	
Rated Voltage (V)	1P DC24V/48V/80V/110V/125V 2P DC24V/48V/80V/110V/125V/160V/220V/250V
Rated Current (A)	1, 1.6, 2, 2.5, 3, 4, 5, 6, 10, 13, 16, 20, 25, 32, 40, 50, 63
Rated Insulation Voltage (Ui)	500V
Ultimate Breaking Capacity (Icu) (kA)	10
Service Breaking Capacity (Ics) (kA)	7.5
Mechanical Life (operations)	≥ 10000
Electrical Life (operations)	≥ 1500
Termination Capacity	$\leq 25\text{mm}^2$
Tightening Torque (N·m)	2.5
Protction Class	IP20
Standard	GB/T14048.2、IEC60947-2
Certification	CCC

Dimensions(mm)

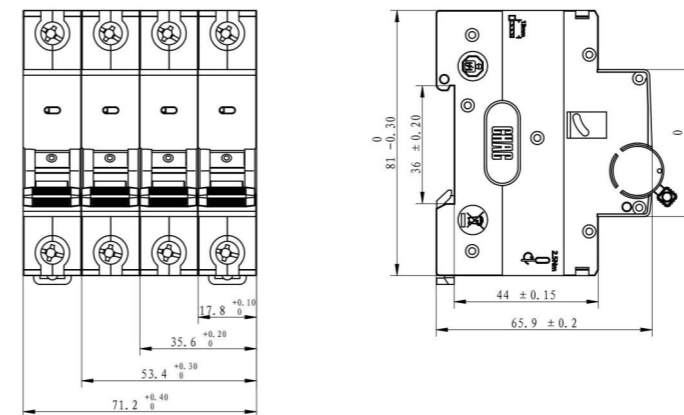

Ordering Specification

Please specify the following when ordering:

- 1.Product Model: PXB6DC-63
 - 2.Number of Poles: 1P, 2P,
 - 3.Rated Current & Tripping Curve: [e.g., 16A]
 - Rated Current (In): 1, 1.6, 2, 2.5, 3, 4, 5, 6, 10, 13, 16, 20, 25, 32, 40, 50, 63A
 - 5.Quantity: [e.g., 100 pcs]
- Ordering Example:
PXB6DC-63 2P 16A 100 pcs

Tripping Characteristics (Reference Temperature: 30°C)

Item	Test Current (A)	Initial Status	Time limit for tripping or non-tripping	Expected result	Remarks
a	1.05In	Cold	$t \leq 1h$	Non-tripping	Current smoothly rises to specified value within 5s
b	1.3In	Following item a test	$t < 1h$	Tripping	
c	2.55In	Cold	$1s < t < 60s$ (In $\leq 32A$) $1s < t < 120s$ (In $> 32A$)	Tripping	
d	4In, 8In, 12In ($\pm 20\%$)	Cold	$t \leq 0.2s$	Tripping	Circuit switched on by closing an auxiliary switch. Verifies rapid breaking capability.

Note: The term "cold" means that the test is carried out at a reference calibration temperature without load before the test.

PXB6HDC-63

DC Miniature Circuit Breaker



Product Features

- DC Specialized - Specifically designed for DC circuits with a rated voltage up to 1000V.
- Wide Current Range - Comprehensive rated currents from 0.5A to 63A to meet diverse application needs.
- High Environmental Endurance - Operational temperature range from -25°C to +70°C, suitable for harsh conditions.

Type designation

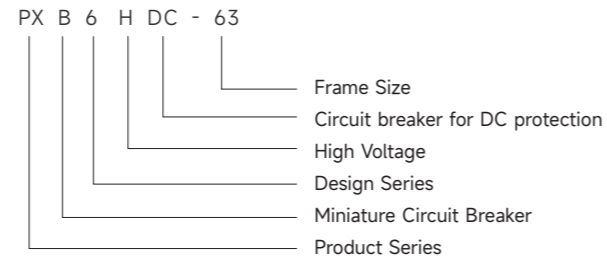

Dimensions(mm)

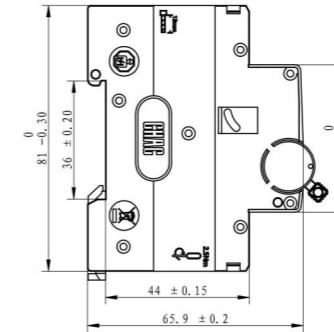
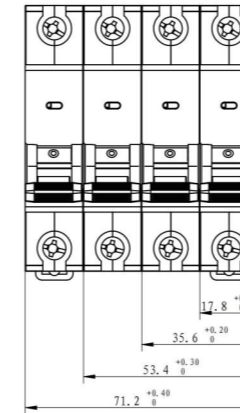

Ordering Specification

Please specify the following when ordering:

- 1.Product Model: PXB6HDC-63
 - 2.Number of Poles: 1P, 2P, 3P, 4P
 - 3.Rated Current : [e.g., 16A]
 - Rated Current (In): 1, 1.6, 2, 2.5, 3, 4, 5, 6, 8, 10, 13, 16, 20, 25, 32, 40, 50, 63A
 - 5.Quantity: [e.g., 100 pcs]
- Ordering Example:
PXB6HDC-63 2P 16A 100 pcs

Technical Specifications

Parameter	
Rated Voltage (V)	1P DC250V、2P DC500V、3P DC750V、4P DC1000V
Rated Current (A)	1, 1.6, 2, 2.5, 3, 4, 5, 6, 8, 10, 13, 16, 20, 25, 32, 40, 50, 63
Rated Insulation Voltage (Ui)	1000V
Number of Poles	1P, 2P, 3P, 4P
Service Breaking Capacity (Ics) (kA)	6
Mechanical Life (operations)	≥ 10,000 operations
Electrical Life (operations)	≥ 1,500 operations (at rated conditions)
Termination Capacity	≤25mm ²
Tightening Torque (N·m)	2.5
Protction Class	IP20
Operating Temperature	-25°C ~ +70°C
Standard	GB/T 14048.2、IEC60947-2

Tripping Characteristics (Reference Temperature: 30°C)

Item	Test Current (A)	Initial Status	Time limit for tripping or non-tripping	Expected result	Remarks
a	1.05In	Cold	t ≤ 1h	Non-tripping	Current smoothly rises to specified value within 5s
b	1.3In	Following item a test	t < 1h	Tripping	
c	2.55In	Cold	1s < t < 60s (In ≤ 32A) 1s < t < 120s (In > 32A)	Tripping	
d	4In、8In、12In (±20%)	Cold	t ≤ 0.2s	Tripping	Circuit switched on by closing an auxiliary switch. Verifies rapid breaking capability.

Note: The term "cold" means that the test is carried out at a reference calibration temperature without load before the test.

PXB6L-63

Residual Current Circuit Breaker with Overcurrent Protection - Electronic Type



Product Features

- Earth Leakage Protection - Detects electric shock or leakage current and cuts off power rapidly.
- Overload Protection - Prevents equipment damage from circuit overload.
- Short-Circuit Protection - Responds to short-circuit faults for enhanced safety.
- Fast Response - Leakage tripping time $\leq 0.1s$ to ensure personal safety.

Type designation

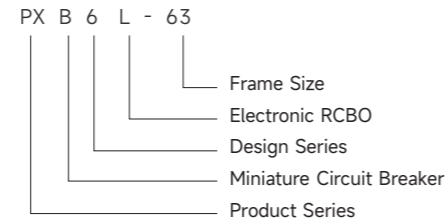

Technical Specifications

Parameter	
Rated Voltage (V)	230V~(1P+N)/400V~(3P+N)
Rated Current (A)	6、10、16、20、25、32、40、50、63
Number of Poles	1P+N、3P+N
Rated Short-Circuit Breaking Capacity Ics (A)	6000A
Rated Residual Operating Current $I_{\Delta n}$ (mA)	30、50、100、300
Rated Residual Non-Operating Current $\Delta I_{\Delta no}$ (mA)	0.5 $I_{\Delta n}$
Rated Residual Make and Break Capacity $I_{\Delta m}$ (A)	2000A
Residual Current Tripping Threshold	$\leq 0.1s$
Residual Current Trip Type	AC Type、A Type
Mechanical Life	≥ 15000
Electrical Life	≥ 10000
Tripping curves	B、C、D
Pollution Degree	2
Protection Class	IP 20
Installation Category	III
Standards	IEC61009-1, GB/T16917.1
Certification	CCC

Tripping Characteristics (Reference Temperature: 30°C)

Item	Tripping Curve	Test Current (A)	Initial Status	Time limit for tripping or non-tripping	Expected result	Remarks
Delay	≤ 63	Cold	1.13 I_n	$\leq 1h$	Non-tripping	
Delay	≤ 63	Following previous test	1.45 I_n	$< 1h$	Tripping	Current smoothly rises to specified value in 5s
Delay	≤ 32	Cold	2.55 I_n	1 $t < 60s$	Tripping	
Delay	> 32	Cold	2.55 I_n	1 $t < 120s$	Tripping	
Instantaneous	Any value	Cold	3、5、10 I_n	$\leq 0.1s$	Non-tripping	B、C、D
Instantaneous	Any value	Cold	5、10、20 I_n	$< 0.1s$	Tripping	B、C、D

Note: The term "cold" means that the test is carried out at a reference calibration temperature without load before the test.

Tripping curves

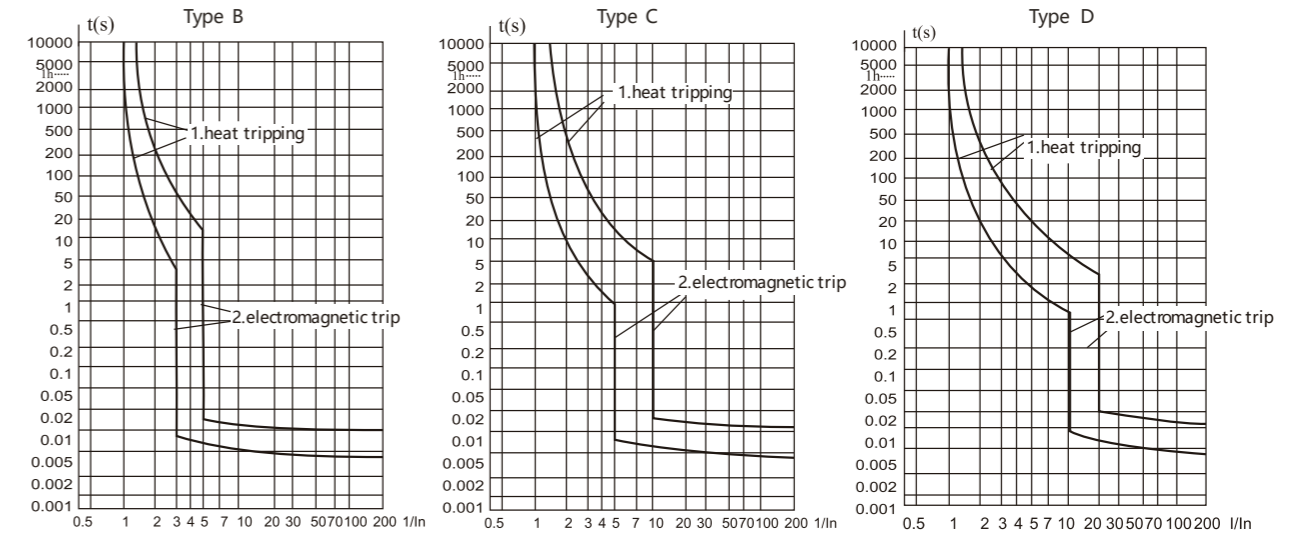

Conductor requirements and cross section

Copper cross-section(mm ²)	Rated current I_n (A)
1	$I_n \leq 6$
1.5	6 < $I_n \leq 13$
2.5	13 < $I_n \leq 20$
4	20 < $I_n \leq 25$
6	25 < $I_n \leq 32$
10	32 < $I_n \leq 50$
16	50 < $I_n \leq 63$

Dimensions(mm)

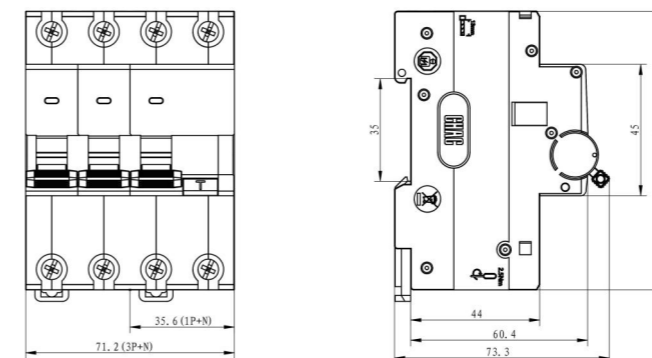

Ordering Specification

Please specify the following when ordering:

- Product Model: PXB6L-63
- Number of Poles: 1P+N, 3P+N
- Rated Current & Tripping Curve: e.g., C/25A
 - Tripping Curve (Type): B, C, D
 - Rated Current (I_n): 6A, 10A, 16A, 20A, 25A, 32A, 40A, 50A, 63A
- Residual Current Operation:
 - Residual Current Type: AC, A
 - Rated Residual Operating Current ($I_{\Delta n}$): 30mA, 50mA, 100mA, 300mA
- Quantity: e.g., 100 pcs
- Ordering Example: PXB6L-63 1P+N C/25A 30mA AC 100 pcs

PXL6a-100

Electromagnetic Residual Current Operated Circuit Breaker



Product Features

- High-Current Range: Industrial-grade with multiple high-rated current options up to 100A.
- Strong Protection: Powerful 6kA short-circuit breaking capacity for severe fault conditions.
- Rugged & Reliable: High mechanical life for demanding and frequent operation.
- System Flexibility: Available in 2P and 4P configurations for single or three-phase systems.

Type designation



Technical Specifications

Parameter	
Rated Voltage	230V AC(1P+N);400V AC(3P+N)
Rated Current (A)	25A、40A、63A、80A、100A
Rated Residual Operating Current	0.03A、0.1A、0.3A
Rated Residual Non-Operating Current	0.5I _{Δn}
Type of Residual Current (with DC component)	AC type、A type(I _n =25、40、63A)
Number of Poles	2P、4P
Rated Conditional Short-Circuit Current	6000A
Rated Conditional Residual Short-Circuit Current	6000A
Rated Making and Breaking Capacity	500A (I _n =25、40A) ; 10I _n (63、80、100A)
Rated Residual Making and Breaking Capacity	500A (I _n =25、40A) ; 10I _n (63、80、100A)
Tightening Torque	(2.5 ~ 3.0) N.m
Protection Class	IP20
Pollution Degree	2
Installation Category	II
Standards	GB 16916.1, IEC61008-1

Tripping Characteristics (Reference Temperature: 30°C)

I _n (A)	I _{Δn} (A)	Breaking time when the residual current equals the following values (s)					
		I _{Δn}	2I _{Δn}	5I _{Δn}	5A、10A、20A、50A、100A、200A	I _{Δt}	
25 ~ 100A	0.03、0.1、0.3	0.1	0.05	0.04	0.04	0.04	0.04

I _n (A)	Number of operating cycles		Operating frequency (cycles per hour)
	Number of on-load operating cycles	Number of no-load operating cycles	
25A	2000	2000	240
40A、63A、80A、100A	2000	1000	120

Dimensions(mm)

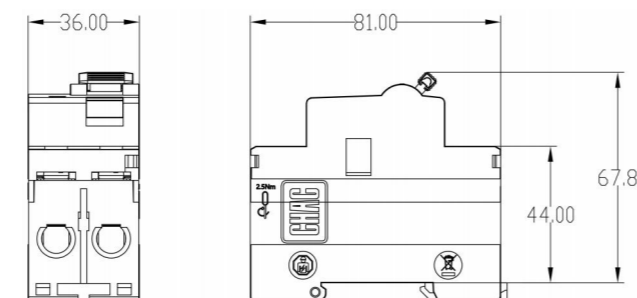

PXD6-125

DSL Isolator



Product Features

- Electrical Isolation - Provides safe isolation with clear ON/OFF position indication.
- High Short-Time Withstand Current - Rated short-time withstand current of 12I_e for strong fault resistance.
- Main Switch Application - Suitable as a main switch in terminal assembly devices.

Type designation

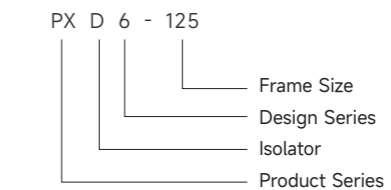

Technical Specifications

Parameter	
Rated Insulation Voltage U _i (V)	500V
Rated Operational Voltage U _e (V)	230V/400(1P), 400V(2P、3P、4P)
Rated Operational Current I _e (A)	25A、32A、40A、50A、63A、80A、100A、125A
Number of Poles	1P、2P、3P、4P
Rated Short-Time Withstand Current I _{cw}	12I _e (t=1s)
Rated Short-Circuit Making Capacity I _{cm}	20I _e (t=0.05s)
Rated Impulse Withstand Voltage U _{imp}	(1.2 / 50μs、2000m) 4000V
Rated Making and Breaking Capacity	3I _e 、1.05U _e 、cosφ=0.65
Mechanical Life	≥8500
Electrical Life	≥1500
Standard	IEC60947-3, GB/T 14048.3
Certification	CCC

Conductor requirements and cross section

Copper cross-section(mm ²)	Rated current I _n (A)
6	32A
10	40A
10	50A
16	63A
25	80A
35	100A
50	125A

Dimensions(mm)

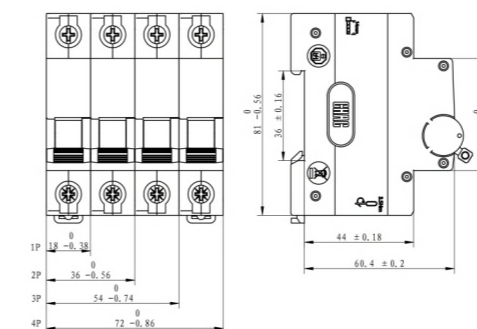

Ordering Specification

Please specify the following when ordering:

- 1.Product Model: PXD6-125
 - 2.Number of Poles: 1P, 2P, 3P, 4P
 - 3.Rated Current : [e.g., C/16A]
 - Rated Current (I_n): 25A、32A、40A、50A、63A、80A、100A、125A
 - 4.Quantity: [e.g., 100 pcs]
- Ordering Example:
PXD6-125 2P C/125A 100 pcs

PXB6-OF Auxiliary Contact



Product Features

- Remote Signal Indication - Mounts with the circuit breaker to provide remote ON/OFF status signals.
- AC/DC Compatibility - Suitable for AC 230V or DC 110V circuits.
- High Mechanical Life - Mechanical life $\geq 10,000$ operations for durability.
- Plug-and-Play - Easy installation with seamless integration into CQB6 breakers.

Type designation

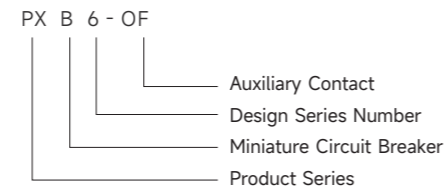

Technical Specifications

Parameter		
AC-15	Rated Operational Voltage	AC 230V 50Hz
	Rated operating current	6A
DC-13	Rated Operational Voltage	DC110V
	Rated operating current	1A
Mechanical Life	10000	
Standards	IEC 60947-5-1	

Conductor requirements and cross section

Copper cross-section(mm ²)
0.5-2.5

Dimensions(mm)

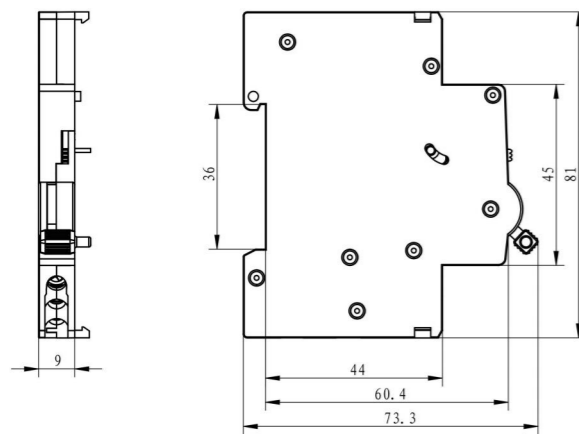

PXB6-SD Alarm Contact



Product Features

- Fault Alarm Function - Sends remote alarm signals upon circuit breaker fault tripping.
- Remote Indication - Provides visual or electrical alerts for easy monitoring.
- High Compatibility - Designed specifically for CQB6 series to ensure compatibility.
- Long-Life Design - Long mechanical life suitable for frequent use scenarios.

Type designation

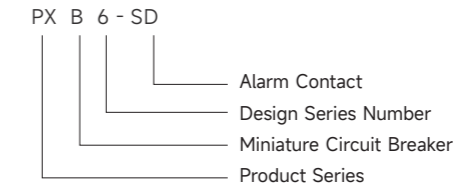

Technical Specifications

Parameter		
AC-15	Rated Operational Voltage	AC 230V 50Hz
	Rated operating current	6A
DC-13	Rated Operational Voltage	DC110V
	Rated operating current	1A
Mechanical Life	10000	
Standards	IEC 60947-5-1	

Conductor requirements and cross section

Copper cross-section(mm ²)
0.5-2.5

Dimensions(mm)

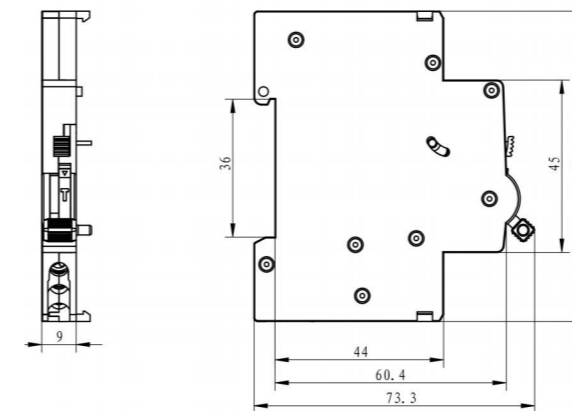

Ordering Specification

Please specify the following when ordering:

- Product Model: PXB6-SD
- Quantity: [e.g.: 100 pcs]

Ordering Example:

PXB6-SD 100 pcs

PXB6-MV MN

Over/Under Voltage Release



Product Features

- Remote Tripping Control - Enables remote breaker tripping by applying voltage.
- Fast Response - Quick action ensures timely protection.
- Wide Voltage Range - Broad operating voltage range for various environments.
- Safety System Integration - Suitable for automated safety control systems.

Type designation

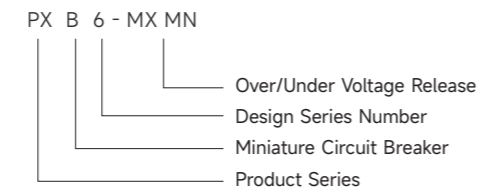

Technical Specifications

Parameter	
Rated Operational Voltage (V)	AC 230V 50Hz
Rated Insulation Voltage (V)	415V
Operating Characteristics	Maintains long-term circuit breaker operation at voltages between 175V - 255V.
	Trips at voltages $\geq 265\pm 10V$ (Over-Voltage) Trips at voltages $\leq 165\pm 10V$ (Under-Voltage)
Electrical life	4,000
Standards	IEC 60947-5-1

Conductor requirements and cross section

Copper cross-section(mm ²)
0.5-2.5

Dimensions(mm)

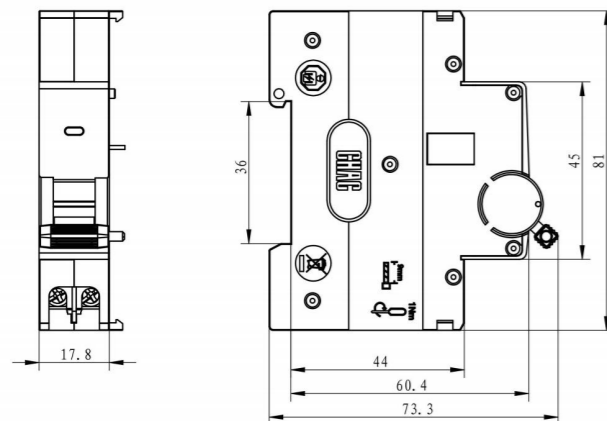

PXB6-MX

Shunt Release



Product Features

- Over-Voltage Protection - Monitors voltage and trips automatically when over-voltage ($\geq 265V\pm 10V$).
- Under-Voltage Protection - Trips automatically under under-voltage ($\leq 165V\pm 10V$) to protect equipment.
- Auto-Recovery - Automatically resets when voltage normalizes, reducing manual intervention.
- Wide Operating Range - Normal operating voltage range of 175V-255V for high stability.

Type designation

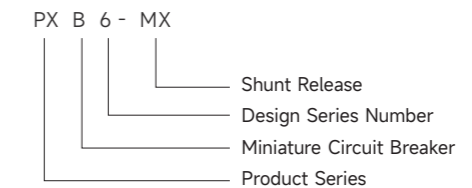

Technical Specifications

Parameter	
Rated operational voltage U_s	AC 230V50Hz
Rated insulation voltage U_i	415V
Operating characteristics	The release unit can operate reliably within (70% to 110%) of U_s
Electrical life	4000 operations
Complies with standards	IEC60947-5-1

Conductor requirements and cross section

Copper cross-section(mm ²)
0.5-2.5

Dimensions(mm)

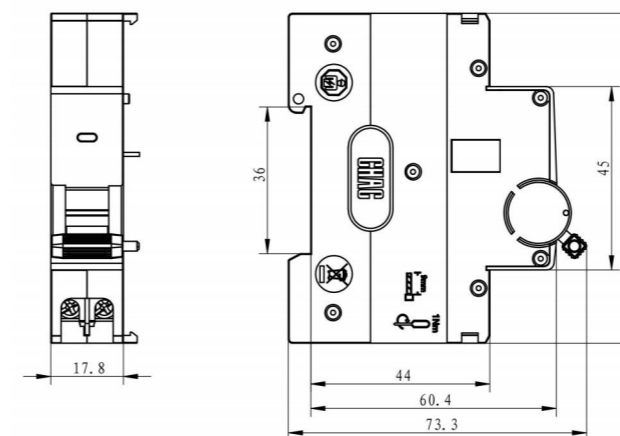

Ordering Specification

Please specify the following when ordering:

- Product Model: PXB6-MX
- Quantity: [e.g.: 100 pcs]

Ordering Example:

PXB6-MX 100 pcs

PXB9-63

Miniature Circuit Breaker



Product Features

- High interruption rating capabilities
- Overload & short circuit protection
- Positive isolation
- Suitable for industrial, commercial, high-rise and civil residences circuit protection

Type designation

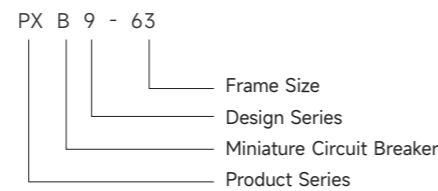

Technical Specifications

Parameter	
Rated voltage	230V / 400V
Rated impulse withstand voltage (Uimp)	4000 V
Rated current	6A, 10A, 13A, 16A, 20A, 25A, 32A, 40A, 50A, 63A
Rated frequency	50 Hz / 60 Hz
Number of poles	1P, 2P, 3P, 4P
Rated breaking capacity (Icn/lcs)	6000 A
Mechanical life	10,000 operations
Electrical life	6,000 operations
Tripping characteristics	B, C, D
Pollution degree	2
Degree of protection	IP20
Standards	EN/IEC 60898-1, GB/T 10963.1
Tightening torque	3.5 N·m

Tripping characteristics (Reference temp.30°C)

Item	Tripping Curve	Test current I _n (A)	Initial Status	Time limit for tripping or non-tripping	Expected result	Remarks
a	B, C, D	1.13I _n	Cold	t ≤ 1h	Non-tripping	Current smoothly rises to specified value within 5s
b	B, C, D	1.45I _n	Following item a test	t < 1h	Tripping	
c	B, C, D	2.55I _n	Cold	1s < t < 60s (I _n ≤ 32A) 1s < t < 120s (I _n > 32A)	Tripping	
d	B	3I _n	Cold	t ≤ 0.1s	Non-tripping	Switch on the power supply by closing the auxiliary switch
	C	5I _n				
e	B	5I _n	Cold	t < 0.1s	Tripping	Switch on the power supply by closing the auxiliary switch
	C	10I _n				
	D	20I _n				

Note: The term "cold" means that the test is carried out at a reference calibration temperature without load before the test.

Tripping Curve

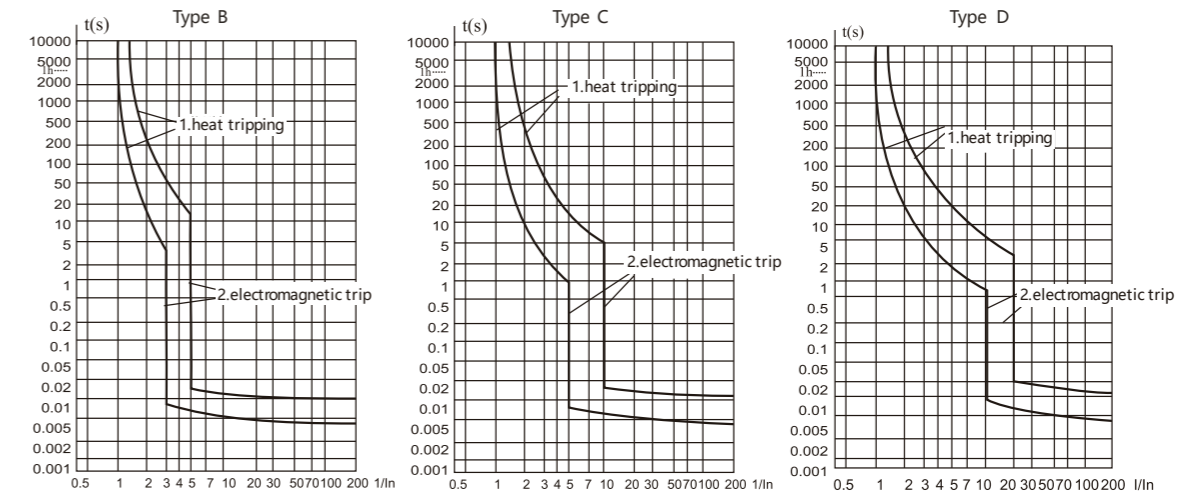

Conductor requirements and cross section

Copper cross-section(mm ²)	Rated current I _n (A)
1	I _n ≤ 6
1.5	6 < I _n ≤ 13
2.5	13 < I _n ≤ 20
4	20 < I _n ≤ 25
6	25 < I _n ≤ 32
10	32 < I _n ≤ 50
16	50 < I _n ≤ 63

Dimensions(mm)

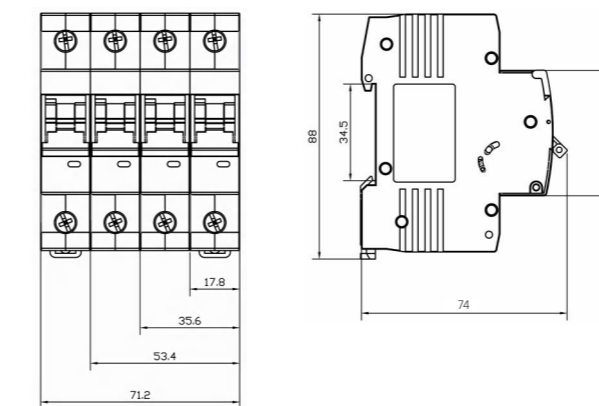

Ordering Specification

Please specify the following when ordering:

- 1.Product Model: PXB9-63
 - 2.Number of Poles: 1P, 2P, 3P, 4P
 - 3.Rated Current & Tripping Curve: [e.g.: C/16A]
 - Tripping Curve: B, C, D
 - Rated Current (I_n): 6A, 10A, 13A, 16A, 20A, 25A, 32A, 40A, 50A, 63A
 - 4.Quantity: [e.g.: 100 pcs]
- Ordering Example:
PXB9-63 2P C/16A 100 pcs

PXB9N-32

Miniature Circuit Breaker



Product Features

- Compact structure and robust design
- Low power consumption
- Easy DIN-Rail extraction
- Overload & short circuit protection
- Suitable for industrial, commercial, high-rise and civil residences circuit protection

Type designation

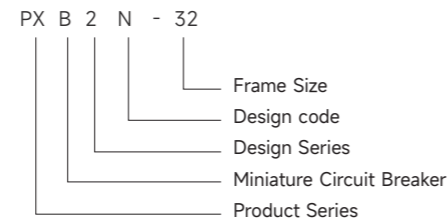

Technical Specifications

Parameter	
Rated voltage	230V~
Rated impulse withstand voltage (Uimp)	4000 V
Rated current	6A, 10A, 13A, 16A, 20A, 25A, 32A
Rated frequency	50 Hz / 60 Hz
Number of poles	1P+N
Rated breaking capacity (Icn/Ics)	6000 A
Mechanical life	10,000 operations
Electrical life	4,000 operations
Tripping characteristics	B, C, D
Pollution degree	2
Degree of protection	IP20
Standards	EN/IEC 60898-1, GB/T 10963.1
Tightening torque	2 N·m

Tripping characteristics (Reference temp.30°C)

Item	Tripping Curve	Test current I _n (A)	Initial Status	Time limit for tripping or non-tripping	Expected result	Remarks
a	B, C, D	1.13I _n	Cold	t ≤ 1h	Non-tripping	Current smoothly rises to specified value within 5s
b	B, C, D	1.45I _n	Following item a test	t < 1h	Tripping	
c	B, C, D	2.55I _n	Cold	1s < t < 60s (I _n ≤ 32A) 1s < t < 120s (I _n > 32A)	Tripping	
d	B	3I _n	Cold	t ≤ 0.1s	Non-tripping	Switch on the power supply by closing the auxiliary switch
	C	5I _n				
	D	10I _n				
e	B	5I _n	Cold	t < 0.1s	Tripping	Switch on the power supply by closing the auxiliary switch
	C	10I _n				
	D	20I _n				

Note: The term "cold" means that the test is carried out at a reference calibration temperature without load before the test.

Tripping curves

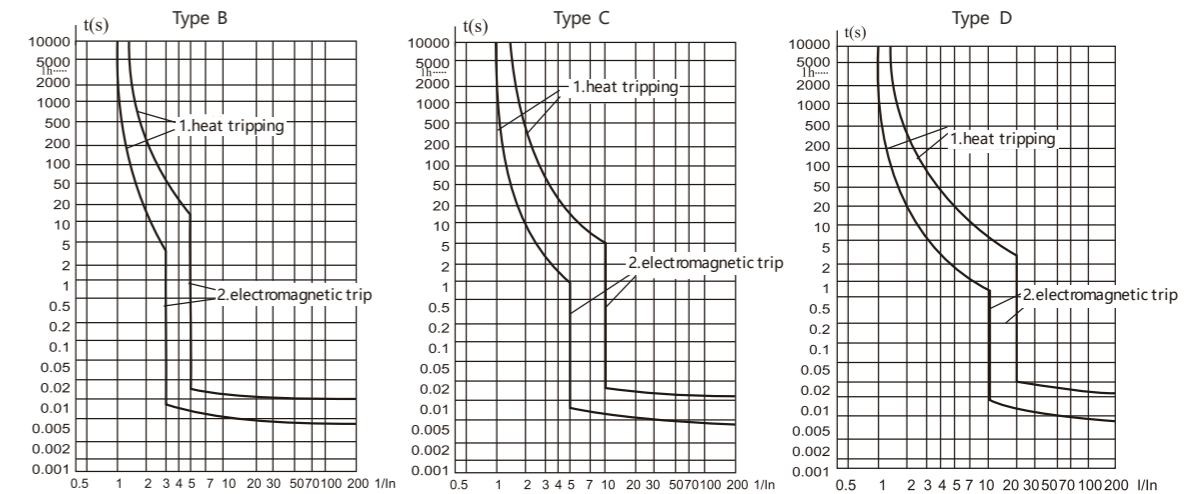

Conductor requirements and cross section

Copper cross-section(mm ²)	Rated current I _n (A)
1	I _n ≤ 6
1.5	6 < I _n ≤ 13
2.5	13 < I _n ≤ 20
4	20 < I _n ≤ 25
6	25 < I _n ≤ 32

Dimensions(mm)

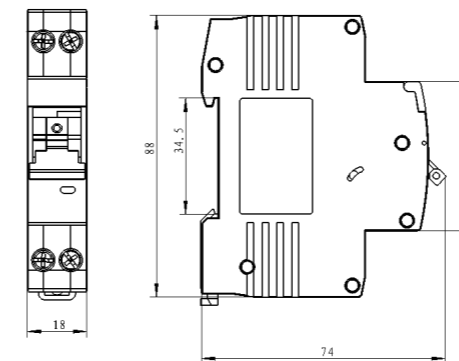

Ordering Specification

Please specify the following when ordering:

- 1.Product Model: PXB9N-32
- 2.Number of Poles: 1P+N
- 3.Rated Current & Tripping Curve: [e.g.: C/16A]
 - Tripping Curve: B, C, D
 - Rated Current (I_n): 6A, 10A, 13A, 16A, 20A, 25A, 32A

4.Quantity: [e.g.: 100 pcs]

Ordering Example:

PXB9N-32 1P+N C/16A 100 pcs

PXB9L-40

Residual Current Operated Circuit Breaker (Electromagnetic)

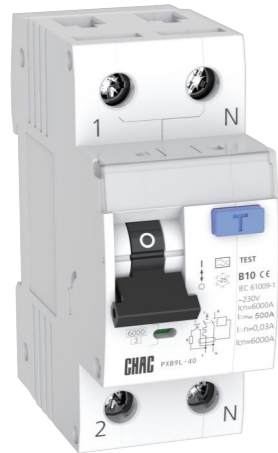

Product Features

- Provides ground fault/leakage current, short circuit, overload protection and isolation.
- Provides additional protection against direct human contact.
- Effectively prevents electrical equipment insulation failure.
- Comprehensive protection for residential and commercial power distribution systems.

Type designation

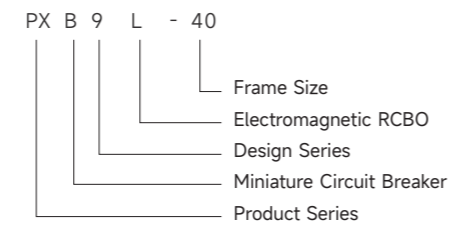

Technical Specifications

Parameter	
Rated voltage	230 V
Rated current	6, 10, 13, 16, 20, 25, 32, 40 A
Rated frequency	50 Hz
Number of poles	1P+N
Rated breaking capacity (Icn/Ics)	6000 A
Mechanical life	10,000 operations
Electrical life	4,000 operations
Tripping characteristics	B, C, D
Type of residual current	AC, A
Rated residual operating current (IΔn)	30 mA
Rated residual making & breaking capacity (IΔm)	500 A
Pollution degree	2
Degree of protection	IP20
Standards	EN/IEC 61009-1, GB/T 16917.1
Tightening torque	3.5 N·m

Tripping characteristics (Reference temp.30°C)

Item	Tripping Curve	Test current I _n (A)	Initial Status	Time limit for tripping or non-tripping	Expected result	Remarks
a	B, C, D	1.13I _n	Cold	t ≤ 1h	Non-tripping	Current smoothly rises to specified value within 5s
b	B, C, D	1.45I _n	Following item a test	t < 1h	Tripping	
c	B, C, D	2.55I _n	Cold	1s < t < 60s (I _n ≤ 32A) 1s < t < 120s (I _n > 32A)	Tripping	
d	B	3I _n	Cold	t ≤ 0.1s	Non-tripping	Switch on the power supply by closing the auxiliary switch
	C	5I _n				
e	D	10I _n	Cold	t < 0.1s	Tripping	Switch on the power supply by closing the auxiliary switch
	B	5I _n				
	C	10I _n				
	D	20I _n				

Note: The term "cold" means that the test is carried out at a reference calibration temperature without load before the test.

Tripping curves

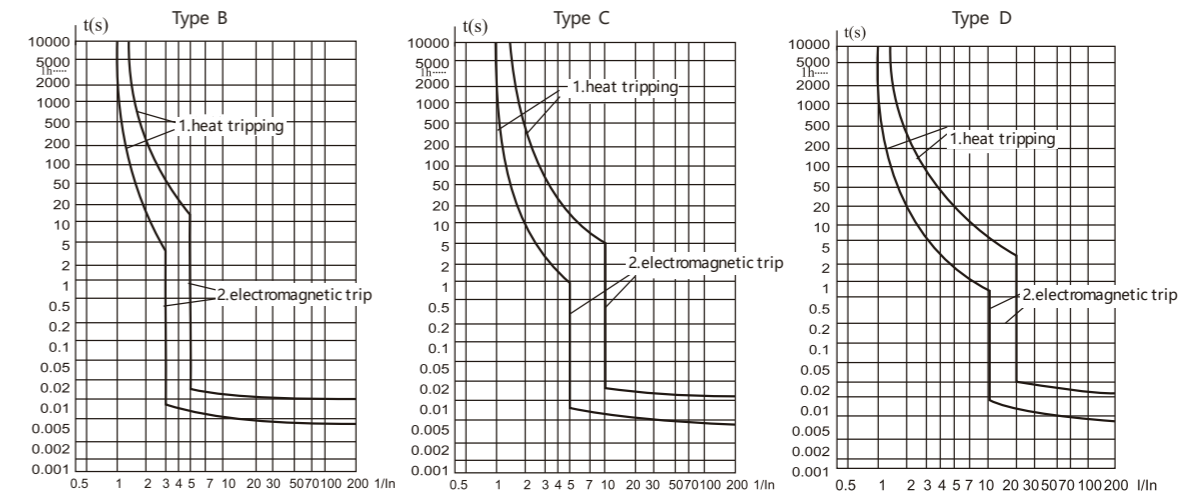

Conductor requirements and cross section

Copper cross-section(mm ²)	Rated current I _n (A)
1	I _n ≤ 6
1.5	6 < I _n ≤ 13
2.5	13 < I _n ≤ 20
4	20 < I _n ≤ 25
6	25 < I _n ≤ 32
10	32 < I _n ≤ 40

Dimensions(mm)

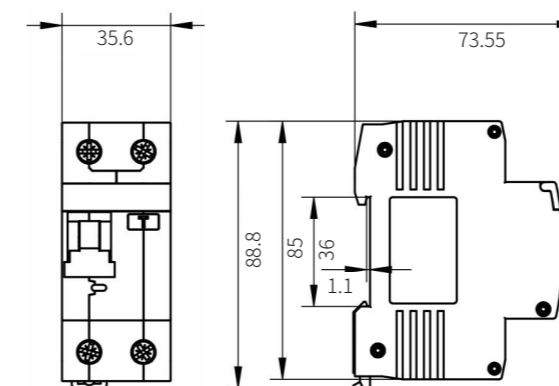

Ordering Specification

Please specify the following when ordering:

- 1.Product Model: PXB9L-40
- 2.Number of Poles: 1P+N
- 3.Rated Current & Tripping Curve: [e.g.: C/16A]
 - Tripping Curve: B, C, D
 - Rated Current (I_n): 6A, 10A, 13A, 16A, 20A, 25A, 32A, 40A
- 4.Type of Residual Current: AC, A
- 5.Rated Residual Operating Current (I_{Δn}): [e.g.: 30mA]
 - Available Options: 30mA, 100mA, 300mA
- 6.Quantity: [e.g.: 100 pcs]

Ordering Example:

PXB9L-40 1P+N C/16A AC 30mA 100 pcs

PXL9-63

Residual Current Circuit Breaker (Electromagnetic)



Product Features

- Used in housing, tertiary sector and industry.
- Control electric circuits.
- Protect people against indirect contacts and additional protection against direct contacts.
- Protect installations against fire hazard due to insulation faults.
- Wide variety of rated tripping currents.

Type designation

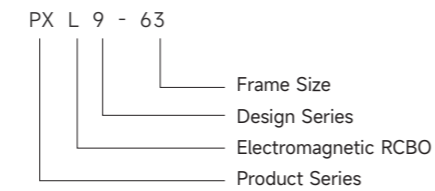

Technical Specifications

Parameter	
Rated voltage U_e	230V/400V
Rated current(A)	6、10、16、20、25、32、40、50、63
Rated insulation voltage(U_i)	500V
Rated frequency	50Hz/60Hz
Number of poles	2P、4P
Rated limited short-circuit current $I_{nc}(A)$	6000
Rated limited residual short-circuit current $I_{\Delta c}(A)$	6000
Mechanical&Electrical life	4000
Rated residual operating current $I_{\Delta n}(mA)$	30、100、300
Pollution degree	2
Protection degree	IP20
Standards	EN/IEC61008-1、GB/T16916.1
Tighten torque(Nm)	2.5
Rated impulse withstand voltage(U_{imp})	4000V
Type of residual current	AC、A、B、S、G
Rated making&breaking capacity $I_m(A)$	500A or $10I_n$ (Take the maximumvalue)
Rated residual making&breaking capacity $I_{\Delta m}(A)$	500A or $10I_n$ (Take the maximumvalue)

Dimensions(mm)

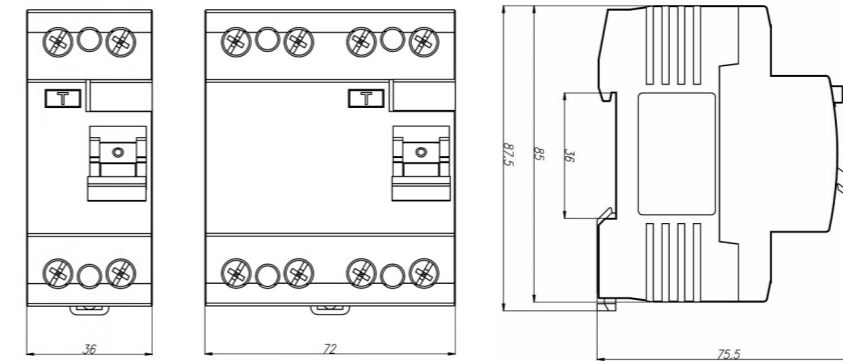

Ordering Specification

Please specify the following when ordering:

- 1.Product Model: PXL9-63
- 2.Number of Poles: 2P, 4P
- 3.Rated Current (I_n): [e.g.: 32A]
 - Available Currents: 6A, 10A, 16A, 20A, 25A, 32A, 40A, 50A, 63A
- 4.Type of Residual Current: AC, A, B, S, G
- 5.Rated Residual Operating Current ($I_{\Delta n}$): [e.g.: 30mA]
 - Available Options: 30mA, 100mA, 300mA
- 6.Quantity: [e.g.: 100 pcs]

Ordering Example:

PXL9-63 2P 32A AC 30mA 100 pcs

CQB7DC-63

DC Miniature Circuit Breaker



Product Features

- DC Specialized Design
Specifically designed for DC circuits with rated working voltage up to 1000V, suitable for various DC power distribution systems
- High Breaking Capacity
Rated short-circuit breaking capacity of 6kA, providing reliable overload and short-circuit protection
- Communication Industry Application
Specially suitable for power distribution systems in communication industry main cabinets, power cabinets, distribution cabinets, and outdoor cabinets

Type designation

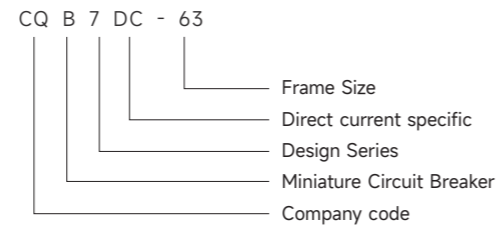

Tripping curves

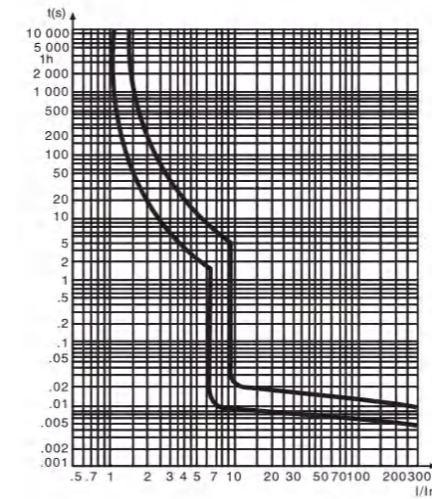

Dimensions(mm)

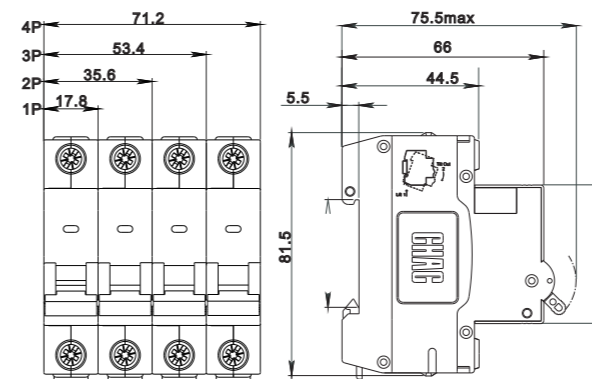

Ordering Specification

Please specify the following when ordering:

- 1.Product Model: CQB7DC-63
 - 2.Number of Poles: 1P, 2P, 3P, 4P
 - 3.Rated Current & Tripping Curve: [e.g.: C/32A]
 - Tripping Curve: B, C, D
 - Available Currents: 6A, 10A, 13A, 16A, 20A, 25A, 32A, 40A, 50A, 63A
 - 4.Quantity: [e.g.: 100 pcs]
- Ordering Example:
CQB7DC-63 2P C/32A 100 pcs

Technical Specifications

Parameter	
Rated voltage	1P, 2P, 3P, 4P
Rated current	6A, 10A, 13A, 16A, 20A, 25A, 32A, 40A, 50A, 63A
Rated insulation voltage	DC 1000 V
Ultimate breaking capacity (Icu)	6 kA
Operational breaking capacity (Ics)	6 kA
Tripping curves	Type B (4In±20%), Type C (8In±20%)
Mechanical life	10,000 operations
Electrical life	1,500 operations
Wiring capacity	≤ 25 mm ²
Tightening torque	3.0 N·m
Degree of protection	IP20
Standards	GB/T 14048.2
Certification	CCC

Tripping characteristics (Reference temp.30°C)

Item	Tripping Curve	Test current In(A)	Initial Status	Time limit for tripping or non-tripping	Expected result	Remarks
a	C	1.05In	Cold	t ≤ 1h	Non-tripping	
b	C	1.3In	Following item a test	t < 1h	Tripping	Current smoothly rises to specified value within 5s
c	C	2.55In	Cold	1s < t < 60s (In ≤ 32A) 1s < t < 120s (In > 32A)	Tripping	
d	C	5In	Cold	t ≤ 0.1s	Non-tripping	Switch on the power supply by closing the auxiliary switch
e	C	10In	Cold	t < 0.1s	Tripping	Switch on the power supply by closing the auxiliary switch

Note: The term "cold" means that the test is carried out at a reference calibration temperature without load before the test.

CQB7ZNM-80

Miniature Circuit Breaker



Product Features

- Smart Remote Control
Mobile control via Smart Life/Tuya Smart App for remote circuit management
- Precision Power Monitoring
0.5S class metering accuracy for real-time voltage, current, and power monitoring
- Multi-Protection Function
8 safety protections including overload, short-circuit, leakage, over/under voltage, and over-temperature
- Intelligent Timing Setting
Daily/weekly/monthly timer settings for automated power management

Type designation

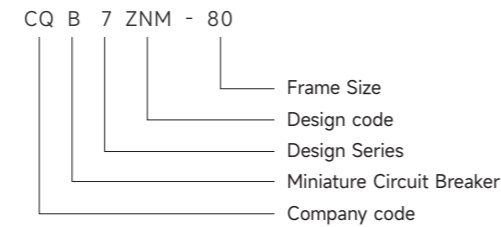

Tripping curves

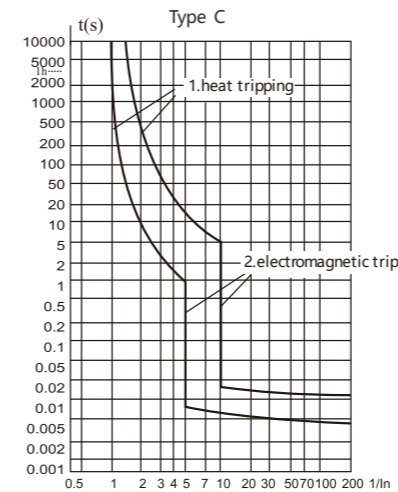

Technical Specifications

Parameter	
Number of poles	1P+N
Communication mode	Wi-Fi
Degree of protection (IP)	IP20
Application for mobile devices	Smart Life/Tuya Smart
Rated current I _n	32A/ 40A/63A/ 80A
Types of RCD	AC type
Tripping characteristic	C
Frequency	50 Hz
Rated voltage	1P+N: 230 /240V
Complies with standard	IEC 61009-1、 IEC 60898-1
Rated short circuit breaking capacity I _{cn}	6 kA
Mechanical service life	10000 Times
Electrical service life	6000 Times
Dimension	1P+N (L*H*W:90*72*53 mm)

Tripping characteristics (Reference temp.30°C)

Item	Test current I _n (A)	Initial Status	Time limit for tripping or non-tripping	Expected result	Remarks
a	1.13I _n	Cold	t ≤ 1h (I _n ≤ 63A) t ≤ 2h (I _n > 63A)	Non-tripping	
b	1.45I _n	Following item a test	t < 1h (I _n ≤ 63A) t < 2h (I _n > 63A)	Tripping	Current smoothly rises to specified value within 5s
c	2.55I _n	Cold	1s < t < 120s	Tripping	
d	5I _n	Cold	t ≤ 0.1s	Non-tripping	Switch on the power supply by closing the auxiliary switch
e	10I _n	Cold	t < 0.1s	Tripping	Switch on the power supply by closing the auxiliary switch

Note: The term "cold" means that the test is carried out at a reference calibration temperature without load before the test.

Dimensions(mm)

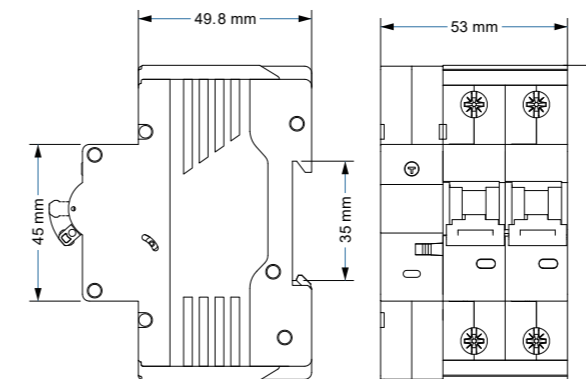

Ordering Specification

Please specify the following when ordering:

- 1.Product Model: CQB7ZNM-80
- 2.Number of Poles: 1P+N
- 3.Rated Current: [e.g.: 32A]
 - Available Currents: 32A, 40A, 63A, 80A
- 4.Quantity: [e.g.: 100 pcs]

Ordering Example:

CQB7ZNM-80 1P+N Wi-Fi 32A AC type 100 pcs

CQB71R-100

External Circuit-Breaker For Electricity Meters



Product Features

- Designed for electricity meters
- Enables remote automatic control
- High breaking capacity
- Overload & short circuit protection

Type designation

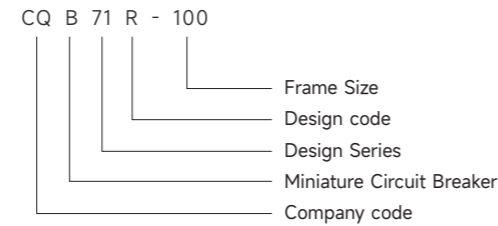

Technical Specifications

Parameter	
Rated voltage (V)	230V
Rated current (A)	40, 63, 80, 100
Rated impulse withstand voltage Uimp(V)	6000V
Rated frequency	50Hz / 60Hz
Polar number	1P+N
Rated short-circuit capacity Icn(A)	6kA
Operating short-circuit capacity Ics(A)	6kA
Mechanical and electrical life (times)	Mechanical life ≥ 10,000, electrical life ≥ 6,000
Instantaneous tripping type	B, C, D
Tightening torque (N·m)	2.5
Automatic closing time (tc)	t ≤ 3s
Automatic opening time (td)	t ≤ 2s
Pollution level	Level 2
Protection grade	IP20
Installation category	III
Meet the standards	IEC60898-1, GB/T 10963-1
Certification	CCC

Tripping characteristics (Reference temperature 30°C)

Item	Tripping Curve	Test current In(A)	Initial Status	Time limit for tripping or non-tripping	Expected result	Remarks
a	B, C, D	1.13In	Cold	t ≤ 1h	Non-tripping	Current smoothly rises to specified value within 5s
b	B, C, D	1.45In	Following item a test	t < 1h	Tripping	
c	B, C, D	2.55In	Cold	1s < t < 60s (In ≤ 32A) 1s < t < 120s (In > 32A)	Tripping	
d	B	3In	Cold	t ≤ 0.1s	Non-tripping	Switch on the power supply by closing the auxiliary switch
	C	5In				
	D	10In				
e	B	5In	Cold	t < 0.1s	Tripping	Switch on the power supply by closing the auxiliary switch
	C	10In				
	D	20In				

Note: The term "cold" means that the test is carried out at a reference calibration temperature without load before the test.

Tripping curves

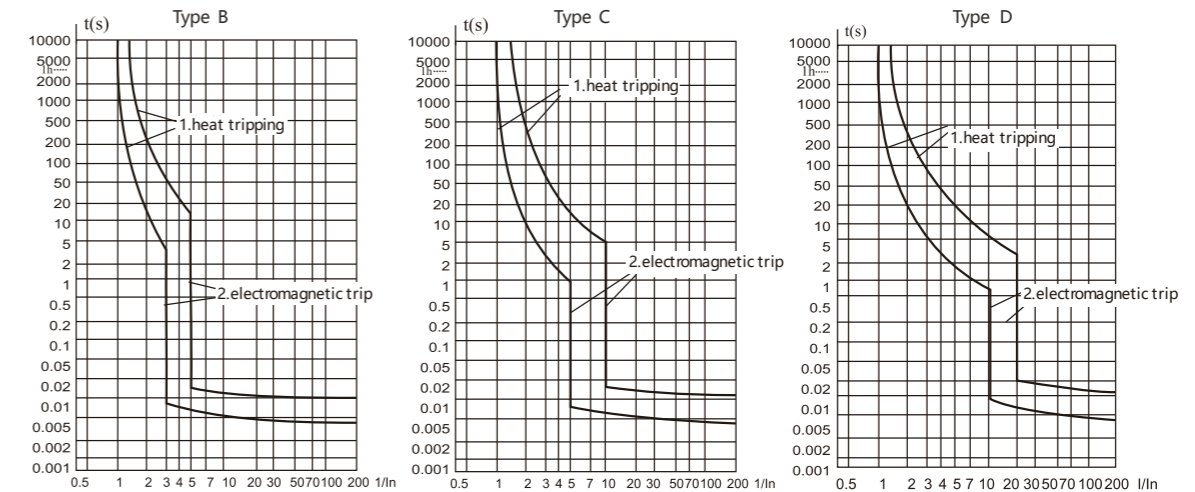

Conductor requirements and cross section

Copper cross-section(mm ²)	Rated current In(A)
10	32 < In ≤ 50
16	50 < In ≤ 63
25	63 < In ≤ 80
35	80 < In ≤ 100
50	100 < In ≤ 125

Dimensions(mm)

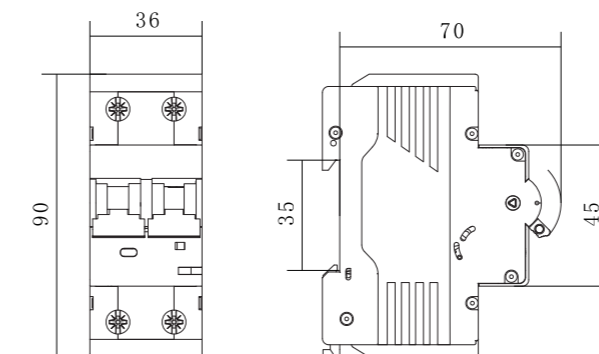

Ordering Specification

Please specify the following when ordering:

- Product Model: CQB71R-100
- Number of Poles: 1P+N
- Rated Current & Tripping Curve: [e.g.: C/63A]
 - Tripping Curve: B, C, D
 - Rated Current: 40A, 63A, 80A, 100A
- Quantity: [e.g.: 100 pcs]

Ordering Example:

CQB71R-100 1P+N C/63A 100 pcs

CQB7R-125

Prepayment Meter External Circuit Breaker



Product Features

- Intelligent automatic control
- Designed for prepayment meters
- Automatic tripping and closing
- Overload & short circuit protection

Type designation

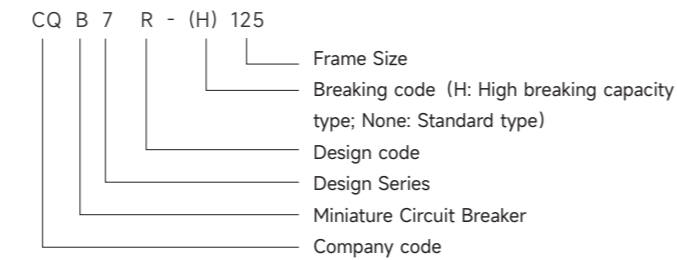

Technical Specifications

Parameter	
Rated voltage (V)	30V~(2P), 400V~ (4P)
Rated current (A)	40, 50, 63, 80, 100, 125
Rated impulse withstand voltage Uimp(V)	6000V
Rated frequency	50Hz / 60Hz
Polar number	2P, 4P
Rated short-circuit capacity Icn(A)	6kA, 10kA (high breaking score)
Operating short-circuit capacity Ics(A)	6kA, 7.5kA (high break type)
Mechanical and electrical life (times)	Mechanical life ≥ 10,000, electrical life ≥ 6,000
Instantaneous tripping type	B, C, D
Tightening torque (N·m)	3.5
Automatic closing time (tc)	t ≤ 3s
Automatic opening time (td)	t ≤ 2s
Pollution level	Level 2
Protection grade	IP20
Installation category	III
Meet the standards	IEC60898-1, GB10963-1
Certification	CCC

Tripping characteristics (Reference temperature 30°C)

Item	Tripping Curve	Test current In(A)	Initial Status	Time limit for tripping or non-tripping	Expected result	Remarks
a	B, C, D	1.13In	Cold	t ≤ 1h	Non-tripping	Current smoothly rises to specified value within 5s
b	B, C, D	1.45In	Following item a test	t < 1h	Tripping	
c	B, C, D	2.55In	Cold	1s < t < 60s (In ≤ 32A) 1s < t < 120s (In > 32A)	Tripping	
d	B	3In	Cold	t ≤ 0.1s	Non-tripping	Switch on the power supply by closing the auxiliary switch
	C	5In				
	D	10In				
e	B	5In	Cold	t < 0.1s	Tripping	Switch on the power supply by closing the auxiliary switch
	C	10In				
	D	20In				

Note: The term "cold" means that the test is carried out at a reference calibration temperature without load before the test.

Tripping curves

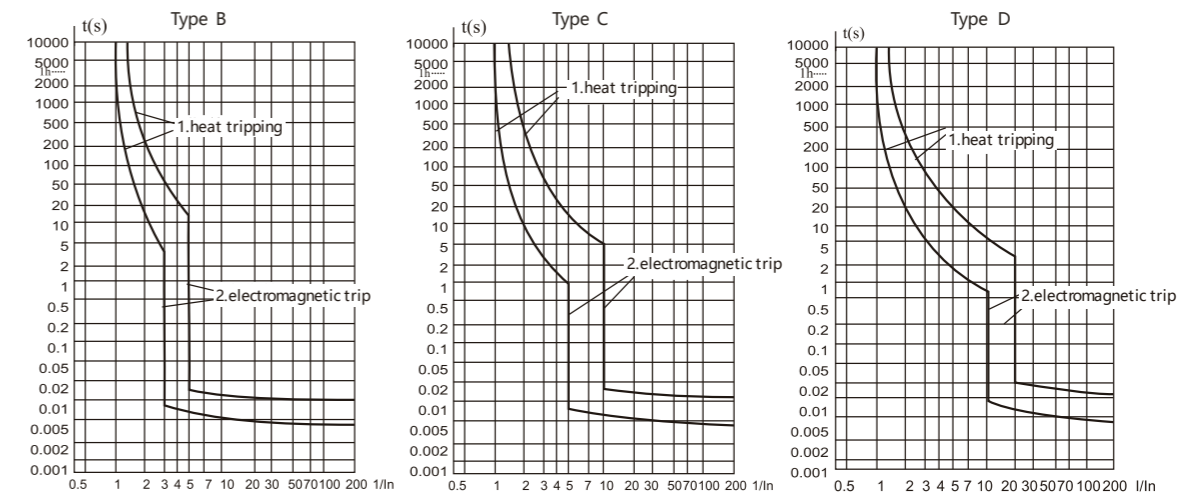

Conductor requirements and cross section

Copper cross-section(mm ²)	Rated current In(A)
10	32 < In ≤ 50
16	50 < In ≤ 63
25	63 < In ≤ 80
35	80 < In ≤ 100
50	100 < In ≤ 125

Dimensions(mm)

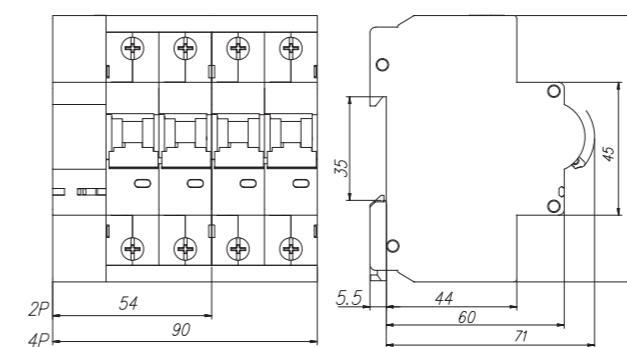

Ordering Specification

Please specify the following when ordering:

- 1.Product Model: CQB7R-125
- 2.Number of Poles: 2P, 4P
- 3.Rated Current & Tripping Curve: [e.g.: C/100A]
 - Tripping Curve: B, C, D
 - Rated Current: 40A, 50A, 63A, 80A, 100A, 125A
- 4.Quantity: [e.g.: 100 pcs]

Ordering Example:

CQB7R-125 2P C/100A 100 pcs

PXB2-63

Miniature Circuit Breaker



Product Features

- Comprehensive & Versatile**
Integrates isolation, overload, and short-circuit protection. Suitable for a wide range of applications (commercial/industrial/residential)
- Flexible Configuration**
Offers three instantaneous tripping characteristics (Types B, C, D), multiple poles (1P, 2P, 3P, 4P), and a wide range of rated currents from 1A to 63A to meet diverse circuit requirements.
- Safety Certification**
Complies with international standards IEC60898-1 and GB/T10963.1, and holds China Compulsory Certification (CCC).

Type designation

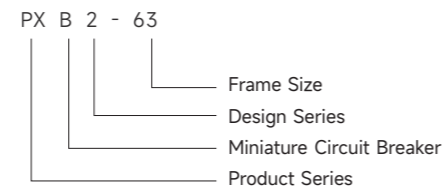

Tripping curves

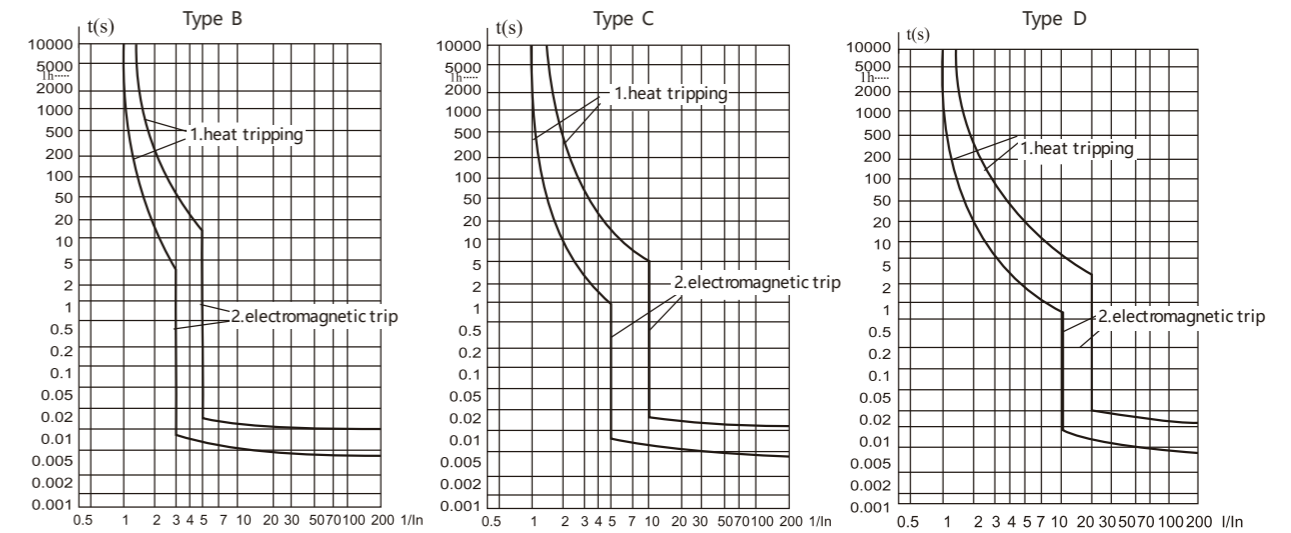

Technical Specifications

Parameter	
Rated Insulation Voltage	500V
Rated Impulse Withstand Voltage	4000V
Rated Current (A)	6, 10, 16, 20, 25, 32, 40, 50, 63
Rated Frequency	50Hz / 60Hz
Number of Poles	1P, 2P, 3P, 4P
Rated Short-Circuit Capacity Icn (A)	4500A
Service Short-Circuit Capacity Ics (A)	4500A
Mechanical and Electrical Endurance (cycles)	Mechanical≥10000, Electrical≥10000
Instantaneous Tripping Types	B, C, D
Grip Distance	45mm
Protection Degree	IP20
Standards Compliance	IEC60898-1, GB/ T10963.1
Certification	CCC

Conductor requirements and cross section

Copper cross-section(mm ²)	Rated current In(A)
1	In≤6
1.5	6 < In≤13
2.5	13 < In≤20
4	20 < In≤25
6	25 < In≤32
10	32 < In≤50
16	50 < In≤63

Dimensions(mm)

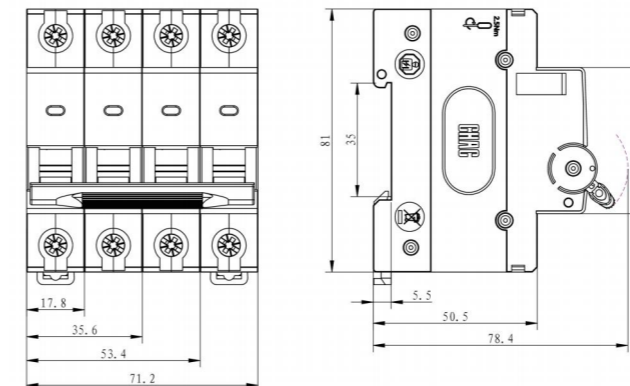

Ordering Specification

- Product Model: PXB2-63
 - Number of Poles: 1P, 2P, 3P, 4P
 - Rated Current & Tripping Curve: [e.g.: C/32A]
 - Tripping Curve: B, C, D
 - Rated Current (In): 6A, 10A, 16A, 20A, 25A, 32A, 40A, 50A, 63A
 - Quantity: [e.g.: 100 pcs]
- Ordering Example:
PXB2-63 2P C/32A 100 pcs

Tripping characteristics (Reference temperature 30°C)

Item	Tripping Curve	Test current In(A)	Initial Status	Time limit for tripping or non-tripping	Expected result	Remarks
a	B, C, D	1.13In	Cold	t ≤ 1h	Non-tripping	Current smoothly rises to specified value within 5s
b	B, C, D	1.45In	Following item a test	t < 1h	Tripping	
c	B, C, D	2.55In	Cold	1s < t < 60s (In ≤ 32A) 1s < t < 120s (In > 32A)	Tripping	
d	B	3In	Cold	t ≤ 0.1s	Non-tripping	Switch on the power supply by closing the auxiliary switch
	C	5In				
e	D	10In	Cold	t < 0.1s	Tripping	Switch on the power supply by closing the auxiliary switch
	B	5In				
	C	10In				
	D	20In				

Note: The term "cold" means that the test is carried out at a reference calibration temperature without load before the test.

PXB2Ln-63

Residual Current Circuit Breaker with Overcurrent Protection - Electronic Type



Product Features

- Earth Leakage Protection
30/50/100/300mA sensitivity options provide personal protection against electric shock
- Dual Protection Function
Combines overload/short-circuit protection with earth leakage protection
- Fast Response
≤0.1s tripping time for quick fault circuit interruption
- Flexible Configurations
1P+N, 2P, 3P, 3P+N and 4P versions available

Type designation

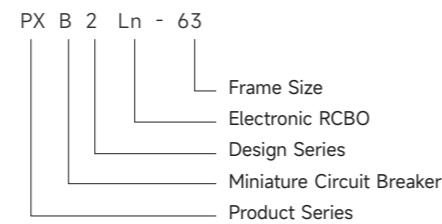

Technical Specifications

Parameter	
Rated Current (In)	6A, 10A, 16A, 20A, 25A, 32A, 40A, 50A, 63A
Rated Voltage	230V~
Rated Frequency	50/60Hz
Rated Breaking Capacity	6kA
Tripping Type	Thermal-magnetic (for overload and short-circuit)
Residual Current Operating Characteristic	AC, A
Rated Residual Operating Current ((IΔn)	30mA
Rated Residual Non-Operating Current ((IΔno)	15mA
Instantaneous Tripping Type	B, C
Number of Poles	1P+N
Rated Impulse Withstand Voltage (Uimp)	4kV (1.2/50 μs wave)
Power Frequency Withstand Voltage Test	2kV for 1 minute
Thermal Tripping Characteristic	(1.13-1.45) x In
Magnetic Tripping Characteristic	B: (3-5) x In, C: (5-10) x In
Electrical Endurance	6,000 cycles
Mechanical Endurance	10,000 cycles
Contact Position Indicator	Yes
Degree of Protection	IP20
Ambient Temperature	-25°C to +40°C, max. humidity 95%
Maximum Cable Terminal Size	16mm ²
Maximum Tightening Torque	2.5 N.m
Mounting Method	Mounts on 35mm DIN rail
Standard	IEC/EN 61009-1

Tripping curves

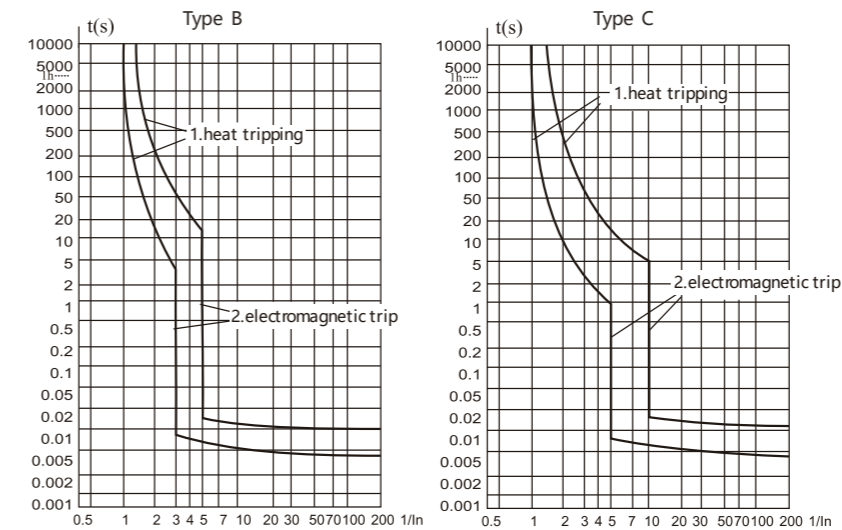

Conductor requirements and cross section

Copper cross-section(mm ²)	Rated current In(A)
1	In≤6
1.5	6 < In≤13
2.5	13 < In≤20
4	20 < In≤25
6	25 < In≤32
10	32 < In≤50
16	50 < In≤63

Dimensions(mm)

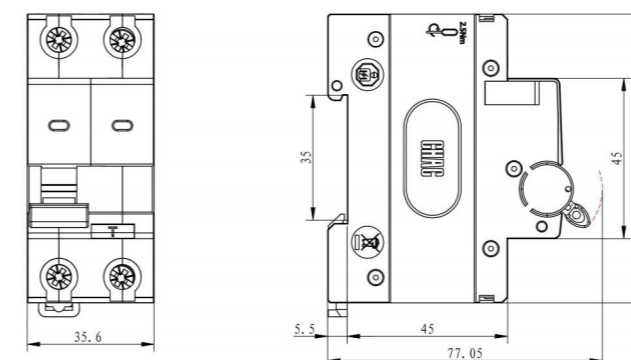

Ordering Specification

- 1.Product Model: PXB2Ln-63
 - 2.Number of Poles: 1P+N,
 - 3.Rated Current & Tripping Curve: [e.g.: C/32A]
 - Tripping Curve: B, C,
 - Rated Current (In): 6A, 10A, 16A, 20A, 25A, 32A, 40A, 50A, 63A
 - 4.Rated Residual Operating Current (IΔn): 30mA,
 - 5.Quantity: [e.g.: 100 pcs]
- Ordering Example:
PXB2Ln-63 1P+N C/32A 30mA 100 pcs

CQB2-40

Miniature Circuit Breaker



Product Features

- Compact structure and robust design
- Low power consumption
- Easy DIN-Rail extraction
- Overload & short circuit protection
- Suitable for industrial, commercial, high-rise and civil residences circuit protection

Type designation

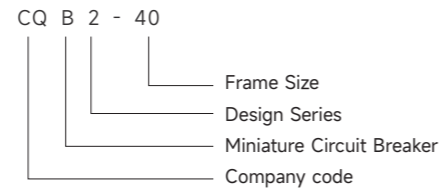

Technical Specifications

Parameter	
Rated voltage	230V~ (1P+N)
Rated current	10A, 16A, 20A, 25A, 32A, 40A
Number of poles	1P+N
Rated short circuit breaking capacity (Icn)	4500 A
Mechanical life	≥ 10,000 operations
Electrical life	≥ 10,000 operations
Tripping curves	B, C, D
Tightening torque	1.5 N·m
Pollution degree	2
Degree of protection	IP20
Overvoltage category	II
Standards	IEC 60898-1, GB/T 10963.1
Certification	CCC

Tripping characteristics (Reference temperature 30°C)

Item	Tripping Curve	Test current I _n (A)	Initial Status	Time limit for tripping or non-tripping	Expected result	Remarks
a	B, C, D	1.13I _n	Cold	t ≤ 1h	Non-tripping	Current smoothly rises to specified value within 5s
b	B, C, D	1.45I _n	Following item a test	t < 1h	Tripping	
c	B, C, D	2.55I _n	Cold	1s < t < 60s (I _n ≤ 32A) 1s < t < 120s (I _n > 32A)	Tripping	
d	B	3I _n	Cold	t ≤ 0.1s	Non-tripping	Switch on the power supply by closing the auxiliary switch
	C	5I _n				
e	D	10I _n	Cold	t < 0.1s	Tripping	Switch on the power supply by closing the auxiliary switch
	B	5I _n				
	C	10I _n				
	D	20I _n				

Note: The term "cold" means that the test is carried out at a reference calibration temperature without load before the test.

Tripping curves

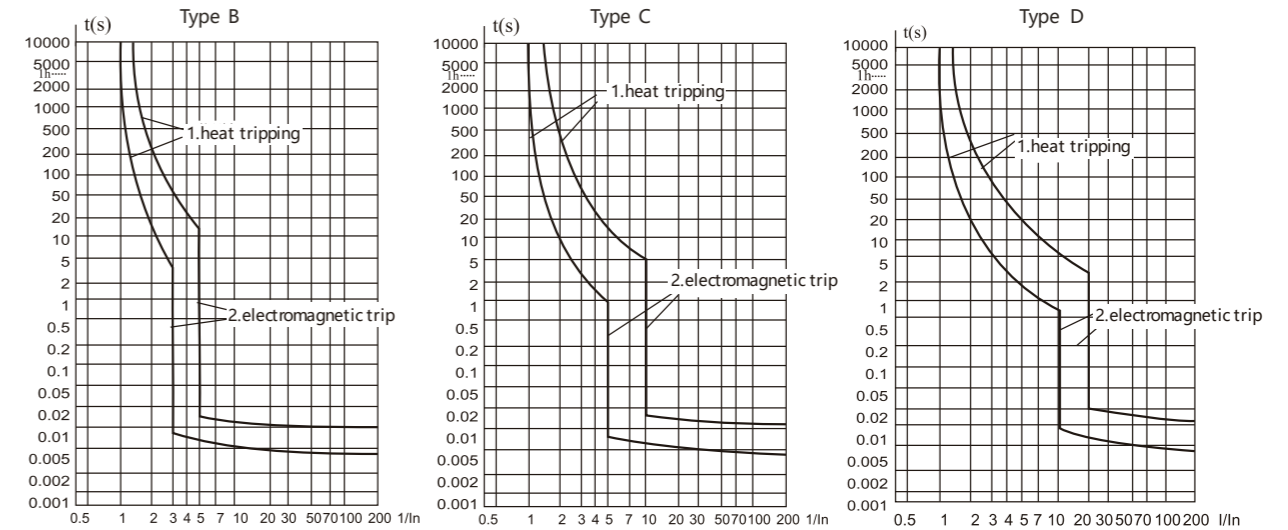

Conductor requirements and cross section

Copper cross-section(mm ²)	Rated current I _n (A)
1	I _n ≤ 6
1.5	6 < I _n ≤ 13
2.5	13 < I _n ≤ 20
4	20 < I _n ≤ 25
6	25 < I _n ≤ 32
10	32 < I _n ≤ 50
16	50 < I _n ≤ 63

Dimensions(mm)

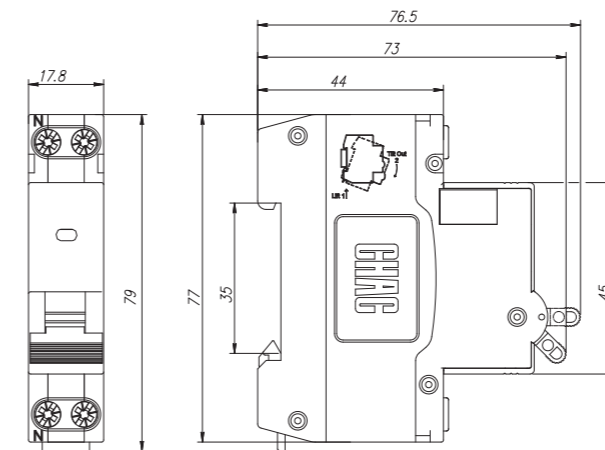

Ordering Specification

Please specify the following when ordering:

- 1.Product Model: CQB2-40
- 2.Number of Poles: 1P+N
- 3.Rated Current & Tripping Curve: [e.g.: C/32A]
 - Tripping Curve (Type): B, C, D
 - Rated Current (I_n): 10A, 16A, 20A, 25A, 32A, 40A

4.Quantity: [e.g.: 200 pcs]

Ordering Example:

CQB2-40 1P+N C/32A 200 pcs

CQB2-63

Miniature Circuit Breaker



Product Features

- High interruption rating capabilities
- Overload & short circuit protection
- Positive isolation
- Suitable for industrial, commercial, high-rise and civil residences circuit protection

Type designation

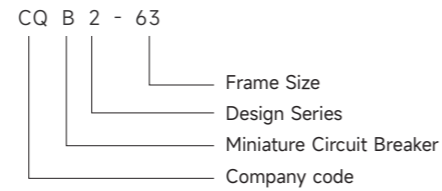

Tripping curves

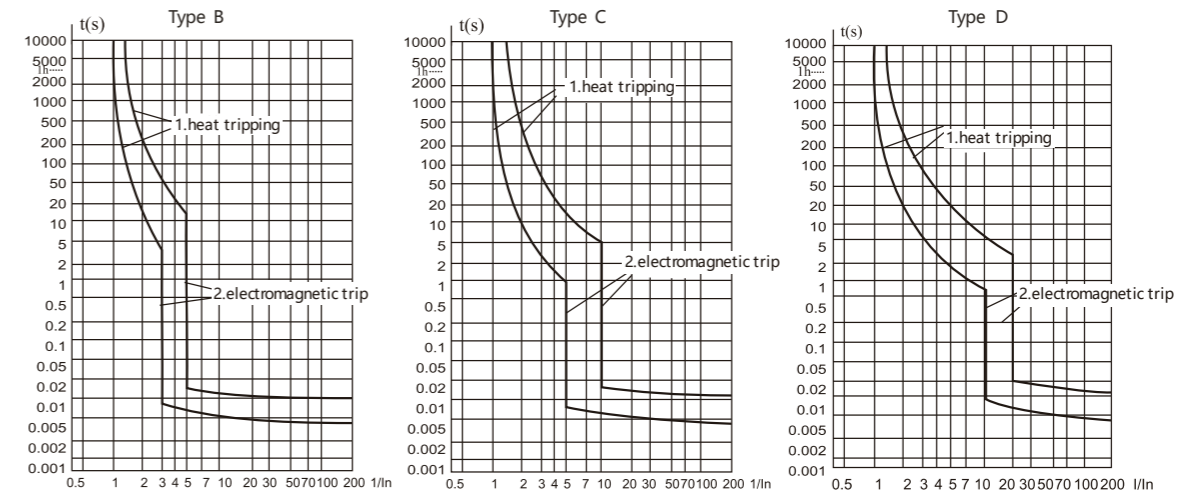

Technical Specifications

Parameter	
Rated insulation voltage	500 V
Rated impulse withstand voltage (Uimp)	4000 V
Rated current	6A, 10A, 16A, 20A, 25A, 32A, 40A, 50A, 63A
Rated frequency	50 Hz / 60 Hz
Number of poles	1P, 1P+N, 2P, 3P, 3P+N, 4P
Rated breaking capacity (Icn = Ics)	6000 A
Mechanical life	≥ 10,000 operations
Electrical life	≥ 6,000 operations
Tripping characteristics	B, C, D
Terminal center distance	45 mm
Degree of protection	IP20
Standards	IEC 60898-1, GB/T 10963.1
Certification	CCC

Tripping characteristics (Reference temperature 30°C)

Item	Tripping Curve	Test current I _n (A)	Initial Status	Time limit for tripping or non-tripping	Expected result	Remarks
a	B, C, D	1.13I _n	Cold	t ≤ 1h	Non-tripping	Current smoothly rises to specified value within 5s
b	B, C, D	1.45I _n	Following item a test	t < 1h	Tripping	
c	B, C, D	2.55I _n	Cold	1s < t < 60s (I _n ≤ 32A) 1s < t < 120s (I _n > 32A)	Tripping	
d	B	3I _n	Cold	t ≤ 0.1s	Non-tripping	Switch on the power supply by closing the auxiliary switch
	C	5I _n				
e	D	10I _n	Cold	t < 0.1s	Tripping	Switch on the power supply by closing the auxiliary switch
	B	5I _n				
	C	10I _n				
	D	20I _n				

Note: The term "cold" means that the test is carried out at a reference calibration temperature without load before the test.

Conductor requirements and cross section

Copper cross-section(mm ²)	Rated current I _n (A)
1	I _n ≤ 6
1.5	6 < I _n ≤ 13
2.5	13 < I _n ≤ 20
4	20 < I _n ≤ 25
6	25 < I _n ≤ 32
10	32 < I _n ≤ 50
16	50 < I _n ≤ 63

Dimensions(mm)

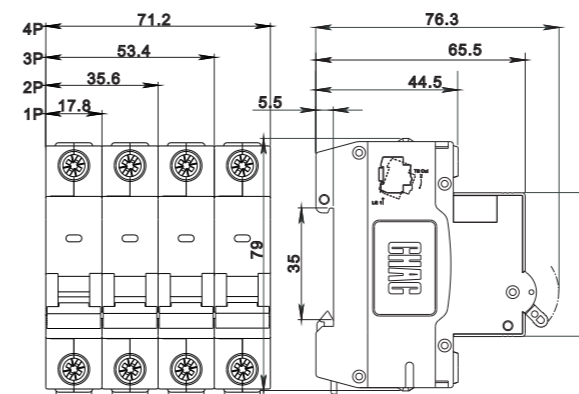

Ordering Specification

Please specify the following when ordering:

- 1.Product Model: CQB2-63
 - 2.Number of Poles: 1P, 1P+N, 2P, 3P, 3P+N, 4P
 - 3.Rated Current & Tripping Curve: [e.g.: C/16A]
 - Tripping Curve (Type): B, C, D
 - Rated Current (I_n): 6A, 10A, 16A, 20A, 25A, 32A, 40A, 50A, 63A
 - 4.Quantity: [e.g.: 100 pcs]
- Ordering Example:
CQB2-63 2P C/16A 100 pcs

CQB2-125

Miniature Circuit Breaker



Product Features

- Overload & short circuit protection
- Positive isolation
- High breaking capacity up to 10KA
- Comprehensive range of accessories suitable for subsequent installation
- Suitable for industrial, commercial, high-rise and civil residences circuit protection

Type designation

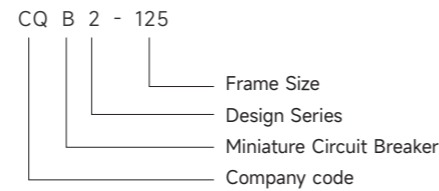

Technical Specifications

Parameter	
Rated voltage (V)	AC230V, AC400V
Rated current (A)	63A, 80A, 100A, 125A
Number of poles	1P, 2P, 3P, 4P
Tripping curves	C, D
Rated short-circuit breaking capacity I _{cu} (A)	10000 A
Rated service short-circuit breaking capacity I _{cs} (A)	7500 A
Rated impulse withstand voltage U _{imp} (V)	4000 V
Mechanical life	≥ 8500 operations
Electrical life	≥ 1500 operations
Degree of protection	IP20
Standards	IEC 60947-2, GB/T 14048.2
Certification	CCC

Tripping characteristics (Reference temperature 30°C)

Item	Tripping Curve	Test current I _n (A)	Initial Status	Time limit for tripping or non-tripping	Expected result	Remarks
a	C, D	1.05I _n	Cold	1h(I _n ≤63A) 2h(I _n >63A)	Non-tripping	Current smoothly rises to specified value within 5s
b	C, D	1.3I _n	Following item a test	1h(I _n ≤63A) 2h(I _n >63A)	Tripping	
c	C, D	2I _n	Cold	1s<t<300s	Tripping	
d	C	8I _n ×80%	Cold	t ≤ 0.2s	Non-tripping	Switch on the power supply by closing the auxiliary switch
	D	12I _n ×80%				
e	C	8I _n ×80%	Cold	t < 0.2s	Tripping	Switch on the power supply by closing the auxiliary switch
	D	12I _n ×80%				

Note: The term "cold" means that the test is carried out at a reference calibration temperature without load before the test.

Tripping curves

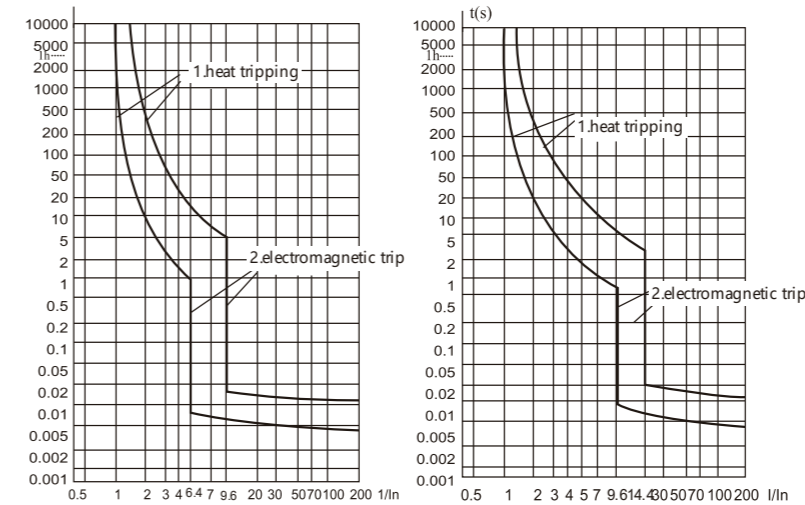

Conductor requirements and cross section

Copper cross-section(mm ²)	Rated current I _n (A)
16	63A
25	80A
35	100A
50	125A

Dimensions(mm)

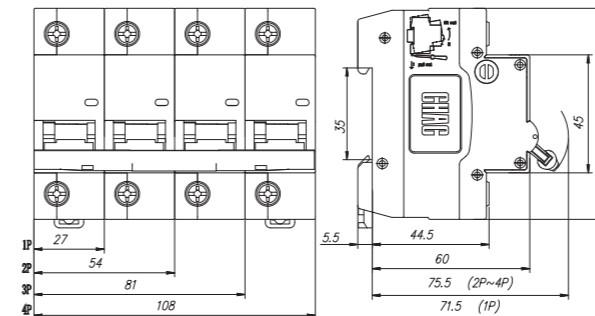

Ordering Specification

Please specify the following when ordering:

- 1.Product Model: CQB2-125
- 2.Number of Poles: 1P, 2P, 3P, 4P
- 3.Tripping Curve Type: C or D
- 4.Rated Current (I_n): 63A, 80A, 100A, 125A
- 5.Quantity: [e.g.: 100 pcs]

Ordering Example:

CQB2-125 2P C/100A 100 pcs

CQB2LE-40

Residual Current Circuit Breaker with Overcurrent Protection - Electronic Type



Product Features

- Sensitive protection: 30mA earth leakage protection with 0.1s fast response
- Dual safety: Overload and short-circuit protection in one device
- Wide applicability: 6-40A multi-current options for various loads
- Compact design: 1P+N configuration saves space

Type designation

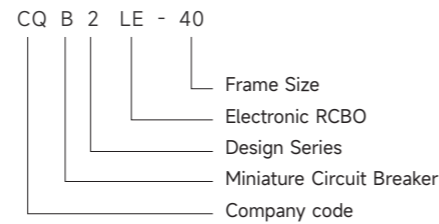

Tripping curves

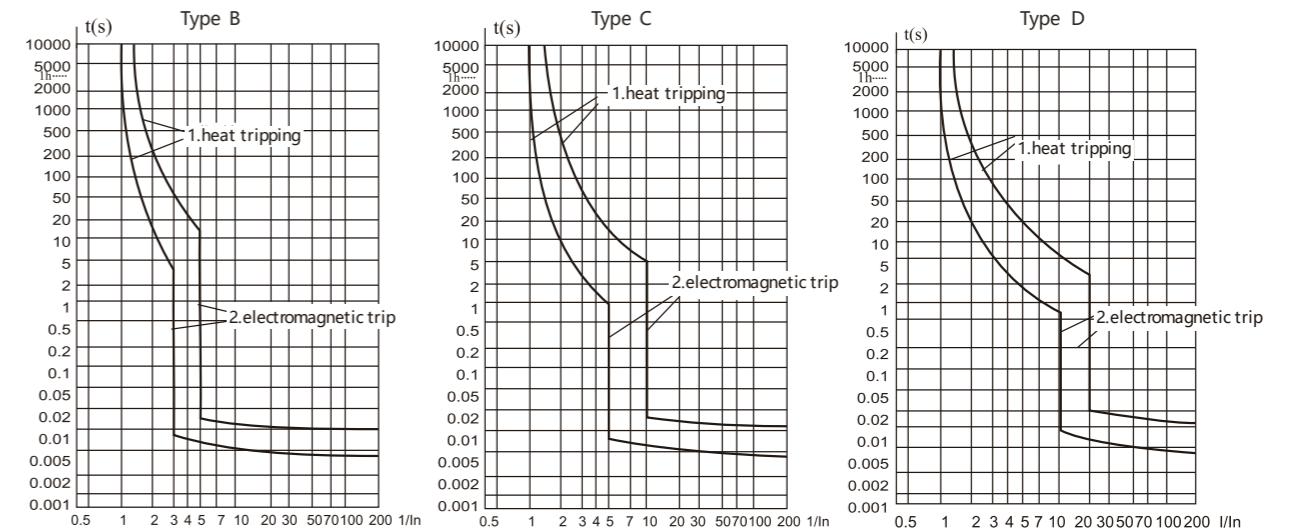

Technical Specifications

Parameter	
Rated voltage	230V~
Rated current	6A, 10A, 16A, 20A, 25A, 32A, 40A
Frequency	50Hz/60Hz
Number of poles	1P+N
Rated residual operating current (IΔn)	30 mA
Rated residual non-operating current	15 mA
Rated short-circuit breaking capacity (Icu)	4500 A
Rated residual making and breaking capacity	500 A
Tripping time	≤ 0.1 s
Mechanical life	10,000 operations
Electrical life	10,000 operations
Tripping characteristics	B, C, D
Pollution degree	2
Degree of protection	IP20
Standards	IEC 61009-1, GB/T 16917.1
Certification	CCC

Conductor requirements and cross section

Copper cross-section(mm ²)	Rated current In(A)
1	In≤6
1.5	6 < In≤13
2.5	13 < In≤20
4	20 < In≤25
6	25 < In≤32
10	32 < In≤40

Dimensions(mm)

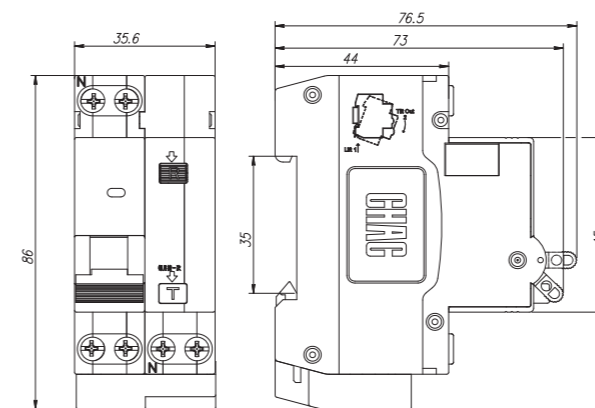

Ordering Specification

Please specify the following when ordering:

- 1.Product Model: CQB2LE-40
- 2.Number of Poles: 1P+N
- 3.Rated Current & Tripping Curve: [e.g.: C/16A]
 - Tripping Curve: B, C, D
 - Rated Current (In): 6A, 10A, 16A, 20A, 25A, 32A, 40A
- 4.Rated Residual Operating Current (IΔn): 30mA
- 5.Quantity: [e.g.: 100 pcs]

Ordering Example:

CQB2LE-40 1P+N C/16A 30mA 100 pcs

Tripping characteristics (Reference temperature 30°C)

Item	Tripping Curve	Test current In(A)	Initial Status	Time limit for tripping or non-tripping	Expected result	Remarks
Delay	≤40	Cold	1.13In	≤1h	Non-tripping	
Delay	≤40	Following previous test	1.45In	<1h	Tripping	Current smoothly rises to specified value in 5s
Delay	≤32	Cold	2.55In	1<t<60s	Tripping	
Delay	40	Cold	2.55In	1<t<120s	Tripping	
Instantaneous	Any value	Cold	3、5、10In	≤0.1s	Non-tripping	B、C、D
Instantaneous	Any value	Cold	5、10、20In	<0.1s	Tripping	B、C、D

Note: The term "cold" means that the test is carried out at a reference calibration temperature without load before the test.

CQB2LE-63

Residual Current Circuit Breaker with
Overcurrent Protection - Electronic Type



Product Features

- Balanced performance: 63A rating with 6000A breaking capacity
- Fast protection: $\leq 0.1s$ tripping time for quick fault isolation
- Flexible application: 2P to 4P options for single/three-phase systems
- Easy installation: Standard size for simple integration

Type designation

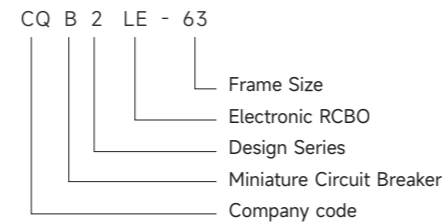

Tripping curves

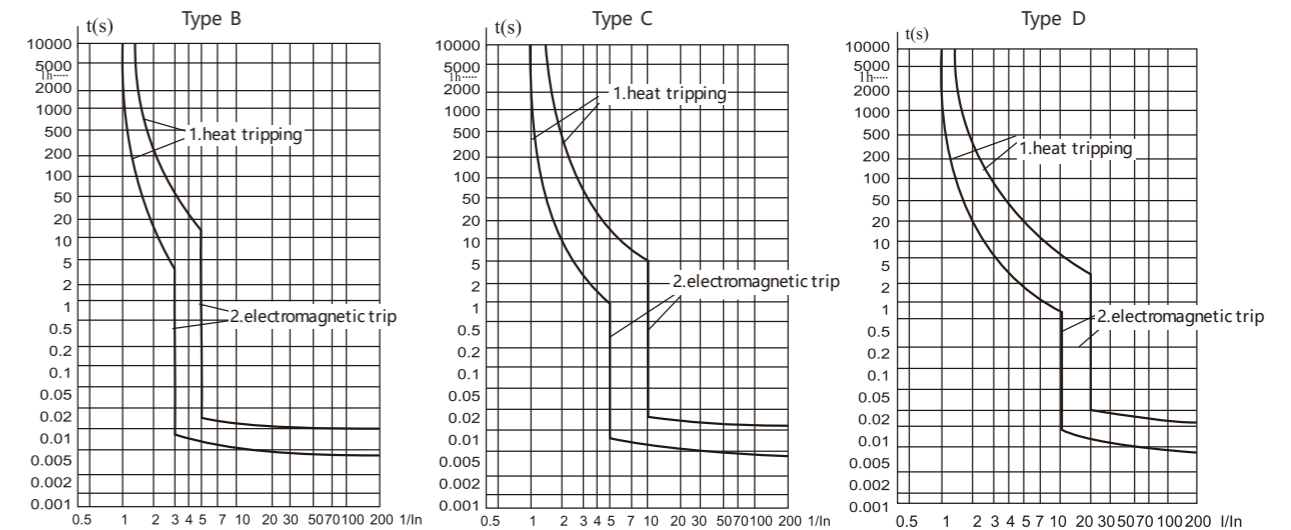

Technical Specifications

Parameter	
Rated voltage	230V~ (2P, 1P+N) / 400V~ (3P, 4P, 3P+N)
Rated current	6A, 10A, 16A, 20A, 25A, 32A, 40A, 50A, 63A
Number of poles	2P, 3P, 4P, 1P+N, 3P+N
Rated breaking capacity (Icn = Ics)	6000 A
Rated residual operating current (IΔn)	30, 50, 100, 300 mA
Rated residual non-operating current	0.5 IΔn
Rated residual making and breaking capacity	2000 A
Tripping time	≤ 0.1 s
Mechanical life	4000 operations
Electrical life	4000 operations
Tripping curves	B, C, D
Degree of protection	IP20
Oversoltage category	III
Standards	IEC 61009-1, GB/T 16917.1
Certification	CCC

Tripping characteristics (Reference temperature 30°C)

Item	Tripping Curve	Test current I _n (A)	Initial Status	Time limit for tripping or non-tripping	Expected result	Remarks
Delay	≤ 63	Cold	1.13I _n	$\leq 1h$	Non-tripping	
Delay	≤ 63	Following previous test	1.45I _n	$< 1h$	Tripping	Current smoothly rises to specified value in 5s
Delay	≤ 32	Cold	2.55I _n	1<t<60s	Tripping	
Delay	>32	Cold	2.55I _n	1<t<120s	Tripping	
Instantaneous	Any value	Cold	3, 5, 10I _n	$\leq 0.1s$	Non-tripping	B, C, D
Instantaneous	Any value	Cold	5, 10, 20I _n	$< 0.1s$	Tripping	B, C, D

Note: The term "cold" means that the test is carried out at a reference calibration temperature without load before the test.

Conductor requirements and cross section

Copper cross-section(mm ²)	Rated current I _n (A)
1	I _n ≤6
1.5	6 < I _n ≤13
2.5	13 < I _n ≤20
4	20 < I _n ≤25
6	25 < I _n ≤32
10	32 < I _n ≤50
16	50 < I _n ≤63

Dimensions(mm)

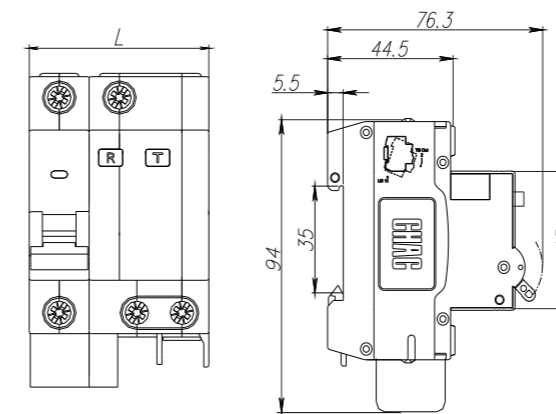

Poles	L
1P+N	53.4
2P	71.2
3P	102.4
3P+N	115.8
4P	133.6

Ordering Specification

Please specify the following when ordering:

- 1.Product Model: CQB2LE-63
 - 2.Number of Poles: 1P+N, 2P, 3P, 3P+N, 4P
 - 3.Rated Current & Tripping Curve: [e.g.: C/32A]
 - Tripping Curve: B, C, D
 - Rated Current (I_n): 6A, 10A, 16A, 20A, 25A, 32A, 40A, 50A, 63A
 - 4.Rated Residual Operating Current (IΔn): 30mA, 50mA, 100mA, 300mA
 - 5.Quantity: [e.g.: 100 pcs]
- Ordering Example:
CQB2LE-63 2P C/32A 30mA 100 pcs

CQB2LE-125

Residual Current Circuit Breaker with Overcurrent Protection - Electronic Type



Product Features

- Industrial grade: 125A high rated current for main distribution
- Strong breaking: 10kA breaking capacity handles severe faults
- Flexible settings: 30-300mA adjustable sensitivity
- Multiple poles: 1P+N to 4P options for three-phase systems
- High reliability: Long mechanical life for frequent operation

Type designation

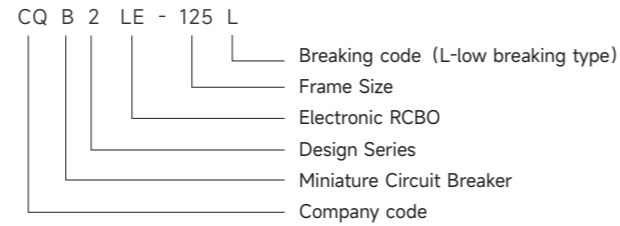

Technical Specifications

Parameter	
Rated voltage	230V~ (1P+N/2P), 400V~ (3P/3P+N/4P)
Rated current	63A, 80A, 100A, 125A
Number of poles	1P+N, 2P, 3P, 3P+N, 4P
Rated breaking capacity Icu (A)	10000 A, 6000 A (Lower type)
Rated sensitivity IΔn	30 mA, 50 mA, 75 mA, 100 mA, 300 mA
Mechanical & Electrical life	Mechanical ≥ 8500, Electrical ≥ 1500
Tripping curves	C, D
Tightening torque (N·m)	3.5
Pollution degree	2
Degree of protection	IP20
Overvoltage category	III
Standards	IEC 60947-2, GB/T 14048.2
Certification	CCC

Tripping characteristics (Reference temperature 30°C)

Item	Tripping Curve	Test current I _n (A)	Initial Status	Time limit for tripping or non-tripping	Expected result	Remarks
a	C, D	1.05I _n	Cold	1h(I _n ≤63A) 2h(I _n >63A)	Non-tripping	Current smoothly rises to specified value within 5s
b	C, D	1.3I _n	Following item a test	1h(I _n ≤63A) 2h(I _n >63A)	Tripping	
c	C, D	2I _n	Cold	1s<t<300s	Tripping	
d	C	8I _n ×80%	Cold	t ≤ 0.2s	Non-tripping	Switch on the power supply by closing the auxiliary switch
	D	12I _n ×80%				
e	C	8I _n ×80%	Cold	t < 0.2s	Tripping	Switch on the power supply by closing the auxiliary switch
	D	12I _n ×80%				

Note: The term "cold" means that the test is carried out at a reference calibration temperature without load before the test.

Tripping curves

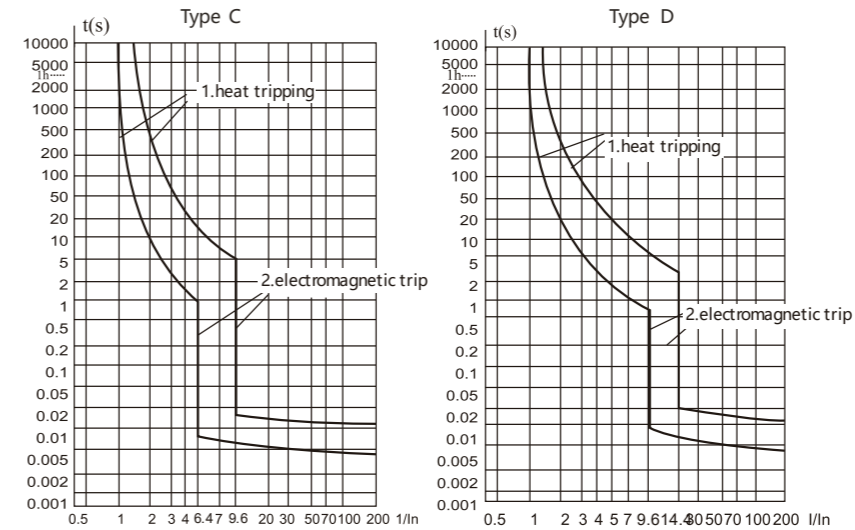

Conductor requirements and cross section

Copper cross-section(mm ²)	Rated current I _n (A)
16	63A
25	80A
35	100A
50	125A

Dimensions(mm)

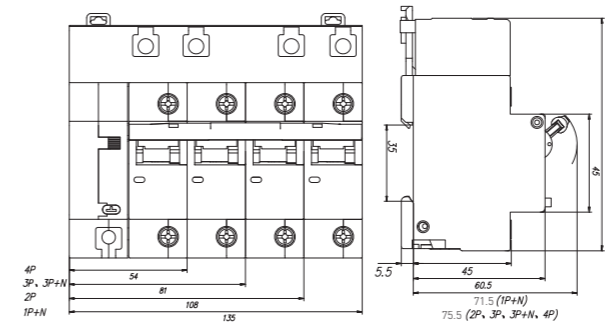

Ordering Specification

Please specify the following when ordering:

- 1.Product Model: CQB2LE-125
- 2.Number of Poles: 1P+N, 2P, 3P, 3P+N, 4P
- 3.Rated Current & Tripping Curve: [e.g.: C/100A]
 - Tripping Curve: C, D
 - Rated Current (I_n): 63A, 80A, 100A, 125A
- 4.Rated Residual Operating Current (IΔn): 30mA, 50mA, 75mA, 100mA, 300mA
- 5.Quantity: [e.g.: 100 pcs]

Ordering Example:

CQB2LE-125 3P C/100A 100mA 100 pcs

CQD2-125

Switch Disconnecter



Product Features

- Rated insulation voltage of 500V, High rated current (up to 125A) and strong short-time withstand current.
- Complies with the requirements for isolation function. It features safe isolation distance and a clear "OFF" position indication, ensuring the circuit is completely isolated from the power source when switched off, thereby safeguarding equipment and personnel.
- Available in 1P to 4P and multiple current ratings.

Type designation

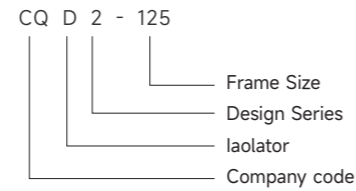

Technical Specifications

Parameter	
Rated voltage (Ue)	AC 230 V, AC 400 V
Rated current (Ie)	32A, 40A, 50A, 63A, 80A, 100A, 125A
Number of poles	1P, 2P, 3P, 4P
Rated short-time withstand current (Icw)	12 Ie (t = 1 s)
Rated short-circuit making capacity (Icm)	20 Ie (t = 0.05 s)
Rated impulse withstand voltage (Uimp)	6 kV (1.2/50 μs, 2000 m)
Mechanical & Electrical life	Mechanical ≥ 8500, Electrical ≥ 1500
Standards	IEC 60947-3, GB/T 14048.3
Certification	CCC

Conductor requirements and cross section

Copper cross-section(mm ²)	Rated current In(A)
6	32A
10	40A
10	50A
16	63A
25	80A
35	100A
50	125A

Dimensions(mm)

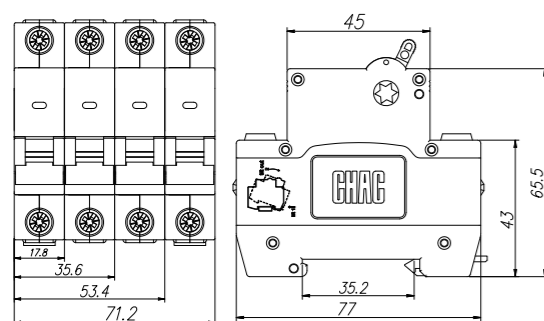

Ordering Specification

Please specify the following when ordering:

- 1.Product Model: CQD2-125
- 2.Number of Poles: 1P, 2P, 3P, 4P
- 3.Rated Current: 32A, 63A, 100A
- 4.Quantity: [e.g.: 100 pcs]

Ordering Example:
CQD2-125 2P 32A 100 pcs

CQAF2

Auxiliary Switch



Product Features

- Designed to be assembled with CQB2 circuit breakers to provide remote signal indication for the breaker's ON/OFF status.
- Suitable for both AC 230V and DC 110V control circuits.
- Complies with GB/T 14048.5 and IEC 60947-5-1 standards, with a mechanical life of no less than 10,000 operations.

Type designation

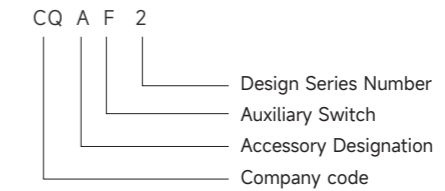

Technical Specifications

Parameter		
AC-15	Rated Operational Voltage	AC 230V 50Hz
	Rated operating current	6A
DC-13	Rated Operational Voltage	DC110V
	Rated operating current	1A
Mechanical Life	10000	
Standards	GB/T 14048.5, IEC 60947-5-1	

Dimensions(mm)

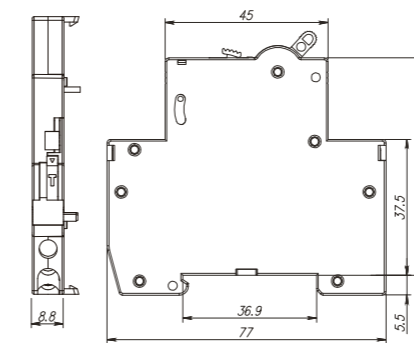

Ordering Specification

Please specify the following when ordering:

- Product Model: CQAF2
- Quantity: [e.g.: 100 pcs]

Ordering Example:
CQAF2 100 pcs

CQAS2 Alarm Switch



Product Features

- Designed to be assembled with CQB2 circuit breakers to provide a remote alarm signal upon fault tripping (e.g., due to overload or short circuit).
- Suitable for both AC 230V and DC 110V control circuits.
- Complies with GB/T 14048.5 and IEC 60947-5-1 standards, with a mechanical life of no less than 10,000 operations.
- Rated operational current: 6A under utilization category AC-15; 1A under utilization category DC-13.

Type designation

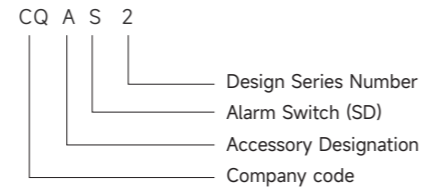

Technical Specifications

Parameter		
AC-15	Rated Operational Voltage	AC 230V 50Hz
	Rated operating current	6A
DC-13	Rated Operational Voltage	DC110V
	Rated operating current	1A
Mechanical Life	10000	
Standards	GB/T 14048.5, IEC 60947-5-1	

Dimensions(mm)

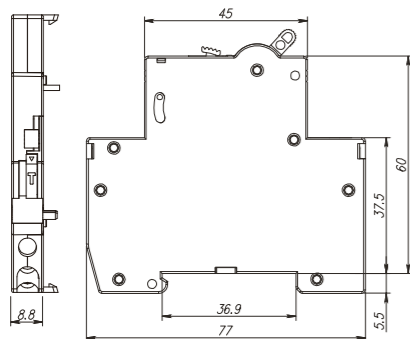

Ordering Specification

Please specify the following when ordering:

- Product Model: CQAS2
- Quantity: [e.g.: 100 pcs]

Ordering Example:

CQAS2 100 pcs

CQAM2 Shunt Release



Product Features

- Designed to be assembled with CQB2 circuit breakers to achieve remote tripping and opening of the breaker by applying the rated voltage.
- Features a broad operating voltage range (160V - 260V), ensuring reliable operation and stability of remote control within this range.
- Complies with GB/T 14048.5 and IEC 60947-5-1 standards, with a rated insulation voltage of 415V.

Type designation

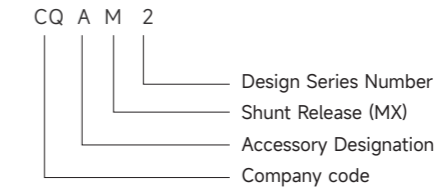

Technical Specifications

Parameter		
AC-15	Rated Operational Voltage (V)	AC 230V 50Hz
	Rated Insulation Voltage (V)	415V
Operating Characteristics	When the voltage is between 160-260V, the trip unit can reliably operate.	
Mechanical Life	4000	
Standards	GB/T 14048.5, IEC 60947-5-1	

Conductor requirements and cross section

Copper cross-section(mm ²)
1 X 2.5

Dimensions(mm)

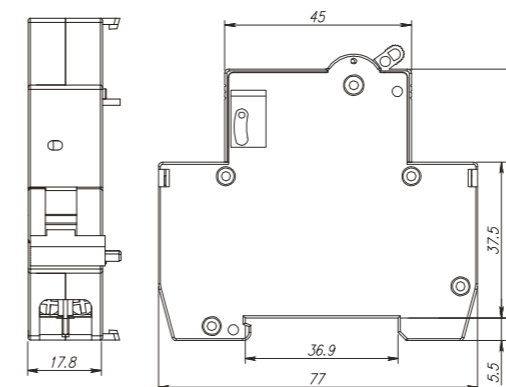

Ordering Specification

Please specify the following when ordering:

- Product Model: CQAM2
- Quantity: [e.g.: 100 pcs]

Ordering Example:

CQAM2 100 pcs

CQAU2

Over-Voltage & Under-Voltage Protector



Product Features

- Designed to be assembled with CQB2 circuit breakers to monitor line voltage and automatically trip to protect downstream equipment in the event of over-voltage or under-voltage conditions.
- Over-voltage tripping: $\geq (265\pm 10)V$; Under-voltage tripping: $\leq (165\pm 10)V$. Normal operating voltage range: 175V - 255V.
- Complies with GB/T 14048.5 and IEC 60947-5-1 standards, with a rated insulation voltage of 415V.

Type designation

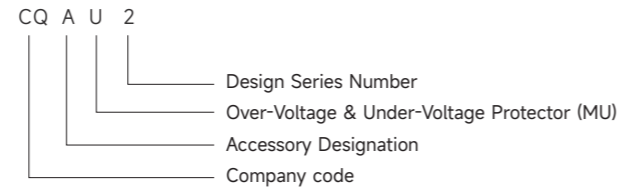

Technical Specifications

Parameter		
AC-15	Rated Operational Voltage (V)	AC 230V 50Hz
	Rated Insulation Voltage (V)	415V
Operating Characteristics	Maintains long-term circuit breaker operation at voltages between 175V - 255V.	
	Trips at voltages $\geq 265\pm 10V$ (Over-Voltage) Trips at voltages $\leq 165\pm 10V$ (Under-Voltage)	
Mechanical Life	Not less than 4,000 operations.	
Standards	GB/T 14048.5, IEC 60947-5-1	

Conductor requirements and cross section

Copper cross-section(mm ²)
1 X 2.5

Dimensions(mm)

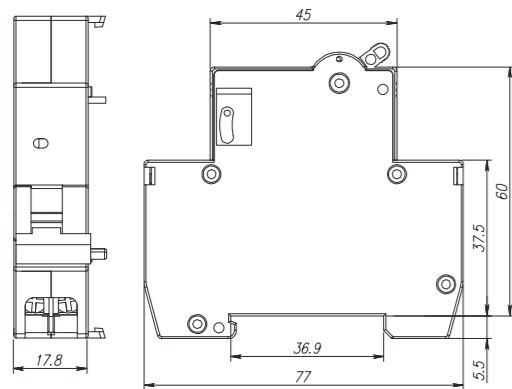

Ordering Specification

Please specify the following when ordering:

- Product Model: CQAU2
- Quantity: [e.g.: 100 pcs]

Ordering Example:

CQAU2 100 pcs

CQAX2

Shunt Release + Auxiliary Switch Combination Unit



Product Features

- Combines the functions of a Shunt Release and an Auxiliary Switch into a single module, saving installation space.
- Capable of both remote tripping operation (Shunt Release function) and providing breaker status signals (Auxiliary Switch function).
- The shunt release unit operates reliably within a wide voltage range of 160V - 260V.
- Dual Supply Signal Compatibility: The auxiliary switch part is suitable for both AC 230V and DC 110V control circuits.

Type designation

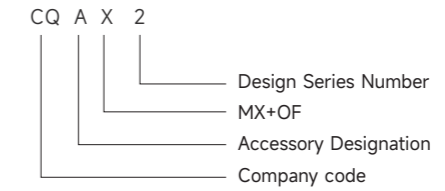

Technical Specifications

Parameter		
AC-15	Rated Operational Voltage	AC 230V 50Hz
	Rated Insulation Voltage	415V
DC-13	Rated Operational Voltage	DC110V
	Rated operating current	1A
Operating Characteristics	When the voltage is between 160-260V, the trip unit can reliably operate.	
Mechanical Life	Not less than 4,000 operations.	
Standards	GB/T 14048.5, IEC 60947-5-1	

Conductor requirements and cross section

Copper cross-section(mm ²)
1 X 2.5

Dimensions(mm)

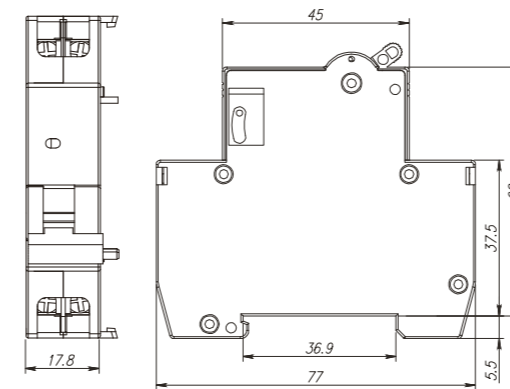

Ordering Specification

Please specify the following when ordering:

- Product Model: CQAX2
- Quantity: [e.g.: 100 pcs]

Ordering Example:

CQAX2 100 pcs

CQB2H-63

Miniature Circuit Breaker



Product Features

- Overload & short circuit protection
- Positive isolation
- High breaking capacity up to 10KA
- Comprehensive range of accessories suitable for subsequent installation
- Suitable for industrial, commercial, high-rise and civil residences circuit protection

Type designation

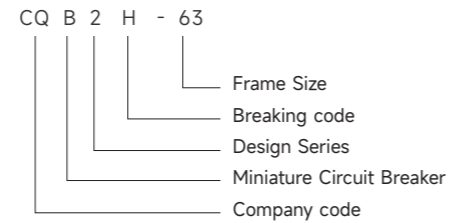

Technical Specifications

Parameter	
Rated voltage	230V/400V (1P), 400V~ (2P/3P/4P)
Rated current	6A, 10A, 16A, 20A, 25A, 32A, 40A, 50A, 63A
Number of poles	1P, 2P, 3P, 4P
Rated short circuit breaking capacity Icn	10000 A
Mechanical & Electrical life	Mechanical ≥ 20000, Electrical ≥ 6000
Tripping characteristics	B, C, D
Tightening torque (N·m)	3.5
Pollution degree	2
Degree of protection	IP20
Overvoltage category	II, III
Standards	IEC 60898-1, GB/T 10963.1

Tripping characteristics (Reference temperature 30°C)

Item	Tripping Curve	Test current I _n (A)	Initial Status	Time limit for tripping or non-tripping	Expected result	Remarks
a	B, C, D	1.13I _n	Cold	t ≤ 1h	Non-tripping	Current smoothly rises to specified value within 5s
b	B, C, D	1.45I _n	Following item a test	t < 1h	Tripping	
c	B, C, D	2.55I _n	Cold	1s < t < 60s (I _n ≤ 32A) 1s < t < 120s (I _n > 32A)	Tripping	
d	B	3I _n	Cold	t ≤ 0.1s	Non-tripping	Switch on the power supply by closing the auxiliary switch
	C	5I _n				
	D	10I _n				
e	B	5I _n	Cold	t < 0.1s	Tripping	Switch on the power supply by closing the auxiliary switch
	C	10I _n				
	D	20I _n				

Note: The term "cold" means that the test is carried out at a reference calibration temperature without load before the test.

Tripping curves

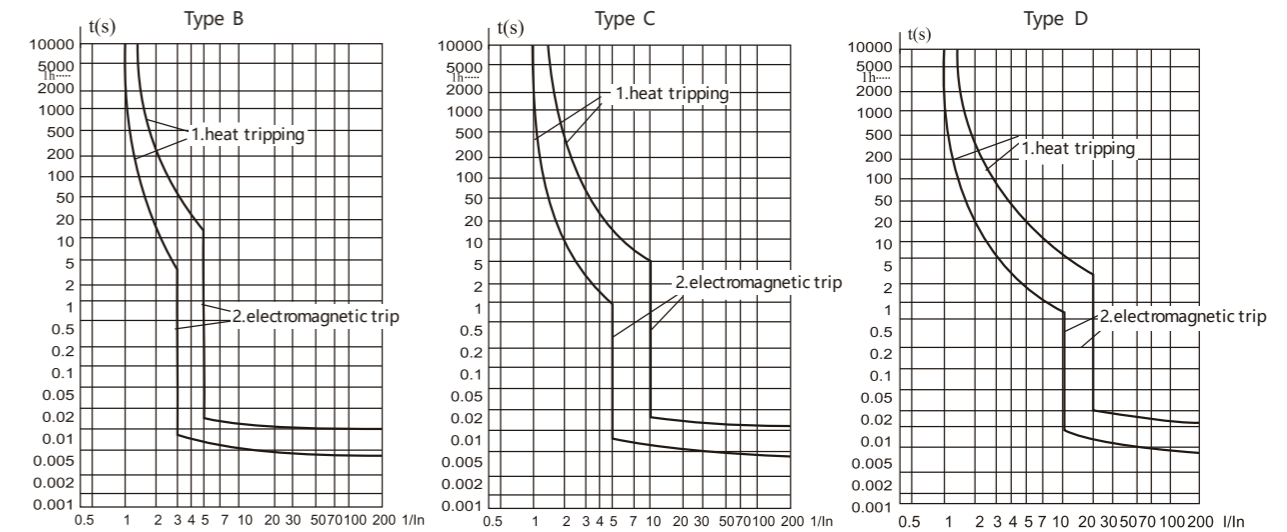

Conductor requirements and cross section

Copper cross-section(mm ²)	Rated current I _n (A)
1.5	6 < I _n ≤ 13
2.5	13 < I _n ≤ 20
4	20 < I _n ≤ 25
6	25 < I _n ≤ 32
10	32 < I _n ≤ 50
16	50 < I _n ≤ 63

Dimensions(mm)

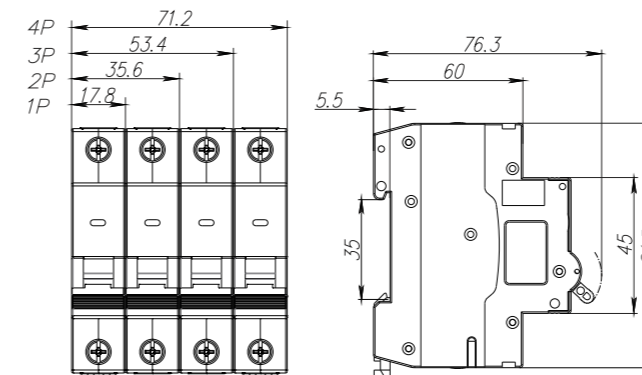

Ordering Specification

Please specify the following when ordering:

- Product Model: CQB2H-63
 - Number of Poles: 1P, 2P, 3P, 4P
 - Tripping Curve & Rated Current: [e.g.: C/32A]
 - Tripping Curve: B, C, D
 - Rated Current (I_n): 6A, 10A, 16A, 20A, 25A, 32A, 40A, 50A, 63A
 - Quantity: [e.g.: 100 pcs]
- Ordering Example:
CQB2H-63 2P C/32A 100 pcs

CQB2HL-63

Residual Current Circuit Breaker with Overcurrent Protection - Electronic Type



Product Features

- High performance: 10kA breaking capacity for reliable protection
- Precise matching: B/C/D tripping curves for different loads
- Multiple options: 30-300mA five-level sensitivity selection
- Long lifespan: 20,000 mechanical operations ensure durability
- Full protection: IP20 rating for various environments

Type designation

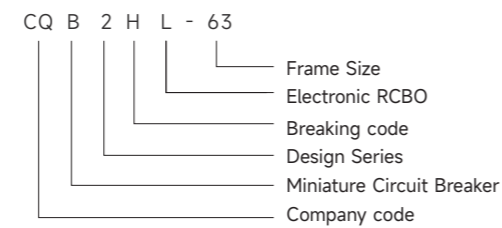

Technical Specifications

Parameter	
Rated voltage	230V~ (1P+N, 2P), 400V~ (3P, 3P+N, 4P)
Rated current	6A, 10A, 16A, 20A, 25A, 32A, 40A, 50A, 63A
Rated tripping current I Δ n	30mA, 50mA, 75mA, 100mA, 300mA
Number of poles	1P+N, 2P, 3P, 3P+N, 4P
Rated breaking capacity I c n	10000 A
Mechanical & Electrical life	Mechanical \geq 20000, Electrical \geq 6000
Tightening torque (N·m)	3.5
Pollution degree	2
Degree of protection	IP20
Oversvoltage category	II, III
Tripping characteristics	2
Standards	IEC 61009-1, GB/T 16917.1
Certification	CCC

Tripping characteristics (Reference temperature 30°C)

Item	Tripping Curve	Test current I Δ n(A)	Initial Status	Time limit for tripping or non-tripping	Expected result	Remarks
a	B, C, D	1.13I n	Cold	t \leq 1h	Non-tripping	Current smoothly rises to specified value within 5s
b	B, C, D	1.45I n	Following item a test	t < 1h	Tripping	
c	B, C, D	2.55I n	Cold	1s < t < 60s (I n \leq 32A) 1s < t < 120s (I n > 32A)	Tripping	
d	B	3I n	Cold	t \leq 0.1s	Non-tripping	Switch on the power supply by closing the auxiliary switch
	C	5I n				
e	D	10I n	Cold	t < 0.1s	Tripping	Switch on the power supply by closing the auxiliary switch
	B	5I n				
	C	10I n				

Note: The term "cold" means that the test is carried out at a reference calibration temperature without load before the test.

Tripping curves

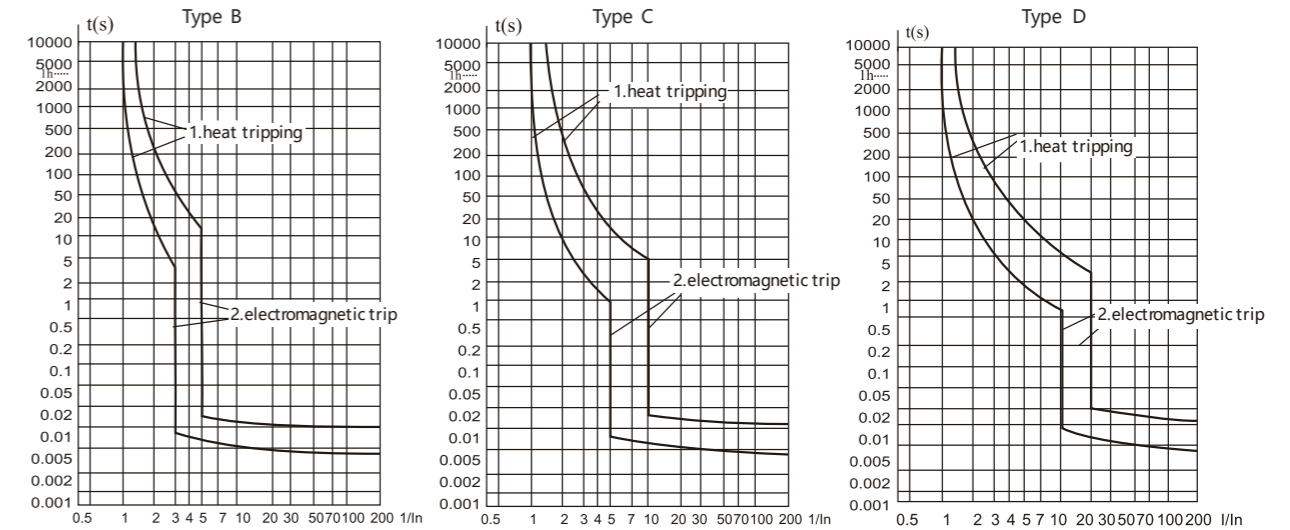

Conductor requirements and cross section

Copper cross-section(mm ²)	Rated current I n (A)
1	I n \leq 6
1.5	6 < I n \leq 13
2.5	13 < I n \leq 20
4	20 < I n \leq 25
6	25 < I n \leq 32
10	32 < I n \leq 50
16	50 < I n \leq 63

Dimensions(mm)

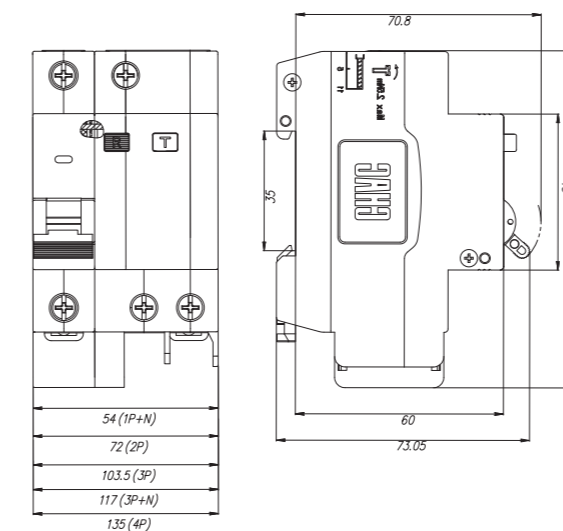

Ordering Specification

Please specify the following when ordering:

- Product Model: CQB2HL-63
- Poles & Residual Operating Current: [e.g.: 2P / 30mA]
 - Number of Poles: 1P+N, 2P, 3P, 3P+N, 4P
 - Rated Residual Operating Current (I Δ n): 30mA, 50mA, 100mA, 300mA
- Tripping Curve & Rated Current: [e.g.: C/32A]
 - Tripping Curve: B, C, D
 - Rated Current (I n): 6A, 10A, 16A, 20A, 25A, 32A, 40A, 50A, 63A
- Quantity: [e.g.: 100 pcs]

Ordering Example:

CQB2HL-63 2P C/32A 30mA 100 pcs

CQB3-63

Miniature Circuit Breaker



Product Features

- High Breaking Capacity
6kA short-circuit protection rating ensures reliable circuit interruption under fault conditions
- Wide Current Range
6-63A ratings with B/C/D tripping characteristics for residential and commercial applications
- Long Service Life
≥10,000 mechanical operations and ≥6,000 electrical operations

Type designation

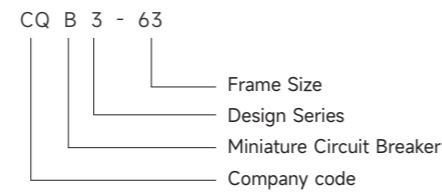

Technical Specifications

Parameter	
Rated Insulation Voltage (Ui)	500V
Rated Impulse Withstand Voltage (Uimp)	4000V
Rated Current (In)	6, 10, 16, 20, 25, 32, 40, 50, 63
Rated Frequency	50Hz / 60Hz
Number of Poles	1P, 1P+N, 2P, 3P, 3P+N, 4P
Rated Breaking Capacity (Icn)	6000A
Mechanical Life & Electrical Life	Mechanical≥10000, Electrical≥6000
Tripping Curves	B, C, D
Mounting Rail	45mm
Degree of Protection (IP Code)	IP20
Applicable Standards	IEC60898-1, GB/ T10963.1
Certification	CCC

Tripping characteristics (Reference temperature 30°C)

Item	Tripping Curve	Test current In(A)	Initial Status	Time limit for tripping or non-tripping	Expected result	Remarks
a	B, C, D	1.13In	Cold	$t \leq 1h$	Non-tripping	Current smoothly rises to specified value within 5s
b	B, C, D	1.45In	Following item a test	$t < 1h$	Tripping	
c	B, C, D	2.55In	Cold	$1s < t < 60s$ ($I_n \leq 32A$) $1s < t < 120s$ ($I_n > 32A$)	Tripping	
d	B	3In	Cold	$t \leq 0.1s$	Non-tripping	Switch on the power supply by closing the auxiliary switch
	C	5In				
e	D	10In	Cold	$t < 0.1s$	Tripping	Switch on the power supply by closing the auxiliary switch
	B	5In				
	C	10In				
	D	20In				

Note: The term "cold" means that the test is carried out at a reference calibration temperature without load before the test.

Tripping curves

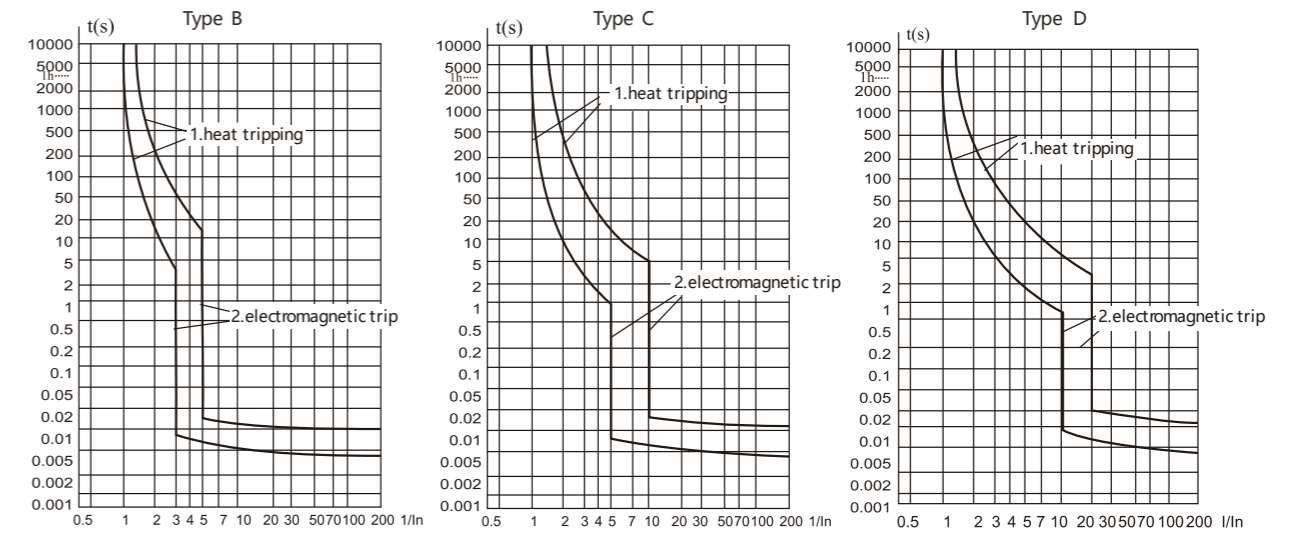

Conductor requirements and cross section

Copper cross-section(mm ²)	Rated current In(A)
1	In≤6
1.5	6 < In≤13
2.5	13 < In≤20
4	20 < In≤25
6	25 < In≤32
10	32 < In≤50
16	50 < In≤63

Dimensions(mm)

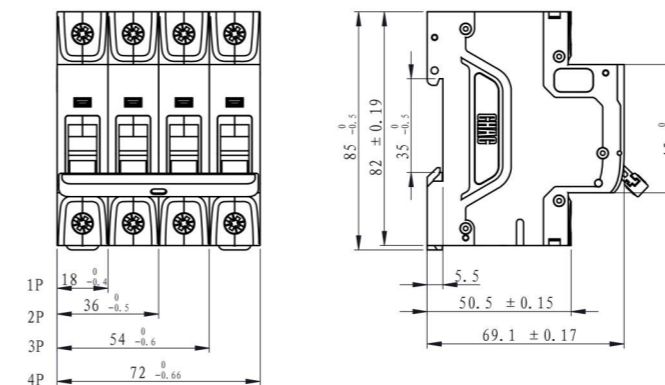

Ordering Specification

- Product Model: CQB3-63
 - Number of Poles: 1P, 1P+N, 2P, 3P, 3P+N, 4P
 - Rated Current & Tripping Curve: [e.g.: C/32A]
 - Tripping Curve: B, C, D
 - Rated Current (In): 6A, 10A, 16A, 20A, 25A, 32A, 40A, 50A, 63A
 - Quantity: [e.g.: 100 pcs]
- Ordering Example:
CQB3-63 2P C/32A 100 pcs

CQB3LE-63

Residual Current Circuit Breaker with Overcurrent Protection - Electronic Type



Product Features

- Earth Leakage Protection
30/50/100/300mA sensitivity options provide personal protection against electric shock
- Dual Protection Function
Combines overload/short-circuit protection with earth leakage protection
- Fast Response
≤0.1s tripping time for quick fault circuit interruption
- Flexible Configurations
1P+N, 2P, 3P, 3P+N and 4P versions available

Type designation

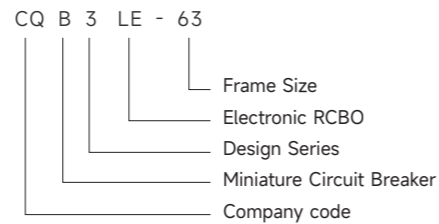

Technical Specifications

Parameter	
Rated voltage	230V~ (2P, 1P+N) / 400V~ (3P, 4P, 3P+N)
Rated current	6, 10, 16, 20, 25, 32, 40, 50, 63 A
Number of Poles	2P, 3P, 4P, 1P+N, 3P+N
Rated breaking capacity (I _{cn} = I _{cs})	6000 A
Rated residual operating current (I _{Δn})	30, 50, 100, 300 mA
Rated residual non-operating current	0.5 I _{Δn}
Rated residual making and breaking capacity	2000 A
Tripping time	≤ 0.1 s
Mechanical life	4000 operations
Electrical life	4000 operations
Tripping curves	B, C, D
Degree of protection	IP20
Overvoltage category	III
Standards	IEC 61009-1, GB/T 16917.1
Certification	CCC

Tripping characteristics (Reference temperature 30°C)

Item	Tripping Curve	Test current I _n (A)	Initial Status	Time limit for tripping or non-tripping	Expected result	Remarks
Delay	≤63	Cold	1.13I _n	≤1h	Non-tripping	
Delay	≤63	Following previous test	1.45I _n	<1h	Tripping	Current smoothly rises to specified value in 5s
Delay	≤32	Cold	2.55I _n	1<t<60s	Tripping	
Delay	>32	Cold	2.55I _n	1<t<120s	Tripping	
Instantaneous	Any value	Cold	3, 5, 10I _n	≤0.1s	Non-tripping	B, C, D
Instantaneous	Any value	Cold	5, 10, 20I _n	<0.1s	Tripping	B, C, D

Note: The term "cold" means that the test is carried out at a reference calibration temperature without load before the test.

Tripping curves

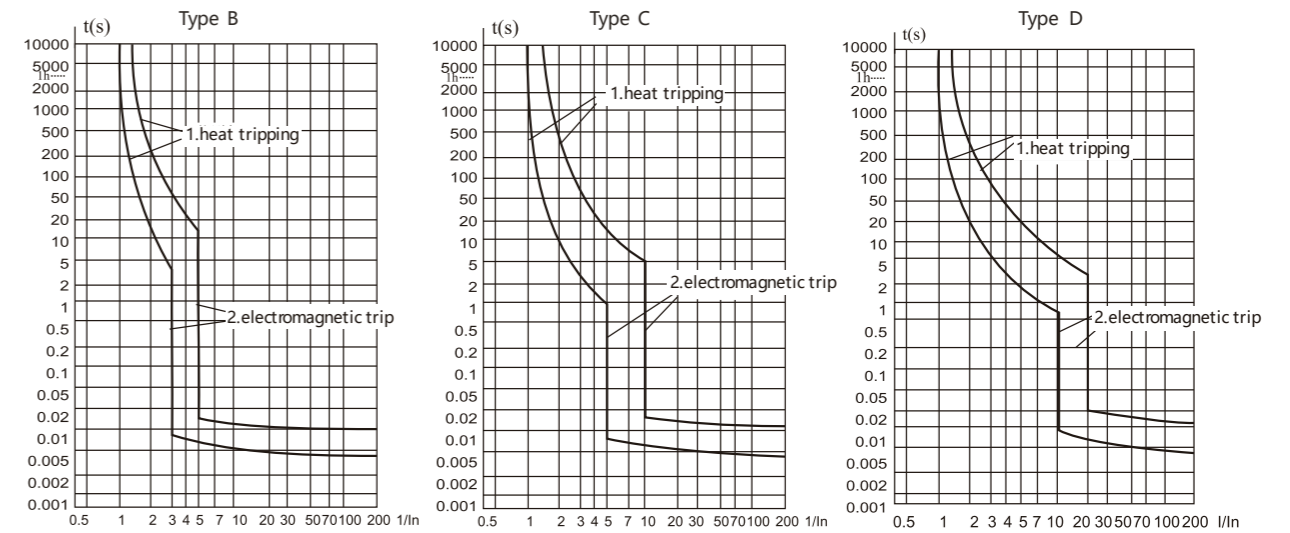

Conductor requirements and cross section

Copper cross-section(mm ²)	Rated current I _n (A)
1	I _n ≤6
1.5	6 < I _n ≤13
2.5	13 < I _n ≤20
4	20 < I _n ≤25
6	25 < I _n ≤32
10	32 < I _n ≤50
16	50 < I _n ≤63

Dimensions(mm)

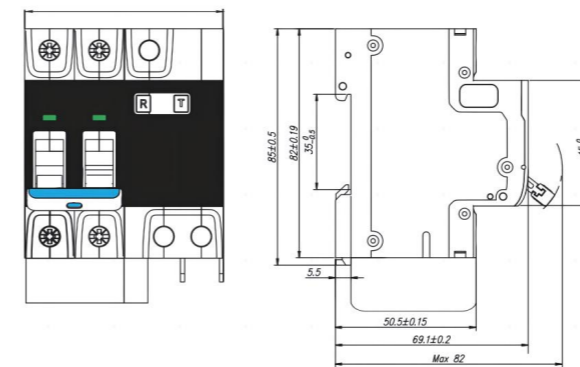

Poles	L
1P+N	53.4
2P	71.2
3P	102.4
3P+N	115.8
4P	133.6

Ordering Specification

- 1.Product Model: CQB3LE-63
 - 2.Number of Poles: 1P+N, 2P, 3P, 3P+N, 4P
 - 3.Rated Current & Tripping Curve: [e.g.: C/32A]
 - Tripping Curve: B, C, D
 - Rated Current (I_n): 6A, 10A, 16A, 20A, 25A, 32A, 40A, 50A, 63A
 - 4.Rated Residual Operating Current (I_{Δn}): 30mA, 50mA, 100mA, 300mA
 - 5.Quantity: [e.g.: 100 pcs]
- Ordering Example:
CQB3LE-63 2P C/32A 30mA 100 pcs

CQB3Ln-63

Residual Current Circuit Breaker with Overcurrent Protection - Electronic Type



Product Features

- Earth Leakage Protection
30/50/100/300mA sensitivity options provide personal protection against electric shock
- Dual Protection Function
Combines overload/short-circuit protection with earth leakage protection
- Fast Response
≤0.1s tripping time for quick fault circuit interruption
- Flexible Configurations
1P+N, 2P, 3P, 3P+N and 4P versions available

Type designation

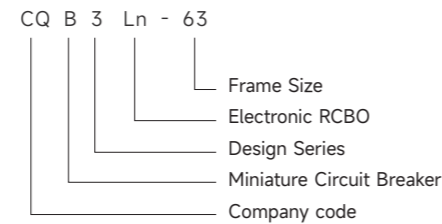

Technical Specifications

Parameter	
Rated Current (In)	6A, 10A, 16A, 20A, 25A, 32A, 40A, 50A, 63A
Rated Voltage	230V~
Rated Frequency	50/60Hz
Rated Breaking Capacity	6kA
Tripping Type	Thermal-magnetic (for overload and short-circuit)
Residual Current Operating Characteristic	AC, A
Rated Residual Operating Current ((IΔn)	30mA
Rated Residual Non-Operating Current ((IΔno)	15mA
Instantaneous Tripping Type	B, C
Number of Poles	1P+N
Rated Impulse Withstand Voltage (Uimp)	4kV (1.2/50 μs wave)
Power Frequency Withstand Voltage Test	2kV for 1 minute
Thermal Tripping Characteristic	(1.13-1.45) x In
Magnetic Tripping Characteristic	B: (3-5) x In, C: (5-10) x In
Electrical Endurance	6,000 cycles
Mechanical Endurance	10,000 cycles
Contact Position Indicator	Yes
Degree of Protection	IP20
Ambient Temperature	-25°C to +40°C, max. humidity 95%
Maximum Cable Terminal Size	16mm ²
Maximum Tightening Torque	2.5 N.m
Mounting Method	Mounts on 35mm DIN rail
Standard	IEC/EN 61009-1

Tripping curves

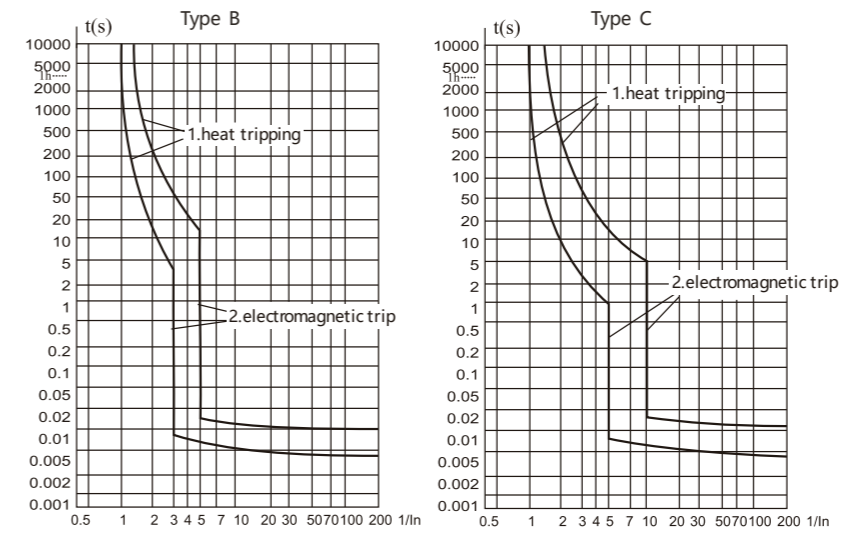

Conductor requirements and cross section

Copper cross-section(mm ²)	Rated current In(A)
1	In≤6
1.5	6 < In≤13
2.5	13 < In≤20
4	20 < In≤25
6	25 < In≤32
10	32 < In≤50
16	50 < In≤63

Dimensions(mm)

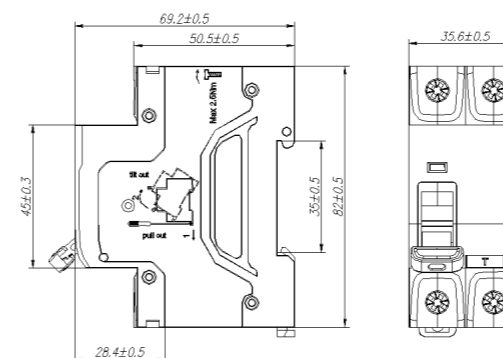

Ordering Specification

- 1.Product Model: CQB3Ln-63
 - 2.Number of Poles: 1P+N,
 - 3.Rated Current & Tripping Curve: [e.g.: C/32A]
 - Tripping Curve: B, C,
 - Rated Current (In): 6A, 10A, 16A, 20A, 25A, 32A, 40A, 50A, 63A
 - 4.Rated Residual Operating Current (IΔn): 30mA,
 - 5.Quantity: [e.g.: 100 pcs]
- Ordering Example:
CQB3Ln-63 1P+N C/32A 30mA 100 pcs

CQB3GQ-80

Self-restoring Over-under Voltage Protector



Product Features

- **Wide Application Range**
Suitable for single-phase AC 230V, 50Hz systems with rated current up to 80A, protecting against neutral line faults.
- **Automatic Recovery Function**
Automatically reconnects circuit within specified time (30s±10s) when voltage returns to normal, ensuring continuous operation without manual intervention.
- **Intelligent Voltage Protection**
Utilizes high-speed micro low-power processor and magic holding relay to quickly cut off power during over/undervoltage conditions, preventing damage to terminal equipment.

Type designation

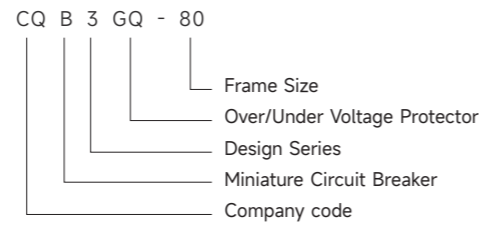

Technical Specifications

Parameter	
Rated Voltage	AC 230V
Rated Frequency	50 Hz
Rated Current	40A, 63A, 80A
Poles	1P+N
Overvoltage Tripping Value	AC 270V±5V
Undervoltage Tripping Value	AC 170V±5V
Delay Time	30s±10s
Mechanical & Electrical Life	≥100,000 operations
Terminal Torque	2-3 Nm
Pollution Degree	Level 2
Degree of Protection	IP20
Standard	JB/T12762

Dimensions(mm)

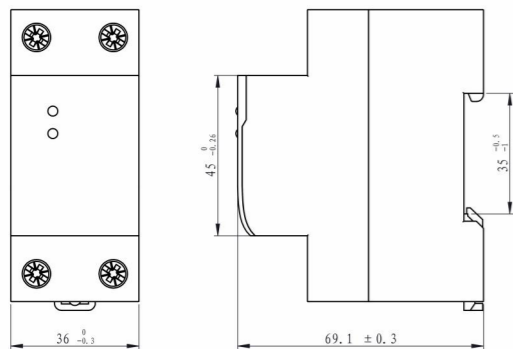

Ordering Specification

- 1.Product Model: CQB3GQ-80
 - 2.Number of Poles: 1P+N
 - 3.Rated Current: 40A, 63A, 80A
 - 4.Quantity: [e.g.: 100 pcs]
- Ordering Example:
CQB3GQ-80 1P+N 63A 100 pcs

ExS-T1T2-AC

Surge Protective Device



Product Features

- 10/350µs,8/20µs sparkgap
- Single-pole lightning current arrester, pluggable
- Adopt hermetical GDT technology, high follow current extinguishing capability
- Extremely low voltage protection level
- Double terminals for parallel or series(V-shape) connection
- Multifunctional connection for conductors and busbars
- Green window will change to red when fault occurs, also provide remote alarm terminal at the same time
- For using high-performance MOV and maximum will up to 10/350 7kA

Technical Specifications

Parameter	
Rated voltage (max. continuous AC voltage)	275V or 385V
Lightning impulse current (10/350) [Iimp]	7 kA
Nominal discharge current (8/20) [In]	20 kA
Maximum discharge current [Imax]	50 kA
Voltage protection level [Up]	≤ 1.5 kV
Follow current extinguishing capability at Uc	32A fuse will not be triggered at 2kA...255V
Response time [t]	≤ 100 ns
Max. backup fuse (L)	200A gL/gG
Max. backup fuse (L-L')	125A gL/gG
TOV voltage	355V / 5sec
Operating temperature range (parallel wiring)	-40°C to +80°C
Operating temperature range (through wiring)	-40°C to +60°C
Terminal cross-sectional area	35 mm ² solid / 50 mm ² flexible
Mounting	on 35mm DIN rail
Enclosure material	Purple (module)/light gray (base) thermoplastic, UL94-V0
Dimension	2 modules
Type of remote signalling contact	Switching contact
Switching capacity AC	250V / 0.5A
Switching capacity DC	250V / 0.1A; 125V / 0.2A; 75V / 0.5A
Cross-sectional area for remote signalling contact	Max. 1.5 mm ² solid/flexible
Standards	IEC 61643-11; GB 18802.1; YD/T 1235.1
Certification	CE, RoHS, ISO 9001, CQC, TUV

Dimensions(mm)

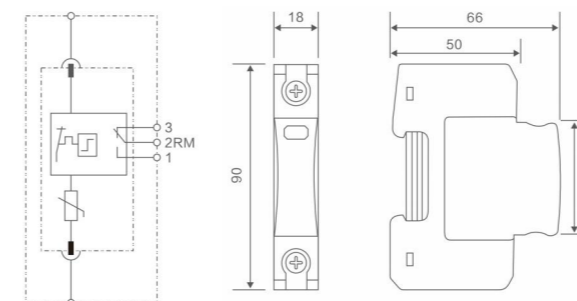

FB2-63

Miniature Circuit Breaker



Product Features

- Enhanced Arc Extinguishing**
 Utilizes a 13-grid arc chute combined with a superimposed arc starter to rapidly improve arc extinguishing capability and breaking performance.
- Safe and Reliable Connection**
 Features large wiring terminals with a anti-misinsertion design, ensuring secure connections and preventing loose wires.
- Robust Circuit Protection**
 Provides reliable overload and short-circuit protection with a rated breaking capacity of 6kA, complying with IEC 60898-1 standards.

Type designation

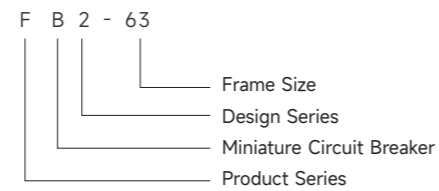

Tripping curves

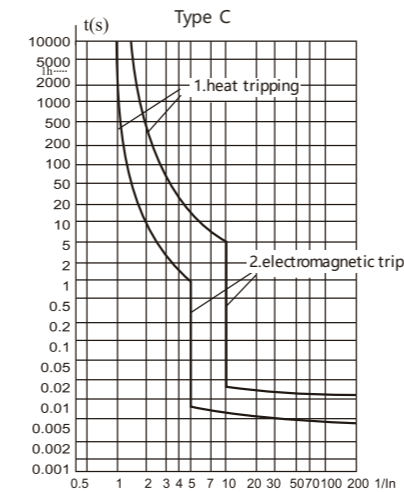

Dimensions(mm)

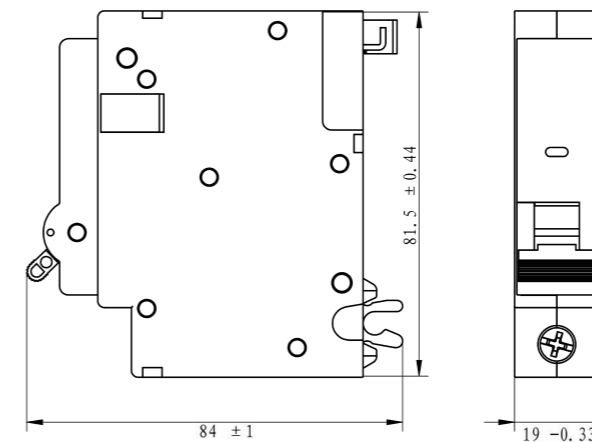

Ordering Specification

- Product Model: FB2-63
 - Number of Poles: 1P, 2P
 - Tripping Curve & Rated Current: [e.g.: C/32A]
 - Tripping Curve: C
 - Rated Current (In): 10A, 16A, 20A, 25A, 32A, 40A, 50A, 63A
 - Quantity: [e.g.: 100 pcs]
- Ordering Example:
 FB2-63 2P C/32A 100 pcs

Technical Specifications

Parameter	
Bracket rating current	63A
Number of poles	1P, 2P
Feature	Overload and short circuit protection
Rated frequency f(HZ)	50/60Hz
Rated operating voltage Ue(V AC)	240V ~
Rated current In(A)	10, 16, 20, 25, 32, 40, 50, 63A
Rated insulation voltage Ui(V)	500V
Rated impulse withstand voltage Uimp(kV)	4kV
Rated operating short-circuit breaking capacity (kA)	6kA
Rated limit short-circuit breaking capacity (kA)	6kA
Current limiting class	3
Instantaneous trip characteristics	Electromagnetic type
Trip type	C
Electrical service life	4000 times
Service life of machinery	10000 times
Class of protection	IP20
Wiring capability (mm ²)	1 to 16mm ²
Ambient temperature (daily average temperature °C)	35 °C or less
Storage temperature	-25°C to +55°C
Types of climate protection	Damp-heat type
Altitude (m)	≤2000m
Relative humidity of air	50% ~ 90%
Pollution level	2
Installation environment	/
Installation category	II or III
Installation mode	plug-in
Meet the standard	IEC 60898-1

FB2H-63

Miniature Circuit Breaker



Product Features

- Enhanced Arc Extinguishing**
 Utilizes a 13-grid arc chute combined with a superimposed arc starter to rapidly improve arc extinguishing capability and breaking performance.
- Safe and Reliable Connection**
 Features large wiring terminals with an anti-misinsertion design, ensuring secure connections and preventing loose wires.
- Wide Application Adaptability**
 Designed for plug-in installation with IP20 protection class, suitable for environments up to 2000m altitude and ambient temperature $\leq 35^{\circ}\text{C}$.

Type designation

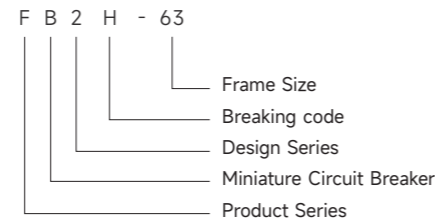

Technical Specifications

Parameter	
Bracket rating current	63A
Number of poles	1P, 2P
Feature	Overload and short circuit protection
Rated frequency f(HZ)	50/60Hz
Rated operating voltage Ue(V AC)	240V ~
Rated current In(A)	10, 16, 20, 25, 32, 40, 50, 63A
Rated insulation voltage Ui(V)	500V
Rated impulse withstand voltage Uimp(kV)	4kV
Rated operating short-circuit breaking capacity (kA)	7.5 kA
Rated limit short-circuit breaking capacity (kA)	10kA
Current limiting class	3
Instantaneous trip characteristics	Electromagnetic type
Trip type	C
Electrical service life	4000 times
Service life of machinery	10000 times
Class of protection	IP20
Wiring capability (mm ²)	1 to 25mm ²
Ambient temperature (daily average temperature °C)	35 °C or less
Storage temperature	-25°C to +55°C
Types of climate protection	Damp-heat type
Altitude (m)	$\leq 2000\text{m}$
Relative humidity of air	50% ~ 90%
Pollution level	2
Installation environment	/
Installation category	II or III
Installation mode	plug-in
Meet the standard	IEC 60898-1

Tripping curves

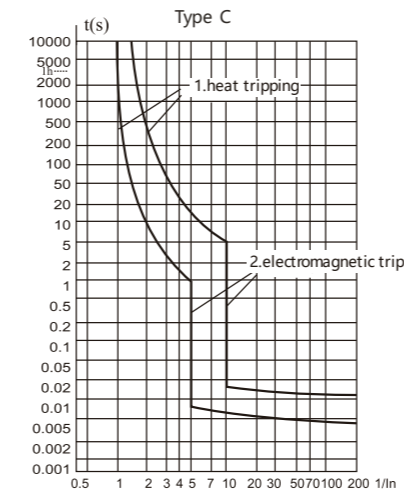

Dimensions(mm)

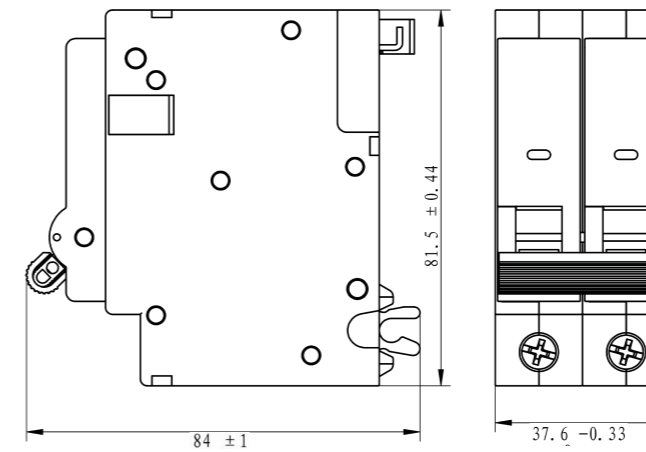

Ordering Specification

- Product Model: FB2H-63
 - Number of Poles: 1P, 2P
 - Tripping Curve & Rated Current: [e.g.: C/32A]
 - Tripping Curve: C (Electromagnetic)
 - Rated Current (In): 10A, 16A, 20A, 25A, 32A, 40A, 50A, 63A
 - Quantity: [e.g.: 100 pcs]
- Ordering Example:
FB2H-63 2P C/32A 100 pcs

FB2L-63

Residual Current Circuit Breaker with Overcurrent Protection - Electromagnetic Type



Product Features

- Compact Space-Saving Design
Features small size for efficient use of distribution box space while maintaining full functionality.
- Safe Wiring System
Equipped with anti-misinsertion terminal design and small wiring ports to prevent incorrect cable connections.
- Wide Application Compatibility
Suitable for various environments (up to 2000m altitude, -25°C to +55°C storage temperature) with IP20 protection and plug-in installation.

Type designation

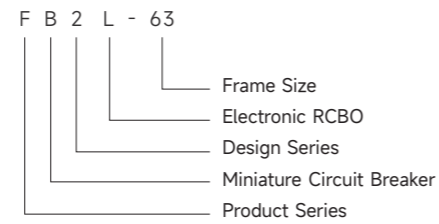

Technical Specifications

Parameter	
Bracket rating current	50A
Number of poles	1P+N
Feature	Overload and short circuit protection
Rated frequency f(HZ)	50/60Hz
Leakage trip mode	Electronic formula
Leakage type	Type AC
Rated operating voltage Ue(V AC)	240V ~
Rated current In(A)	10, 16, 20, 25, 32, 40, 50A
Rated insulation voltage Ui(V)	500V
Rated impulse withstand voltage Uimp(kA)	4kV
Rated residual current IΔn	30mA
Rated remaining making and breaking capacity IΔm	2000A
Rated operating short-circuit breaking capacity (kA)	6kA
Rated limit short-circuit breaking capacity (kA)	6kA
Current limiting class	3
Instantaneous trip characteristics	Electromagnetic type
Trip type	C
Electrical service life	4000 times
Service life of machinery	10000 times
Class of protection	IP20
Wiring capability (mm ²)	1 to 16mm ²
Ambient temperature (daily average)	35 °C or less
Storage temperature	-25°C to +55°C
Types of climate protection	Damp-heat type
Altitude (m)	≤2000m
Relative humidity of air	50% ~ 90%
Pollution level	2
Installation environment	B
Installation category	II or III
Installation mode	plug-in
Meet the standard	IEC 61009-1

Tripping curves

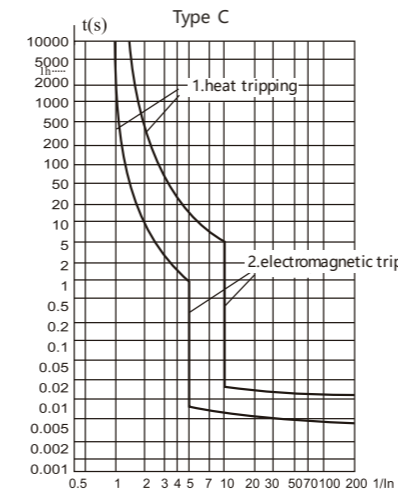

Dimensions(mm)

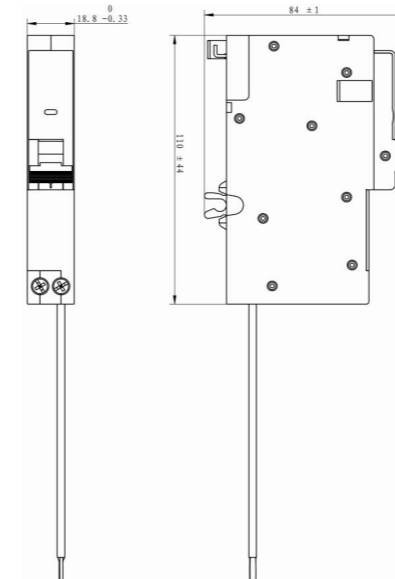

Ordering Specification

- 1.Product Model: FB2L-63
 - 2.Number of Poles: 1P+N
 - 3.Rated Current: [e.g.: 32A]
 - Rated Current (In): 10A, 16A, 20A, 25A, 32A, 40A, 50A
 - 4.Residual Operating Current: 30mA
 - 5.Quantity: [e.g.: 100 pcs]
- Ordering Example:
FB2L-63 1P+N 32A 30mA 100 pcs

FB2HL-63

Residual Current Circuit Breaker with Overcurrent Protection - Electromagnetic Type



Product Features

- Compact Space-Saving Design
Features small dimensions for efficient use of distribution box space while maintaining full functionality.
- Dual Protection Performance
Combines overload/short-circuit protection (7.5kA operational/10kA limit breaking capacity) with earth fault protection
- User-Friendly Design
Test button for regular safety checks and large wiring terminals with anti-misinsertion design

Type designation

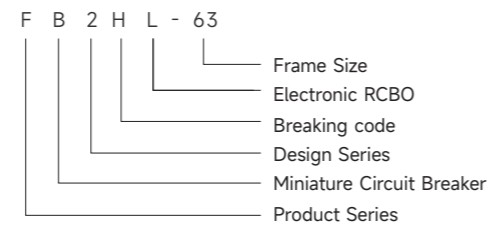

Technical Specifications

Parameter	
Bracket rating current	50/63A
Number of poles	1P+N/2P
Feature	Overload and short circuit protection
Rated frequency f(HZ)	50/60Hz
Leakage trip mode	Electronic formula
Leakage type	Type AC
Rated operating voltage Ue(V AC)	240V ~
Rated current In(A)	10, 16, 20, 25, 32, 40, 50, 63A
Rated insulation voltage Ui(V)	500V
Rated impulse withstand voltage Uimp(kA)	4kV
Rated residual current IΔn	30mA
Rated remaining making and breaking capacity IΔm	2000A
Rated operating short-circuit breaking capacity (kA)	7.5 kA
Rated limit short-circuit breaking capacity (kA)	10kA
Current limiting class	3
Instantaneous trip characteristics	Electromagnetic type
Trip type	C
Electrical service life	4000 times
Service life of machinery	10000 times
Class of protection	IP20
Wiring capability (mm ²)	1 to 25mm ²
Ambient temperature (daily average)	35 °C or less
Storage temperature	-25°C to +55°C
Types of climate protection	Damp-heat type
Altitude (m)	≤2000m
Relative humidity of air	50% ~ 90%
Pollution level	2
Installation environment	B
Installation category	II or III
Installation mode	plug-in
Meet the standard	IEC 61009-1

Tripping curves

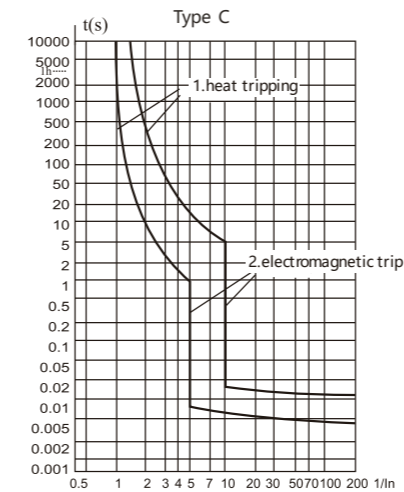

Dimensions(mm)

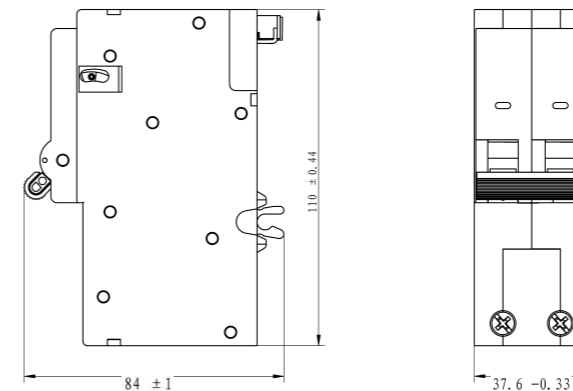

Ordering Specification

- 1.Product Model: FB2HL-63
 - 2.Number of Poles: 1P+N or 2P
 - 3.Rated Current: [e.g.: 32A]
 - Rated Current (In): 10A, 16A, 20A, 25A, 32A, 40A, 50A, 63A
 - 4.Residual Operating Current: 30mA
 - 5.Quantity: [e.g.: 100 pcs]
- Ordering Example:
 FB2HL-63 1P+N 32A 30mA 100 pcs

CQL14

Electromagnetic Residual Current Operated Circuit Breaker



Product Features

- Fully Electromagnetic & Highly Reliable
- Fast Tripping for Safety
- High Short-Circuit Withstand Capability
- Broad Compatibility & Flexible Options
- Standards Compliant & Durable Construction

Type designation



Dimensions(mm)

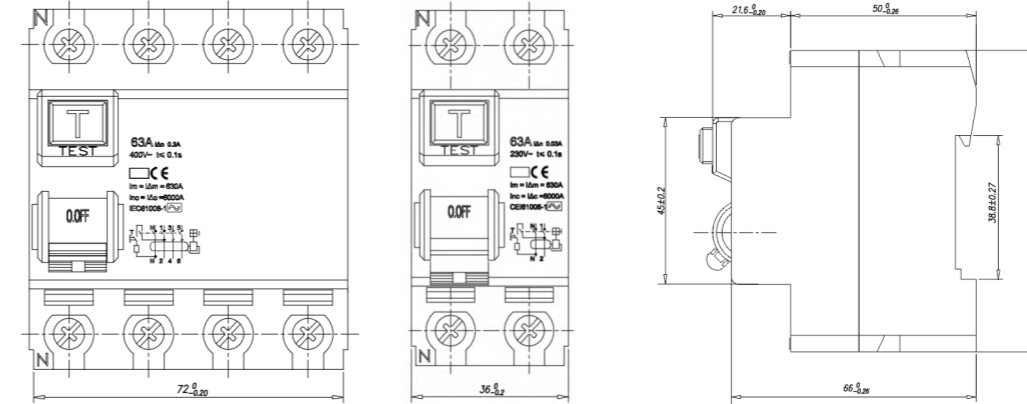

Technical Specifications

Parameter	
Rated Voltage	230V AC(1P+N);400V AC(3P+N)
Rated Current (A)	25A、40A、63A、80A、100A
Rated Residual Operating Current	0.03A、0.1A、0.3A
Rated Residual Non-Operating Current	0.5I Δ n
Type of Residual Current (with DC component)	AC type、A type(In=25、40、63A)
Number of Poles	1P+N、3P+N
Rated Conditional Short-Circuit Current	6000A
Rated Conditional Residual Short-Circuit Current	6000A
Rated Making and Breaking Capacity	500A (In=25、40A) ; 10In (63、80、100A)
Rated Residual Making and Breaking Capacity	500A (In=25、40A) ; 10In (63、80、100A)
Tightening Torque	(2.5 ~ 3.0) N.m
Protection Class	IP20
Pollution Degree	2
Installation Category	II
Standards	GB 16916.1, IEC61008-1

Break time for residual current

I _n (A)	I Δ n (A)	Breaking time when the residual current equals the following values (s)				
		I Δ n	2I Δ n	5I Δ n	5A、10A、20A、50A、100A、200A	I Δ t
25 ~ 100A	0.03、0.1、0.3	0.1	0.05	0.04	0.04	0.04

Mechanical and electrical endurance

I _n (A)	Number of operating cycles		Operating frequency (cycles per hour)
	Number of on-load operating cycles	Number of no-load operating cycles	
25A	2000	4000	240
40A、63A、80A、100A	2000	4000	120

CQB58

Safety Breaker



Product Features

- Industrial-Grade Protection
 - 1.5kA high breaking capacity ensures reliable short-circuit interruption
 - Thermal overload protection (1.13-1.45×I_n) prevents equipment damage
- Multi-Current Versatility
 - 5 current ratings: 10A/15A/20A/30A/40A for flexible load matching
- Robust Construction
 - IP20 isolation protection with 2kV dielectric strength
 - Top-entry terminals support ≤10mm² cables (2N·m torque)
- Wide Application
 - Designed for industrial/commercial buildings, high-rises, and residences
- Environmental Adaptability
 - Operates at -5°C~+40°C with ≤90% humidity

Type designation

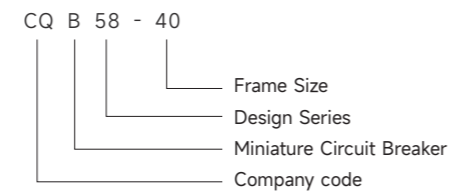

Dimensions(mm)

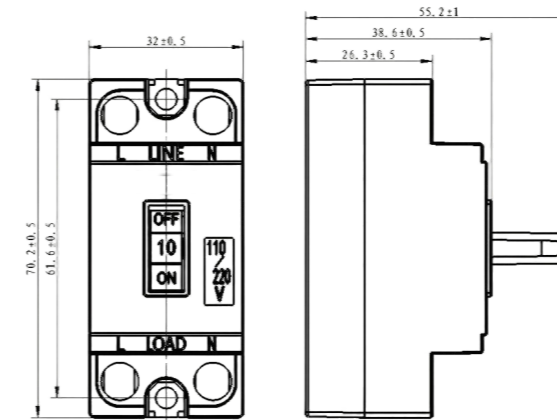

Ordering Specification

Please specify the following when ordering:
 Product Model: CQB58
 1.Model & Current: ZN58-[Current]
 • Current options: 10A / 15A / 20A / 30A / 40A
 2.Number of Poles: 2P1E (fixed configuration)
 3.Quantity: [e.g. 100 units]
 Ordering Examples:
 CQB58-20A 100 pcs

Technical Specifications

Parameter	
Standard	IEC/EN60898-1
Protection	Overload protection
Type of trip	Overload :Thermal
No.of poles	2P1E
Rated currents(I _n)	10A/15A/20A/30A/40A
Rated voltage	230V
Rated frequency	50/60Hz
Rated Short-Time Current	1.5kA
Dielectric test voltage at Ind. Freq.for 1 min	2kV
Thermal release characteristic	(1.13-1.45) x I _n
Electrical life	4,000 Cycles
Protection degree	IP20
Ambient temperature	-5°C to +40°C, Max.90% humidity
Terminal connection type	Cable
Max. cable cross-section	10mm ²
Max. tightening torque	2N.m
Connection	From top

CQGQA-63

Over/Under Voltage & Over-Current Auto-Reclosing Protector



Product Features

- Intelligent Integrated Protection**
 Integrates over-voltage, under-voltage, and over-current protection. Cuts off power instantly upon fault to safeguard equipment.
- Automatic Power Recovery**
 Automatically restores power after a preset delay once line conditions normalize, requiring no manual intervention.
- High Reliability**
 Immune to transient or temporary over-voltage, preventing nuisance tripping and unnecessary power outages.
- Customizable Settings**
 All protection values, reset values, and delay times can be flexibly adjusted according to actual needs.
- Safety Delay**
 Features an adjustable delay before re-connection in case of unstable voltage or sudden power restoration, ensuring safety.

Type designation

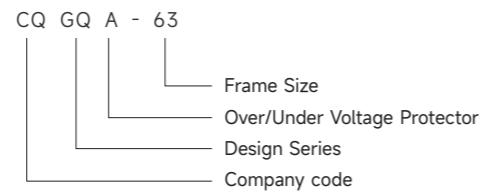

Dimensions(mm)

1P+N 40A/63A

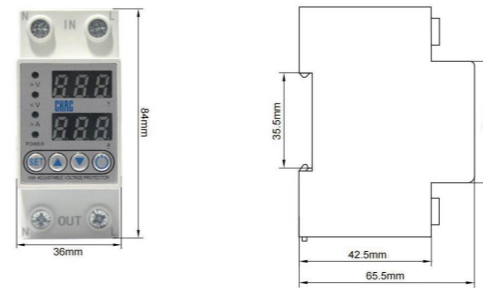

1P+N 80A/100A

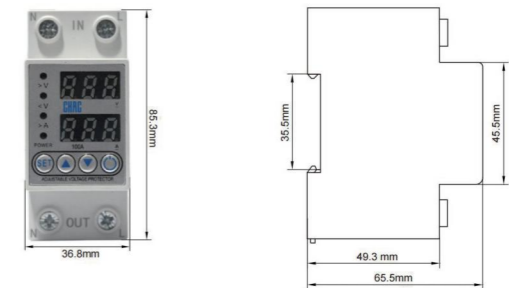

3P+N 63A

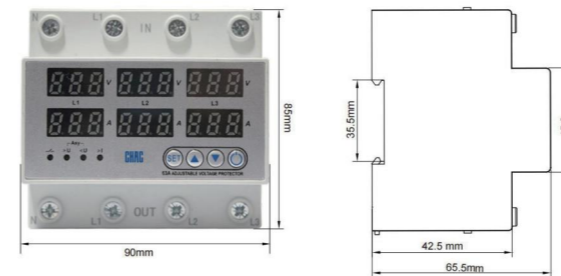

3P+N 100A

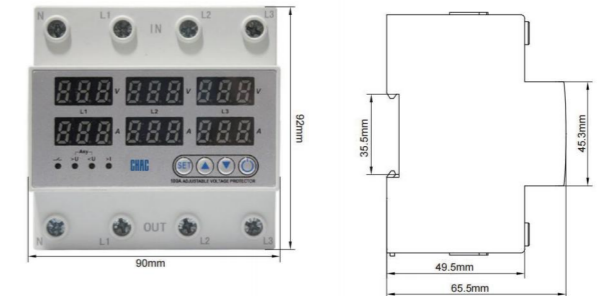

Technical Specifications

Parameter	
Number of Poles	1P+N, 3P+N
Rated Operational Voltage	AC220V
Rated Operational Current	1-40A Adjustable (Default 40A), 1-63A Adjustable (Default 63A), 1-80A Adjustable (Default 80A), 10-100A Adjustable (Default 100A)
Rated Operational Frequency	50Hz/60Hz
Over-voltage Trip Value	240V-300V Adjustable (Default 270V)
Over-voltage Reset Value	235V-295V AC Adjustable (Start from 5V below Trip Value, Default 265V)
Under-voltage Trip Value	140V-200V Adjustable (Default 170V)
Under-voltage Reset Value	145V-205V AC Adjustable (Start from 5V above Trip Value, Default 175V)
Over-current Trip Value	40A: 1-40A Adj. (Def 40A); 63A: 1-63A Adj. (Def 63A); 80A: 1-80A Adj. (Def 80A); 100A: 10-100A Adj. (Def 100A)
Power-on & Post-outage Delay Time	1-300s Adjustable (Default 5s)
OV/UV Protection Reset Delay Time	5-300s Adjustable (Default 30s)
Over-current Protection Reset Delay Time	30-300s Adjustable (Default 30s)
Over-current Detection Delay Time	6s (An over-current condition lasting longer than this time will be confirmed and protected)
Electrical & Mechanical Life	>100,000 cycles
Mounting Method	Standard Din-Rail Mounting

CQGQS-63

WiFi Smart Circuit Breaker Protector



Product Features

- Real-time LCD Monitoring
Backlit display shows live grid voltage, current, leakage, and energy consumption with State Grid-grade precision.
- Fully Adjustable Protection
Customizable undervoltage, overvoltage, overcurrent, and leakage protection with cumulative power monitoring.
- Smart Remote Control
Mobile app enables remote ON/OFF switching, real-time parameter configuration, and monitoring from anywhere.
- Auto-reclose & Energy Tracking
Automatic circuit restoration after faults; daily energy tracking with manual/midnight reset for billing.

Type designation

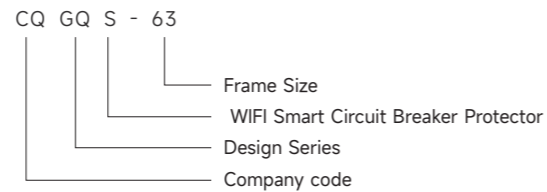

Technical Specifications

Parameter	
Rated Voltage	220V
Rated Current	63A
Rated Frequency	50/60Hz
Inductive Load	6KW (Motor type)
Resistive Load	13KW (Electric heating and lighting)
Power Consumption	<2W
Ambient Temperature	-25°C to 65°C
Humidity	<95%
Installation Method	DIN Rail Mounting
Control Mode	Manual / Mobile Remote
Undervoltage Setting	230V-300V, adjustable in 1V steps
Overvoltage Setting	110V-210V, adjustable in 1V steps
Overcurrent Setting	1A-63A, adjustable in 1A steps
Leakage Current Setting	10mA-100mA, adjustable in 1mA steps
Delay Setting	1s-999s, adjustable in 1s steps
Voltage Display Accuracy	1V
Current Display Accuracy	0.1A
Leakage Display Accuracy	1mA
Energy Display Accuracy	0.1 kWh

Wiring diagram

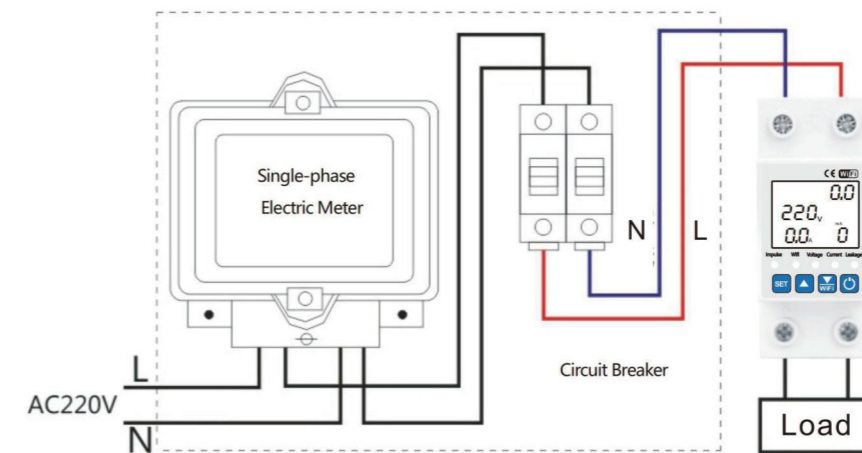

Dimensions(mm)

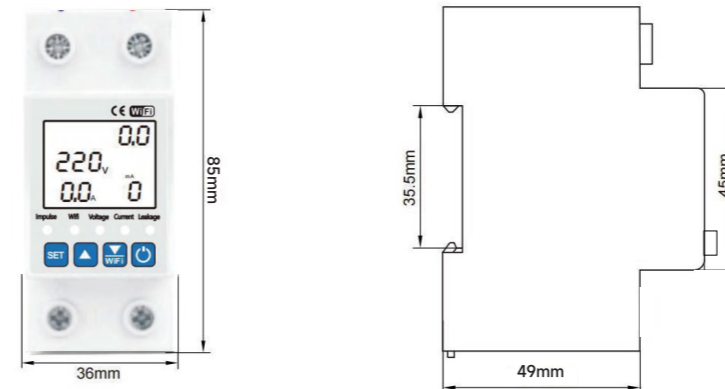

CQGQE

WiFi Din Rail Switch (Tuya APP)



Product Features

- Controla el interruptor desde cualquier lugar con la APP Tuya Smart o mediante comandos de voz (Alexa, Google Assistant).
- Incluye protección contra sobrecorriente, sobretensión/subtensión y fugas para mayor seguridad.
- Programa encendido/apagado automático (diario/semanal) y monitoriza el consumo en tiempo real.
- Recibe nuevas funciones y mejoras automáticamente a través de actualizaciones por aire.

Type designation

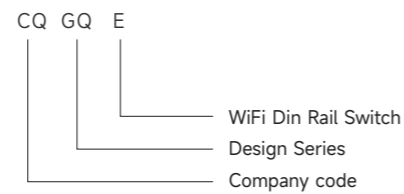

Technical Specifications

Parameter	
Poles description	1P+N(N pole Pass-through)
Rated operating voltage range	90-300V
Control type	Manual,Remote control APP
Protocol	Wifi(Default)
Customization	SigMesh/ZigBee

1.LED Indicator Description

- The LED indicator show a steady blue light to indicate that the switch in ON status.
- The LED indicator show a light off to indicate that the switch in OFF status. (In off grid mode,there is no light in dicating,switch shall carefully operated to keep safety)
- The LED indicator show blue flashing to indicate that switch in parting model.

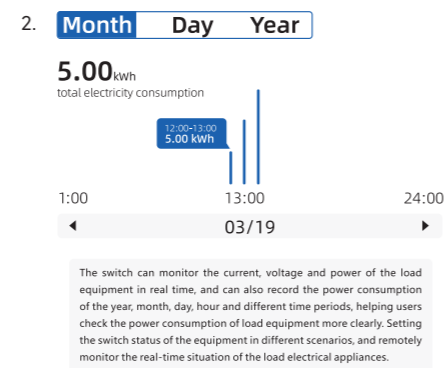

First Step:

Connect the wire from upper of the switch,the live wire connect to the L pole,and the neutral wire connect to the N pole.Please make sure the wiring is correct and with stron WIFI signal.Then scan the APP QR code to download and register.



Second Step:

Turn on the Bluetooth and WIFI of the mobile phone,open the APP,and long press the "power"button,wait for about 5-10 seconds,the LED indicator will flash blow light slowly.Then wait in Tuya interface.

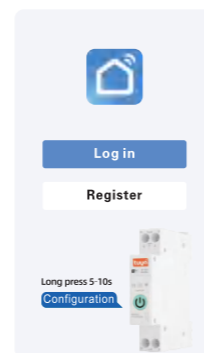

Third Step:

Waiting for a while after Tuya display the APP or click "+" in the upper right corner,and wait to discover devices. Then click "Add" button.

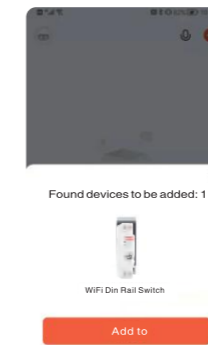

Fourth Step:

Enter wifi account and password and click next step,wait switch to connect to the network.

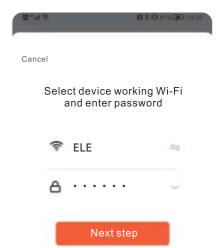

Fifth Step:

After successful connection,the LED indicator will change from blue slow flashing to blue steady light.

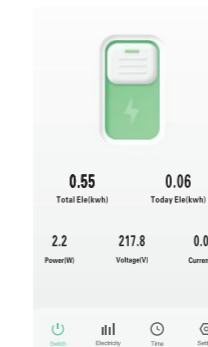

Timing function

Timing types could be selected accordingly.

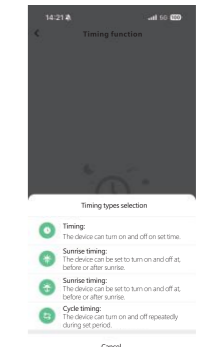

Alarm protection setting(adjustable)

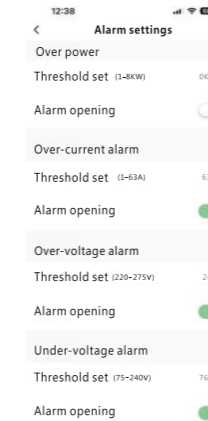
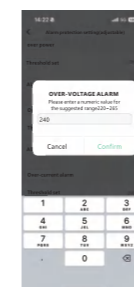

Device share

First Step:

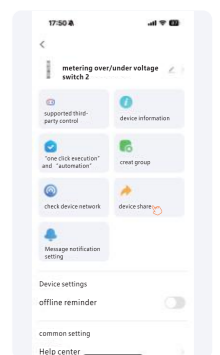
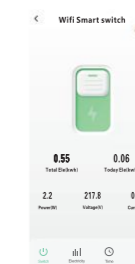

Device Sharing

Second Step:

Click on "share with the Account Smart Life" to type the account you want to share.

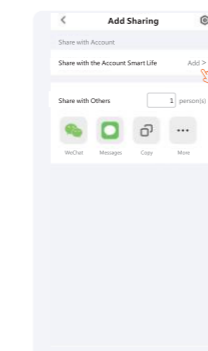

Download APP



CQMG10 Series

Plug-In Distribution Box



Product Features

- Plug-in Design: Enables quick and easy installation of circuit breakers.
- Robust Construction: Box made from cold-rolled steel; visible cover in high-impact PC material.
- Versatile Configurations: Available in 4, 6, 10, and 12-circuit versions with main switch (2P).
- Full Compatibility: Pre-punched knockouts (Φ32/Φ25) and dedicated N/PE terminal holes simplify wiring.
- Surface Mounting: Designed for straightforward and flexible installation.
- Protection Rating: IP20 for mounting holes, IP40 for other parts (before knockout removal).

Type Designation

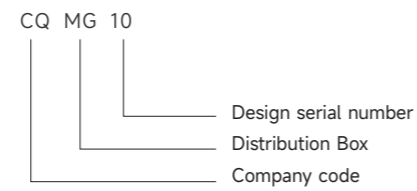

Technical Specifications

Parameter	Description
Mounting Type	Surface Mount
Material	Box: Cold-rolled steel Cover: PC material
Plate Thickness	1.0 mm
Circuit Breaker Type	Plug-in
Protection Rating	IP20 (for mounting holes) IP40 (for other parts, before knockout removal)
Surface Treatment	Electrostatic spraying

Dimensions(mm)

Circuit Configuration	Box Dimensions (LWD, mm)	Neutral Bar Terminal Holes	Ground Bar Terminal Holes	Knockouts
Main Switch (2P) + 4 Circuits	249 * 209 * 105	4	7	Top: Φ32×2 + Φ25×2 Bottom: Φ32×2 + Φ25×2
Main Switch (2P) + 6 Circuits	249 * 208 * 105	6	9	Top: Φ32×2 + Φ25×2 Bottom: Φ32×2 + Φ25×2
Main Switch (2P) + 10 Circuits	326 * 209 * 105	10	13	Top: Φ32×2 + Φ25×2 Bottom: Φ32×2 + Φ25×2
Main Switch (2P) + 12 Circuits	364 * 209 * 105	12	15	Top: Φ32×2 + Φ25×2 Bottom: Φ32×2 + Φ25×5

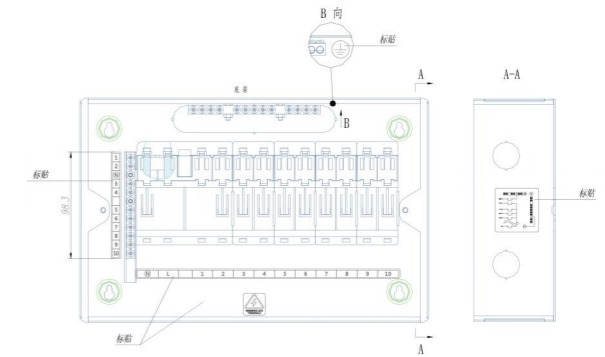
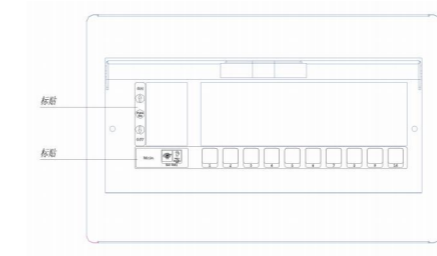

Ordering Specification

Please specify the following when ordering:

- 1.Product Model: CQMG10
- 2.Quantity: [e.g.: 100 pcs]

Ordering Example:

CQMG10 100 pcs

CQMG20A Series

Distribution Box



Product Features

- Large PC Panel
High-strength, full-coverage panel that is fire-resistant, flame-retardant, and impact-resistant.
- Snap-lock Terminal Blocks
Large-wire-entry design for stable, quick wiring without damaging conductors.
- Adjustable Mounting Rails
Vertically and horizontally adjustable for easy alignment and installation of modules.
- Built-in Spirit Level
Integrated in the box for easy horizontal alignment, simplifying installation.
- Flexible Color Options
Face cover available in White or Transparent Tea color variants.

Type Designation

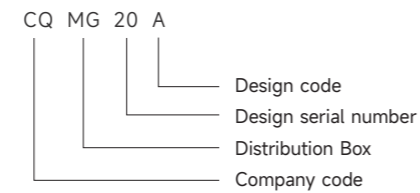

Technical Specifications

Model Number	Base Box Material	Color Option	Installation Instructions	Overall Size	Mounting Size	Carton	Carton Size
CQMG20A-04M	Metal/ Plastic	White/ Tea Transparent	Surface Mounted	180×159×77.5(mm)	180×159×92(mm)	30pcs/carton	500×430×375(mm)
CQMG20A-07M	Metal/ Plastic	White/ Tea Transparent	Surface Mounted	240×213×80(mm)	240×213×95(mm)	10pcs/carton	530×445×270(mm)
CQMG20A-10M	Metal/ Plastic	White/ Tea Transparent	Surface Mounted	240×267×80(mm)	240×267×95(mm)	10pcs/carton	530×505×295(mm)
CQMG20A-14M	Metal/ Plastic	White/ Tea Transparent	Surface Mounted	240×339×80(mm)	240×339×95(mm)	8pcs/carton	505×425×370(mm)
CQMG20A-18M	Metal/ Plastic	White/ Tea Transparent	Surface Mounted	260×411×81.5(mm)	260×411×96.5(mm)	8pcs/carton	545×425×435(mm)
CQMG20A-22M	Metal/ Plastic	White/ Tea Transparent	Surface Mounted	260×483×81.5(mm)	260×483×96.5(mm)	8pcs/carton	545×425×510(mm)
CQMG20A-26M	Metal/ Plastic	White/ Tea Transparent	Surface Mounted	260×555×81.5(mm)	260×555×96.5(mm)	6pcs/carton	620×585×295(mm)

Installation Instructions

Surface Mounted

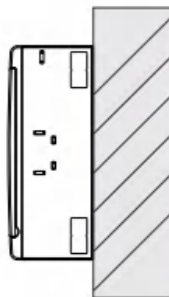

CQMG20B Series

Distribution Box



Product Features

- Flexible Installation
Available in both flush-mounted (recessed) and surface-mounted versions to suit various installation requirements.
- Functional Construction
Double-row layout offers ample internal space for easier wiring and component arrangement. Ensure stable, quick wire connections without nicking conductors.
- Multiple Models
Available in various sizes to accommodate different capacity needs.

Type Designation

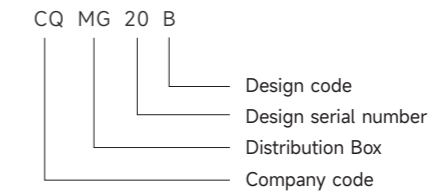

Technical Specifications

Model Number	Base Box Material	Color Option	Installation Instructions	Overall Size	Mounting Size	Carton	Carton Size
CQMG20B-28	Metal/ Plastic	White/ Tea Transparent	Flush Mounted	462×319×80(mm)	482×339×95(mm)	4pcs/carton	500×430×375(mm)
CQMG20B-36	Metal/ Plastic	White/ Tea Transparent	Flush Mounted	502×391×80(mm)	522×411×95(mm)	4pcs/carton	530×415×430(mm)
CQMG20B-44	Metal/ Plastic	White/ Tea Transparent	Flush Mounted	502×463×80(mm)	522×483×95(mm)	4pcs/carton	535×430×510(mm)
CQMG20B-52	Metal/ Plastic	White/ Tea Transparent	Flush Mounted	502×535×80(mm)	522×555×95(mm)	4pcs/carton	570×430×550(mm)
CQMG20B-28M	Metal/ Plastic	White/ Tea Transparent	Surface Mounted	482×339×80(mm)	482×339×95(mm)	4pcs/carton	500×430×375(mm)
CQMG20B-36M	Metal/ Plastic	White/ Tea Transparent	Surface Mounted	522×411×80(mm)	522×411×95(mm)	4pcs/carton	530×415×430(mm)
CQMG20B-44M	Metal/ Plastic	White/ Tea Transparent	Surface Mounted	522×483×80(mm)	522×483×95(mm)	4pcs/carton	535×430×510(mm)
CQMG20B-52M	Metal/ Plastic	White/ Tea Transparent	Surface Mounted	522×555×80(mm)	522×555×95(mm)	4pcs/carton	570×430×550(mm)

Installation Instructions

Flush Mounted

Surface Mounted

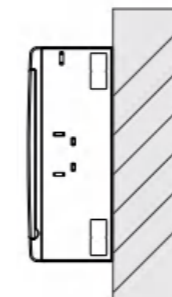

CQMG20C Series

Distribution Box

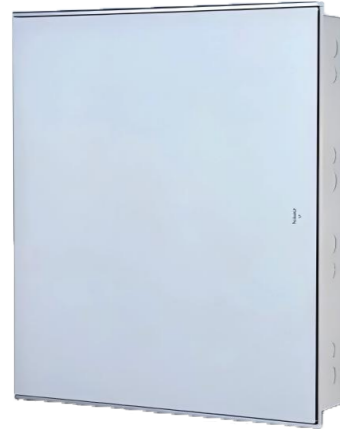

Product Features

- High-Strength Aluminum Alloy Frame
Guarantees a flush finish, corrosion resistance, and anti-deformation for long-term stability.
- Flexible Capacity Options
A wide range of models from 15 to 52 modules (single/double row) to meet various power requirements for apartments and residences.
- Integrated Power & Data Design
Dedicated models accommodate both power and data modules for centralized and neat management.
- Multiple Color Options
Available in Pearl White, Starlight Gray, and Translucent Black to match various interior styles.

Type Designation

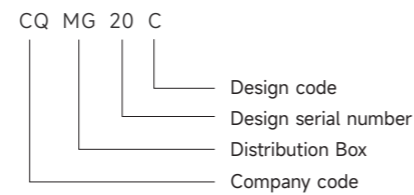

Technical Specifications

Product Name	Model	Box Base Dimensions (mm)	Sheet Metal Thickness (mm)
(Single Row) Glass Panel Power Distribution Box	15-18 positions	260X391X100	1.1
	18-22 positions	260X463X100	1.1
(Double Row) Glass Panel Power Distribution Box	32-36 positions	400X391X100	1.1
	48-52 positions	540X391X100	1.1
(Combined Power & Weak Current) Glass Panel	14-20 positions	500X427X100	1.1
	20-26 positions	500X535X100	1.1
(Information Box) Glass Panel Weak Current Box	300X400	300X400X110	1.1

CQMG03 Series

Distribution Block



Product Features

- Busbar/terminal for distribution circuits
- Current rating: 125A/160A

Type Designation

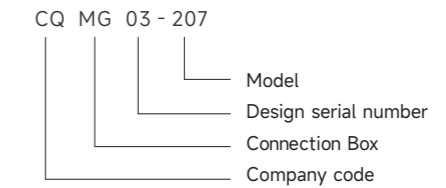

Technical Specifications

Parameter	Value
Rated insulation voltage	500V
Rated current (Ie)	125A/160A
Frequency	50Hz
Short-time withstand (Icw)	4.5kA
Peak withstand (Ipk)	20kA

Configuration Table:

Model	Conductive Rows	Terminals per Row
CQMG03-207	2	7
CQMG03-215	2	15
CQMG03-407	4	7
CQMG03-411	4	11
CQMG03-415	4	15
CQMG03-411(160A)	4	11

Dimensions(mm)

Item	b (mm)
CQMG03-207	65
CQMG03-215	132

Item	b (mm)
CQMG03-407	65
CQMG03-411	100
CQMG03-415	132

Item	b (mm)
CQMG03-411(160A)	167

Ordering Specification

Please specify the following when ordering:

1.Product Model: CQMG03-207

2.Quantity: [e.g.: 100 pcs]

Ordering Example:

CQMG03-207 100 pcs

CQIL6/7

Indicator Light



Product Features

- Key Specifications:
- Rated voltage: 230V AC
- Power consumption: 0.5W
- Colors: Red/Yellow/Green/Blue
- Conductor: 1.5-2.5 mm² copper

Type Designation

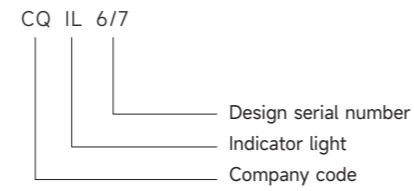

Technical Specifications

Parameter	
Rated voltage(v)	230V
Poles	1P
Power loss	0.5W
Cross-sectional area	16mm ²
Mounting type	Din rail embedded
Color	Red,Green,Yellow,Blue
Model	CQIL6 Convex,CQIL7 flat

Dimensions(mm)

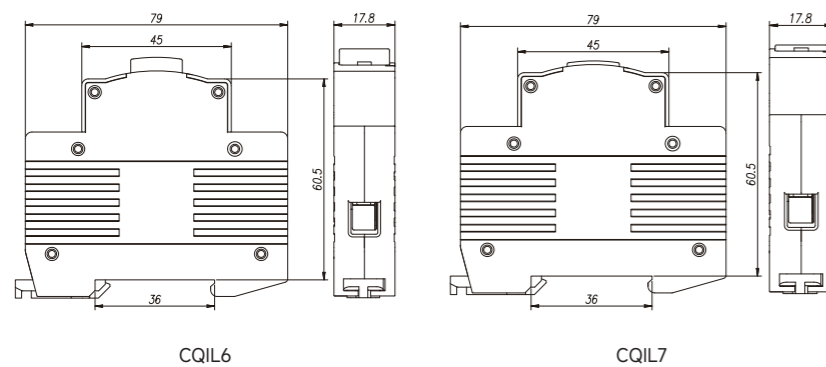

Ordering Specification

Please specify the following when ordering:

- 1.Product Model: CQIL6/7
- 2.Quantity: [e.g.: 100 pcs]

Ordering Example:
CQIL6/7 100 pcs

CQP7

Modular Socket



Product Features

- Rated voltage: 250V
- Rated current: 16A
- Type: French standard
- Conductor: 1.5-2.5 mm² copper

Type Designation

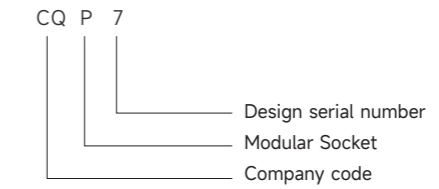

Dimensions(mm)

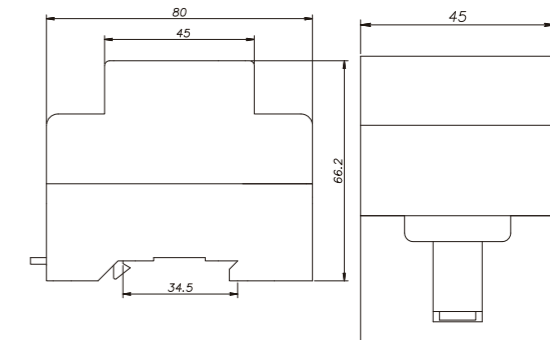

Ordering Specification

Please specify the following when ordering:

- 1.Product Model: CQP7
- 2.Quantity: [e.g.: 100 pcs]

Ordering Example:
CQP7 100 pcs

CQP20 Series
Modular Socket

CQP20



Product Features

- Rated voltage: 250V
- Rated current: 16A
- Type: Germany, French
- Conductor: 1.5-2.5 mm² copper
- Certifications: Dual DE/FR compliance
- Features: Flame-retardant / DIN rail mount

Type designation

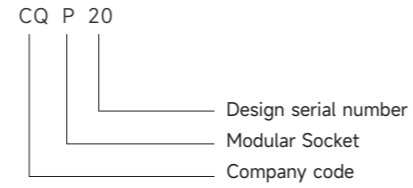

Dimensions(mm)

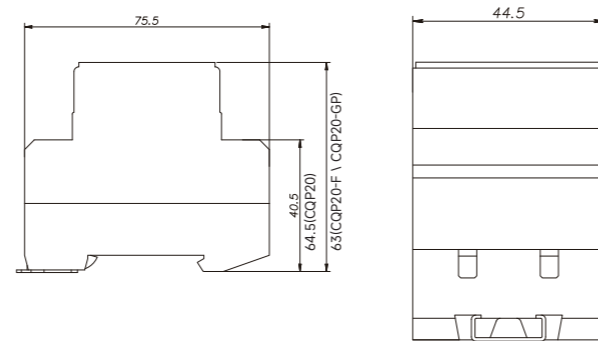

Ordering Specification

Please specify the following when ordering:
 1.Product Model: CQP20,CQP20-F,CQP20-GP
 2.Quantity: [e.g.: 100 pcs]
 Ordering Example:
 CQP20 100 pcs

CQP20-F



CQP20-GP



CQBE3
Bell



Product Features

- Alarm sound signal device
- For 50Hz AC/230V circuits
- Conductor: 1.5-2.5 mm² copper

Type Designation

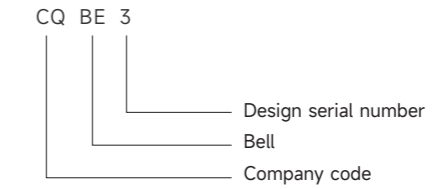

Dimensions(mm)

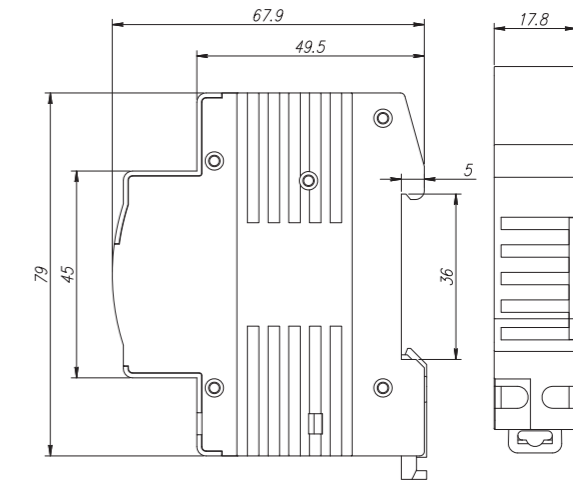

Ordering Specification

Please specify the following when ordering:
 1.Product Model: CQBE3
 2.Quantity: [e.g.: 100 pcs]
 Ordering Example:
 CQBE3 100 pcs

CQM5 Series

Molded case circuit breaker



Product Features

- Compact design with high breaking capacity (classified into types C, L, H based on performance).
- Short arc-extinguishing distance and strong anti-vibration performance.
- Modular structure for easy installation and maintenance.
- Suitable for both distribution network protection and motor circuit protection.
- Complies with GB/T 14048.2 and IEC 60947-2 standards.

Operating & Installation Conditions

- Ambient temperature: -5°C to +40°C (average ≤ +35°C within 24 hours).
- Altitude ≤ 2000 meters above sea level.
- Relative humidity ≤ 50% at +40°C.
- Must be mounted vertically with tilt tolerance within ±5°.
- Pollution degree: 3.
- Suitable for protection in distribution and motor circuits.

Technical Specifications

Model number	CQM5-63			CQM5-100	
Rated current of frame level Inm(A)	63			100	
Rated current In(A),at 40°C	10, 16, 20, 32, 40, 50, 63			10, 16, 20, 32, 40, 50, 63, 80, 100	
Rated operating voltage Ue(V)	AC380/400/415V			AC380/400/415V	
	AC660/690V			AC660/690V	
Rated insulation voltage Ui (V)	1000			1000	
Rated impulse withstand voltage Uimp(KV)	8			8	
Mechanical life	20000			20000	
Electrical life(AC415V)	8000			8000	
Trip mechanisms and protection types	Thermal-magnetic trip			Thermal-magnetic trip	
Selectivity category	A			A	
Number of poles	3P	4P		3P	4P
Breaking capacity designation	L	M	-	C	C
Rated ultimate short-circuit breaking capacity (Icu) (kA)	AC380/400/415V	36	55	55	40
	AC660/690V	/	12	12	12
Rated service short-circuit breaking capacity (Ics) (kA)	AC380/400/415V	36	40	40	30
	AC660/690V	/	10	10	10
Phase spacing (mm)	25			25	
Arc distance (mm)	≤50			≤50	
Operating ambient temp	-35 °C to +70°C			-35 °C to +70°C	
Accessory	Auxiliary contacts	●	●	●	●
	Alarm contacts	●	●	●	●
	Shunt Release	●	●	●	●
	Under-Voltage Release	●	●	●	●
	Motor Operating Mechanism	●	●	●	●
	Manual Handle Assembly	●	●	●	●
	Fixed Type Rear-Mounting Kit	●	●	●	●
	Plug-in Type, Front-of-Panel	●	●	●	●
	Plug-in Type, Rear-of-Panel	●	●	●	●
	Mechanical Interlock	●	●	●	●
Instantaneous protection	Power distribution protection	In≤32A:400A;In≥40A:10In			In≤32A:400A;In≥40A:10In
	Electric motor protection	In≤32A:400A;In≥40A:12In			In≤32A:400A;In≥40A:12In
Overall dimensions (mm) (L-W-H)		3 P	130-75-65		130-75-65
		4 P	130-100-65		130-100-65

Note: ● for optional accessories; “-” for no optional accessories.

Type designation



Code Position	Code Symbol	Meaning & Explanation
①	CQ	Enterprise Code: Zhejiang Chuangqi Electric Co., LTD.
②	M	Product Category: Molded Case Circuit Breaker
③	5	Design Serial Number
④	125	Rated Frame Current (A): Options: 63, 100, 125, 250, 400, 630, 800
⑤	M	Breaking Capacity Class: • C - Basic Type • L - Standard Type • M - Higher Breaking Type • H - High Breaking Type
⑥	□	Operation Mode: • (No Code) - Manual Direct Operation • Z - Rotary Handle Operation • P - Electric Operation
⑦	4	Number of Poles: • 3 - Three Poles • 4 - Four Poles
⑧	300	Trip Unit & Accessories Code: • 3 - Electronic Trip (Compound Trip) • 2 - Magnetic Trip Only (Single Magnetic Trip) • 00 - No Accessories (Refer to accessory table for specific codes)
⑨	□	Application Type: • (No Code) - Distribution Protection • 2 - Motor Protection
⑩	B	N-Pole Type (For 4P products only, 3P has no code): • Type A: N-pole is always connected, without overcurrent release. • Type B: N-pole breaks with other poles, without overcurrent release. • Type C: N-pole breaks with other poles, with overcurrent release. • Type D: N-pole is always connected, with overcurrent release.
⑪	125A	Rated Current: See technical parameter table for available values.
⑫	□	Terminal & Connection Type: • (No Code) - Front Terminal Connection • B - Rear Terminal Connection • C - Plug-in Type

Technical Specifications

Model number	CQM5-125				CQM5-250					
Rated current of frame level In(A)	125				250					
Rated current In(A),at 40°C	10, 16, 20, 32, 40, 50, 63, 80, 100, 125				100,125,140,160,180,200, 225,250					
Rated operating voltage Ue(V)	AC380/400/415V				AC380/400/415V					
	AC660/690V				AC660/690V					
Rated insulation voltage Ui (V)	1000				1000					
Rated impulse withstand voltage Uimp(KV)	8				8					
Mechanical life	20000				20000					
Electrical life(AC415V)	8000				8000					
Trip mechanisms and protection types	Thermal-magnetic trip				Thermal-magnetic trip					
Selectivity category	A				A					
Number of poles	3P	3P、4P	4P		3P	3P、4P	4P			
Breaking capacity designation	C	L	M	H	C	L	M	H		
Rated ultimate short-circuit breaking capacity (Icu) (kA)	AC380/400/415V	36	50	70	100	36	50	70	100	
	AC660/690V	/	/	20	/	/	/	20	/	
Rated service short-circuit breaking capacity (Ics) (kA)	AC380/400/415V	25	36	50	70	25	36	50	70	
	AC660/690V	/	/	10	/	/	/	10	/	
Phase spacing (mm)	30				35					
Arc distance (mm)	≤50				≤100					
Operating ambient temp	-35 °C to +70°C				-35 °C to +70°C					
Accessory	Auxiliary contacts	●	●	●	●	●	●	●	●	
	Alarm contacts	●	●	●	●	●	●	●	●	
	Shunt Release	●	●	●	●	●	●	●	●	
	Under-Voltage Release	●	●	●	●	●	●	●	●	
	Motor Operating Mechanism	●	●	●	●	●	●	●	●	
	Manual Handle Assembly	●	●	●	●	●	●	●	●	
	Fixed Type Rear-Mounting Kit	●	●	●	●	●	●	●	●	
	Plug-in Type, Front-of-Panel	●	●	●	●	●	●	●	●	
	Plug-in Type, Rear-of-Panel	●	●	●	●	●	●	●	●	
	Mechanical Interlock	●	●	●	●	●	●	●	●	
Instantaneous protection	Power distribution protection	In≤40A:400A;In≥50A:10In				10In				
	Electric motor protection	In≤40A:400A;In≥50A:12In				12In				
Overall dimensions (mm) (L-W-H)		3 P	155-90-75.5				165-105-75			
		4 P	155-120-87				165-140-100			

Note: ● for optional accessories; “-” for no optional accessories.

Technical Specifications

Model number	CQM5-400					CQM5-630						
Rated current of frame level In(A)	400					630						
Rated current In(A),at 40°C	225,250,315,350,400					400,500,630						
Rated operating voltage Ue(V)	AC380/400/415V					AC380/400/415V						
	AC660/690V					AC660/690V						
Rated insulation voltage Ui (V)	1000					1000						
Rated impulse withstand voltage Uimp(KV)	8					8						
Mechanical life	10000					1000						
Electrical life(AC415V)	7000					7000						
Trip mechanisms and protection types	Thermal-magnetic trip					Thermal-magnetic trip						
Selectivity category	A					A						
Number of poles	3P		4P	3P		3P		4P	3P			
Breaking capacity designation	C	L	M	/	H	L	M	/	H			
Rated ultimate short-circuit breaking capacity (Icu) (kA)	AC380/400/415V	36	50	70	70	100	50	70	70	100		
	AC660/690V	/	/	20	20	/	/	20	20	/		
Rated service short-circuit breaking capacity (Ics) (kA)	AC380/400/415V	36	50	70	70	75	50	70	70	75		
	AC660/690V	/	/	15	15	/	/	15	15	/		
Phase spacing (mm)	48					70						
Arc distance (mm)	≤100					≤100						
Operating ambient temp	-35 °C to +70°C					-35 °C to +70°C						
Accessory	Auxiliary contacts	●	●	●	●	●	●	●	●	●		
	Alarm contacts	●	●	●	●	●	●	●	●	●		
	Shunt Release	●	●	●	●	●	●	●	●	●		
	Under-Voltage Release	●	●	●	●	●	●	●	●	●		
	Motor Operating Mechanism	●	●	●	●	●	●	●	●	●		
	Manual Handle Assembly	●	●	●	●	●	●	●	●	●		
	Fixed Type Rear-Mounting Kit	●	●	●	●	●	●	●	●	●		
	Plug-in Type, Front-of-Panel	●	●	●	●	●	●	●	●	●		
	Plug-in Type, Rear-of-Panel	●	●	●	●	●	●	●	●	●		
	Mechanical Interlock	●	●	●	●	●	●	●	●	●		
Instantaneous protection	Power distribution protection	10In					10In					
	Electric motor protection	12In					12In					
Overall dimensions (mm) (L-W-H)		3 P	275-150-104.5					275-150-104.5				
		4 P	275-198-104.5					275-198-104.5				

Note: ● for optional accessories; “-” for no optional accessories.

Technical Specifications

Model number		CQM5-800			
Rated current of frame level In(A)		800			
Rated current In(A),at 40°C		400,500,630,700,800			
Rated operating voltage Ue(V)		AC380/400/415V AC660/690V			
Rated insulation voltage Ui (V)		1000			
Rated impulse withstand voltage Uimp(KV)		8			
Mechanical life		10000			
Electrical life(AC415V)		7000			
Trip mechanisms and protection types		Thermal-magnetic trip			
Selectivity category		A			
Number of poles		3P	4P	3P	3P
Breaking capacity designation		L	M	/	H
Rated ultimate short-circuit breaking capacity (Icu) (kA)	AC380/400/415V	50	70	70	100
	AC660/690V	/	20	20	/
Rated service short-circuit breaking capacity (Ics) (kA)	AC380/400/415V	50	70	70	75
	AC660/690V	/	15	15	/
Phase spacing (mm)		70			
Arc distance (mm)		≤100			
Operating ambient temp		-35 °C to +70°C			
Accessory	Auxiliary contacts	●	●	●	●
	Alarm contacts	●	●	●	●
	Shunt Release	●	●	●	●
	Under-Voltage Release	●	●	●	●
	Motor Operating Mechanism	●	●	●	●
	Manual Handle Assembly	●	●	●	●
	Fixed Type Rear-Mounting Kit	●	●	●	●
	Plug-in Type, Front-of-Panel	●	●	●	●
	Plug-in Type, Rear-of-Panel	●	●	●	●
	Mechanical Interlock	●	●	●	●
Instantaneous protection	Power distribution protection	10In			
	Electric motor protection	12In			
Overall dimensions (mm) (L-W-H)	3 P	280-210-112			
	4 P	280-280-112			

Note: ● for optional accessories; “-” for no optional accessories.

Accessory List

Model number		CQM5-63/100/125		CQM5-250		CQM5-400/630		CQM5-800	
Number of poles		3P	4P	3P	4P	3P	4P	3P	4P
Accessory code	Accessory name								
00	None								
10	Shunt Release (left mounted)								
	Shunt Release (right mounted)								
20	Two Auxiliary Contacts (left mounted)								
	Two Auxiliary Contacts (right mounted)								
21	Single Auxiliary Contact (left mounted)								
	Single Auxiliary Contact (right mounted)								
30	Undervoltage Release (left mounted)								
	Undervoltage Release (right mounted)								
40	Shunt Release + Two Auxiliary Contacts								
41	Shunt Release + Single Auxiliary Contact								
50	Shunt Release + Undervoltage Release								
60	Two Sets of Auxiliary Contacts								
61	Two Sets of Single Auxiliary Contacts								
70	Undervoltage Release + Two Auxiliary Contacts								
71	Undervoltage Release + Single Auxiliary Contact								
08	Alarm Contact (left mounted)								
	Alarm Contact (right mounted)								
18	Shunt Release + Alarm Contact								
28	Two Auxiliary Contacts + Alarm Contact								
38	Undervoltage Release + Alarm Contact								
48	Shunt Release + Auxiliary Alarm Contact								
58	Auxiliary Alarm Contact (left mounted)								
	Auxiliary Alarm Contact (right mounted)								
68	Two Auxiliary Contacts + Auxiliary Alarm Contact								
78	Undervoltage Release + Auxiliary Alarm Contact								

Note:



- Alarm Contact ○ Auxiliary Contact
- Undervoltage release □ Shunt release

Dimensions (mm)

CQM5-63/100
Front Terminal Connection Dimensions (X-X, Y-Y denote center points for 3P breakers)

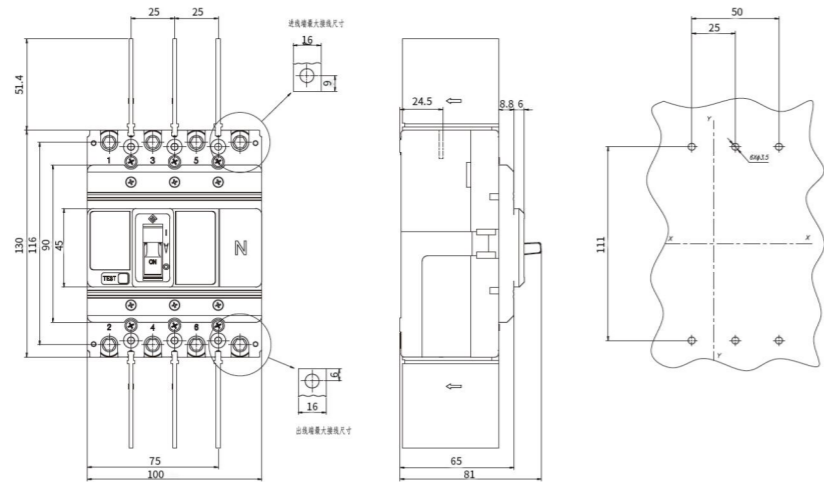

CQM5-125 (C, L, M, H Types)
Front Terminal Connection Dimensions
(X-X, Y-Y denote center points for 3P breakers)

Model number	H (mm)	H1 (mm)
CQM5-125C、125L	75.5	101.5
CQM5-125M、125H	87	113

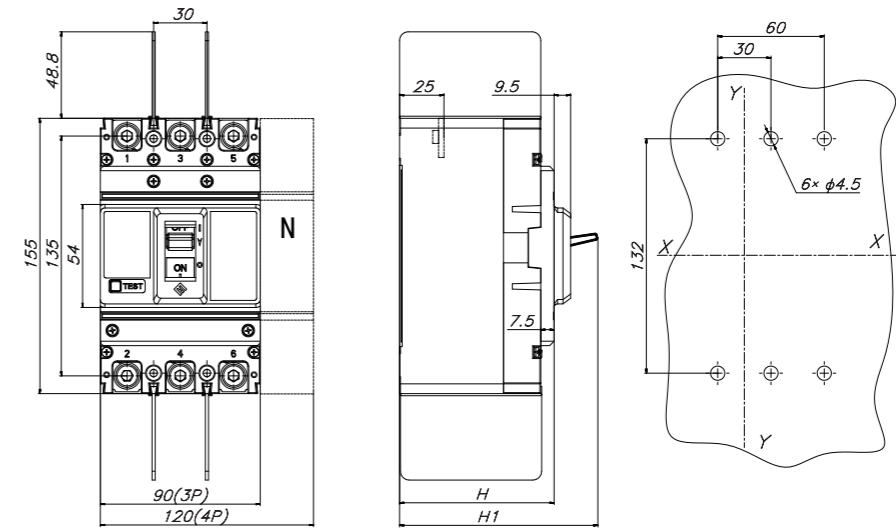

CQM5-250 (C, L, M, H Types)
Front Terminal Connection Dimensions
(X-X, Y-Y denote center points for 3P breakers)

Model number	H (mm)	H1 (mm)
CQM5-250C、250L	75	103.7
CQM5-250M、250H	100	128.7

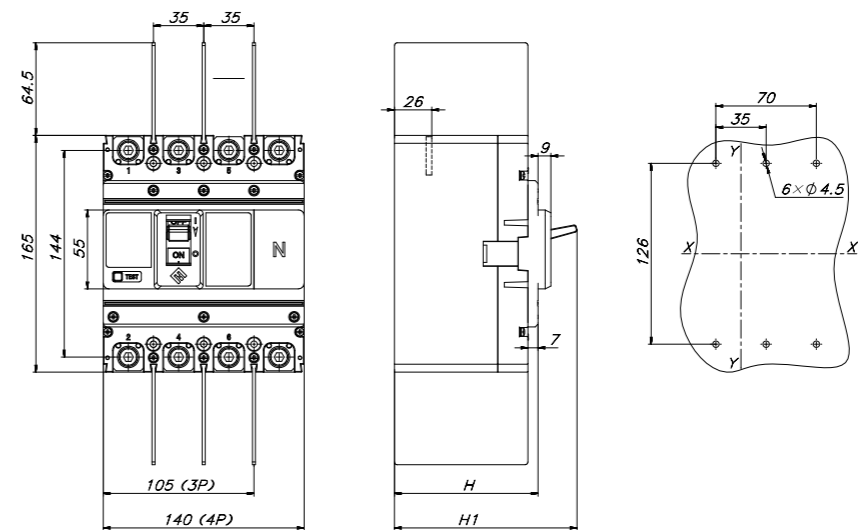

CQM5-400 (C, L, M, H Types)
CQM5-630 (C, L, M, H Types)
Front Terminal Connection Dimensions (X-X, Y-Y denote center points for 3P breakers)

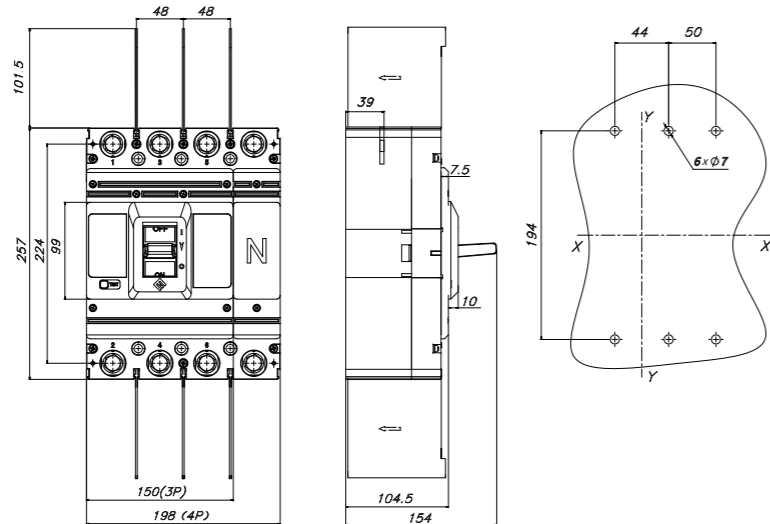

CQM5-800 (L, M, H Types)
Front Terminal Connection Dimensions (X-X, Y-Y denote center points for 3P breakers)

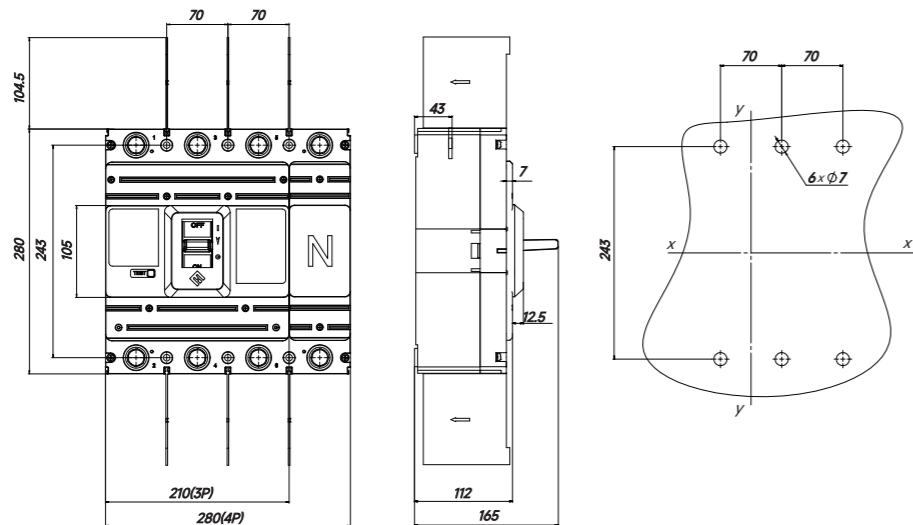

Note: Undefined tolerances comply with grade GB/T 1804-80.

CQM5L Series

Residual current protected molded case circuit breaker



Product Features

- Compact design with high breaking capacity.
- High short-circuit making capacity and vibration resistance.
- Modular structure for quick and easy installation.
- Provides overload, short-circuit, and residual current (earth fault) protection.
- Adjustable residual current protection with selectable delay levels (3 or 4 stages) and configurable leakage trip current.
- Equipped with a leakage trip indicator.
- Suitable for circuits with AC voltage up to 415V and frequency 50Hz/60Hz.
- Complies with GB/T 14048.2 and IEC 60947-2 standards.

Operating & Installation Conditions

- Ambient temperature: -5°C to +40°C (average ≤ +35°C within 24 hours).
- Altitude ≤ 2000 meters above sea level.
- Relative humidity ≤ 50% at +40°C.
- Must be mounted vertically with tilt tolerance within ±5°.
- Pollution degree: 3.
- Suitable for protection in distribution and motor circuits.

Type designation



Code Position	Code Symbol	Meaning & Explanation
①	CQ	Enterprise Code: Zhejiang Chuangqi Electric Co., LTD.
②	M	Product Category: Molded Case Circuit Breaker
③	5	Design Serial Number
④	L	Special Protection Function Residual Current Protection (Options: L=RC Protection)
⑤	125	Rated Frame Current (A): Options: 125, 250, 400, 630
⑥	□	Operation Mode: • (No Code) - Manual Direct Operation • Z - Rotary Handle Operation • P - Electric Operation
⑦	4	Number of Poles: • 3 - Three Poles • 4 - Four Poles
⑧	300	Trip Unit & Accessories Code: • 3 - Electronic Trip (Compound Trip) • 2 - Magnetic Trip Only (Single Magnetic Trip) • 00 - No Accessories (Refer to accessory table for specific codes)
⑨	□	Application Type: • (No Code) - Distribution Protection • 2 - Motor Protection N-Pole Type (For 4P products only, 3P has no code): • Type A: N-pole is always connected, without overcurrent release. • Type B: N-pole breaks with other poles, without overcurrent release. • Type C: N-pole breaks with other poles, with overcurrent release. • Type D: N-pole is always connected, with overcurrent release.
⑩	B	
⑪	125A	Rated Current: See technical parameter table for available values.
⑫	Y	Time-Delay Function • Y: With Delay • F: Without Delay
⑬	□	Terminal & Connection Type: • (No Code) - Front Terminal Connection • B - Rear Terminal Connection • C - Plug-in Type

Technical Specifications

Model number	CQM5L-125	CQM5L-250	
Rated current of frame level In(A)	125	250	
Rated current In(A),at 40°C	10, 16, 20, 32, 40, 50, 63, 80, 100, 125	100,125,140,160,180,200, 225,250	
Rated operating voltage Ue(V)	AC380/400/415V	AC380/400/415V	
Rated insulation voltage Ui (V)	1000	1000	
Rated impulse withstand voltage Uimp(KV)	8	8	
Mechanical life	20000	20000	
Electrical life(AC415V)	8000	8000	
Trip mechanisms and protection types	Thermal-magnetic trip	Thermal-magnetic trip	
Selectivity category	A	A	
Number of poles	3P、 4P	3P、 4P	
Rated Ultimate Short-Circuit Breaking Capacity (Icu) (kA)	70	70	
Rated Service Short-Circuit Breaking Capacity (Ics) (kA)	50	50	
Rated Residual Operating Current (IΔn)	Time-delayed + Non-delayed	100/300/500	
	Non-delayed only	30/100/300/500	
Rated Residual Current Type	AC type	AC type	
Rated Residual Making & Breaking Capacity (IΔm)	1/4Icu	1/4Icu	
Phase spacing (mm)	30	35	
Arc distance (mm)	≤50	≤50	
Operating ambient temp	-35 °C to +70°C	-35 °C to +70°C	
Accessory	Auxiliary contacts	●	
	Alarm contacts	●	
	Shunt Release	●	
	Under-Voltage Release	●	
	Motor Operating Mechanism	●	
	Manual Handle Assembly	●	
	Fixed Type Rear-Mounting Kit	●	
	Plug-in Type, Front-of-Panel	●	
	Plug-in Type, Rear-of-Panel	●	
	Mechanical Interlock	●	
Instantaneous protection	Power distribution protection	In≤40A:400A;In≥50A:10In	
	Electric motor protection	In≤40A:400A;In≥50A:12In	
Overall dimensions (mm) (L-W-H)		3 P	155-90-90
		4 P	155-120-90
			165-105-103
			165-140-103

Note: ● for optional accessories; “-” for no optional accessories.

Technical Specifications

Model number	CQM5L-400	CQM5L-630	
Rated current of frame level In(A)	400	630	
Rated current In(A),at 40°C	225,250,315,350,400	400,500,630	
Rated operating voltage Ue(V)	AC380/400/415V	AC380/400/415V	
Rated insulation voltage Ui (V)	1000	1000	
Rated impulse withstand voltage Uimp(KV)	8	8	
Mechanical life	10000	10000	
Electrical life(AC415V)	7000	7000	
Trip mechanisms and protection types	Thermal-magnetic trip	Thermal-magnetic trip	
Selectivity category	A	A	
Number of poles	3P、 4P	3P、 4P	
Rated Ultimate Short-Circuit Breaking Capacity (Icu) (kA)	70	70	
Rated Service Short-Circuit Breaking Capacity (Ics) (kA)	70	70	
Rated Residual Operating Current (IΔn)	Time-delayed + Non-delayed	100/300/500/1000	
	Non-delayed only	/	
Rated Residual Current Type	AC type	AC type	
Rated Residual Making & Breaking Capacity (IΔm)	1/4Icu	1/4Icu	
Phase spacing (mm)	48	70	
Arc distance (mm)	≤100	≤100	
Operating ambient temp	-35 °C to +70°C	-35 °C to +70°C	
Accessory	Auxiliary contacts	●	
	Alarm contacts	●	
	Shunt Release	●	
	Under-Voltage Release	●	
	Motor Operating Mechanism	●	
	Manual Handle Assembly	●	
	Fixed Type Rear-Mounting Kit	●	
	Plug-in Type, Front-of-Panel	●	
	Plug-in Type, Rear-of-Panel	●	
	Mechanical Interlock	●	
Instantaneous protection	Power distribution protection	10In	
	Electric motor protection	12In	
Overall dimensions (mm) (L-W-H)		3 P	257-150-104.5
		4 P	257-198-104.5
			280-210-112
			280-280-112

Note: ● for optional accessories; “-” for no optional accessories.

Accessory List

Model number	CQM5L-125		CQM5L-250		CQM5L-400		CQM5L-630	
Number of poles	3P	4P	3P	4P	3P	4P	3P	4P
Accessory code	Accessory name							
00	None							
10	Shunt Release (left mounted)							
20	Two Auxiliary Contacts (left mounted)							
	Two Auxiliary Contacts (right mounted)							
21	Single Auxiliary Contact (left mounted)							
	Single Auxiliary Contact (right mounted)							
30	Undervoltage Release (left mounted)							
40	Shunt Release + Two Auxiliary Contacts							
41	Shunt Release + Single Auxiliary Contact							
60	Two Sets of Auxiliary Contacts							
61	Two Sets of Single Auxiliary Contacts							
70	Undervoltage Release + Two Auxiliary Contacts							
71	Undervoltage Release + Single Auxiliary Contact							
08	Alarm Contact (left mounted)							
	Alarm Contact (right mounted)							
18	Shunt Release + Alarm Contact							
28	Two Auxiliary Contacts + Alarm Contact							
38	Undervoltage Release + Alarm Contact							
48	Shunt Release + Auxiliary Alarm Contact							
58	Auxiliary Alarm Contact (left mounted)							
	Auxiliary Alarm Contact (right mounted)							
68	Two Auxiliary Contacts + Auxiliary Alarm Contact							
78	Undervoltage Release + Auxiliary Alarm Contact							

Note:



Dimensions (mm)

CQM5L-125
Front Terminal Connection Dimensions (X-X, Y-Y denote center points for 3P breakers)

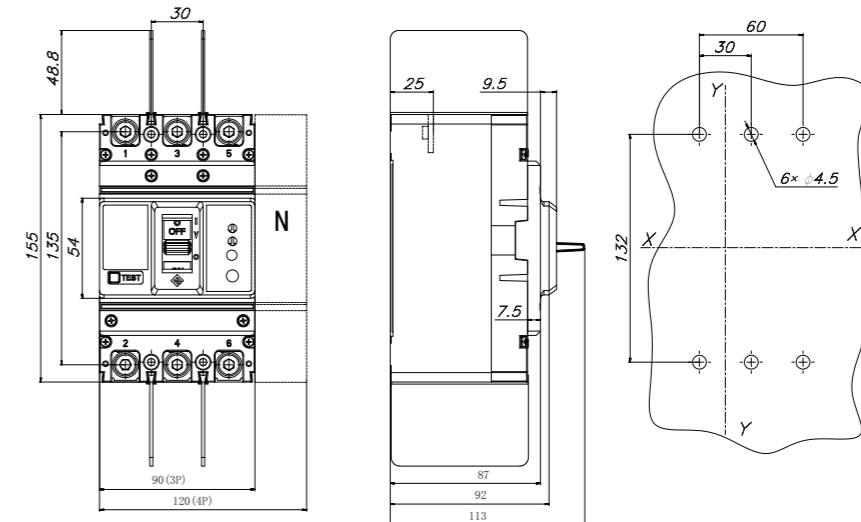

CQM5L-250
Front Terminal Connection Dimensions (X-X, Y-Y denote center points for 3P breakers)

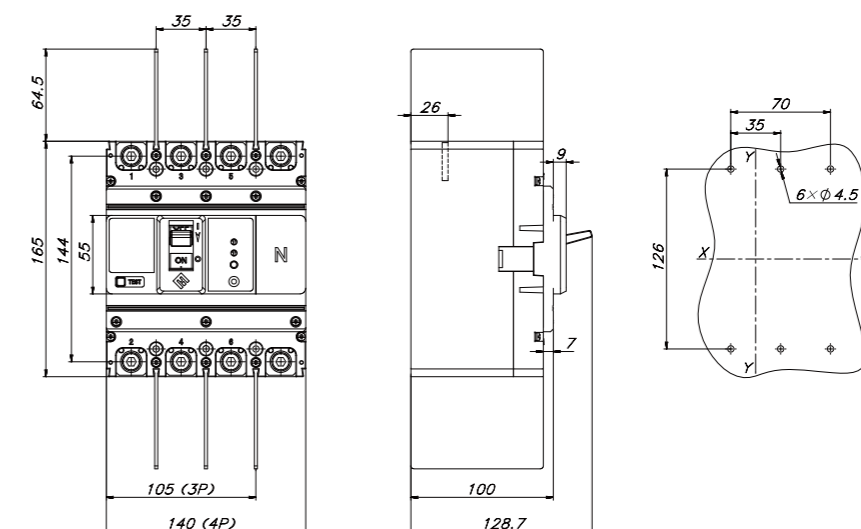

CQM5L-400
Front Terminal Connection Dimensions (X-X, Y-Y denote center points for 3P breakers)

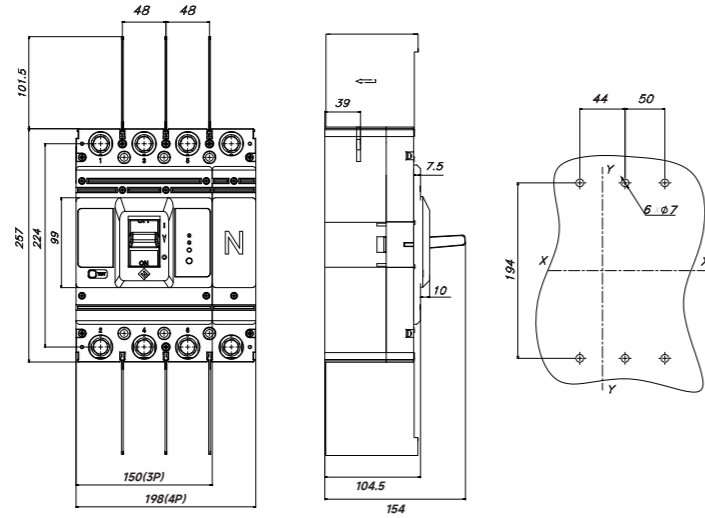

CQM5L-630
Front Terminal Connection Dimensions

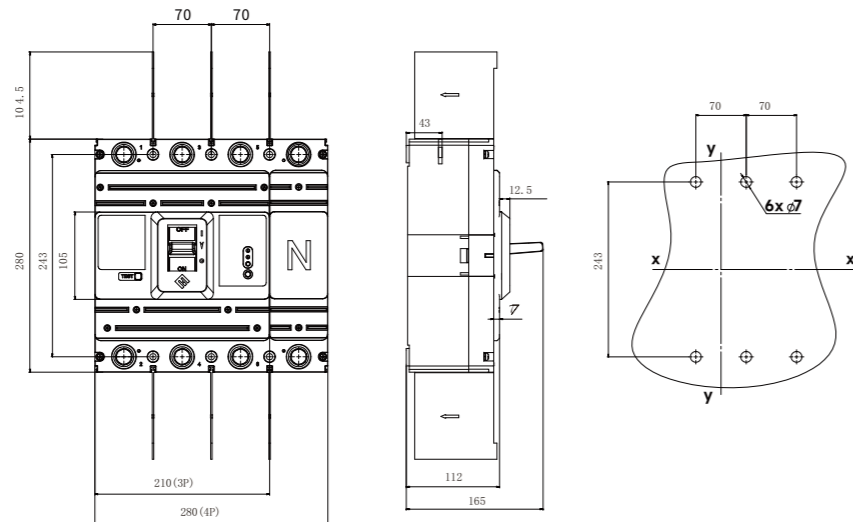

Note: Undefined tolerances comply with grade GB/T 1804-80.

CQM5E Series Molded case circuit breaker



Product Features

- Compact and modular design for quick installation and maintenance.
- High breaking capacity (M-type: higher breaking, H-type: high breaking).
- Provides overload, short-circuit, and ground fault protection, with optional undervoltage protection.
- Supports communication module integration for remote monitoring and control (remote trip, adjustment, testing, and signaling).
- Suitable for both distribution network and motor protection applications.
- Complies with IEC 60947-1, IEC 60947-2, and GB/T 14048 standards.

Operating & Environmental Conditions

- Designed for vertical mounting ($\pm 5^\circ$ tilt allowed unless specified).
- Suitable for infrequent circuit switching and motor starting operations.
- Pollution degree: 3
- Communication module can be added for smart functionality.

Type designation



Code Position	Code Symbol	Meaning & Explanation
①	CQ	Enterprise Code: Zhejiang Chuangqi Electric Co., LTD.
②	M	Molded Case Circuit Breaker
③	5	Design Serial Number
④	E	Special Protection Function Residual Current Protection (Options: L=RC Protection)
⑤	125	Rated Frame Current (A): Options: 125, 250, 400, 630, 800
⑥	M	Short-Circuit Breaking Capacity: • M: Higher Fault Capacity • H: High Fault Capacity
⑦	□	Operation Mechanism [blank]: Manual Z: Rotary Handle P: Motorized
⑧	□	Intelligence Function • [blank]: Basic Protection • G: Ground Fault Protection • T: Communication Capable • GT: Ground+Communication
⑨	4	Number of Poles: • 3 - Three Poles • 4 - Four Poles
⑩	300	Trip Unit & Accessories Code: • 3 - Electronic Trip (Compound Trip) • 00 - No Accessories (Refer to accessory table for specific codes)
⑪	□	□: Application Profile [blank]: Distribution 2: Motor Protection
⑫	B	N-Pole Type (For 4P products only): • Type A: N-pole is always connected, without overcurrent release. • Type B: N-pole breaks with other poles, without overcurrent release. • Type C: N-pole breaks with other poles, with overcurrent release. • Type D: N-pole is always connected, with overcurrent release.
⑬	□	Special Function I: Overload Alarm (non-trip)
⑭	□	Rated Current (A) Options: 32 63 125 250 400 630 800
⑮	□	Terminal & Connection Type: • (No Code) - Front Terminal Connection • B - Rear Terminal Connection • C - Plug-in Type

Technical Specifications

Model number	CQM5E-125			CQM5E-250				
Rated current In(A), 40°C	32	63	125	250				
Setting Current Ir (A), 40°C	16/20/25/32	32/40/50/63	63/80/100/125	100,125,140,160,180,200,225,250				
Rated operating voltage Ue(V)	AC380/400/415V			AC380/400/415V				
	AC660/690V			AC660/690V				
Rated insulation voltage Ui (V)	1000			1000				
Rated impulse withstand voltage Uimp(KV)	8			8				
Mechanical life	20000			20000				
Electrical life(AC415V)	8000			8000				
Trip mechanisms and protection types	Electronic			Electronic				
Selectivity category	A			A				
Number of poles	3P		4P	3P		4P		
Breaking capacity designation	M	H	/	M	H	/		
Rated ultimate short-circuit breaking capacity (Icu) (kA)	AC380/400/415V	70	85	70	85	70		
	AC660/690V	20	/	20	20	/	20	
Rated service short-circuit breaking capacity (Ics) (kA)	AC380/400/415V	50	65	50	65	50		
	AC660/690V	10	/	10	10	/	10	
Phase spacing (mm)	30			35				
Arc distance (mm)	≤50			≤100				
Operating ambient temp	-35 °C to +70°C			-35 °C to +70°C				
Rated short-time withstand current (Icw)	1kA/1s			2.5kA/1s				
Accessory	Auxiliary contacts	●	●	●	●	●		
	Alarm contacts	●	●	●	●	●		
	Shunt Release	●	●	●	●	●		
	Under-Voltage Release	●	●	●	●	●		
	Motor Operating Mechanism	●	●	●	●	●		
	Manual Handle Assembly	●	●	●	●	●		
	Fixed Type Rear-Mounting Kit	●	●	●	●	●		
	Plug-in Type, Front-of-Panel	●	●	●	●	●		
	Plug-in Type, Rear-of-Panel	●	●	●	●	●		
	Mechanical Interlock	●	●	●	●	●		
Short-circuit protection types	Short-time delay protection (S)	I _{sd} = (2-12) I _r			I _{sd} = (2-12) I _r			
	Instantaneous protection (I)	I _i = (4-14) I _r			I _i = (4-14) I _r			
Overall dimensions (mm) (L-W-H)		3 P	155-90-90			165-105-103		
		4 P	155-120-90			165-140-103		

Note: ● for optional accessories; “-” for no optional accessories.

Technical Specifications

Model number	CQM5E-400			CQM5E-630				
Rated current In(A), 40°C	400			630				
Setting Current Ir (A), 40°C	200,225,250,280,315,350,400			400,420,440,460,480,500,530,560,600,630				
Rated operating voltage Ue(V)	AC380/400/415V			AC380/400/415V				
	AC660/690V			AC660/690V				
Rated insulation voltage Ui (V)	1000			1000				
Rated impulse withstand voltage Uimp(KV)	8			8				
Mechanical life	10000			10000				
Electrical life(AC415V)	7000			7000				
Trip mechanisms and protection types	Electronic			Electronic				
Selectivity category	B			B				
Number of poles	3P		4P	3P		4P		
Breaking capacity designation	M	H	/	M	H	/		
Rated ultimate short-circuit breaking capacity (Icu) (kA)	AC380/400/415V	70	100	70	100	70		
	AC660/690V	20	/	20	20	/	20	
Rated service short-circuit breaking capacity (Ics) (kA)	AC380/400/415V	50	75	50	75	50		
	AC660/690V	10	/	10	10	/	10	
Phase spacing (mm)	48			70				
Arc distance (mm)	≤100			≤100				
Operating ambient temp	-35 °C to +70°C			-35 °C to +70°C				
Rated short-time withstand current (Icw)	5kA/1s			10kA/1s				
Accessory	Auxiliary contacts	●	●	●	●	●		
	Alarm contacts	●	●	●	●	●		
	Shunt Release	●	●	●	●	●		
	Under-Voltage Release	●	●	●	●	●		
	Motor Operating Mechanism	●	●	●	●	●		
	Manual Handle Assembly	●	●	●	●	●		
	Fixed Type Rear-Mounting Kit	●	●	●	●	●		
	Plug-in Type, Front-of-Panel	●	●	●	●	●		
	Plug-in Type, Rear-of-Panel	●	●	●	●	●		
	Mechanical Interlock	●	●	●	●	●		
Short-circuit protection types	Short-time delay protection (S)	I _{sd} = (2-12) I _r			I _{sd} = (2-12) I _r			
	Instantaneous protection (I)	I _i = (4-14) I _r			I _i = (4-14) I _r			
Overall dimensions (mm) (L-W-H)		3 P	257-150-140.5			280-210-112		
		4 P	257-198-140.5			280-280-112		

Note: ● for optional accessories; “-” for no optional accessories.

Technical Specifications

Model number		CQM5E-800		
Rated current In(A), 40°C		800		
Setting Current Ir (A), 40°C		630, 640, 660, 680, 700, 720, 740, 760, 780, 800		
Rated operating voltage Ue(V)		AC380/400/415V AC660/690V		
Rated insulation voltage Ui (V)		1000		
Rated impulse withstand voltage Uimp(KV)		8		
Mechanical life		10000		
Electrical life(AC415V)		7000		
Trip mechanisms and protection types		Electronic		
Selectivity category		B		
Number of poles		3P	4P	
Breaking capacity designation		M	H	I
Rated ultimate short-circuit breaking capacity (Icu) (kA)	AC380/400/415V	70	100	70
	AC660/690V	20	/	20
Rated service short-circuit breaking capacity (Ics) (kA)	AC380/400/415V	50	75	50
	AC660/690V	10	/	10
Phase spacing (mm)		70		
Arc distance (mm)		≤100		
Operating ambient temp		-35 °C to +70°C		
Rated short-time withstand current (Icw)		10kA/1s		
Accessory	Auxiliary contacts	●	●	●
	Alarm contacts	●	●	●
	Shunt Release	●	●	●
	Under-Voltage Release	●	●	●
	Motor Operating Mechanism	●	●	●
	Manual Handle Assembly	●	●	●
	Fixed Type Rear-Mounting Kit	●	●	●
	Plug-in Type, Front-of-Panel	●	●	●
	Plug-in Type, Rear-of-Panel	●	●	●
Short-circuit protection types	Short-time delay protection (S)	I _{sd} = (2-12) I _r		
	Instantaneous protection (I)	I _i = (4-14) I _r		
Overall dimensions (mm) (L-W-H)		3 P	280-210-112	
		4 P	280-280-112	

Note: ● for optional accessories; “-” for no optional accessories.

Accessory List

Model number		CQM5E-125		CQM5E-250		CQM5E-400		CQM5E-630/800	
Number of poles		3P	4P	3P	4P	3P	4P	3P	4P
Accessory code	Accessory name								
00	None								
10	Shunt Release (left mounted)								
	Shunt Release (right mounted)								
20	Two Auxiliary Contacts (left mounted)								
	Two Auxiliary Contacts (right mounted)								
21	Single Auxiliary Contact (left mounted)								
	Single Auxiliary Contact (right mounted)								
30	Undervoltage Release (left mounted)								
	Undervoltage Release (right mounted)								
40	Shunt Release + Two Auxiliary Contacts								
41	Shunt Release + Single Auxiliary Contact								
50	Shunt Release + Undervoltage Release								
60	Two Sets of Auxiliary Contacts								
61	Two Sets of Single Auxiliary Contacts								
70	Undervoltage Release + Two Auxiliary Contacts								
71	Undervoltage Release + Single Auxiliary Contact								
08	Alarm Contact (left mounted)								
	Alarm Contact (right mounted)								
18	Shunt Release + Alarm Contact								
28	Two Auxiliary Contacts + Alarm Contact								
38	Undervoltage Release + Alarm Contact								
48	Shunt Release + Auxiliary Alarm Contact								
58	Auxiliary Alarm Contact (left mounted)								
	Auxiliary Alarm Contact (right mounted)								
68	Two Auxiliary Contacts + Auxiliary Alarm Contact								
78	Undervoltage Release + Auxiliary Alarm Contact								

Note:



- Alarm Contact ○ Auxiliary Contact
- Undervoltage release □ Shunt release

Dimensions (mm)

CQM5E-125 (M, H Types)
Front Terminal Connection Dimensions
(X-X, Y-Y denote center points for 3P breakers)

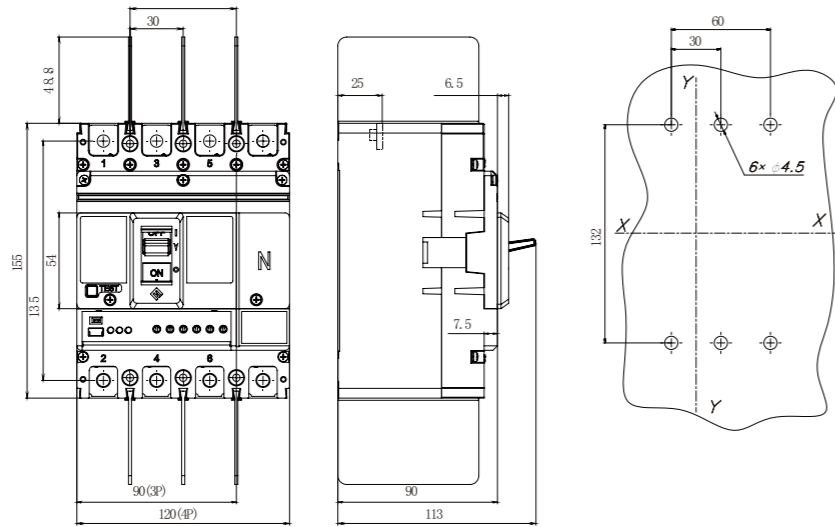

CQM5E-250 (M, H Types)
Front Terminal Connection Dimensions
(X-X, Y-Y denote center points for 3P breakers)

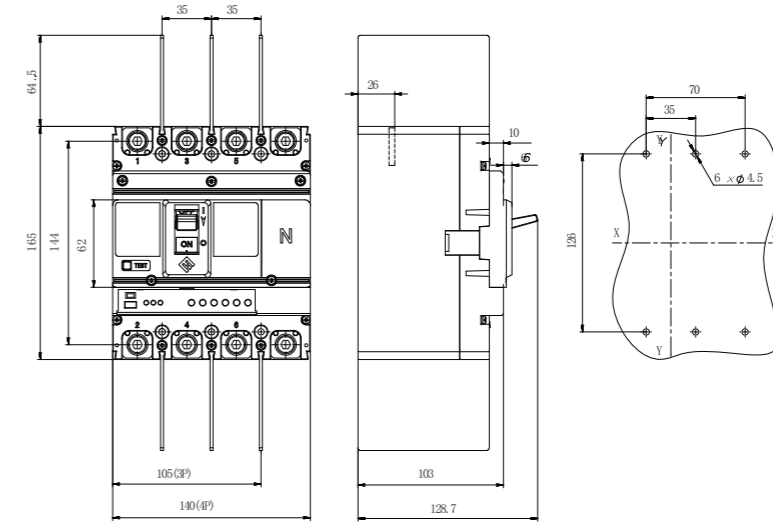

CQM5E-400 (M, H Types)
Front Terminal Connection Dimensions
(X-X, Y-Y denote center points for 3P breakers)

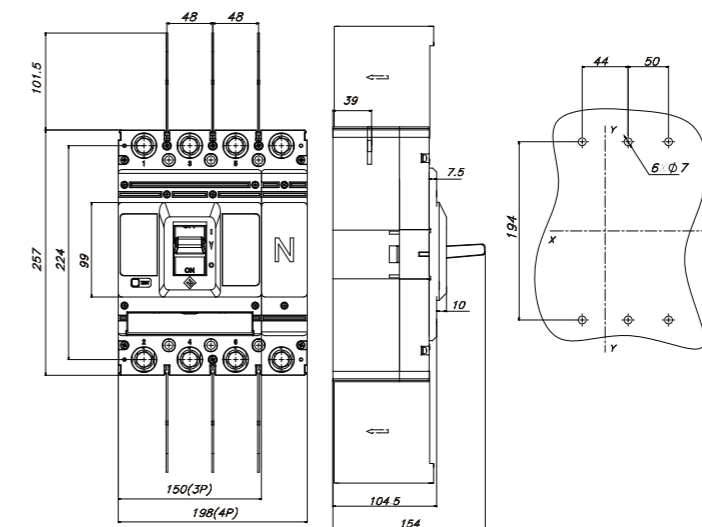

CQM5E-630 (M, H Types)、CQM5E-800 (M, H Types)
 Front Terminal Connection Dimensions
 (X-X, Y-Y denote center points for 3P breakers)

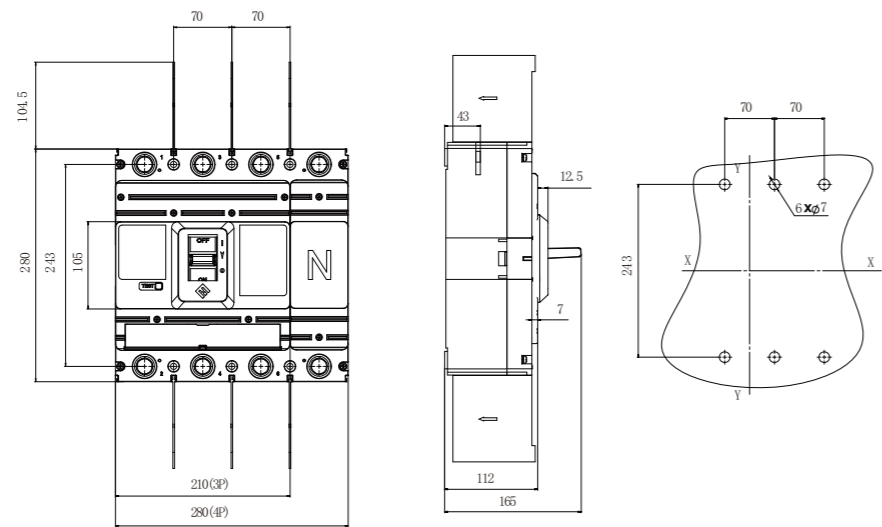

Internal Accessories

1.1 AX Auxiliary Contact

Function

Remote status indicator for breaker ON/OFF or trip-free operation, integrated into the auxiliary circuit.

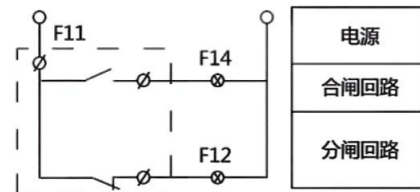

Indicating Circuit Breaker ON/OFF Status

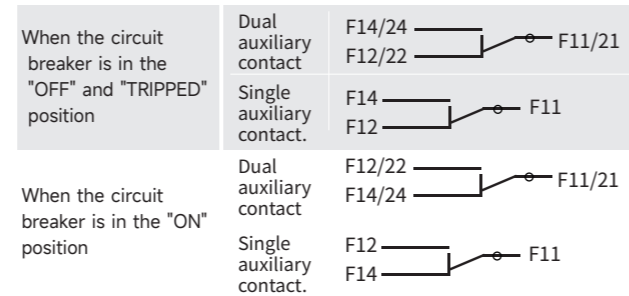

Electrical Characteristics

Classification	Frame Rating	Conventional Thermal Current (A)	Rated Operational Current (A)	
Auxiliary Contact	63, 100, 125, 250	3	AC400V	DC220V
	400, 630, 800	3	0.4	0.15

1.2 AL Alarm Contact

Wiring Diagram

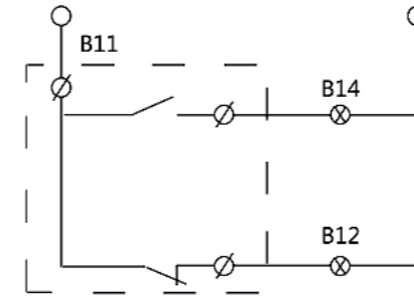

Function

Primarily used to provide a signal when a fault such as overload, short circuit, or undervoltage occurs on the circuit breaker's load side, or when it enters a free-trip state.

Reasons for the alarm contact to issue a fault indication signal:

- Overload or Short Circuit Trip
- Undervoltage Trip
- Residual Current Operation Trip
- Manual Free-Trip

Indicating Circuit Breaker ON/OFF Status

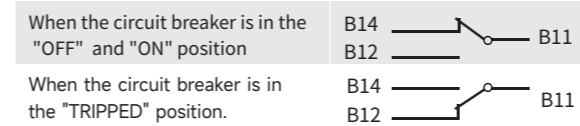

Electrical Characteristics

Classification	Frame Rating	Conventional Thermal Current (A)	Rated Operational Current (A)	
Alarm Contact	63, 100, 125, 250	3	AC400V	DC220V
	400, 630, 800	3	0.4	0.15

1.3 SHT Shunt Release

Wiring Diagram

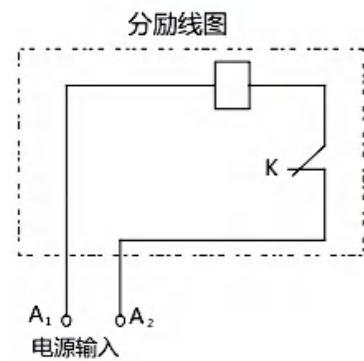

Function

The shunt release is activated by an electrical signal, enabling remote and automatic control of the circuit breaker. The shunt release shall reliably cause the circuit breaker to operate when the supply voltage is any value between 70% and 110% of the rated control supply voltage.

1.4 UVR Under-Voltage Release

Wiring Diagram

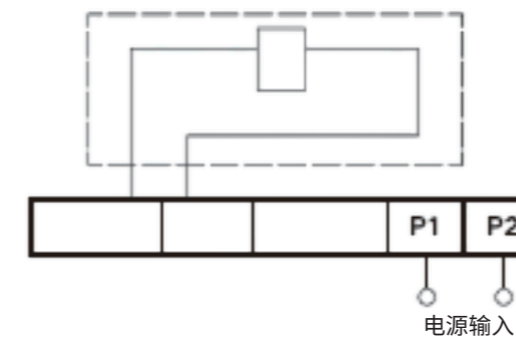

Function

Protects equipment by tripping breakers during voltage dips.

Operational Thresholds

Reliable closing: $\geq 85\%$ rated voltage
 Mandatory tripping: 70%–35% rated voltage
 Closing prevention: $< 35\%$ rated voltage

Code	Model number	Instantaneous Tripping Current (A)				Power Consumption (W)			
		DC24V	DC220V	AC230V	AC380V	DC24V	DC220V	AC230V	AC380V
1	CQM5-63/100	5.7	0.62	0.64	0.38	136.8	136.4	147.2	152
2	CQM5-125	4	0.24	0.25	0.43	97.6	52.6	57.5	173.9
3	CQM5-250	4	0.24	0.25	0.43	97.6	52.6	57.5	173.9
4	CQM5-400/630	6.8	0.48	0.76	0.28	164.5	105	176.3	112
5	CQM5-800	6.8	0.48	0.76	0.28	164.5	105	176.3	112

Code	Model number	Instantaneous Tripping Current (A)				Power Consumption (W)			
		DC24V	DC220V	AC230V	AC380V	DC24V	DC220V	AC230V	AC380V
1	CQM5L-125	4	0.24	0.25	0.43	97.6	52.6	57.5	173.9
2	CQM5L-250	4	0.24	0.25	0.43	97.6	52.6	57.5	173.9
3	CQM5L-400	6.8	0.48	0.76	0.28	164.5	105	176.3	112
4	CQM5L-630	6.8	0.48	0.76	0.28	164.5	105	176.3	112

Code	Model number	Instantaneous Tripping Current (A)				Power Consumption (W)			
		DC24V	DC220V	AC230V	AC380V	DC24V	DC220V	AC230V	AC380V
1	CQM5E-125	4	0.24	0.25	0.43	97.6	52.6	57.5	173.9
2	CQM5E-250	4	0.24	0.25	0.43	97.6	52.6	57.5	173.9
3	CQM5E-400	6.8	0.48	0.76	0.28	164.5	105	176.3	112
4	CQM5E-630	6.8	0.48	0.76	0.28	164.5	105	176.3	112
5	CQM5E-800	6.8	0.48	0.76	0.28	164.5	105	176.3	112

Code	Model number	Instantaneous Tripping Current (A)		Power Consumption (W)			
		DC24V	DC220V	Pick-up Power (W)		Hold-in Power (W)	
				AC230V	AC380V	AC230V	AC380V
1	CQM5E-125	0.2	0.3	/	/	0.5	0.5
2	CQM5E-250	0.006	0.01	/	/	0.3	0.3
3	CQM5E-400	0.006	0.01	/	/	0.8	0.9
4	CQM5E-630	0.8	0.5	190	223	0.8	0.9
5	CQM5E-800	0.8	0.5	190	223	0.8	0.9

Code	Model number	Instantaneous Tripping Current (A)		Power Consumption (W)			
		DC24V	DC220V	Pick-up Power (W)		Hold-in Power (W)	
				AC230V	AC380V	AC230V	AC380V
1	CQM5L-125	0.006	0.01	/	/	0.3	0.3
2	CQM5L-250	0.006	0.01	/	/	0.3	0.3
3	CQM5L-400	0.8	0.5	190	223	0.8	0.9
4	CQM5L-630	0.8	0.5	190	223	0.8	0.9

Code	Model number	Instantaneous Tripping Current (A)		Power Consumption (W)			
		DC24V	DC220V	Pick-up Power (W)		Hold-in Power (W)	
				AC230V	AC380V	AC230V	AC380V
1	CQM5E-125	0.006	0.01	/	/	0.3	0.3
2	CQM5E-250	0.006	0.01	/	/	0.3	0.3
3	CQM5E-400	0.8	0.5	190	223	0.8	0.9
4	CQM5E-630	0.8	0.5	190	223	0.8	0.9
5	CQM5E-800	0.8	0.5	190	223	0.8	0.9

External Accessories

2.1 Motor Operating Mechanism

Schematic Diagram

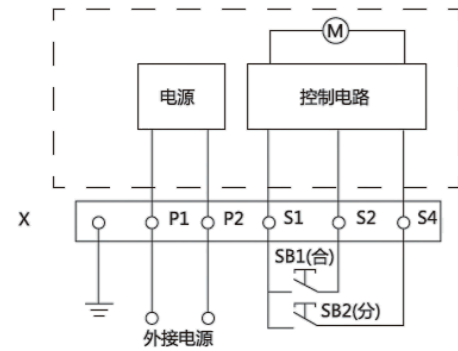

Function

Suitable for remotely closing, tripping (resetting) the circuit breaker, and for automated applications.
 Position indication for O (OFF), I (ON), and TRIPPED.
 Enables free trip operation of the circuit breaker.
 Allows manual or automatic closing and opening of the circuit breaker.
 Automatic closing or tripping can be achieved using momentary pulse signals or maintained signal control.
 Reliable closing and tripping of the circuit breaker is ensured only when the control voltage is $\geq 85\%$ and $\leq 110\%$ of the rated control voltage (U_n).

Dimensions (mm)

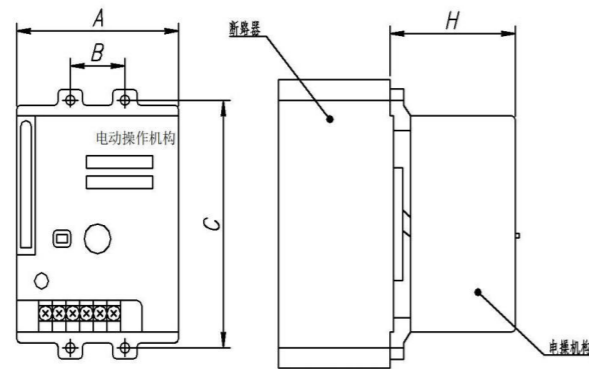

Schematic & Symbol Legend:
 SB1, SB2: Operation buttons
 (To be provided by customer)
 X: Terminal block
 P1, P2: External power supply

Code	Model number	Instantaneous Tripping Current (A)				Power Consumption (W)	Operating Mechanism Height
		DC24V	AC/DC110V	AC/DC220V	AC380V		
1	CQM5-63/100	80	≤ 180	≤ 180	≤ 350	20000	94
2	CQM5-125	80	≤ 180	≤ 180	≤ 350	20000	97
3	CQM5-250	80	≤ 180	≤ 180	≤ 350	20000	101
4	CQM5-400/630	160	≤ 250	≤ 350	≤ 600	10000	149
5	CQM5-800	160	≤ 250	≤ 350	≤ 600	10000	152

Code	Model number	Instantaneous Tripping Current (A)				Power Consumption (W)	Operating Mechanism Height
		DC24V	AC/DC110V	AC/DC220V	AC380V		
1	CQM5L-125	80	≤ 180	≤ 180	≤ 350	20000	97
2	CQM5L-250	80	≤ 180	≤ 180	≤ 350	20000	101
3	CQM5L-400/630	160	≤ 250	≤ 350	≤ 600	10000	149
4	CQM5L-800	160	≤ 250	≤ 350	≤ 600	10000	152

Code	Model number	Instantaneous Tripping Current (A)				Power Consumption (W)	Operating Mechanism Height
		DC24V	AC/DC110V	AC/DC220V	AC380V		
1	CQM5E-125	80	≤ 180	≤ 180	≤ 350	20000	97
2	CQM5E-250	80	≤ 180	≤ 180	≤ 350	20000	101
3	CQM5E-400	160	≤ 250	≤ 350	≤ 600	10000	149
4	CQM5E-630	160	≤ 250	≤ 350	≤ 600	10000	152
5	CQM5E-800	160	≤ 250	≤ 350	≤ 600	10000	152

Note: General tolerance grade shall be in accordance with GB/T 1804-c.

2.2 Manual Handle Assembly

Function

Employs a unique design and transmission mechanism to perform circuit breaker Closing, Tripping (Reset), and Opening operations via handle rotation.
 Features isolated position indication.
 Clear position indications: O (OFF), I (ON), and TRIPPED.
 The breaker in the OFF position accepts 1-3 padlocks ($\varnothing 5-8\text{mm}$), preventing inadvertent closure and locking compartment access.
 In the ON (closed) position, handle rotation mechanically prevents compartment door opening. (For emergency door access, use the handle's manual override release).
 Standard shaft length: 150mm.

Dimensions (mm)

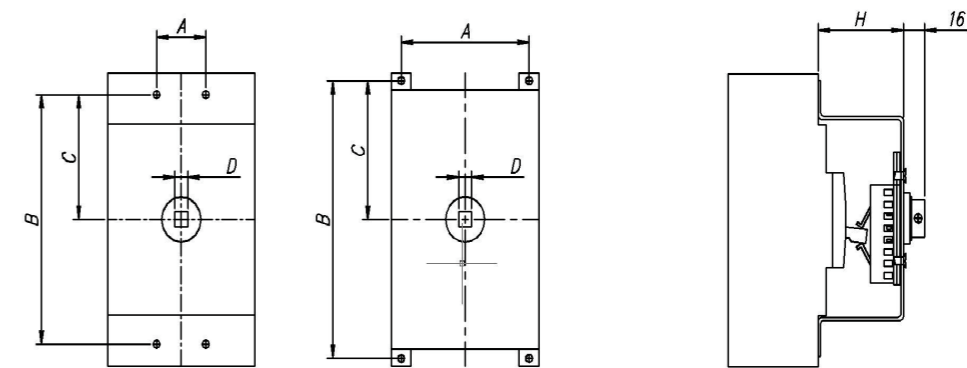

Code	Model number	A	B	C	D	H
1	CQM5-63/100	25	111	55	8	40
2	CQM5-125	30	132	66	8	44
3	CQM5-250	35	126	63	8	44
4	CQM5-400/630	138	195	97.5	10	70
5	CQM5-800	198	243	121.5	10	76

Code	Model number	A	B	C	D	H
1	CQM5L-125	30	132	66	8	44
2	CQM5L-250	35	126	63	8	44
3	CQM5L-400	138	195	97.5	10	70
4	CQM5L-630	198	243	121.5	10	76

Code	Model number	A	B	C	D	H
1	CQM5E-125	30	132	66	8	44
2	CQM5E-250	35	126	63	8	44
3	CQM5E-400	138	195	97.5	10	70
4	CQM5E-630	198	243	121.5	10	76
5	CQM5E-800	198	243	121.5	10	76

Note: General tolerance grade shall be in accordance with GB/T 1804-c.

The figure below shows the rotating handle and installation dimensions of the manual operating mechanism .

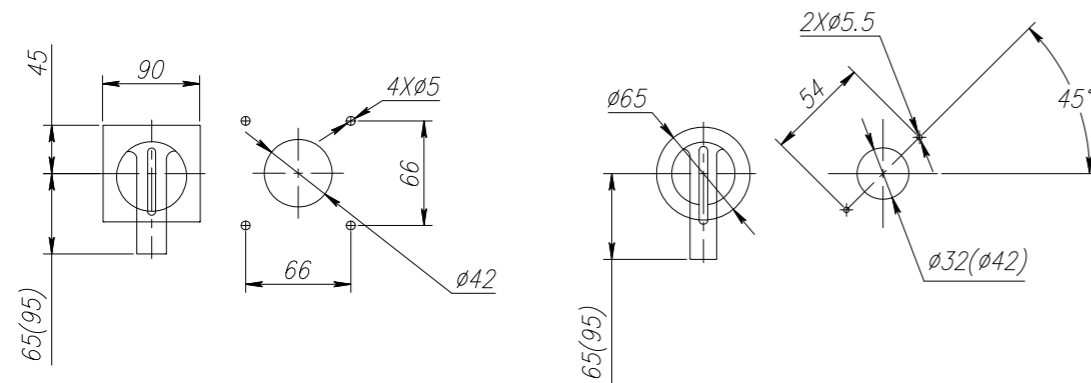

Handle Length Dimensions in the Figure:

For models CQM5-125/250: 65 mm or 95 mm (optional), with 65 mm as the default.
 For models CQM5-400/630/800: 95 mm.
 For models CQM5E-125/250: 65 mm or 95 mm (optional), with 65 mm as the default.
 For models CQM5E-400/630/800: 95 mm.
 For models CQM5L-125/250: 65 mm or 95 mm (optional), with 65 mm as the default.
 For models CQM5L-400/630/800: 95 mm.

2.3 Fixed Type Rear-Mounting Kit

Dimensions (mm)

CQM5 / CQM5E / CQM5L - 125/250

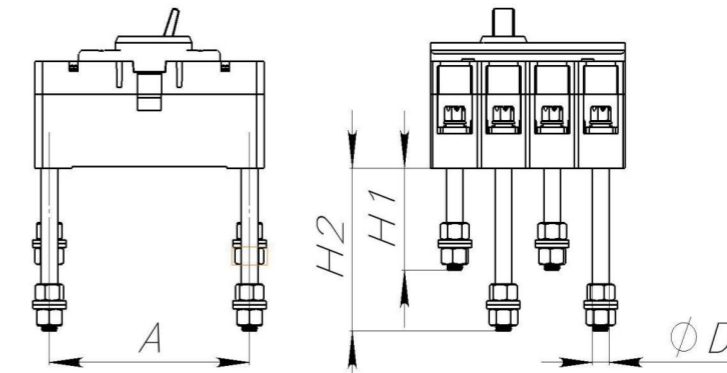

CQM5 / CQM5E / CQM5L - 400/630/800

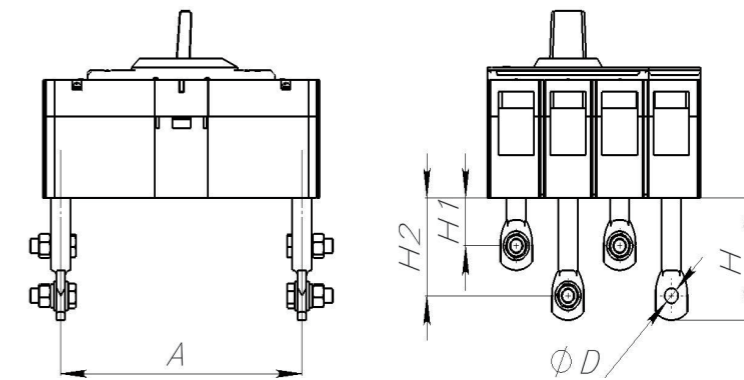

Code	Model number	A	H	H1	H2	D
1	CQM5-63/100	111	/	60.5	102.5	M8
2	CQM5-125	135	/	58	98	M8
3	CQM5-250	144	/	65	104	M8
4	CQM5-400/630	224	102	42	82	M12
5	CQM5-800	243	118	33	98	M16

Code	Model number	A	H	H1	H2	D
1	CQM5L-125	135	/	58	98	M8
2	CQM5L-250	144	/	65	104	M8
3	CQM5L-400	224	102	42	82	M12
4	CQM5L-630	243	118	33	98	M16

Code	Model number	A	H	H1	H2	D
1	CQM5E-125	135	/	58	98	M8
2	CQM5E-250	144	/	65	104	M8
3	CQM5E-400	224	102	42	82	M12
4	CQM5E-630	243	118	33	98	M16
5	CQM5E-800	243	118	33	98	M16

Note: General tolerance grade shall be in accordance with GB/T 1804-c.

2.4 Plug-in Type, Front-of-Panel

Dimensions (mm)

CQM5 / CQM5E / CQM5L-125/250

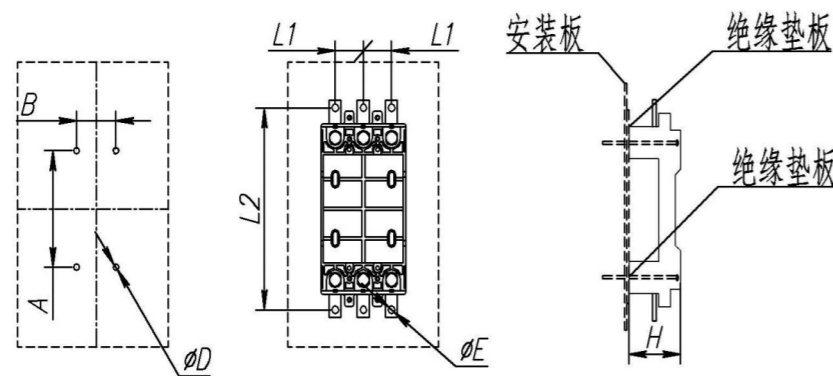

CQM5 / CQM5E / CQM5L-400

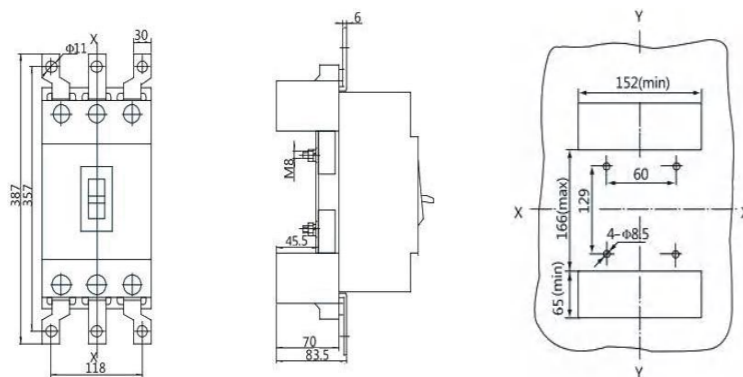

Code	Model number	A	B	L1	L2	D	E	H
1	CQM5-125	112	30	30	200	5.5	6.5	56
2	CQM5-250	150	35	35	223	5.5	8.5	73

Code	Model number	A	B	L1	L2	D	E	H
1	CQM5E-125	112	30	30	200	5.5	6.5	56
2	CQM5E-250	150	35	35	223	5.5	8.5	73

Code	Model number	A	B	L1	L2	D	E	H
1	CQM5L-125	112	30	30	200	5.5	6.5	56
2	CQM5L-250	150	35	35	223	5.5	8.5	73

Note: General tolerance grade shall be in accordance with GB/T 1804-c.

2.5 Plug-in Type, Rear-of-Panel

Dimensions (mm)

CQM5 / CQM5E / CQM5L-125/250

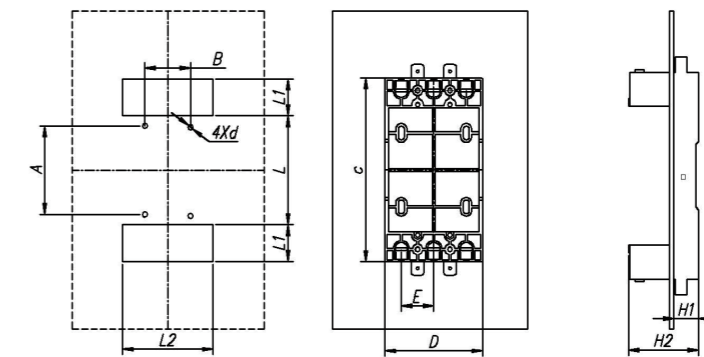

CQM5 / CQM5E / CQM5L-400

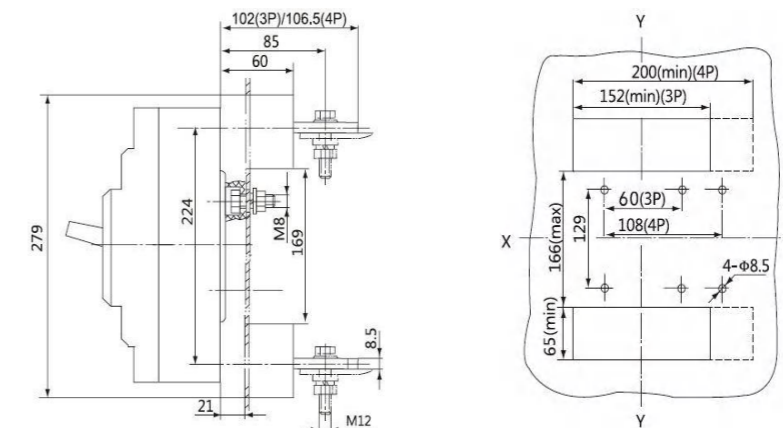

CQM5 / CQM5E / CQM5L-630/800

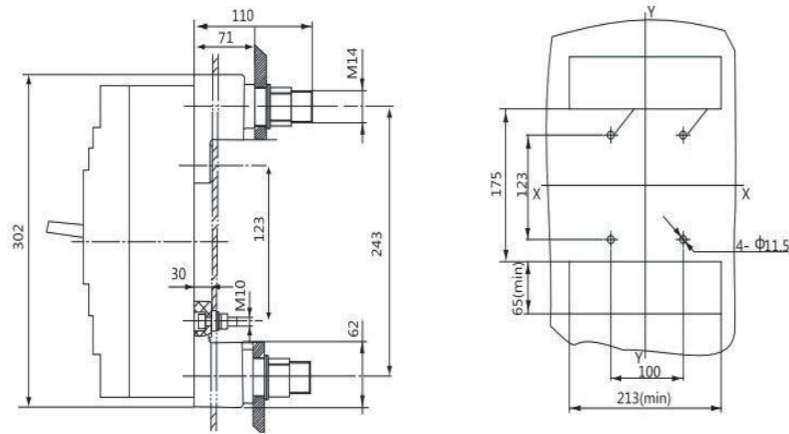

Code	Model number	A	B	L	L1	L2	d	C	D	E	H1	H2
1	CQM5-125	67	60	90	51	94	6.5	162	90	30	20	56
2	CQM5-250	74	70	100	55	110	6.5	179	105	35	27	73

Code	Model number	A	B	L	L1	L2	d	C	D	E	H1	H2
1	CQM5E-125	67	60	90	51	94	6.5	162	90	30	20	56
2	CQM5E-250	74	70	100	55	110	6.5	179	105	35	27	73

Code	Model number	A	B	L	L1	L2	d	C	D	E	H1	H2
1	CQM5L-125	67	60	90	51	94	6.5	162	90	30	20	56
2	CQM5L-250	74	70	100	55	110	6.5	179	105	35	27	73

Note: General tolerance grade shall be in accordance with GB/T 1804-c.

2.6 Mechanical Interlock

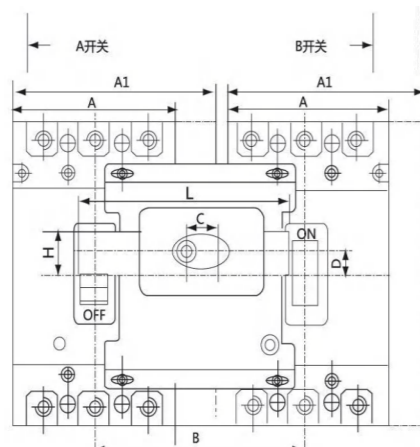

Parameter	CQM5-125	CQM5-250	CQM5-400	CQM5-630/800
A (3P)	90	105	150	210
B (3P)	120	130	180	243
C (3P)	45	50	57	58
D (3P)	14	16.5	10	20
L (3P)	134	140.5	190	240
H (3P)	22	22	30	20
A (4P)	120	140	198	280
B (4P)	150	170	230	310
C (4P)	45	50	57	58
D (4P)	14	16.5	10	20
L (4P)	164	233	240	320
H (4P)	22	22	30	30

Parameter	CQM5E-125	CQM5E-250	CQM5E-400	CQM5E-630/800
A (3P)	90	105	150	210
B (3P)	120	130	180	243
C (3P)	45	50	57	58
D (3P)	14	16.5	10	20
L (3P)	134	140.5	190	240
H (3P)	22	22	30	20
A (4P)	120	140	198	280
B (4P)	150	170	230	310
C (4P)	45	50	57	58
D (4P)	14	16.5	10	20
L (4P)	164	233	240	320
H (4P)	22	22	30	30

Parameter	CQM5L-125	CQM5L-250	CQM5L-400	CQM5L-630/800
A (3P)	90	105	150	210
B (3P)	120	130	180	243
C (3P)	45	50	57	58
D (3P)	14	16.5	10	20
L (3P)	134	140.5	190	240
H (3P)	22	22	30	20
A (4P)	120	140	198	280
B (4P)	150	170	230	310
C (4P)	45	50	57	58
D (4P)	14	16.5	10	20
L (4P)	164	233	240	320
H (4P)	22	22	30	30

Notes: a. Units: mm b. Undefined tolerances comply with GB/T 1804-2000 medium grade (m)

CQM6 Series

Molded case circuit breaker



Product Features

- Core Protection: Provides essential protection against overloads and short-circuits for distribution systems and motor circuits.
- Current Range: Comprehensive coverage from 10A up to 1250A.
- Compact Design: Features a miniaturized and unified footprint for easy panel integration and space savings.
- Accessory Flexibility: Supports a wide range of accessories (shunt trips, auxiliaries, etc.) for customized control and monitoring.

Compliance

- Meets international and regional standards including

IEC/EN 60947-1(General Rules)	GB/T 14048.1
IEC/EN 60947-2(Circuit-Breakers)	GB/T 14048.2
IEC/EN 60947-3(Switchgear)	GB/T 14048.3
IEC/EN 60947-4(Contactors & Motor-Starters)	GB/T 14048.4

Selection Guide

CQM6 - 125 C P / 4 300 - 125A 2 A Q1 D1 Q 2

Product code	Shell frame grade	Breaking capacity					Operating method	Operating method
		C	S	M	H			
CQM6	125	C	S	M	H	P	4	
Molded case circuit breaker	125	125	15/8	25/18	/	/	P:Motorized operation Z:Timing handle W:Direct operation	2-pole 3-pole 4-pole
	160	160	25/18	35/25	50/35	/		
	250	250	25/18	35/25	50/35	/		
	630	630	/	35/25	50/35	70/50		
	800	800	/	35/25	50/35	70/50		
	1250	1250	/	35/25	50/35	70/50		

Decoupler method and internal accessories	Rated current A	Function	Optional code for four-pole products
300	125A	2	A
The first digit indicates the type of detent 2:Instantaneous detent only 3:Duplicate detent Note:The last two digits are the accessory designator(see accessory table).	125	10,16,20,32,40,50,63,80,100,125	A:N-pole is unprotected and cannot be combined B:N-pole is unprotected and can be combined C:N-pole is protected and can be combined D:N-pole is protected and cannot be combined
	160	10,16,20,32,40,50,63,80,100,125,140,160	
	250	100,125,140,160,180,200,225,250	
	630	250,315,350,400,500,630	
	800	500,630,700,800	
	1250	800,1000,1250	

Accessory Voltage		Motorized operating voltage		Installation	Whether to install a terminal block	
Q1		D1		Q	2	
Undervoltage detent Q1:AC220V Q2:AC240V Q3:AC380V Q4:AC415V	Shunt release F1:AC220V F2:AC380V F3:DC110V F4:DC24V	Auxiliary alarm J1:AC125V J2:AC250V J3:DC125V J4:DC24V	DC1 Electrical Operation D1:AC220V D2:AC230V D3:AC380V D4:AC400V	DC3 Electrical Operation D5:AC230V D6:AC110V D7:DC220 D8:DC110 D9:AC110-240V D10:DC100-220V	Q:Front of plate H:Rear of plate C:Inserted	1:Noinstallation 2:Installation
Note:When motorized operation is selected,please refer to the external accessories for the two voltages applicable for motorized operation.						

Accessory List

Model number	CQM6-125	CQM6-160	CQM6-250	CQM6-630	CQM6-800	CQM6-1250
Breaking capacity	C,S	C,S,M	C,S,M	S,M,H	S,M,H	S,M,H
Number of poles	2,3,4	3,4	2,3,4	3,4	3,4	3,4
Accessory code	Accessory description					
208、308	Alarm Switch					
210、310	Shunt Release					
220、320	Auxiliary Switch					
230、330	Undervoltage Release					
240、340	Shunt Release and Auxiliary Switch					
240、250	Shunt Release and Undervoltage Release					
260、360	Two Auxiliary Switches					
270、370	Auxiliary Switch and Undervoltage Release					
218、318	Shunt Release and Alarm Switch					
228、328	Auxiliary Switch and Alarm Switch					
238、338	Undervoltage Release and Alarm Switch					
248、348	Shunt Release, Auxiliary Switch and Alarm Switch					
268、368	Two Auxiliary Switches and Alarm Switch					
278、378	Auxiliary Switch, Undervoltage Release and Alarm					
280、380	Two Auxiliary Switches and Shunt Release					

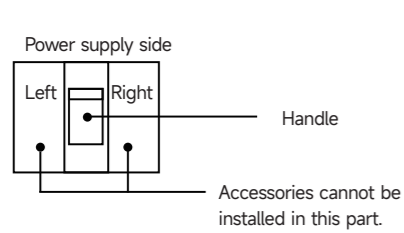

- Alarm switch
- Auxiliary switch
- Undervoltage release
- Shunt trip

- Our company can provide three new products for customers to choose from, namely the right-side auxiliary switch, the left-side shunt trip device, and the left-side undervoltage release device.
- For the specifications of 220, 320, 240, 340, 270 and 370, the auxiliary switch can provide two pairs of switches. Please specify this when placing an order.
- For the 250 and 350 specifications, the shunt trip device and undervoltage release for models 400 and above can only be installed on 3-pole circuit breakers.

Main Technical Parameters

Model number	CQM6-125			CQM6-160			
Rated current of frame level Inm(A)	125			160			
Number of poles	2, 3, 4			3, 4			
Rated current In(A), at 40°C, 50°C, 55°C	10, 16, 20, 25, 32, 40, 50, 63, 80, 100, 125			10, 16, 20, 25, 32, 40, 50, 63, 80, 100, 125, 140, 160			
Rated operating voltage Ue(V), AC 50/60Hz	400/415			400/415			
Rated insulation voltage Ui (V)	800			800			
Rated impulse withstand voltage Uimp(KV)	8			8			
Breaking capacity designation	C	S		C	S	M	
Short-circuit breaking capacity Icu/Ics(kA)	AC400/415V 15/8 25/18			25/18	35/25	50/35	
Selectivity category	A	A		A	A	A	
Number of operating cycles (cycle)	ON 6000 OFF 10000			6000 10000			
Trip mechanisms and protection types	Magnetic trip	Power distribution protection	●	●	●	●	
		Motor protection	●	●	●	●	
	Thermal-magnetic trip	Power distribution protection	●	●	●	●	
		Motor protection	●	●	●	●	
Auxiliary contacts		●	●	●	●	●	
Alarm contacts		●	●	●	●	●	
Shunt disconnect		●	●	●	●	●	
Undervoltage detent		●	●	●	●	●	
Manual operating mechanism		●	●	●	●	●	
Motorized operating mechanism		●	●	●	●	●	
Backplane wiring		●	●	●	●	●	
Inserted		●	●	●	●	●	
Coupling plate		●	●	●	●	●	
Partition between phases		●	●	●	●	●	
Derivative products	Dedicated for prepayment electric meters		●	●	●	●	
	Overload alarm without trip		-	-	-	●	●
Overall dimensions (mm) (a-b-c-ca)		3 P	75-130-68-92			90-155-70-94	90-155-84-109
		4 P	100-130-68-92			120-155-70-94	120-155-84-109

Note: ● for optional accessories; "-" for no optional accessories.

Main Technical Parameters

Model number	CQM6-250			CQM6-630		
Rated current of frame level Inm(A)	250			630		
Number of poles	2, 3, 4			3, 4		
Rated current In(A), at 40°C, 50°C, 55°C	125, 140, 160, 180, 200, 225, 250			250, 315, 350, 400, 500, 630		
Rated operating voltage Ue(V), AC 50/60Hz	400/415			400/415		
Rated insulation voltage Ui (V)	800			800		
Rated impulse withstand voltage Uimp(KV)	8			8		
Breaking capacity designation	C	S	M	S	M	H
Short-circuit breaking capacity Icu/Ics(kA)	AC400/415V 25/18 35/25 50/35			35/25	50/35	70/50
Selectivity category	A	A	A	A	A	A
Number of operating cycles (cycle)	ON 6000 OFF 10000			3000 8000		
Trip mechanisms and protection types	Magnetic trip	Power distribution protection	●	●	●	●
		Motor protection	●	●	●	●
	Thermal-magnetic trip	Power distribution protection	●	●	●	●
		Motor protection	●	●	●	●
Auxiliary contacts		●	●	●	●	●
Alarm contacts		●	●	●	●	●
Shunt disconnect		●	●	●	●	●
Undervoltage detent		●	●	●	●	●
Manual operating mechanism		●	●	●	●	●
Motorized operating mechanism		●	●	●	●	●
Backplane wiring		●	●	●	●	●
Inserted		●	●	●	●	●
Coupling plate		●	●	●	●	●
Partition between phases		●	●	●	●	●
Derivative products	Dedicated for prepayment electric meters		●	●	●	●
	Overload alarm without trip		●	●	●	●
Overall dimensions (mm) (a-b-c-ca)		3 P	105-165-70-96	105-165-93-120	140-257-105-155	
		4 P	140-165-70-96	140-165-93-120	185-257-105-155	

Note: ● for optional accessories; "-" for no optional accessories.

Main Technical Parameters

Model number		CQM6-800			CQM6-1250		
Rated current of frame level Inm(A)		800			1250		
Number of poles		3,4			3,4		
Rated current In(A),at 40°C,50°C,55°C		500, 630, 700, 800			1000, 1250		
Rated operating voltage Ue(V),AC 50/60Hz		400/415			400/415		
Rated insulation voltage Ui (V)		800			800		
Rated impulse withstand voltage Uimp(KV)		8			8		
Breaking capacity designation		S	M	H	S	M	H
Short-circuit breaking capacity Icu/Ics(kA) AC400/415V		35/25	50/35	70/50	25/18	35/25	70/50
Selectivity category		A	A	A	A	A	A
Number of operating cycles (cycle)		ON 3000			1000		
		OFF 8000			3000		
Trip mechanisms and protection types	Magnetic trip	Power distribution protection	●	●	●	●	●
		Motor protection	●	●	●	●	●
	Thermal-magnetic trip	Power distribution protection	●	●	●	●	●
		Motor protection	●	●	●	●	●
Accessory	Auxiliary contacts		●	●	●	●	●
	Alarm contacts		●	●	●	●	●
	Shunt disconnect		●	●	●	●	●
	Undervoltage detent		●	●	●	●	●
	Manual operating mechanism		●	●	●	●	●
	Motorized operating mechanism		●	●	●	●	●
	Backplane wiring		●	●	●	●	●
	Inserted		●	●	●	●	●
	Coupling plate		●	●	●	●	●
	Partition between phases		●	●	●	●	●
Derivative products	Dedicated for prepayment electric meters		●	●	●	●	●
	Overload alarm without trip		●	●	●	●	●
Overall dimensions (mm) (a-b-c-ca)		3 P	210-275-105-155			210-275-105-155	
		4 P	280-275-105-155			280-275-105-155	

Note: ● for optional accessories; "-" for no optional accessories.

Operating Characteristics

1. The inverse time operating characteristics of power distribution circuit breakers when all poles are energized simultaneously at an ambient air temperature of +40°C (with no humidity compensation) are shown in the following table:

Test current designation	Setting current multiple	Conventional time	Initial state
		$I_n \leq 63$ $63 < I_n$	
Conventional non-tripping current	1.05	$\geq 1h$ $\geq 2h$	Cool state
Conventional tripping current	1.30	$< 1h$ $< 2h$	Hot state

2. The inverse time action characteristics of circuit breakers for motor protection without humidity compensation when all poles are energized simultaneously at an ambient air temperature of +40°C are shown in the following table.

Test current designation	Setting current multiple	Conventional time	Initial state
		$I_n \leq 800$	
Conventional non-tripping current	1.0	$\geq 2h$	Cool state
Conventional tripping current	1.2	$< 2h$	Hot state

3. Action characteristics under short-circuit condition: The short-circuit current setting value of the instantaneous tripper of the circuit breaker for power distribution is $10I_n$.
The short-circuit current setting value of the instantaneous tripper of the circuit breaker for motor protection is $12I_n$.
The accuracy of the short-circuit current setting value of the instantaneous tripper is 20% of the short-circuit current setting value.

CQM6-125 Operating Characteristic Curve

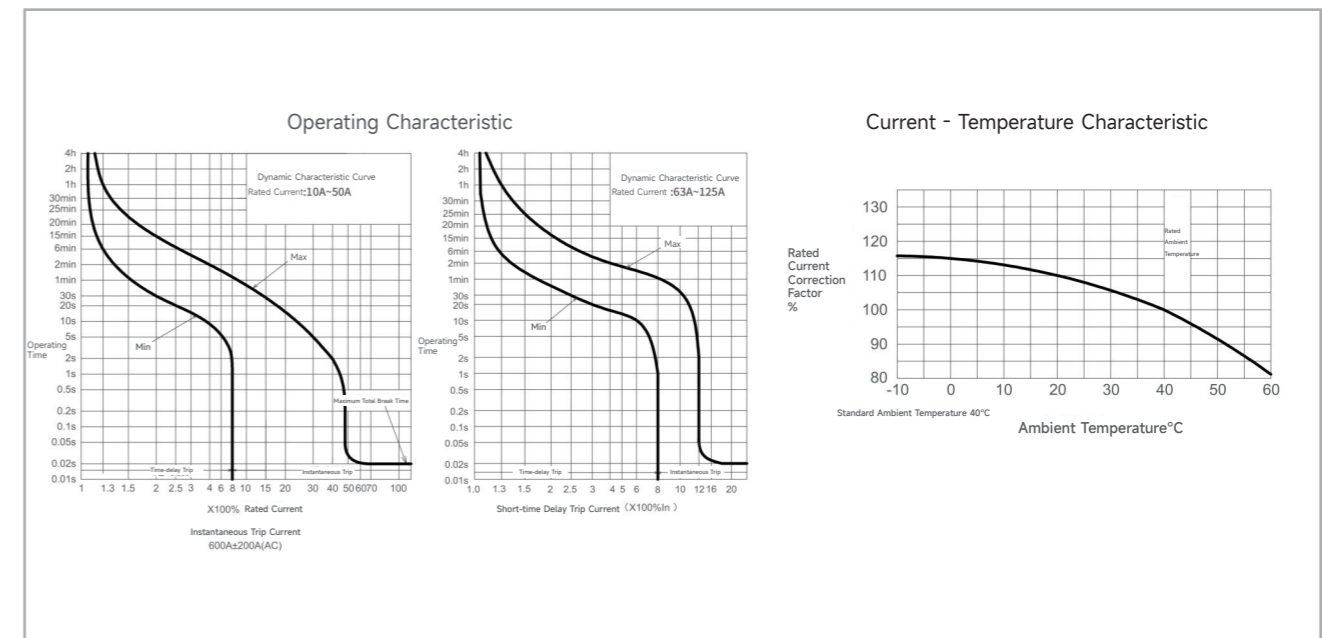

CQM6-160 Operating Characteristic Curve

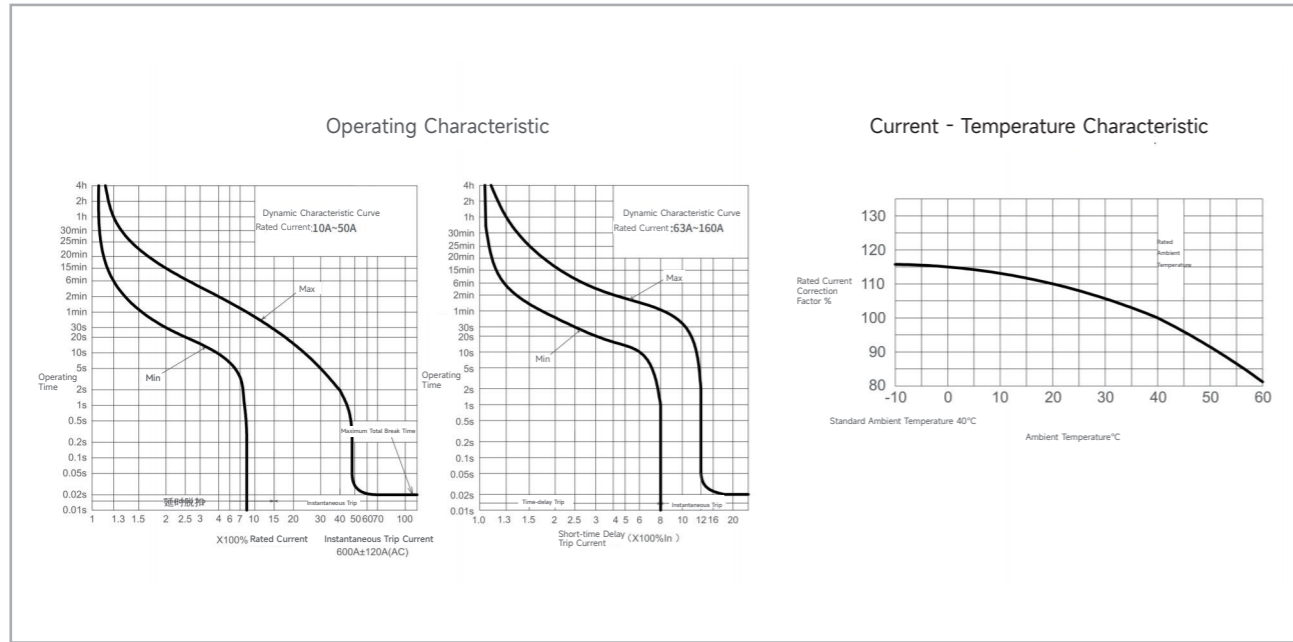

CQM6-630 Operating Characteristic Curve

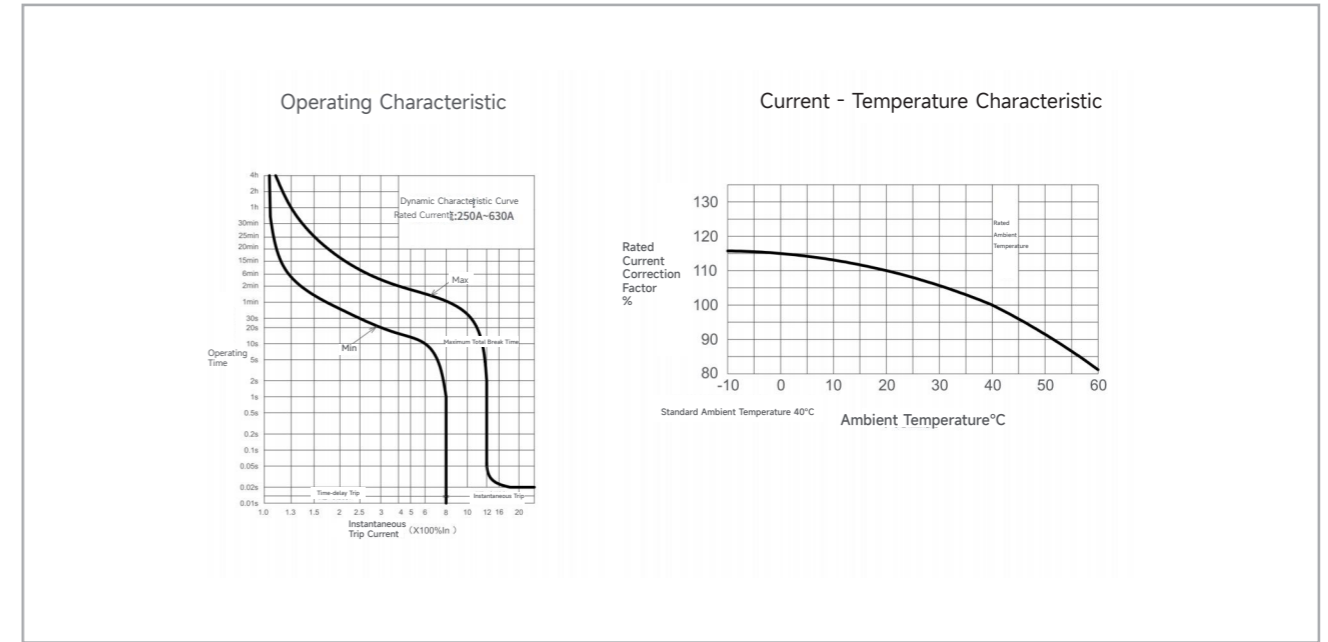

CQM6-250 Operating Characteristic Curve

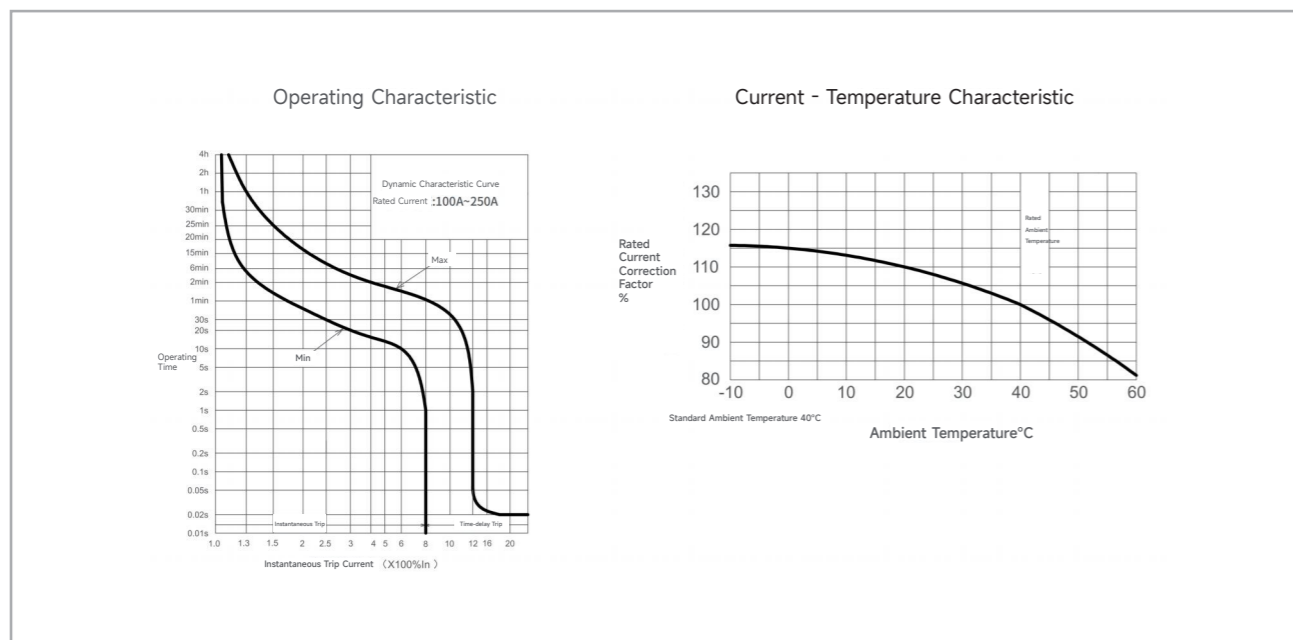

CQM6-800 Operating Characteristic Curve

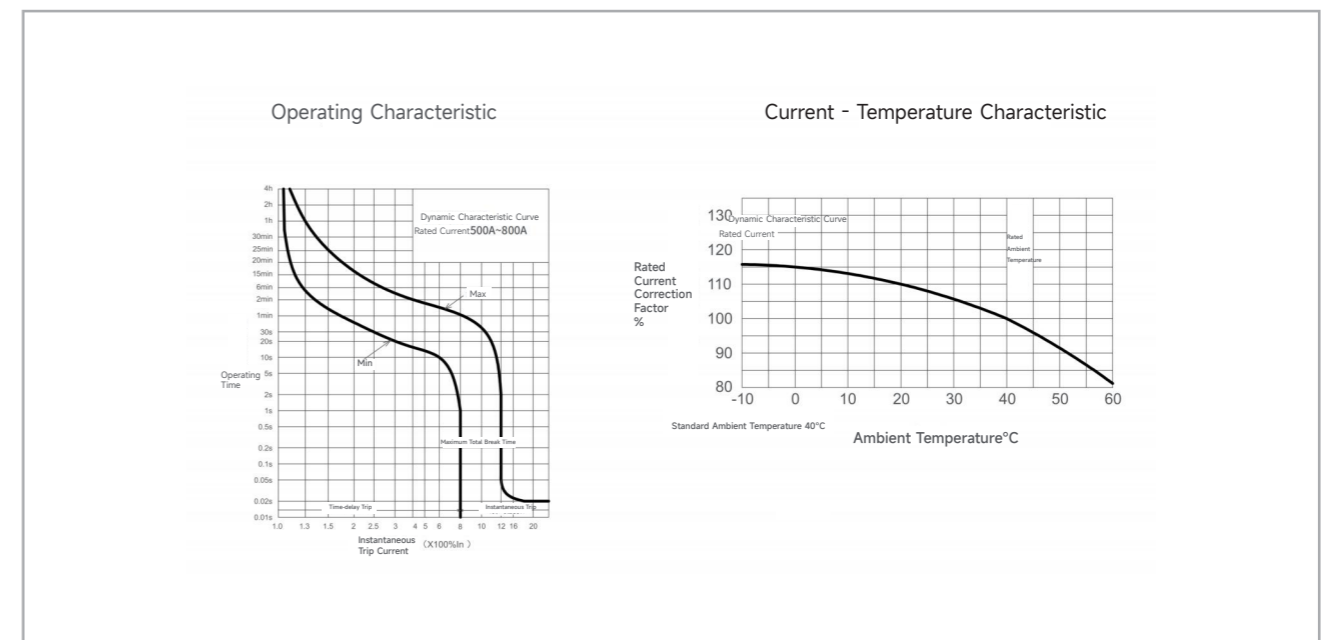

CQM6-1250 Operating Characteristic Curve

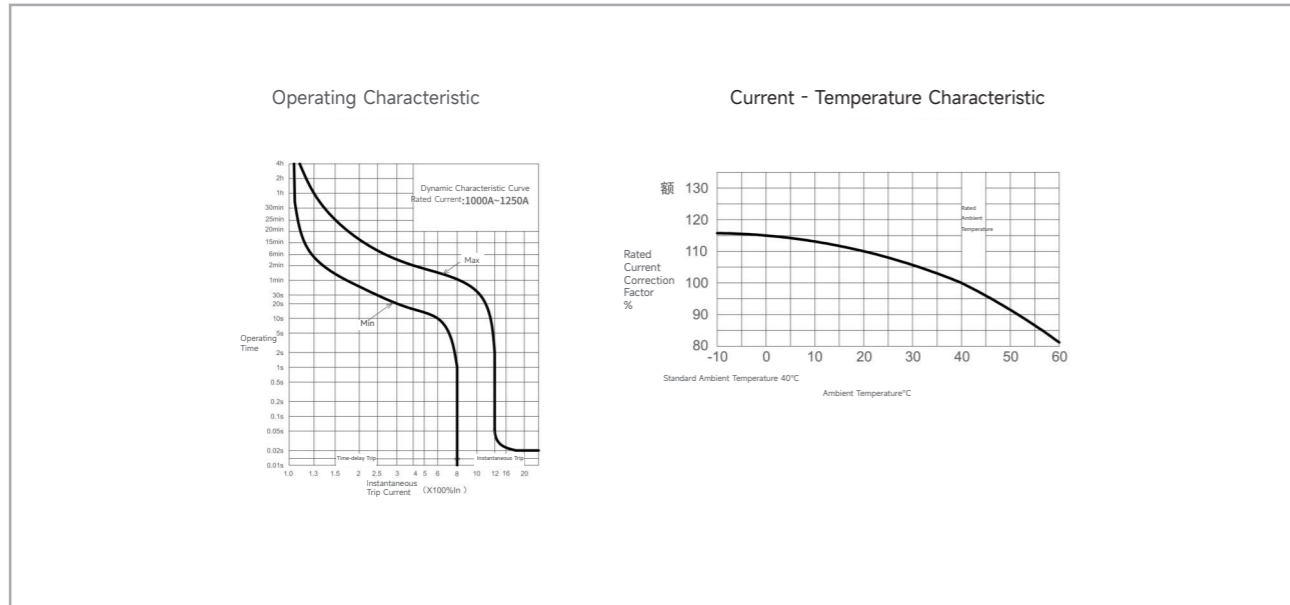

Outline and Installation Dimensions(mm)

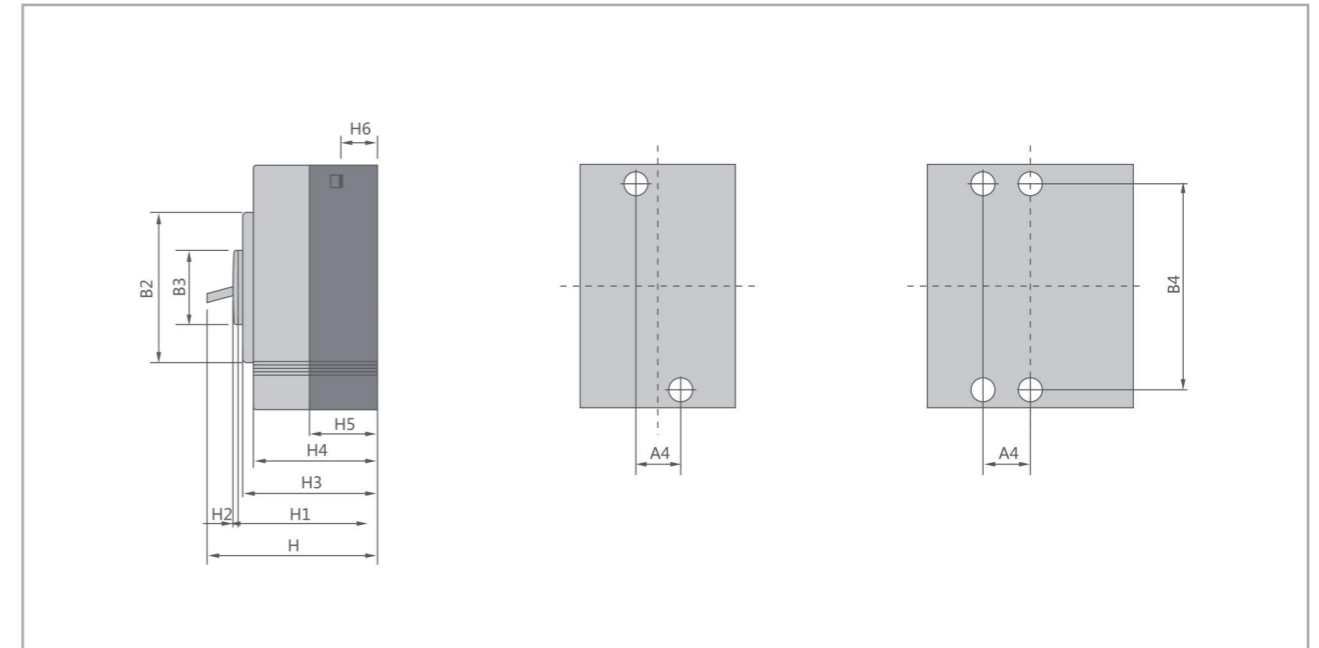

Outline and Installation Dimensions(mm)

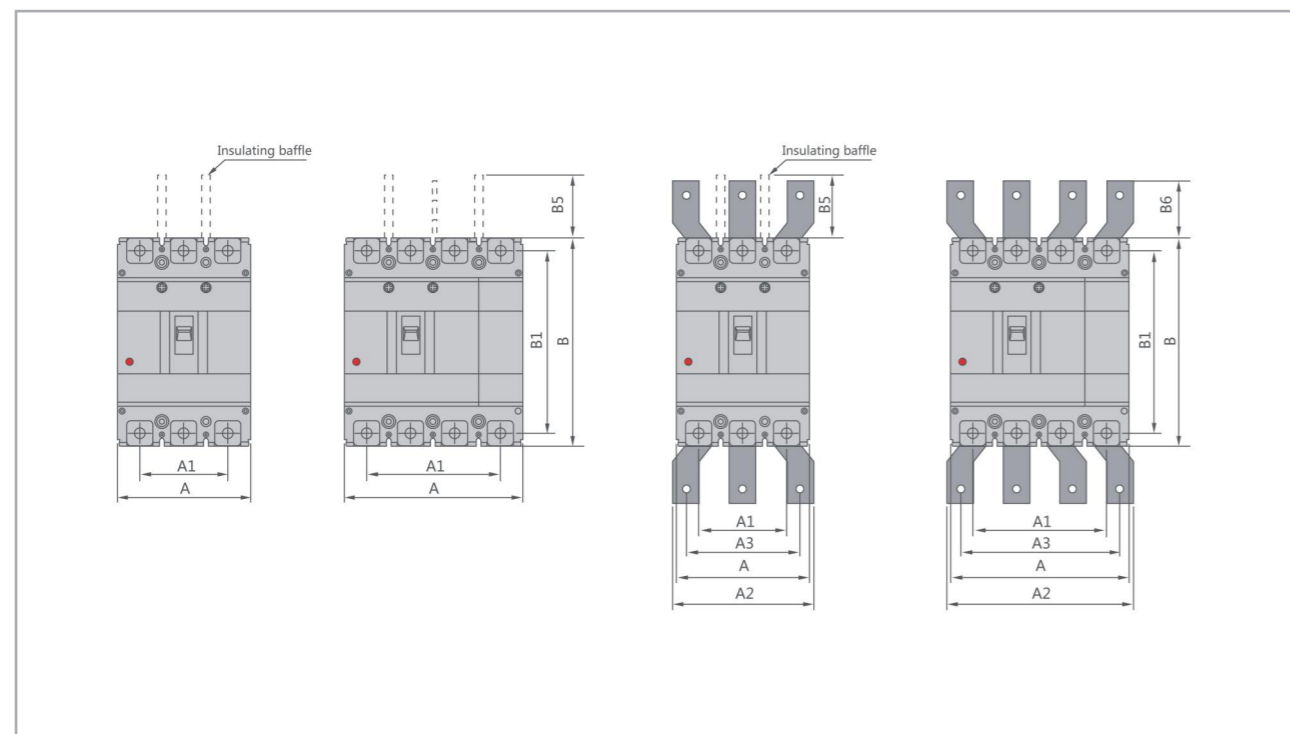

Molded case circuit breaker	Overall dimension																		Installation dimensions		Boit			
	A		A1		A2		A3		B	B1	B2	B3	B5	B6	H	H1	H2	H3	H4	H5		H6	A4	B4
	3P	4P	3P	4P	3P	4P	3P	4P																
CQM6-125CS	75	100	50	75	-	-	-	-	130	114	85	50	50	-	92	72	4	68	61	41	24	25	111	M8/M6
CQM6-160CS	90	120	60	90	-	-	-	-	155	134	103	50	50	-	94	72	4	70	61	41	24	30	132	M8
CQM6-160M	90	120	60	90	-	-	-	-	155	134	103	50	50	-	109	83	4	83	76	24.5	24.5	30	132	M8
CQM6-250CS	105	140	70	105	-	-	-	-	165	144	103	50	100	-	96	72	4	70	61	46	24	35	126	M8
CQM6-250M	105	140	70	105	-	-	-	-	165	144	102	50	110	-	120	95	4	91	84	22.5	24	35	126	M8
CQM6-630SMH	140	185	88	132	140	196	112	168	257	230	179	90	110	42	155	107	5	105	97	64	35	44	194	M10
CQM6-800SMH	210	280	140	210	180	250	140	210	275	243	192	90	110	87	155	107	5	104	97	65	24	70	242.5	M12
CQM6-1250SMH	210	280	140	210	180	250	140	210	275	243	192	90	110	87	155	107	5	104	97	65	24	70	242.5	M10*2

CQM6L Series

Residual current operated circuit breakers



Product Features

- **Integrated Safety:** Combines the overcurrent protection of a standard MCCB with earth leakage (RCCB) functionality in a single device for enhanced safety.
- **Seamless Compatibility:** Shares the same compact dimensions and accessory platform as the standard CQM6 series, allowing for easy upgrades.
- **Selective Tripping:** Offers configurable options for the N-pole (protected/unprotected, combinable) to meet specific system grounding requirements.
- **High Reliability:** Maintains the proven environmental resilience and mechanical durability of the CQM6 product line.

Compliance

- Meets international and regional standards including

IEC/EN 60947-1(General Rules)	GB/T 14048.1
IEC/EN 60947-2(Circuit-Breakers)	GB/T 14048.2
IEC/EN 60947-3(Switchgear)	GB/T 14048.3
IEC/EN 60947-4(Contactors & Motor-Starters)	GB/T 14048.4

Decoupler method and internal accessories	Rated current A	Function	Optional code for four-pole products
300	160A	2	A
The first digit indicates the type of detent 2:Instantaneous detent only 3:Duplicate detent Note:The last two digits are the accessory designator(see accessory table).	160	10,16,20,32,40,50,63,80,100,125,140,160	1:For power distribution 2:For motor protection A:N-pole is unprotected and cannot be combined B:N-pole is unprotected and can be combined C:N-pole is protected and can be combined D:N-pole is protected and cannot be combined
	250	100,125,140,160,180,200,225,250	
	630	250,315,350,400,500,630	
	800	500,630,700,800	

Product code	Breaking capacity
L1	Y1
Fixed delay type	Quick three-step adjustable
L1:30	L6:200
L2:50	L7:300
L3:75	L8:500
L4:100	L9:500
L5:150	L10:1000
	L11:30,50,100
	L12:30,100,200
	L13:30,100,500
	L14:100,300,500
	L15:100,300,500
	L16:100,300,1000
	Y1:0.1S
	Y4:0.4S
	Y7:0.7S
	Y10:1.0S
	Y13:0.45,1,2
	Y2:0.2S
	Y5:0.5S
	Y8:0.8S
	Y11:1.1S
	Y14:1,2,3
	Y3:0.3S
	Y6:0.6S
	Y9:0.9S
	Y12:1.2S

Selection Guide

CQM6L - 160 S P / 4 300 - 160A 2 A L1 Y1 Q1 D1 Q 2

Product code	Shell frame grade	Breaking capacity					Operating method	Operating method
		C	S	M	H			
CQM6L	160	C					P	4
Molded case circuit breaker	160	160	25/18	35/25	/	/	P:Motorized operation Z:Turning handle W:Direct operation	3-pole 4-pole
	250	250	25/18	35/25	/	/		
	630	630	/	35/25	50/35	75/75		
	800	800	/	35/25	50/35	75/75		
	1250	1250	/	35/25	50/35	75/75		

Accessory Voltage	Motorized operating voltage	Installation	Whether to install a terminal block
Q1	D1	Q	2
Undervoltage detent Q1:AC220V Q2:AC240V Q3:AC380V Q4:AC415V	Shunt release F1:AC220V F2:AC380V F3:DC110V F4:DC24V	Auxiliary alarm J1:AC125V J2:AC250V J3:DC125V J4:DC24V	DC1 Electrical Operation D1:AC220V D2:AC230V D3:AC380V D4:AC400V DC3 Electrical Operation D5:AC230V D6:AC110V D7:DC220 D8:DC110 D9:AC110-240V D10:DC100-220V
Note:When motorized operation is selected,please refer to the external accessories for the two voltages applicable for motorized operation.			
		Q:Front of plate H:Rear of plate C:Inserted	1:Noinstallation 2:Installation

Accessory List

Model number	CQM6L-160	CQM6L-250	CQM6L-630	CQM6L-800
Breaking capacity	C,S	C,S	S,M,H	S,M,H
Number of poles	4	4	3, 4	4
Accessory code				
208、308				
210、310				
220、320				
230、330				
240、340				
260、360				
270、370				
218、318				
228、328				
238、338				
248、348				
268、368				
278、378				
280、380				

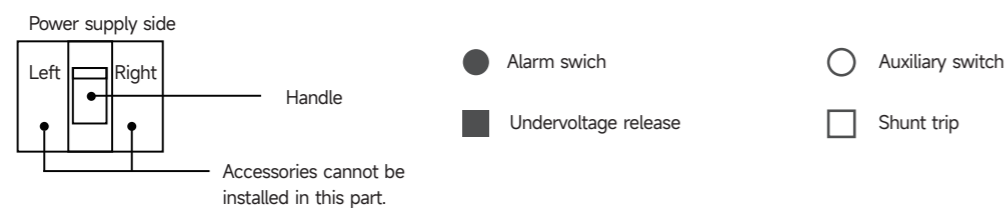

Main Technical Parameters

Model number	CQM6L-160	CQM6L-250				
Rated current of frame level Inm(A)	160	250				
Number of poles	4	4				
Rated current In(A),at 40°C,50°C,55°C	10, 16, 20, 32, 40, 50, 63, 80, 100, 125, 160	125,140,160,180,200,225,250				
Rated operating voltage Ue(V),AC 50/60Hz	400/415	400/415				
Rated insulation voltage Ui (V)	800	800				
Rated impulse withstand voltage Uimp(KV)	8	8				
Breaking capacity designation	C	S	C	S		
Short-circuit breaking capacity Icu/lcs(kA)	AC400/415V	25/18	35/25	25/18	35/25	
Selectivity category	A	A	A	A		
Number of operating cycles	ON	6000	6000			
(cycle)	OFF	10000	10000			
Trip mechanisms and protection types	Magnetic trip	Power distribution protection	●	●	●	●
		Motor protection	●	●	●	●
	Thermal-magnetic trip	Power distribution protection	●	●	●	●
		Motor protection	●	●	●	●
Accessory	Auxiliary contacts	●	●	●	●	
	Alarm contacts	●	●	●	●	
	Shunt disconnect	●	●	●	●	
	Undervoltage detent	●	●	●	●	
	Manual operating mechanism	●	●	●	●	
	Motorized operating mechanism	●	●	●	●	
	Backplane wiring	●	●	●	●	
	Inserted	●	●	●	●	
	Coupling plate	●	●	●	●	
	Partition between phases	●	●	●	●	
Derivative products	Dedicated for prepayment electric meters	●	●	●	●	
	Overload alarm without trip	●	●	●	●	
Overall dimensions (mm) (a-b-c-ca)	4 P	120-155-70-94	140-165-70-96			

Note: ● for optional accessories; "-" for no optional accessories.

Main Technical Parameters

Model number		CQM6L-630			CQM6L-800		
Rated current of frame level Inm(A)		630			800		
Number of poles		3, 4			4		
Rated current In(A), at 40°C, 50°C, 55°C		250, 315, 350, 400, 500, 630			500, 630, 700, 800		
Rated operating voltage Ue(V), AC 50/60Hz		400/415			400/415		
Rated insulation voltage Ui (V)		800			800		
Rated impulse withstand voltage Uimp(KV)		8			8		
Breaking capacity designation		S	M	H	S	M	H
Short-circuit breaking capacity Icu/Ics(kA)		AC400/415V 35/25 50/35 75/75			35/25 50/35 75/75		
Selectivity category		A	A	A	A	A	A
Number of operating cycles (cycle)		ON 3000 OFF 8000			3000 8000		
Trip mechanisms and protection types	Magnetic trip	Power distribution protection	●	●	●	●	●
		Motor protection	●	●	●	●	●
	Thermal-magnetic trip	Power distribution protection	●	●	●	●	●
		Motor protection	●	●	●	●	●
Accessory		Auxiliary contacts	●	●	●	●	●
		Alarm contacts	●	●	●	●	●
		Shunt disconnect	●	●	●	●	●
		Undervoltage detent	●	●	●	●	●
		Manual operating mechanism	●	●	●	●	●
		Motorized operating mechanism	●	●	●	●	●
		Backplane wiring	●	●	●	●	●
		Inserted	●	●	●	●	●
		Coupling plate	●	●	●	●	●
		Partition between phases	●	●	●	●	●
Derivative products		Dedicated for prepayment electric meters	●	●	●	●	●
		Overload alarm without trip	●	●	●	●	●
Overall dimensions (mm) (a-b-c-ca)			4 P	185-257-105-155	280-275-105-155		

Note: ● for optional accessories; "-" for no optional accessories.

Operating Characteristics

1. The inverse time operating characteristics of power distribution circuit breakers when all poles are energized simultaneously at an ambient air temperature of +40°C (with no humidity compensation) are shown in the following table:

Test current designation	Setting current multiple	Conventional time	Initial state
		In ≤ 63 In > 63	
Conventional non-tripping current	1.05	≥ 1h ≥ 2h	Cool state
Conventional tripping current	1.30	< 1h < 2h	Hot state

2. The inverse time action characteristics of circuit breakers for motor protection without humidity compensation when all poles are energized simultaneously at an ambient air temperature of +40°C are shown in the following table:

Test current designation	Setting current multiple	Conventional time	Initial state
		In ≤ 800	
Conventional non-tripping current	1.0	≥ 2h	Cool state
Conventional tripping current	1.2	< 2h	Hot state

3. Action characteristics under short-circuit condition: The short-circuit current setting value of the instantaneous tripper of the circuit breaker for power distribution is 10In. The short-circuit current setting value of the instantaneous tripper of the circuit breaker for motor protection is 12In. The accuracy of the short-circuit current setting value of the instantaneous tripper is 20% of the short-circuit current setting value.

CQM6L-125 Operating Characteristic Curve

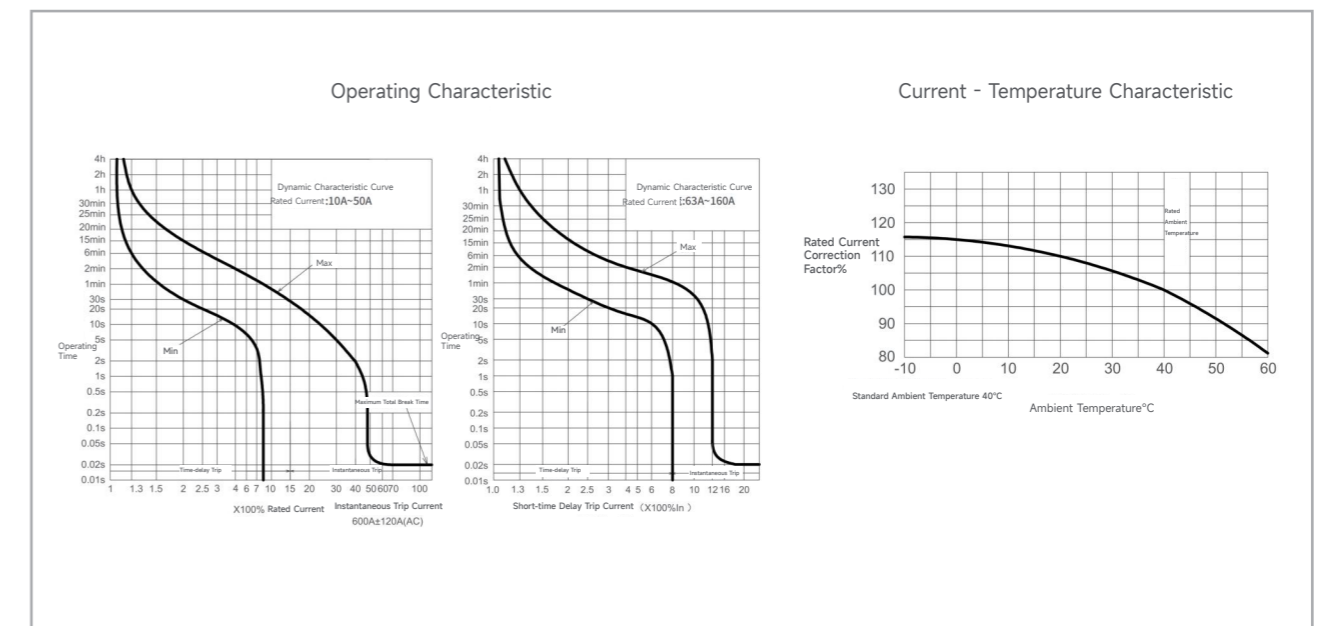

CQM6L-250 Operating Characteristic Curve

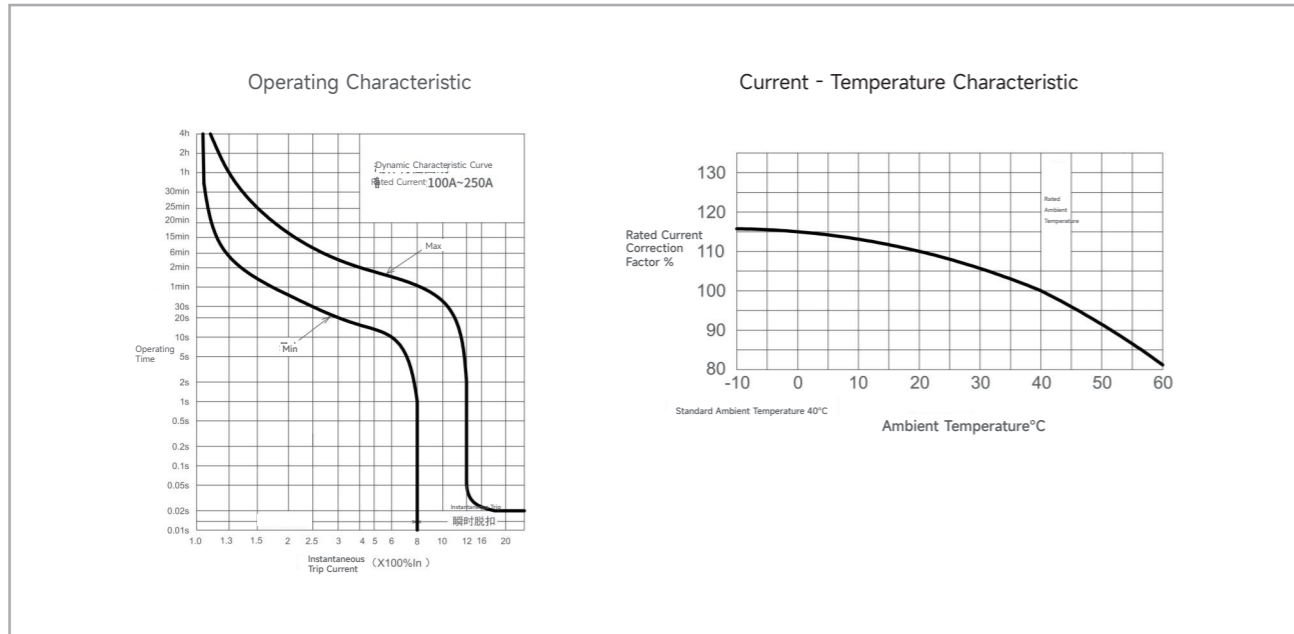

CQM6L-800 Operating Characteristic Curve

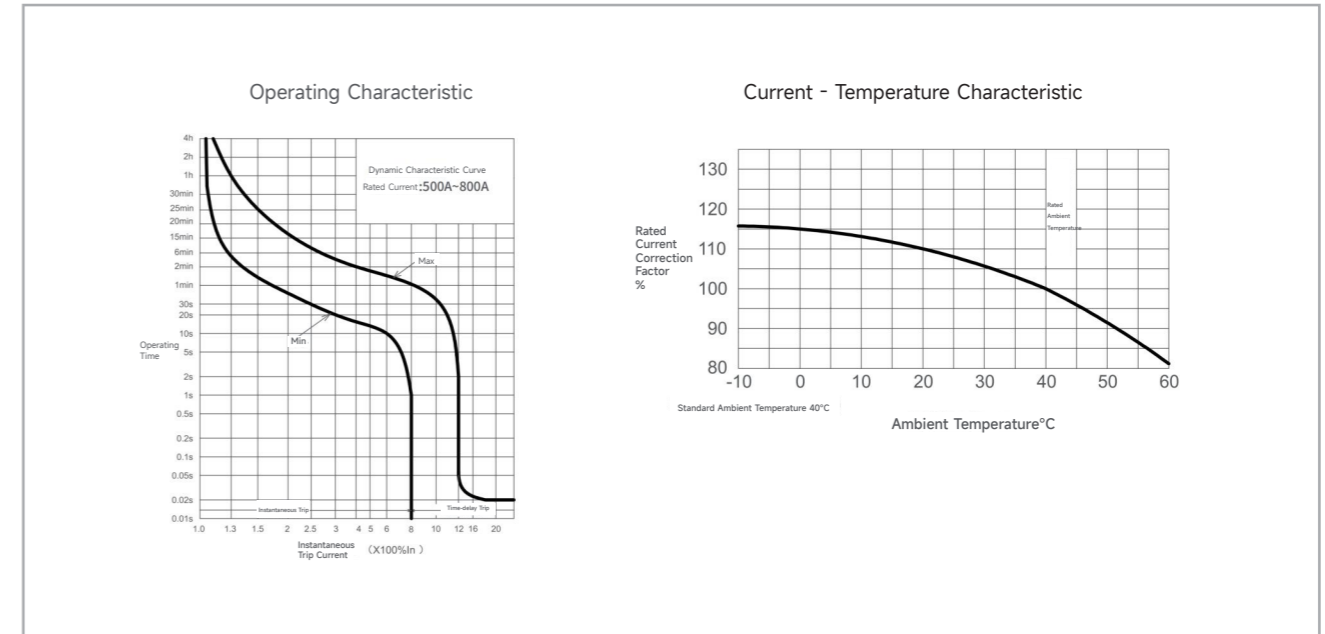

CQM6L-630 Operating Characteristic Curve

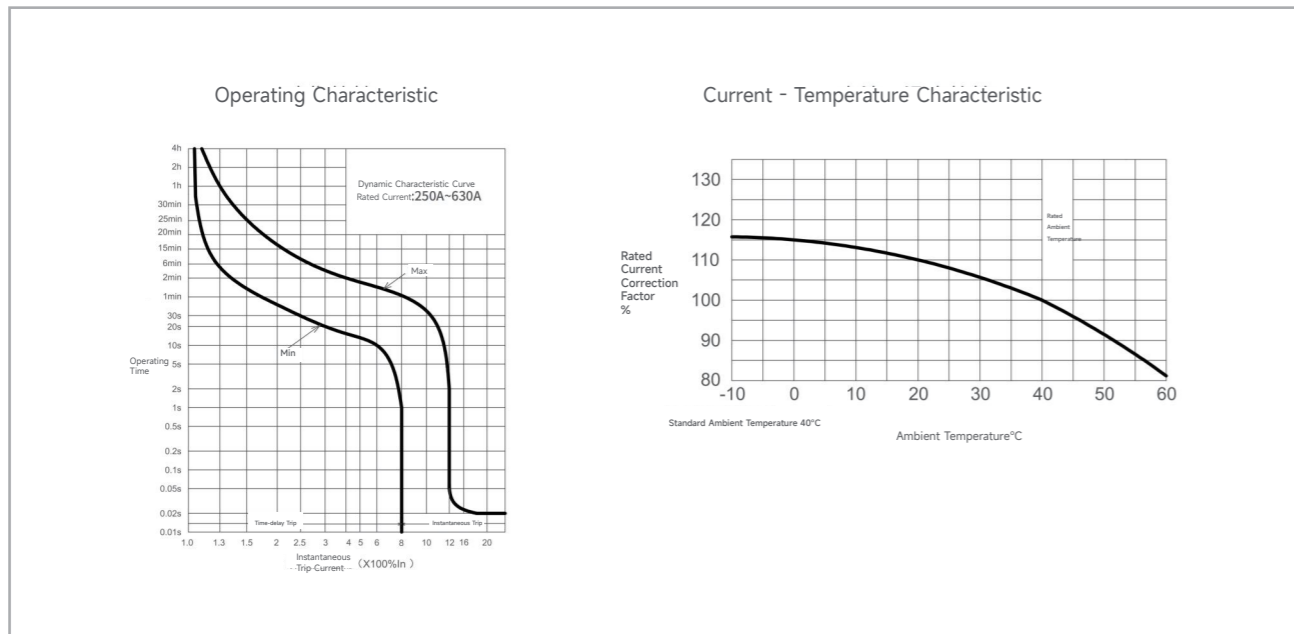

CQM6L-1250 Operating Characteristic Curve

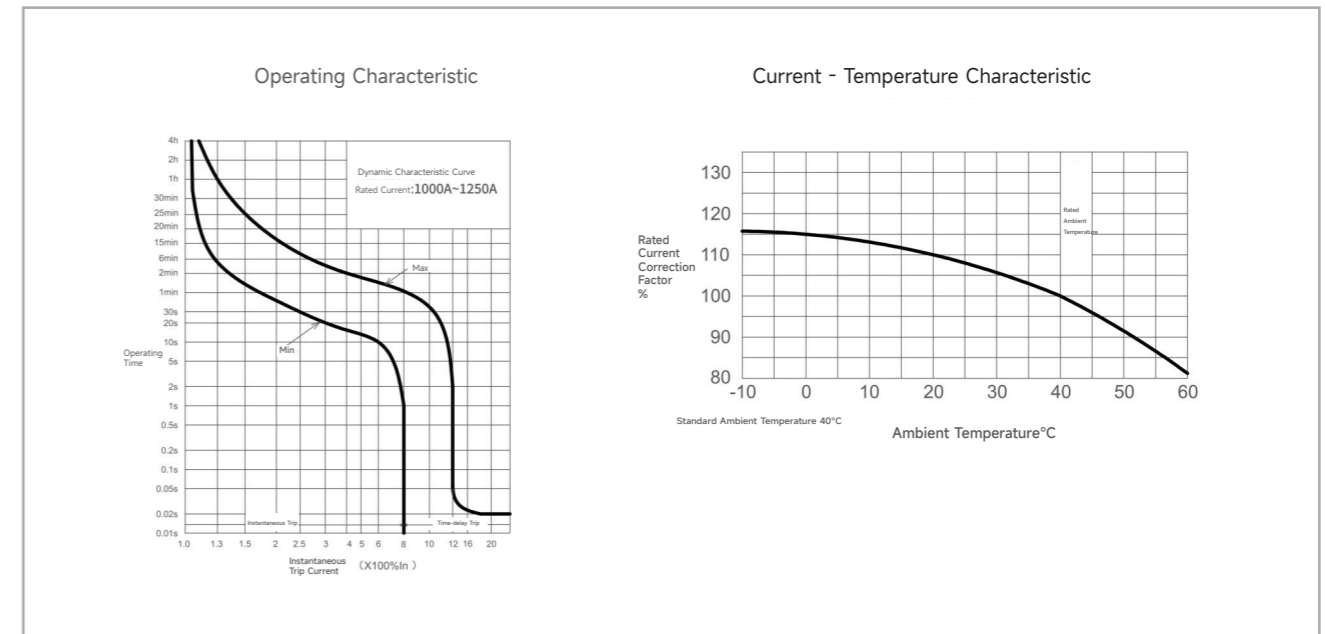

Outline and Installation Dimensions(mm)

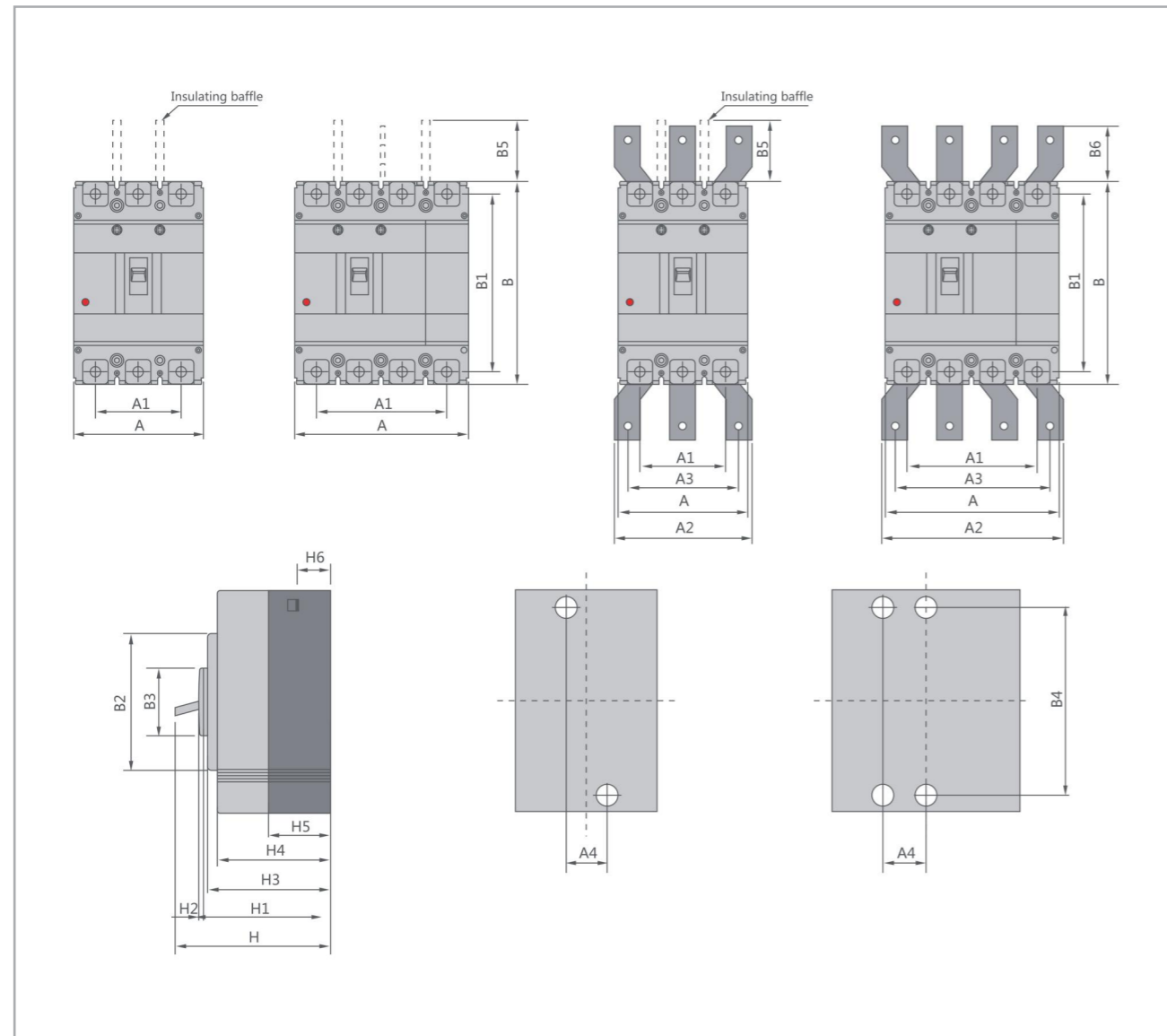

Molded case circuit breaker	Overall dimension																	Installation dimensions		Boit				
	A		A1		A2		A3		B	B1	B2	B3	B5	B6	H	H1	H2	H3	H4		H5	H6	A4	B4
	3P	4P	3P	4P	3P	4P	3P	4P																
CQM6L-160	-	120	-	90	-	-	-	-	155	134	103	50	50	-	94	72	4	70	61	41	24	30	132	M8
CQM6L-250	-	140	-	105	-	-	-	-	165	144	103	50	100	-	96	72	4	70	61	46	24	35	126	M8
CQM6L-630	-	185	-	132	-	196	-	168	257	230	179	90	110	42	155	107	5	105	97	64	35	44	194	M10
CQM6L-800	-	280	-	210	-	250	-	210	275	243	192	90	110	87	155	107	5	104	97	65	24	70	242.5	M12

CQM6T/A, RT Series
Molded case circuit breaker



Product Features

- Field-Adjustable Settings: Allows for precise on-site customization of both overload (I_r) and short-circuit (I_m) protection settings for optimized coordination.
- Dual Protection Curves: Available with trip units optimized for either "Power Distribution" or "Motor Protection" applications.
- Proven Robustness: Designed for reliable operation across a wide temperature range (-35°C to +70°C) and at high altitudes up to 2000m.
- Accessory Compatibility: Supports a full range of accessories, including shunt releases and undervoltage trips, for extended control capabilities.

Compliance

- Meets international and regional standards including

IEC/EN 60947-1(General Rules)	GB/T 14048.1
IEC/EN 60947-2(Circuit-Breakers)	GB/T 14048.2
IEC/EN 60947-3(Switchgear)	GB/T 14048.3
IEC/EN 60947-4(Contactors & Motor-Starters)	GB/T 14048.4

Selection Guide

CQM6 RT - 160 H Z / 3 300 2 A Q1 D Q 2

Product code	Shell frame grade	Breaking capacity	Operating method				
CQM6	RT	160	C				
Molded case circuit breaker	RT stands for thermomagnetically adjustable T, A stands for single adjustable (i.e.,thermally adjustable/magnetically fixed).		C	S	M	H	
		160	160	25/18	35/25	50/35	/
		250	250	25/18	35/25	50/35	/
		630	630	/	35/25	50/35	75/75
		800	/	35/25	50/35	75/75	

Operating method	The number of poles	Decoupler method and internal accessories	Rated current A	
P	4	300	125A	
P:Motorized operation Z:Turn the handle W:Direct operation D:Electric operation DC1DC 2,DC3	2: 2-pole 3: 3-pole 4: 4-pole	The first digit indicates the type of detent 2:Instantaneous detent only 3:Duplicate detent Note:The last two digits are the accessory designator(see accessory table).	160	32,40,50,63,80,100,125,140,160
			250	100,125,140,160,180,200,225,250
			630	250,315,350,400,500,630
			800	500,630,700,800

Application	Optional code for Level 4 products
2	A
1:For power distribution	A:N-pole unprotected,not combinable A
2:For motor protection	B:N-pole unprotected,combinable

Accessory Voltage			Motorized operating voltage		Installation	Whether to install a terminal block
Q1			D1		Q	2
Undervoltage detent UVT	Shunt release Shunt	Auxiliary alarm Auxiliary	DC1	DC3 D5:AC230V	Q:Front of plate H:Rear of plate C:Inserted	1:No installation 2:Installation
Q1:AC220V	F1:AC220V	J1:AC125V	D1:AC220V	D6:AC110V		
Q2:AC240V	F2:AC380V	J2:AC250V	D2:AC230V	D7:DC220V		
Q3:AC380V	F3:DC110V	J3:DC125V	D3:AC380V	D8:DC110V		
			D4:AC400V	D9:AC110-240V		
				D10:DC100-220V		
Q4:AC415V	F4:DC24V	J4:DC24V				

Accessory List

Model number		CQM6T/A.RT-160	CQM6T/A.RT-250	CQM6T/A.RT-630	CQM6T/A.RT-800
Breaking capacity		C,S,M	C,S,M	S,M,H	S,M,H
Number of poles		3,4	3,4	3,4	3,4
Accessory code					
208、308	Alarm Switch				
210、310	Shunt Release				
220、320	Auxiliary Switch				
230、330	Undervoltage Release				
240、340	Shunt Release and Auxiliary Switch				
260、360	Two Auxiliary Switches				
270、370	Auxiliary Switch and Undervoltage Release				
218、318	Shunt Release and Alarm Switch				
228、328	Auxiliary Switch and Alarm Switch				
238、338	Undervoltage Release and Alarm Switch				
248、348	Shunt Release, Auxiliary Switch and Alarm Switch				
268、368	Two Auxiliary Switches and Alarm Switch				
278、378	Auxiliary Switch, Undervoltage Release and Alarm				
280、380	Two Auxiliary Switches and Shunt Release				

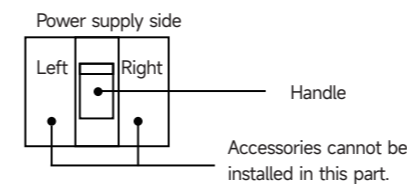

- Alarm switch
- Auxiliary switch
- Undervoltage release
- Shunt trip

- MH can provide three new products right auxiliary switch, left shunt and left undervoltage for customers to choose.
- In 220,320,240,340,270,370 specifications, the auxiliary switch can be used for Mopairs of switches, which should be specified when ordering.

Main Technical Parameters

Model number		CQM6T/A.RT-160			CQM6T/A.RT-250		
Rated current of frame level Inm(A)		160			250		
Number of poles		3, 4			3, 4		
Rated current In(A),at 40°C,50°C,55°C		63,80,100,125,160			125,140,160,180,200,225,250		
Rated operating voltage Ue(V),AC 50/60Hz		400/415			400/415		
Rated insulation voltage Ui (V)		800			800		
Rated impulse withstand voltage Uimp(KV)		8			8		
Breaking capacity designation		C	S	M	C	S	M
Short-circuit breaking capacity Icu/Ics(kA) AC400/415V		25/18	35/25	50/35	25/18	35/25	50/35
Selectivity category		A	A	A	A	A	A
Number of operating cycles (cycle)		ON 6000			OFF 10000		
Trip mechanisms and protection types	Magnetic trip	Power distribution protection	●	●	●	●	●
		Motor protection	●	●	●	●	●
	Thermal-magnetic trip	Power distribution protection	●	●	●	●	●
		Motor protection	●	●	●	●	●
Accessory		Auxiliary contacts	●	●	●	●	●
		Alarm contacts	●	●	●	●	●
		Shunt disconnect	●	●	●	●	●
		Undervoltage detent	●	●	●	●	●
		Manual operating mechanism	●	●	●	●	●
		Motorized operating mechanism	●	●	●	●	●
		Backplane wiring	●	●	●	●	●
		Inserted	●	●	●	●	●
		Coupling plate	●	●	●	●	●
		Partition between phases	●	●	●	●	●
Derivative products		Dedicated for prepayment electric meters	●	●	●	●	●
		Overload alarm without trip	●	●	●	●	●
Overall dimensions (mm) (a-b-c-ca)			3 P	90-155-70-94	90-155-84-109	105-165-70-96	105-165-93-120
			4 P	120-155-70-94	120-155-84-109	140-165-70-96	140-165-93-120

Note: ● for optional accessories; “-” for no optional accessories.

Main Technical Parameters

Model number		CQM6T/A.RT-630			CQM6T/A.RT-800		
Rated current of frame level Inm(A)		630			800		
Number of poles		3,4			3,4		
Rated current In(A),at 40°C,50°C,55°C		250,315,350,400,500,630			500,630,700,800		
Rated operating voltage Ue(V),AC 50/60Hz		400/415			400/415		
Rated insulation voltage Ui (V)		800			800		
Rated impulse withstand voltage Uimp(KV)		8			8		
Breaking capacity designation		S	M	H	S	M	H
Short-circuit breaking capacity Icu/Ics(kA) AC400/415V		35/25	50/35	75/75	35/25	50/35	75/75
Selectivity category		A	A	A	A	A	A
Number of operating cycles (cycle)		ON 3000			OFF 8000		
Trip mechanisms and protection types	Magnetic trip	Power distribution protection	●	●	●	●	●
		Motor protection	●	●	●	●	●
	Thermal-magnetic trip	Power distribution protection	●	●	●	●	●
		Motor protection	●	●	●	●	●
Accessory		Auxiliary contacts	●	●	●	●	●
		Alarm contacts	●	●	●	●	●
		Shunt disconnect	●	●	●	●	●
		Undervoltage detent	●	●	●	●	●
		Manual operating mechanism	●	●	●	●	●
		Motorized operating mechanism	●	●	●	●	●
		Backplane wiring	●	●	●	●	●
		Inserted	●	●	●	●	●
		Coupling plate	●	●	●	●	●
		Partition between phases	●	●	●	●	●
Derivative products		Dedicated for prepayment electric meters	●	●	●	●	●
		Overload alarm without trip	●	●	●	●	●
Overall dimensions (mm) (a-b-c-ca)			3 P	210-275-105-155			210-275-105-155
			4 P	280-275-105-155			280-275-105-155

Note: ● for optional accessories; “-” for no optional accessories.

Operating Characteristics

1. The inverse time operating characteristics of power distribution circuit breakers when all poles are energized simultaneously at an ambient air temperature of +40°C (with no humidity compensation) are shown in the following table:

Test current designation	Setting current multiple	Conventional time	Initial state
		$I_n \leq 63$ $I_n > 63$	
Conventional non-tripping current	1.05	$\geq 1h$ $\geq 2h$	Cool state
Conventional tripping current	1.30	$< 1h$ $< 2h$	Hot state

2. The inverse time action characteristics of circuit breakers for motor protection without humidity compensation when all poles are reenergized simultaneously at an ambient air temperature of +40°C are shown in the following table.

Test current designation	Setting current multiple	Conventional time	Initial state
		$I_n \leq 800$	
Conventional non-tripping current	1.0	$\geq 2h$	Cool state
Conventional tripping current	1.2	$< 2h$	Hot state

3. Action characteristics under short-circuit condition: The short-circuit current setting value of the instantaneous tripper of the circuit breaker for power distribution is $10I_n$.
The short-circuit current setting value of the instantaneous tripper of the circuit breaker for motor protection is $12I_n$.
The accuracy of the short-circuit current setting value of the instantaneous tripper is 20% of the short-circuit current setting value.

CQMGT/A.RT-160 Operating Characteristic Curve

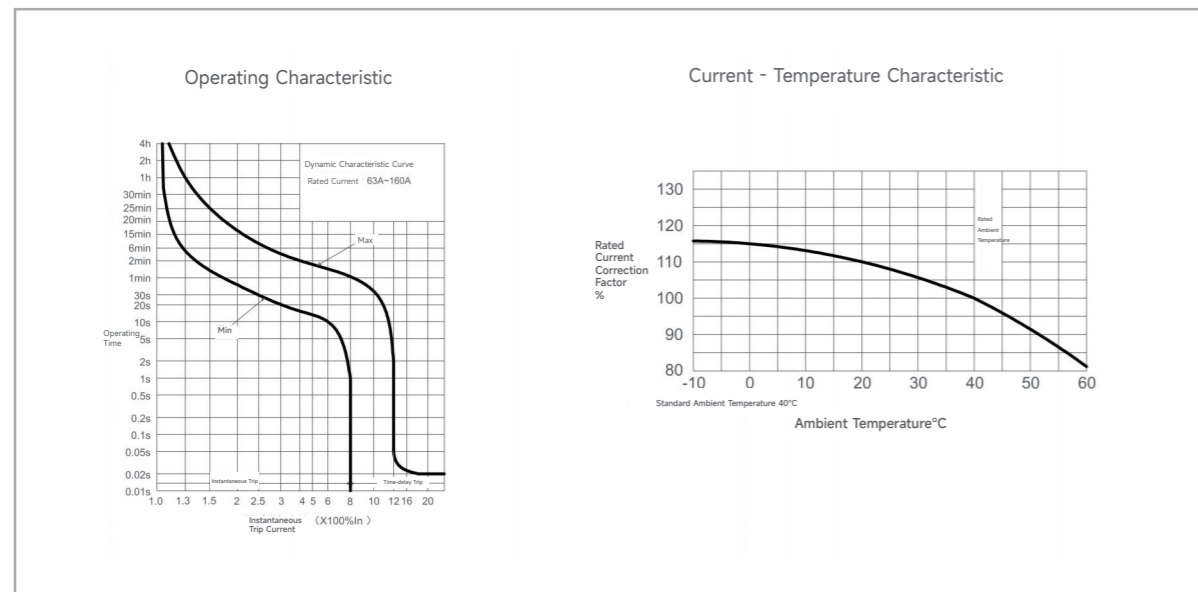

CQMGT/A.RT-250 Operating Characteristic Curve

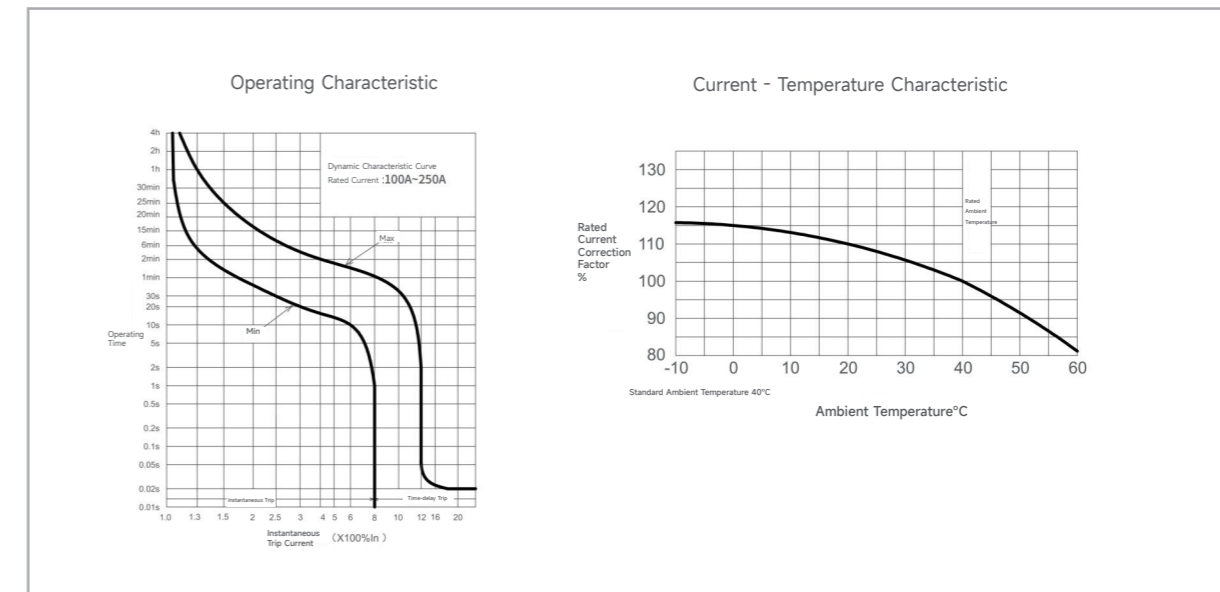

CQMGT/A.RT-630 Operating Characteristic Curve

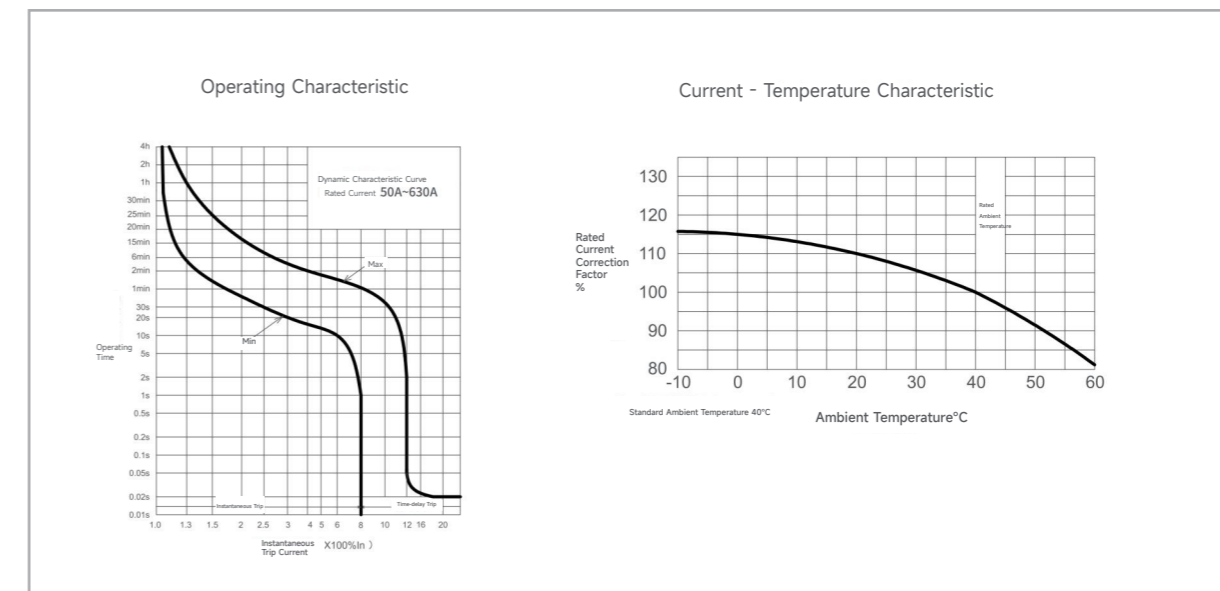

CQMGT/A.RT-800 Operating Characteristic Curve

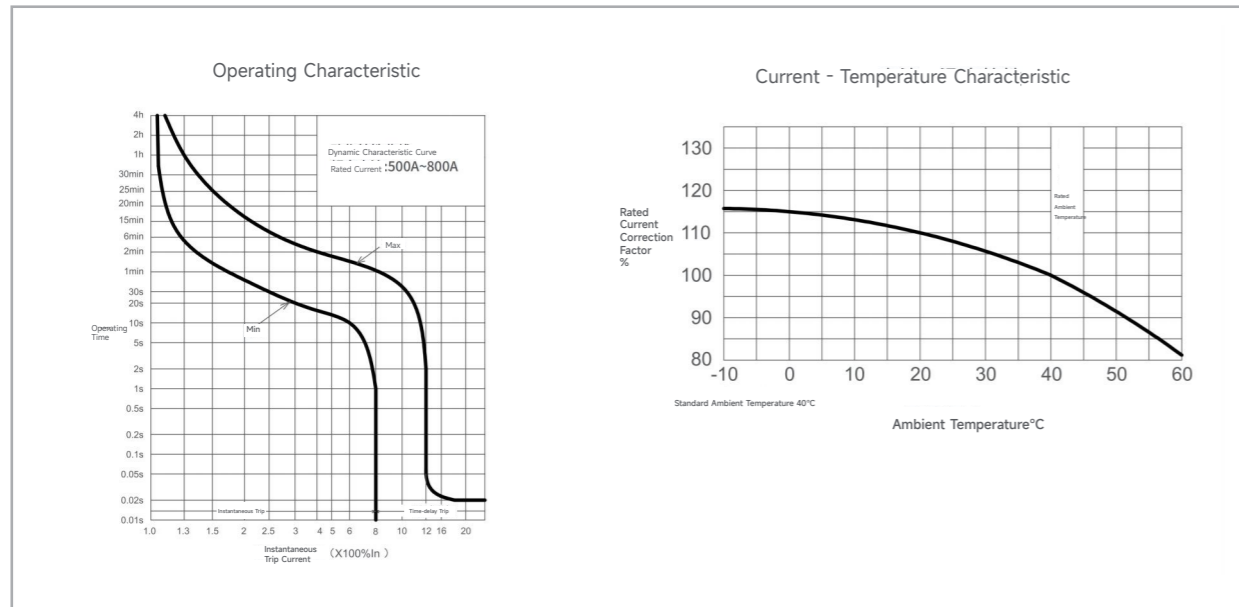

Outline and Installation Dimensions(mm)

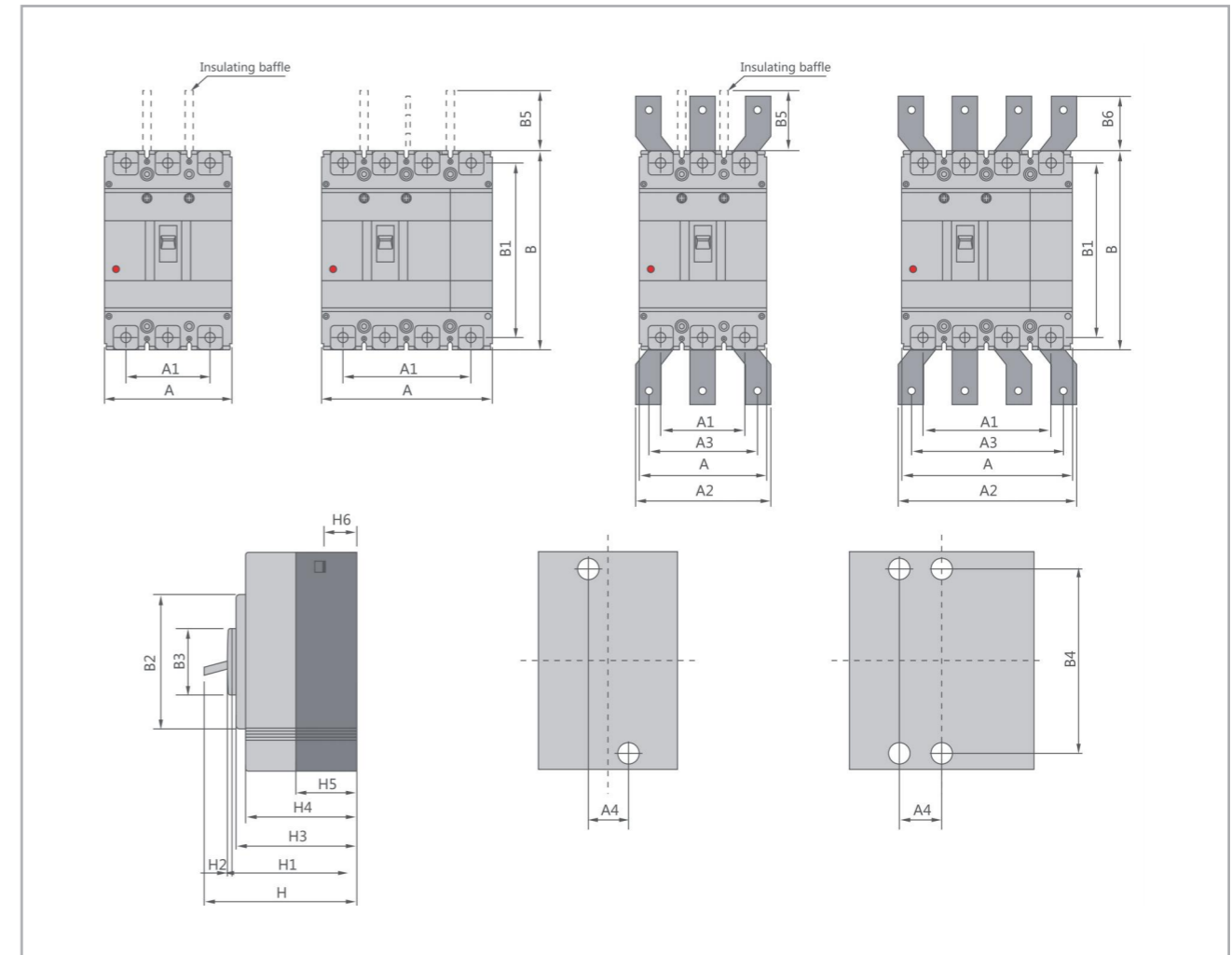

Molded case circuit breaker	Overall dimension																		Installation dimensions		Boit			
	A		A1		A2		A3		B	B1	B2	B3	B5	B6	H	H1	H2	H3	H4	H5		H6	A4	B4
	3P	4P	3P	4P	3P	4P	3P	4P																
CQM6T/A.RT-160CS	90	120	60	90	-	-	-	-	155	134	103	50	50	-	94	72	4	70	61	41	24	30	132	M8
CQM6T/A.RT-160M	90	120	60	90	-	-	-	-	155	134	103	50	50	-	109	83	4	83	76	24.5	24.5	30	132	M8
CQM6T/A.RT-250CS	105	140	70	105	-	-	-	-	165	144	103	50	100	-	96	72	4	70	61	46	24	35	126	M8
CQM6T/A.RT-250M	105	140	70	105	-	-	-	-	165	144	102	50	110	-	120	95	4	91	84	22.5	24	35	126	M8
CQM6T/A.RT-630SMH	140	185	88	132	140	196	112	168	257	230	179	90	110	42	155	107	5	105	97	64	35	44	194	M10
CQM6T/A.RT-800SMH	210	280	140	210	180	250	140	210	275	243	192	90	110	87	155	107	5	104	97	65	24	70	242.5	M12

CQM6E series

Electronic molded case circuit breaker



Product Features

- **Precise Electronic Trip:** Features an adjustable electronic release for highly accurate Long-Time, Short-Time, and Instantaneous (L-S-I) protection.
- **Advanced Ground Fault Protection:** Includes a dedicated ground fault (G) protection setting for enhanced system safety.
- **Visual Status Indication:** Equipped with an intuitive control panel featuring a current light bar and clear indicators for overload and pre-alarm status.
- **Communication Ready:** Provides the foundation for smart functionality, supporting integration with motorized operators for remote control.

Compliance

- Meets international and regional standards including

IEC/EN 60947-1(General Rules)	GB/T 14048.1
IEC/EN 60947-2(Circuit-Breakers)	GB/T 14048.2
IEC/EN 60947-3(Switchgear)	GB/T 14048.3
IEC/EN 60947-4(Contactors & Motor-Starters)	GB/T 14048.4

Selection Guide

CQM6 **E** - **160** **P/3** **400** **160A** **2** **A**

Product code	Shell frame grade	Shell frame rating current optional designator	Breaking capacity			
CQM6	E	160		S	M	H
Molded case circuit breaker	E Electronically Adjustable	160	160	/	50/35	50/50
		250	250	/	50/35	50/50
		630	630	35/25	50/35	75/75
		800	800	35/25	50/35	75/75
		1250	1250	35/25	50/35	75/75

Operating method	Number of poles	Decoupler method and internal accessories
P:Motorized operation Z:Turn the handle W:Direct operation	4 3-pole 4-pole	300 2: Intelligent disconnectors Note:The last two digits are the accessory code (see attachment)

Function	Four-pole products can be selected code
2	A

1:For power distribution
2:For motor protection



A:N-pole without protection,can not be combined
B:N-pole without protection,can be combined
C:N-pole with protection,can be combined
D:N-pole with protection,can not be combined
Note:If the customer does not have a clear request,four-pole products will be defaulted to the B category

Accessory List

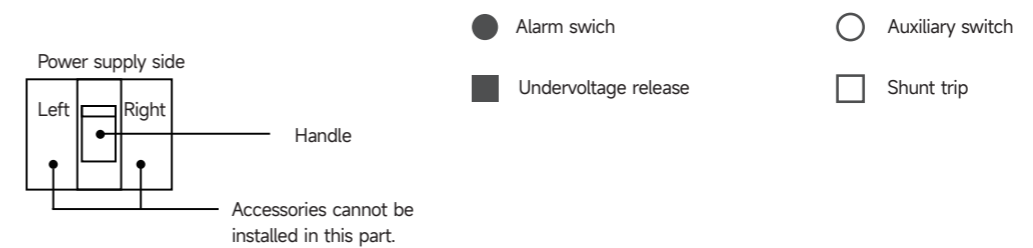
Model number	CQM6E-160	CQM6E-250	CQM6E-630	CQM6E-800	CQM6E-1250
Breaking capacity	M,H	M,H	S,M,H	S,M,H	S,M,H
Number of poles	3,4	3,4	3,4	3,4	3,4
Accessory code					
308	Alarm Switch				
310	Shunt Release				
320	Auxiliary Switch				
330	Undervoltage Release				
340	Shunt Release and Auxiliary Switch				
360	Two Auxiliary Switches				
370	Auxiliary Switch and Undervoltage Release				
318	Shunt Release and Alarm Switch				
328	Auxiliary Switch and Alarm Switch				
338	Undervoltage Release and Alarm Switch				
348	Shunt Release, Auxiliary Switch and Alarm Switch				
368	Two Auxiliary Switches and Alarm Switch				
378	Auxiliary Switch, Undervoltage Release and Alarm Switch				
380	Two Auxiliary Switches and Shunt Release				



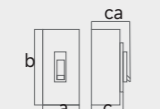

Main Technical Parameters

Model number		CQM6E-160		CQM6E-250	
Rated current of frame level Inm(A)		160		250	
Number of poles		3,4		3,4	
Rated current In(A),at 40°C,50°C,55°C		32, 63, 125, 160		160,250	
Rated operating voltage Ue(V),AC 50/60Hz		400/415		400/415	
Rated insulation voltage Ui (V)		800		800	
Rated impulse withstand voltage Uimp(KV)		8		8	
Breaking capacity designation		M	H	M	H
Short-circuit breaking capacity Icu/Ics(kA)		AC400/415V 50/35 50/50		50/35 50/50	
Rated short-time withstand current Icw(kA),1s		AC400/415V 2 2		5 5	
Selectivity category		B	B	B	B
Number of operating cycles (cycle)	ON	6000		6000	
	OFF	10000		10000	
Electronic decouping (adjustable)	Power distribution protection	●	●	●	●
	Motor protection	●	●	●	●
Accessory	Auxiliary contacts	●	●	●	●
	Alarm contacts	●	●	●	●
	Shunt disconnect	●	●	●	●
	Undervoltage detent	●	●	●	●
	Manual operating mechanism	●	●	●	●
	Motorized operating mechanism	●	●	●	●
	Backplane wiring	●	●	●	●
	Inserted	●	●	●	●
	Coupling plate	●	●	●	●
	Partition between phases	●	●	●	●
Overall dimensions (mm) (a-b-c-ca)	 3 P	90-155-84-109		105-165-93-120	
	 4 P	120-155-84-109		140-165-93-120	

Note: ● for optional accessories; "-" for no optional accessories.

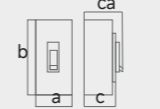
Main Technical Parameters

Model number		CQM6E-630			CQM6E-800			CQM6E-1250		
Rated current of frame level Inm(A)		630			800			1250		
Number of poles		3,4			3,4			3,4		
Rated current In(A),at 40°C,50°C,55°C		400, 630			630, 800			1000, 1250		
Rated operating voltage Ue(V),AC 50/60Hz		400/415			400/415			400/415		
Rated insulation voltage Ui (V)		800			800			800		
Rated impulse withstand voltage Uimp(KV)		8			8			8		
Breaking capacity designation		S	M	H	S	M	H	S	M	H
Short-circuit breaking capacity Icu/Ics(kA)		AC400/415V 35/25 50/35 75/75			35/25 50/35 75/75			35/25 50/35 75/75		
Rated short-time withstand current Icw(kA),1s		AC400/415V 8 8 8			10 10 10			19.2 19.2 19.2		
Selectivity category		B	B	B	B	B	B	B	B	B
Number of operating cycles (cycle)	ON	3000			3000			1000		
	OFF	8000			8000			3000		
Electronic decouping (adjustable)	Power distribution protection	●	●	●	●	●	●	●	●	●
	Motor protection	●	●	●	●	●	●	●	●	●
Accessory	Auxiliary contacts	●	●	●	●	●	●	●	●	●
	Alarm contacts	●	●	●	●	●	●	●	●	●
	Shunt disconnect	●	●	●	●	●	●	●	●	●
	Undervoltage detent	●	●	●	●	●	●	●	●	●
	Manual operating mechanism	●	●	●	●	●	●	●	●	●
	Motorized operating mechanism	●	●	●	●	●	●	●	●	●
	Backplane wiring	●	●	●	●	●	●	●	●	●
	Inserted	●	●	●	●	●	●	●	●	●
	Coupling plate	●	●	●	●	●	●	●	●	●
	Partition between phases	●	●	●	●	●	●	●	●	●
Overall dimensions (mm) (a-b-c-ca)	 3 P	140-257-105-155			210-275-105-155			210-275-105-155		
	 4 P	185-257-105-155			280-275-105-155			280-275-105-155		

Note: ● for optional accessories; "-" for no optional accessories.

Characteristic curve

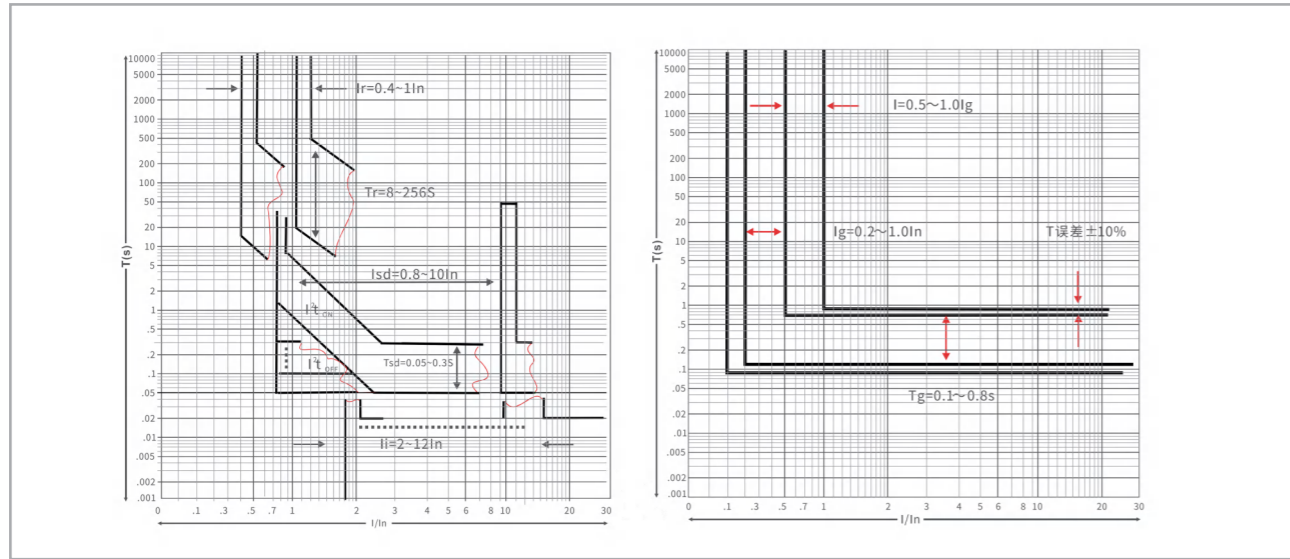

Intelligent Release Adjustment Panel

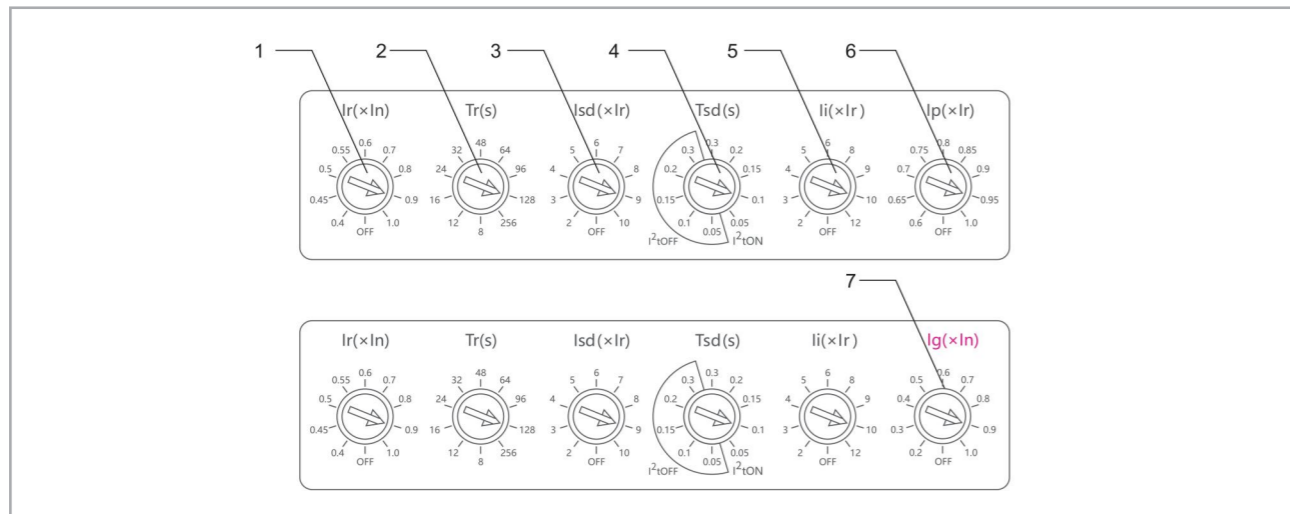

1. Ir: Rated Current (Ir) Setting Dial
The setting dial for the rated current, applicable to 160-1250 frame sizes. The selectable settings on the front panel are: 0.4, 0.45, 0.5, 0.55, 0.6, 0.7, 0.8, 0.9, 1.0, OFF.
2. Tr: Long-Time Delay (Tr) Setting Dial
The setting dial for the overload long-time delay. When the current passing through the circuit breaker reaches 1.5 times Ir (×Ir), the breaker trips within the set time. The selectable settings are: 8s, 12s, 16s, 24s, 32s, 48s, 64s, 96s, 128s, 192s, 256s.
3. Isd: Short-Time Delay Current (Isd) Setting Dial
The setting dial for the short-time delay current multiplier. Selectable settings are: 2, 3, 4, 5, 6, 7, 8, 9, 10, OFF. When a short-circuit current equal to the set value (×Ir, ×In) passes through the breaker, it will trip after a time delay.
4. Tsd: Short-Time Delay Operating Time (Tsd) Setting Dial
The setting dial for the short-time delay operating time. It is divided into inverse-time protection (t ON) and definite-time protection (t OFF). Selectable settings are: 0.05s, 0.1s, 0.15s, 0.2s, 0.3s. When a short-circuit current equal to Isd passes through the breaker, it will trip within the set time.
5. Ii: Instantaneous Current (Ii) Setting Dial
The setting dial for the instantaneous current multiplier. Selectable settings are: 2, 3, 4, 5, 6, 8, 9, 10, 12. When a short-circuit current equal to the set value (×In) passes through the breaker, it will trip instantaneously.
6. Ip: Pre-alarm Current (Ip) Setting Dial
The setting dial for the pre-alarm current multiplier. Selectable settings are: 60%, 65%, 70%, 75%, 80%, 85%, 90%, 95%, 100%, OFF. When the current passing through the breaker reaches the set value (×Ir, ×In), the pre-alarm indicator light will illuminate.
7. Ig: Ground Fault Current (Ig) Setting Dial
The setting dial for the ground fault current multiplier. Selectable settings are: 0.2, 0.3, 0.4, 0.5, 0.6, 0.7, 0.8, 0.9, 1.0, OFF. When the ground fault current passing through the breaker reaches the set value (×In), the breaker will trip due to the ground fault.

Characteristics of Intelligent Release: It has protection functions such as overload long-delay inverse time, short-circuit short-delay inverse time, short-circuit short-delay fixed time, and short-circuit instantaneous action. These functions can be set by the user to form the required protection characteristics. The inverse time action characteristics of long-delay overcurrent protection are shown in the table:

Current	time of action	
power distribution	1.05Ir	>2h inoperative(In>63A),1h inoperative (In≤63A)
	1.3r	<1h action
	1.51r	Setting time tr(s) Inm-125A、250A、400A、630A、800A、1250A 8、12、16、24、32、48、64、96、128、256

Remarks:Tolerance of operation value is ±10%,tolerance of operation time is ±15%.
Short delay overcurrent protection action characteristics

When Tsd is within the tON stall range,it is a fixed time limit:

Current	time of action					
Isd≤6lr counter-time limit	T ² T2=(6Xlr) ² Tsd					
I≥Isd and I≥6lr	Consolidation time	0.05	0.1	0.15	0.2	0.3
Inverse time limit to fixed time limit	Inaccuracies	±0.02	±0.03	±0.04	±0.06	±0.08
	Returnable time	-	-	0.14	0.21	0.3

Remarks :I is the actual passing current,T2 is the actual action time,Isd is the set short delay curent,Tsd is the set short delay action time

When Tsd is in the range of tOFF gear,it is fixed time limit:

Current	time of action					
I≥Isd Current Error±10%	Consolidation time	0.05	0.1	0.15	0.2	0.3
	Inaccuracies	±0.02	±0.03	±0.04	±0.06	±0.08
	Returnable time	-	-	0.14	0.21	0.3

Remarks:Iis the actual passing current,T2 is the actual action time;Isd is the short delay curent,Tsd is the short delay actiontime.

Short-circuit transient protection action characteristics

Current	Ii=(2,3,4,5,6,8,9,10,12)×In	
Motion Characteristics	Operating current	Minimum operating current 0.9Ii Maximum inoperative current 1.1Ii
	time of action	<0.1s

Grounding protection operating characteristics

Current	Ig=(0.2,0.3,0.4,0.5,0.6,0.7,0.8,0.9,1.0)×In	
Motion Characteristics	Ig≤0.9Ig Circuit breaker inoperative	Ig>1.1Ig
	time of action	Tg=0.4(fixed time limit)

The electronic striker panel indicators are set as follows



Overload pre-warning characteristics:

Load Current	$I < 1I_p$	$I \geq 1I_p$
Indicator status	Indicator light is not flashing, does not light up	Indicator light constant

Load Current	$I < 1.15I_p$	$I \geq 1.15I_p$
Indicator status	Indicator light is not on	Indicator light is on

Load Current	$\geq 0.4I_n$ (Single phase)	$1 \geq 0.2I_n$ (Tri-phase)
Indicator status	Indicator light is on	Indicator light is on

Note: 1. The above current error $\pm 10\%$.
 2. The pre-alarm current needs to satisfy the startup current constraint, i.e., the current cannot be lower than the operating condition.

Outline and Installation Dimensions(mm)

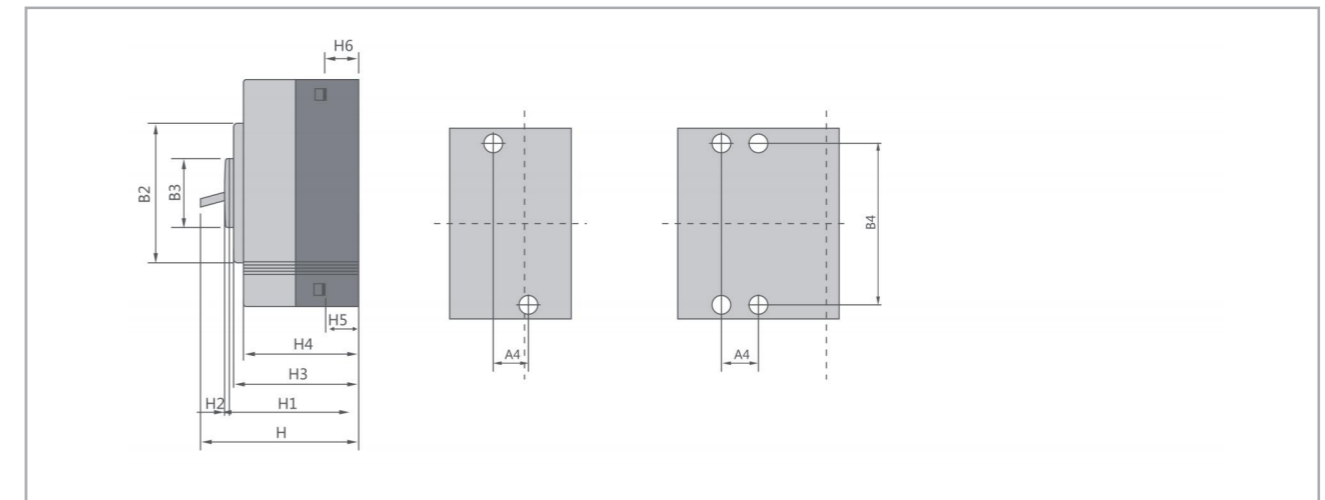
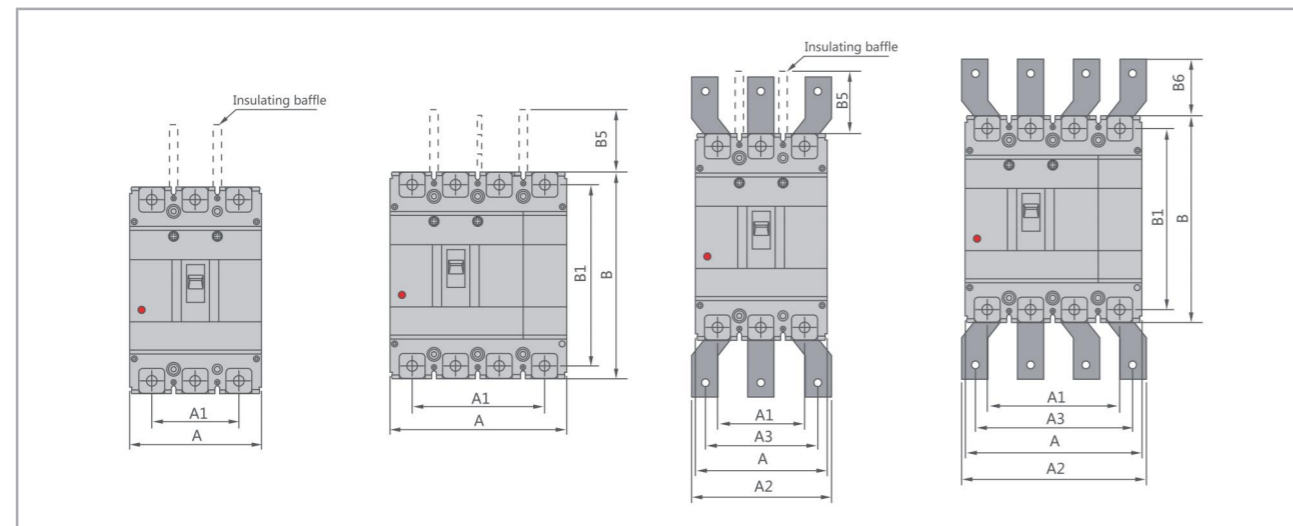

Molded case circuit breaker	Overall dimension																Installation dimensions		Boit					
	A		A1		A2		A3		B	B1	B2	B3	B5	B6	H	H1	H2	H3		H4	H5	H6	A4	B4
	3P	4P	3P	4P	3P	4P	3P	4P																
CQM6E-160	90	120	60	90	-	-	-	-	155	134	102	50	50	-	109	83	4	83	76	24.5	24.5	30	132	M8
CQM6E-250	105	140	70	105	-	-	-	-	165	144	102	50	110	-	120	95	4	91	84	22.5	24	35	126	M8
CQM6E-630	140	185	88	132	140	196	112	196	257	230	179	90	110	42	155	107	5	105	97	30	32	44	194	M10
CQM6E-800	210	280	140	210	180	250	140	250	275	243	192	90	110	87	155	107	5	104	97	25	25	70	242.5	M12
CQM6E-1250	210	280	140	210	180	250	140	250	275	243	192	90	110	87	155	107	5	104	97	25	25	70	242.5	M10*2

Appearance and installation dimensions at the rear of the panel

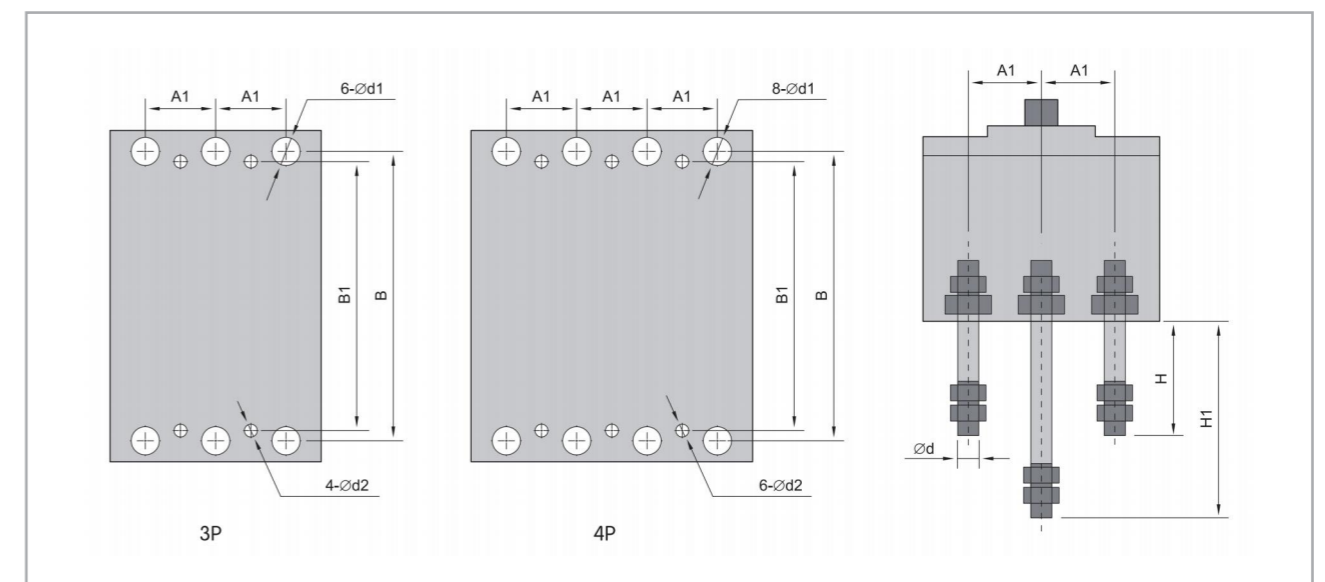

Appearance and installation dimensions of the rear part for the plug-in type(on the panel)

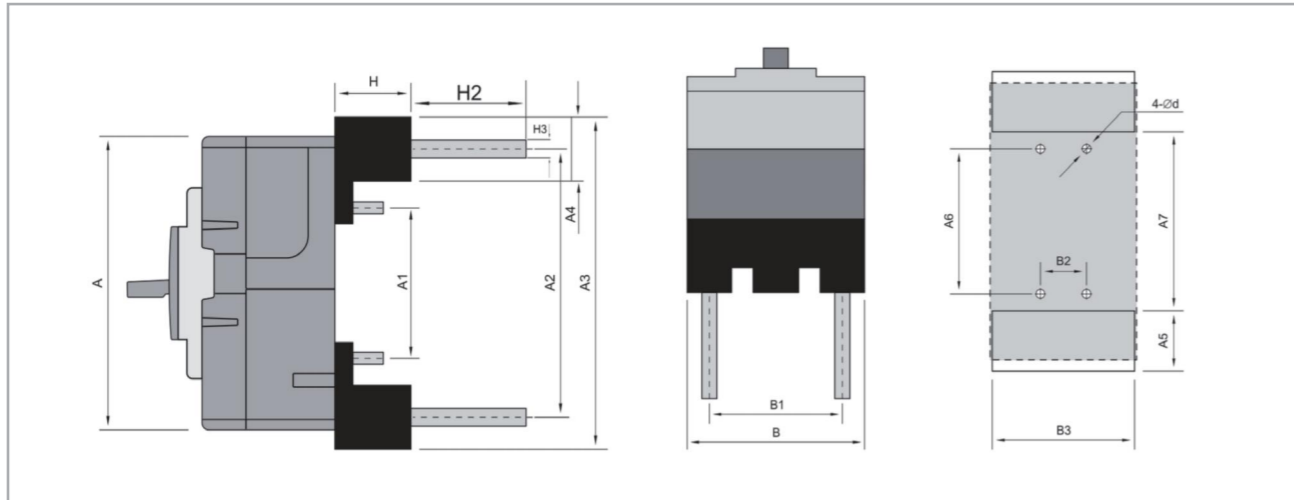

Molded case circuit breaker	B-board rear wiring dimensions										C Front-of-Board Wiring Dimensions				C Plug-in wiring size												
	A1	B	B1	H	H1	φd	φd1	φd2	φd3	A4	B4	A	A1	A2	A3	A4	A5	A6	A7	H	B	B1	B2	B3	φd	H2	H3
125	25	114	111	62	87	6	14	5	5	25	111	130	58	115	132	17.5	20	58	97	28	75	50	50	77	5.5	15	10.5
160	30	134	132	72	112	8	18	5	5	30	132	155	60	134	173	38	40	60	98	50	92	60	60	94	6.5	31	19.5
250	35	144	126	87	126	12	24	5	5	35	126	165	54	144	184	45	47	54	95	50	107	70	70	109	6.5	35	21.5
630	44	230	194	83	136	18	35	7	7	44	194	257	125	225	280	55	57	125	169	60	140	87	60	142	9	32	φ23
800	70	243	243	174	243	26	48	7	7	70	243	275	147	242	42	55	58	147	190	91	218	140	107	222	10.5	31	φ27

Appearance and installation dimensions of the rear part for the plug-in type(on the panel)

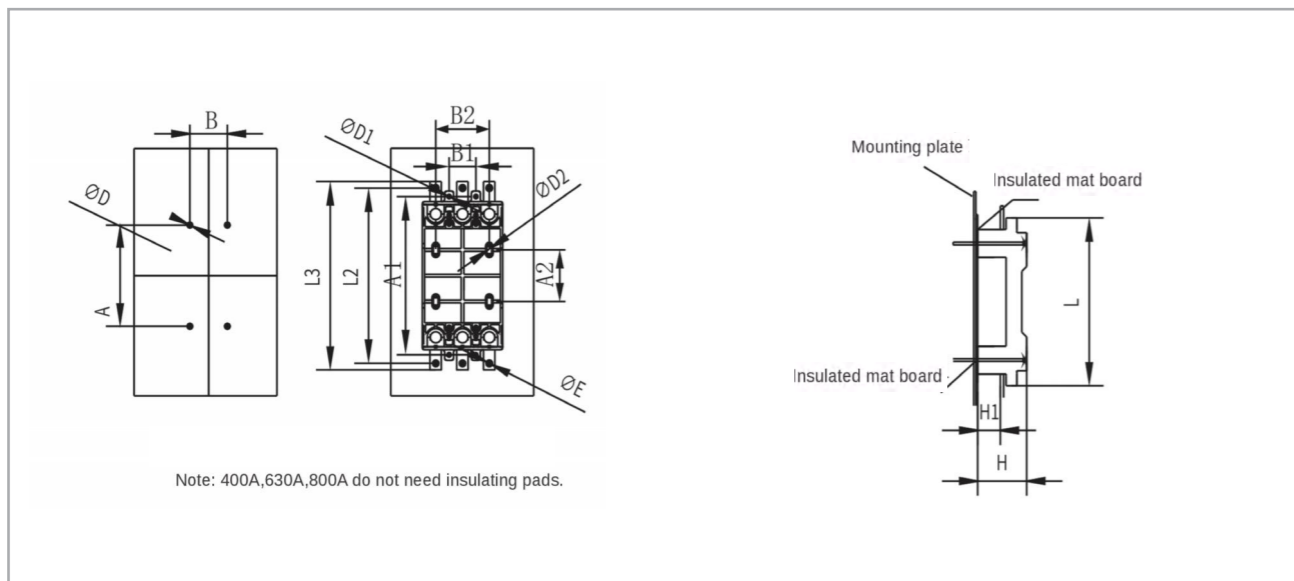

Model Number	A	E	L2	L3	D	E	H	H1	L	A1	B1	D1	A2	B2	D2
160	112	30	200	216	4.5	6.5	56	28	182	172	30	5.5	67	60	6.5
250	150	35	233	245	4.5	8.5	74	33	202	191	35	5.5	74	70	6.5
630	283	70	363	405	6.5	12.5	125	67	341	327	70	6.5	143	140	7
800	283	70	363	405	6.5	12.5	125	67	341	327	70	6.5	143	140	7

The internal accessories of CQM6E series include under-voltage detent,shunt detent,auxiliary alarm detent,its main technical parameters and wiring diagrams are as follows.

Under-voltage release device

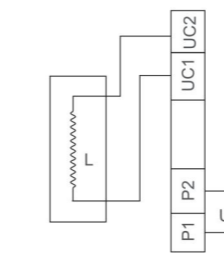

Internal accessories	Main Performance
Rated voltage of the power supply	
AC220,AC240 AC380,AC415	A. When the supply voltage drops to 70%and 35%of the rated voltage, the undervoltage detector shall operate. B. When the electro-hydraulic voltage is lower than 35%of the rated voltage,the undervoltage detractor should not be able to absorb,in order to prevent the circuit breaker from closing. C.When the power supply voltage is equal to or greater than 85%of the rated voltage,the undervoltage detractor will ensure the absorption, and ensure the reliable closing of the circuit breaker.

Shunt release device

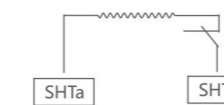

Rated supply voltage	Main Performance
DC24,DC110 AC220,AC380	The shunt release can operate reliably between 70%and 110%of the rated voltage value.

Auxiliary alarm contact



Rated voltage of power supply	Main performance
Auxiliary switch AC 125V 5A,AC 250V 3A DC 125V 0.4A,DC 125V 0.2A	Provides differentiated signals for circuit breakers in the "closed" and "open"positions.



Alarm switch AC 125V 5A,AC 250V 3A DC 125V0.4A,DC 125V 0.2A	Provides signals to distinguish between "normal operation" and "fault free release" positions of circuit breakers.
---	--



Auxiliary alarm switch AC 125V 5A,AC 250V 3A DC 125V 0.4A,DC125V 0.2A	Provides signals to distinguish between "closed", "open" and "fault free release" positions of the circuit breaker.
---	---

Internal accessory

DC3 Electric Operation Mechanism
DC3 series electric operation mechanism is adopted advanced switching power supply technology,utilizing smallpermanent contact motordrive,small working current,suitable for 63-800A plastic case circuit breakers.

Model Number	DC3-125	DC3-160	DC3-250	DC3-630	DC3-800	
Compatible Model	CQM6-125	CQM6-160 CQM6RT-160 CQM6RE-160	CQM6RE-250 CQM6-250 CQM6L-250 CQM6RT-250 CQM6Z-250	CQM6-630 CQM6L-630 CQM6RT-630 CQM6RE-630 CQM6Z-630	CQM6-800 CQM6L-800 CQM6RT-800 CQM6RE-800 CQM6L-1250 CQM6RE-1250	
Overall Dimensions	A	25	30	35	44	70
	B	117	132	126	194	243
	C	73	90	90	130	130
	H	98	98(89.5)	102(92)	152	153
Rated voltated V	AC-110-240, DC100-220,DC24			AC 230,DC 220 AC 100,DC 110		
Starting current A	≤0.5			≤2		
Mechanical life(times)	14000			10000	5000	
Power(W)	14			35		

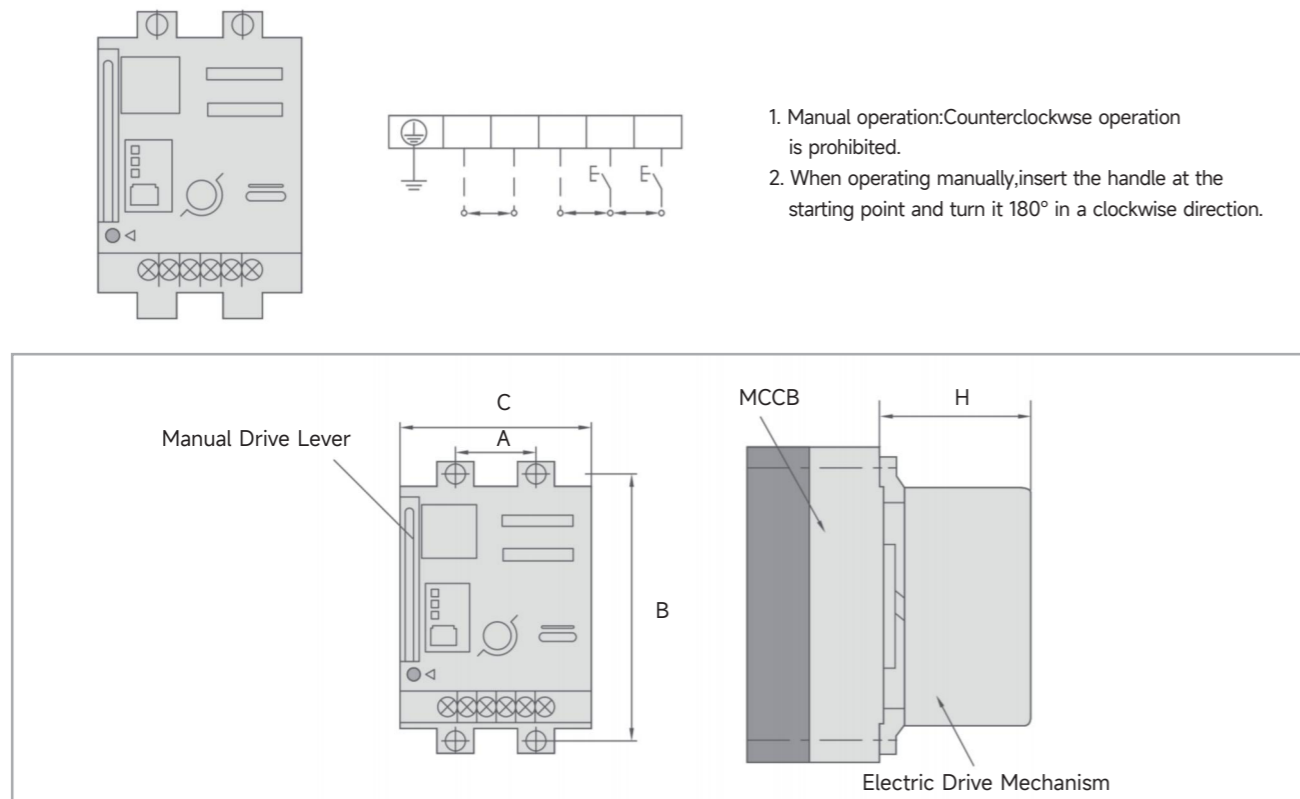

Manual operating mechanism

Shape of the circular handle and the door panel opening size (the distance from the center of the opening to the hinge should not be less than 200mm)

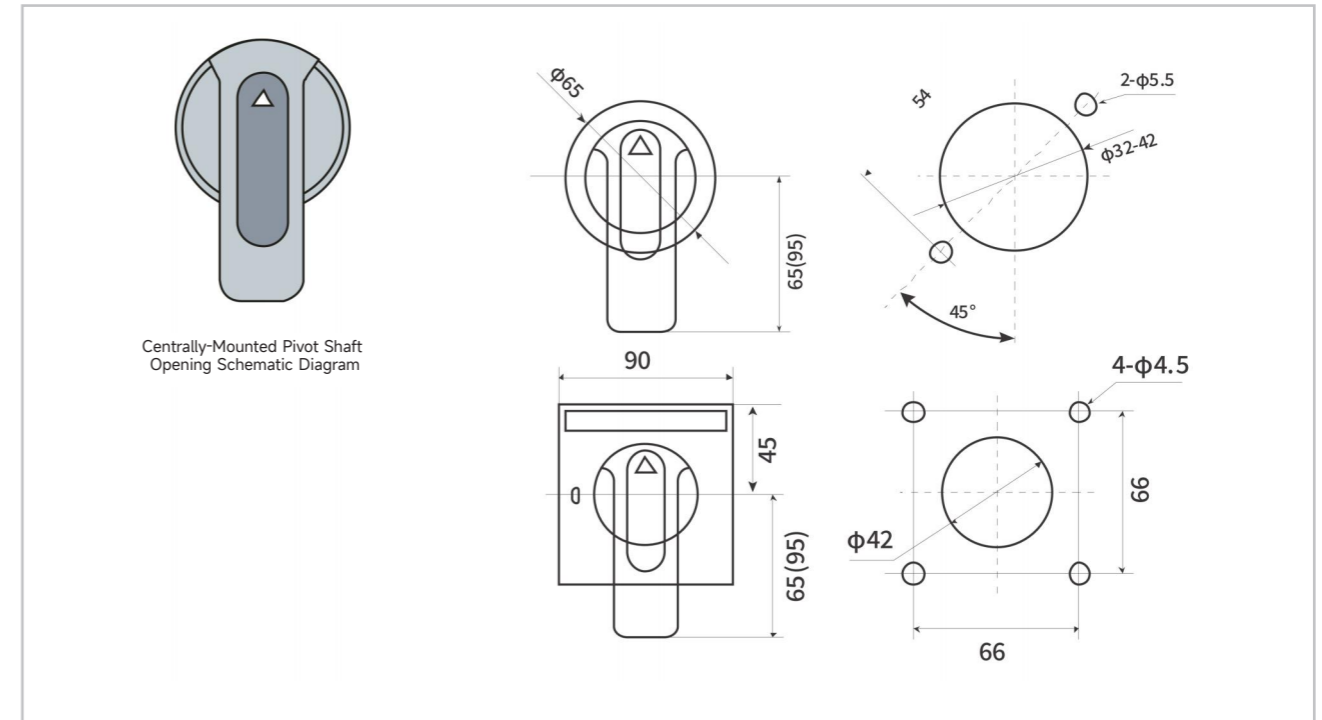

Outline and Installation Schematic Diagram of the Central Series Manual Operation Mechanism

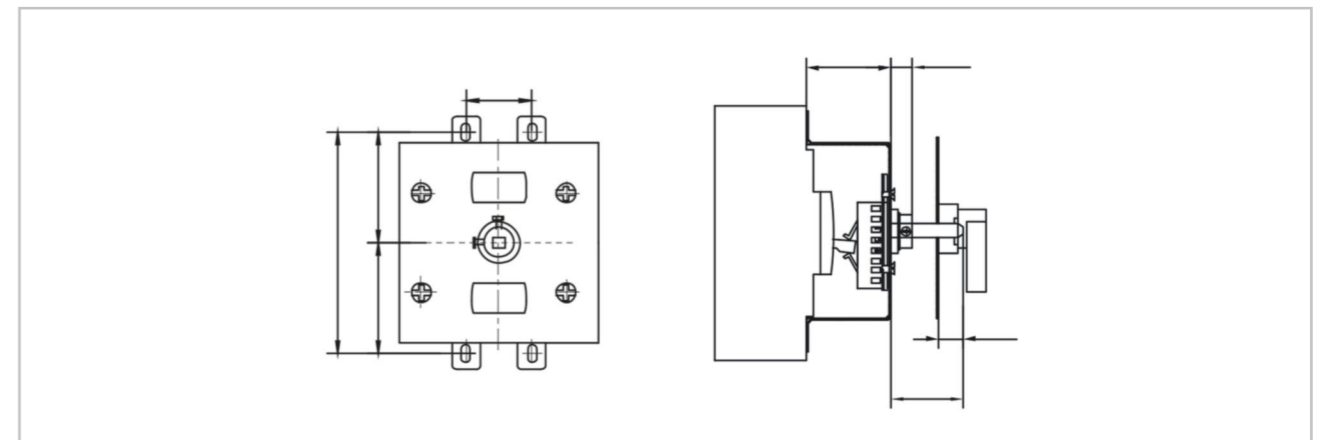

Hand-operated mechanism model	A	B	C	D	H
160	30	132	66	66	46
250	35	126	63	63	51
630	128	194	97	97	76
800	198	243	121.5	121.5	76
1250	198	243	121.5	121.5	76

CQM7DC Series

Molded Case Circuit Breaker



Product Features

- Zero Arc Chute Design**
 Features advanced arc extinguishing technology to effectively eliminate arcing hazards during disconnection, ensuring operational safety.
- High Temperature Resistance**
 Operates reliably in ambient temperatures up to +50°C without performance degradation, suitable for demanding environments.
- Wide Current Range**
 Available in multiple current ratings from 63A to 1600A to meet various application requirements in solar, EV charging, and energy storage systems.
- UL489 Compliance**
 Meets UL489 standard requirements, ensuring compliance with North American safety regulations and global market acceptance.

Type designation

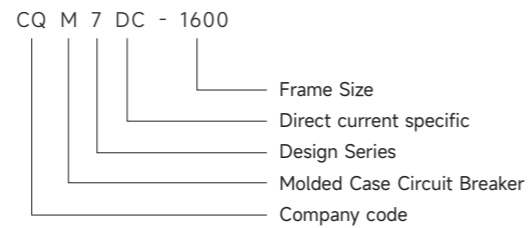

Technical Specifications

Parameter	CQM7DC-320	CQM7DC-630	CQM7DC-1600
Rated Current (A)	63, 80, 100, 125, 140, 160, 180, 200, 225, 250, 315, 320	225, 250, 320, 350, 400, 500, 630	800, 1000, 1250, 1500, 1600
Number of Poles	2P	2P	3P,4P
Rated Operational Voltage Ue DC (V)	1500	1500	1500
Rated Insulation Voltage Ui (V)	1800	1800	1800
Rated Impulse Withstand Voltage Uimp (kV)	12	12	12
Power Frequency Withstand Voltage (1 min) (kV)	3.5	3.5	3.5
Rated Ultimate Short-Circuit Breaking Capacity Icu	DC1200V DC1500V	DC750V DC1000V	DC750V DC1000V DC1200V DC1500V
Rated Service Short-Circuit Breaking Capacity Ics (kA)	35kA 20kA	85kA 50kA	50kA 30kA 15kA 10kA
Mechanical Life (operations)	4000	4000	4000
Electrical Life (operations)	10000	10000	500
Arc Chute Distance (mm)	50 / 0	50 / 0	50 / 0
Dimensions W×L×H (mm)	90×215×136	110×275×152	3P: 210×340×244 4P: 280×340×244
Instantaneous Trip Setting	5In or 10In	5In or 10In	5In or 10In
Reference Ambient Temperature (°C)	50	50	50

Accessory List

Model number	CQM7DC-320	CQM7DC-630	CQM7DC-1600	
Number of poles	2P	2P	3P	4P
Accessory code	Accessory name			
0	None			
8	Alarm Contact			
10	Shunt Release			
18	Shunt Release + Alarm Contact			
20	Auxiliary Contact (1NO)			
27	Auxiliary Contact (2NO)			
28	Auxiliary Contact (1NO) + Alarm Contact			
29	Auxiliary Contact (2NO) + Alarm Contact			
30	Undervoltage Release			
38	Undervoltage Release + Alarm Contact			
40	Shunt Release + Auxiliary Contact (1NO)			
48	Shunt Release + Auxiliary Alarm Contact			
62	Two Sets of Auxiliary Contacts (2NO each)			
68	Auxiliary Contact (1NO) + Auxiliary Alarm Contact			
69	Auxiliary Contact (2NO) + Auxiliary Alarm Contact			
70	Undervoltage Release + Auxiliary Contact (1NO)			



Note: Code 50: For models 125 and 160, a custom left-side undervoltage release is required. For model 250, a custom left-side shunt release is required. Optional voltage ranges for shunt/undervoltage releases: DC24V, DC110V, DC220V, AC230V, AC400V. Standard production voltage: AC230V.

CQW2 Series

Air Circuit Breaker



Product Features

- Rated current from 200A to 6300A, suitable for AC 400V/690V, 50Hz distribution networks.
- Provides comprehensive protection: overload, short-circuit, undervoltage, and earth fault protection, with isolation functionality.
- High breaking capacity (Icu up to 120kA at AC415V) and short-circuit withstand capability.
- Modular and compact design supports both fixed and withdrawable installation.
- Intelligent controller options (L/M/H-type) with precise selective protection, communication support (e.g., Profibus-DP), and remote monitoring capabilities.
- Complies with IEC 60947-2 and GB/T 14048 standards.

Operating & Installation Conditions

- Ambient temperature: -5°C to +40°C (average ≤ +35°C within 24 hours).
- Altitude: ≤ 2000 m (derating required above 2000 m).
- Pollution degree: 3.
- Relative humidity: ≤ 50% at +40°C; higher humidity permissible at lower temperatures.
- Suitable for installation in non-explosive environments, free of conductive dust and corrosive substances.
- Must be mounted vertically (±5° tilt tolerance).
- Protection rating: IP30 (IP40 with door frame mounted).
- Installation category:
 - Main circuit & undervoltage release: IV
 - Auxiliary/control circuits: III
- Connection: Horizontal or vertical, based on model configuration.

Type designation



Code Position	Code Symbol	Meaning & Explanation
①	Enterprise Code	Zhejiang Chuangqi Electric Co., LTD.
②	Product Code	Universal Circuit Breaker
③	Design Serial Number	Design Serial Number
④	Frame Rating Code	1600, 2000, 3200, 4000, 6300
⑤	Number of Poles	3: 3-Pole, 4: 4-Pole
⑥	Mounting Type	D: Drawout Type, F: Fixed Type
⑦	Rated Current	200~6300A
⑧	Intelligent Controller	L: Electronic Type, M: Standard Type, H: Communication Type
⑨	Control Circuit Voltage	AC230V, AC400V, DC220V, DC110V

Technical Specifications

Parameter	CQW2-1600	CQW2-2000	CQW2-3200	
Rated Current In (A)	200, 400, 630, 800 1000, 1250, 1600	400, 630, 800, 1000 1250, 1600, 2000	2000, 2500, 2900, 3200	
N-pole Rated Current	100%In	100%In	100%In	
Rated Operational Voltage Ue	AC415V/690V	AC415V/690V	AC415V/690V	
Rated Frequency f	50/60Hz	50/60Hz	50/60Hz	
Rated Insulation Voltage Ui	1000V	1250V	1000V	
Rated Impulse Withstand Voltage Uimp	12kV	12kV	12kV	
Number of Poles	3, 4	3, 4	3, 4	
Total Break Time	≤30ms	≤30ms	≤30ms	
Closing Time	≤70ms	≤70ms	≤70ms	
Rated Ultimate Short-Circuit Breaking Capacity Icu (RMS)	AC415V	65kA	80kA	
	AC690V	42kA	65kA	
Rated Service Short-Circuit Breaking Capacity Ics (RMS)	AC415V	55kA	80kA	
	AC690V	35kA	65kA	
Rated Making Capacity Icm (Peak)	AC415V	143kA	176kA	
	AC690V	88kA	143kA	
Rated Short-Time Withstand Current Icw (RMS)	AC415V	42kA	60kA	
	AC690V	35kA	40kA	
Operating Performance (Number of operations)	Mechanical Life - Maintenance-Free	10000	15000	15000
	Mechanical Life - With Maintenance	10000	15000	15000
	Operating Frequency	20 operations/hour	20 operations/hour	20 operations/hour
	Electrical Life - AC415V	15000	15000	15000
	Electrical Life - AC690V	30000	30000	30000
	Operating Frequency	60 operations/hour	60 operations/hour	60 operations/hour
Control and Protection Unit	L Type (Electronic Type)			
	M Type (Standard Type)			
	H Type (Communication Type)			
Connection Method	Horizontal			
	Vertical			
Standard	IEC60947-2, GB/T14048.2			



Technical Specifications

Parameter	CQW2-4000	CQW2-6300
Rated Current In (A)	3200、3600、4000	4000、5000、6300
N-pole Rated Current	100%In	100%In
Rated Operational Voltage Ue	AC415V/690V	AC415V/690V
Rated Frequency f	50/60Hz	50/60Hz
Rated Insulation Voltage Ui	1000V	1000V
Rated Impulse Withstand Voltage Uimp	12kV	12kV
Number of Poles	3、4	3、4
Total Break Time	≤30ms	≤30ms
Closing Time	≤70ms	≤70ms
Rated Ultimate Short-Circuit Breaking Capacity Icu (RMS)	AC415V	100kA
	AC690V	80kA
Rated Service Short-Circuit Breaking Capacity Ics (RMS)	AC415V	85kA
	AC690V	70kA
Rated Making Capacity Icm (Peak)	AC415V	220kA
	AC690V	176kA
Rated Short-Time Withstand Current Icw (RMS)	AC415V	85kA
	AC690V	70kA
Operating Performance (Number of operations)	Mechanical Life - Maintenance-Free	6000
	Mechanical Life - With Maintenance	3000
	Operating Frequency	20 operations/hour
	Electrical Life - AC415V	12500
	Electrical Life - AC690V	25000
Control and Protection Unit	Operating Frequency	60 operations/hour
	L Type (Electronic Type)	
	M Type (Standard Type)	
Connection Method	H Type (Communication Type)	
	Horizontal	
Standard	Vertical	
	IEC60947-2、GB/T14048.2	

Accessory List

Accessory Name	Parameters	
Standard Configuration	Closing Solenoid	AC230V, AC400V, DC220V, DC110V
	Shunt Release	AC230V, AC400V, DC220V, DC110V
	Energy Storage Motor	AC230V, AC400V, DC220V, DC110V
	Auxiliary Switch	4 changeover contacts (default), 5 changeover contacts, 4NO+4NC, 6NO+6NC
	Others	Phase barrier, Door frame, Drawer base three-position lock
Optional Configuration	Undervoltage Release	AC230V, AC400V Instantaneous, Delayed: 0.5s, 1s, 3s, 5s
	Trip Locking Device	1 lock + 1 key, 2 locks + 1 key, 3 locks + 2 keys, 6NO+6NC
	Mechanical Interlock	For 2 circuit breakers: Linkage interlock (vertical), Cable interlock
		For 3 circuit breakers: Linkage interlock (vertical), Cable interlock
	Others	Residual Current Transformer, External Neutral Current Transformer, Relay Module Communication Module (Profibus-DP), Power Module, Wireless Remote Control Module

Intelligent Controller



Parameter	CQW2-L	CQW2-M	CQW2-2M
			
Basic Functions	Overload long-time delay protection; Short-time delay short-circuit protection; Instantaneous short-circuit protection; Ground fault protection; Dial switch grading setting; Running current bar graph indication; Test function; Fault recording function; Thermal memory function	Overload long-time delay protection; Short-time delay short-circuit protection; Instantaneous short-circuit protection; Ground fault protection (differential type); LED digital display; Key setting method; Ammeter function; Test function; Fault recording function; Thermal memory function	Overload long-time delay protection; Short-time delay short-circuit protection; Instantaneous short-circuit protection; Ground fault protection (differential type); LED digital display; Key setting method; Ammeter function; Test function; Fault recording function; Thermal memory function; Clock function; Self-diagnosis function; Contact pattern and mechanical operation count
Optional Functions	MCR make-break and over-limit tripping; Contact output; 3P+N type neutral protection	MCR make-break and over-limit tripping; Contact output; Voltage function; Residual current type leakage protection; Clock function; Current unbalance protection; Remote reset function; Load monitoring function; 3P+N type neutral protection; Low voltage ride-through	MCR make-break and over-limit tripping; Contact output; Voltage function; Residual current type leakage protection; Current unbalance protection; Remote reset function; Load monitoring function; 3P+N type neutral protection; Low voltage ride-through
Optional Accessories	DC Power Module (DC110V/220V) External N-phase Transformer	DC Power Module (DC110V/220V) External N-phase Transformer Ground Current Transformer ZT100 Residual Current Transformer ZCT1 ST201 Relay Module ST-4 Power Module ST Handheld Programmer	DC Power Module (DC110V/220V) External N-phase Transformer Ground Current Transformer ZT100 Residual Current Transformer ZCT1 ST201 Relay Module ST-4 Power Module ST Handheld Programmer

Note: 1.Only one of the following functions can be selected: 3P+N neutral protection, ground current type leakage protection, or residual current leakage protection. The corresponding transformer accessory must be additionally selected.

2.Only one signal unit (S1, S2, or S3) can be selected.

3.For detailed instructions on the intelligent controller, please refer to the "SW1 Series Intelligent Controller User Manual".

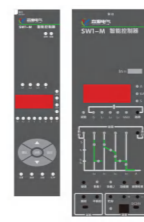
Intelligent Controller

Parameter	CQW2-2H	CQW2-3M	CQW2-3H
			
Basic Functions	Overload long-time delay protection; Short-circuit short-time delay protection; Short-circuit instantaneous protection; Ground fault protection (differential type); LED digital tube display; Key setting method; Ammeter function; Fault memory function; Thermal memory function; Clock function; Self-diagnosis function; Contact pattern and mechanical operation count; Communication function	Load monitoring (current method 1); Multi-curve long-time delay protection; Multi-curve short-time inverse-time protection; Short-time definite-time protection; Instantaneous protection; Current unbalance (phase loss) protection; Ground fault alarm; Ground fault protection (default T-type); Neutral protection; Four-phase current and ground current measurement; Thermal capacity; Eight records of faults, alarms and status changes; Historical current peak; Contact equivalent; Operation count; Clock function; Self-diagnosis; Chinese graphical LCD display; LCD status indicator; Keyboard operation	Load monitoring (current method 1); Multi-curve long-time delay protection; Multi-curve short-time inverse-time protection; Short-time definite-time protection; Instantaneous protection; Current unbalance (phase loss) protection; Ground fault alarm; Ground fault protection (default T-type); Neutral protection; Four-phase current and ground current measurement; Thermal capacity; Eight records of faults, alarms and status changes; Historical current peak; Contact equivalent; Operation count; Clock function; Self-diagnosis; Chinese graphical LCD display; LCD status indicator; Keyboard operation; Communication function
Optional Functions	MCR make-break and over-limit tripping; Contact output; Voltage function; Residual current type leakage protection; Clock function; Current unbalance protection; Remote reset function; Load monitoring function; 3P+N type neutral protection; Low voltage ride-through	Function Table: D, U, UD, P, PD, H Select HD from the table (refer to function table description) Signal Unit: S1, S2, S3 Load Monitoring: Current Method 2 3P+N Type Neutral Protection Ground Current Type Leakage Protection Residual Current Type Leakage Protection Remote Reset Function	Function Table: D, U, UD, P, PD, H Select HD from the table (refer to function table description) Signal Unit: S1, S2, S3 Load Monitoring: Current Method 2 3P+N Type Neutral Protection Ground Current Type Leakage Protection Residual Current Type Leakage Protection Remote Reset Function Profibus-DP Communication Protocol Device-net Communication Protocol
Optional Accessories	DC Power Module (DC110V/220V) External N-phase Transformer Ground Current Transformer ZT100 Residual Current Transformer ZCT1 ST201 Relay Module ST-4 Power Module ST Handheld Programme	DC Power Module (DC110V/220V) External N-phase Transformer Ground Current Transformer ZT100 Residual Current Transformer ZCT1 ST201 Relay Module Selective Zone Interlocking Protection Device	DC Power Module (DC110V/220V) External N-phase Transformer Ground Current Transformer ZT100 Residual Current Transformer ZCT1 ST201 Relay Module Selective Zone Interlocking Protection Device

D	U	UD	P
Demand Measurement (Current)	Voltage Measurement	Voltage Measurement	Voltage Measurement
Demand Protection	Frequency Measurement	Frequency Measurement	Frequency Measurement
	Voltage Unbalance Rate Measurement	Voltage Unbalance Rate Measurement	Voltage Unbalance Rate Measurement
	Phase Sequence Detection	Phase Sequence Detection	Phase Sequence Detection
	Overvoltage Protection	Current Demand Measurement	Power Measurement
	Undervoltage Protection	Overvoltage Protection	Power Factor Measurement
	Voltage Unbalance Protection	Undervoltage Protection	Energy Measurement
	Overfrequency Protection	Voltage Unbalance Protection	Overvoltage Protection
	Underfrequency Protection	Overfrequency Protection	Undervoltage Protection
	Phase Sequence Protection	Underfrequency Protection	Voltage Unbalance Protection
		Phase Sequence Protection	Overfrequency Protection
		Demand Protection	Underfrequency Protection
			Phase Sequence Protection

PD	H	HD
Voltage Measurement	Voltage Measurement	Voltage Measurement
Frequency Measurement	Frequency Measurement	Frequency Measurement
Voltage Unbalance Rate Measurement	Voltage Unbalance Rate Measurement	Voltage Unbalance Rate Measurement
Phase Sequence Detection	Phase Sequence Detection	Phase Sequence Detection
Power Measurement	Power Measurement	Power Measurement
Power Factor Measurement	Power Factor Measurement	Power Factor Measurement
Energy Measurement	Energy Measurement	Energy Measurement
Demand Measurement (Current, Power)	Harmonic Measurement	Demand Measurement (Current, Power)
Overvoltage Protection	Undervoltage Protection	Undervoltage Protection
Undervoltage Protection	Voltage Unbalance Protection	Overvoltage Protection
Voltage Unbalance Protection	Overfrequency Protection	Undervoltage Protection
Overfrequency Protection	Underfrequency Protection	Voltage Unbalance Protection
Underfrequency Protection	Phase Sequence Protection	Overfrequency Protection
Phase Sequence Protection		Underfrequency Protection
		Phase Sequence Protection
		Reverse Power Protection

Secondary Circuit Wiring Diagram

Wiring diagram of secondary circuit for SW1-1600-6300 circuit breakers equipped with L/M type intelligent controllers (auxiliary switch default configuration: 4 changeover contacts)

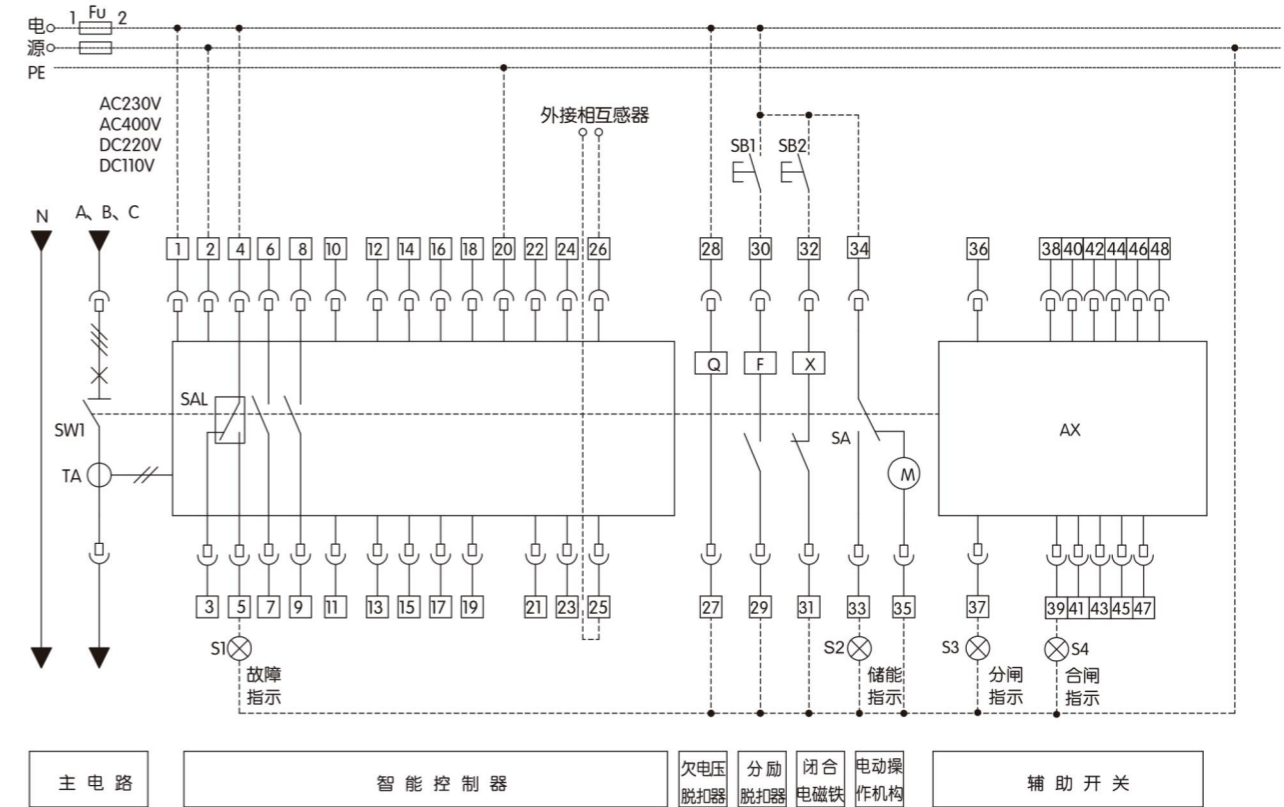

Terminal Number	Function Description	Symbol	Explanation	Remarks
1、2	Auxiliary power input: AC230V, AC400V, DC220V, DC110V	SW1	SW1 Universal Circuit Breaker	Customer self-provided
	For DC power: 1 is (+), 2 is (-)	S1-S4	Signal lamp	Customer self-provided
3、4、5	Fault trip auxiliary contact, contact capacity: AC250V, 3A	TA	Current transformer	
20	Grounding (PE)	SAL	Micro switch	Customer self-provided
27、28	Undervoltage release	SB1	Open button	Customer self-provided
29、30	Shunt release	SB2	Close button	
31、32	Closing electromagnet	x	Closing electromagnet	
33、34、35	Motor-operated mechanism (motor energy storage), 37connect green wire, 38 connect black wire, 39 connect red wire	F	Shunt release	
36-48	Auxiliary contact terminal	Q	Undervoltage release	
		M	Motor-operated mechanism	Customer self-provided
		SA	Travel switch of motor-operated mechanism	Customer self-provided
		Fu	Fuse	Customer self-provided
		PE	Grounding	
		N	Neutral line (N phase)	
		A, B, C	Phase line	
	For customer optional use of AX auxiliary switch form	AX	Auxiliary switch	

I: Four changeover contacts (default)

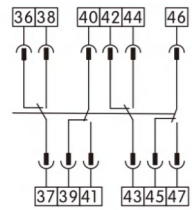

II: Six changeover contacts

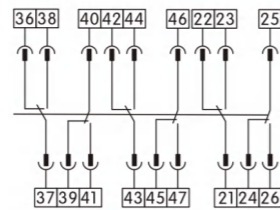

III: Three normally open and three normally closed contacts

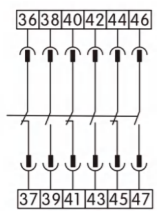

IV: Four normally open and four normally closed contacts

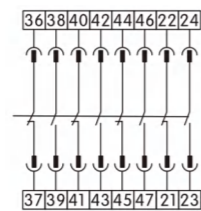

Wiring diagram of secondary circuit for SW1-1600-6300 circuit breakers equipped with H type intelligent controllers (auxiliary switch default configuration: 4 changeover contacts)

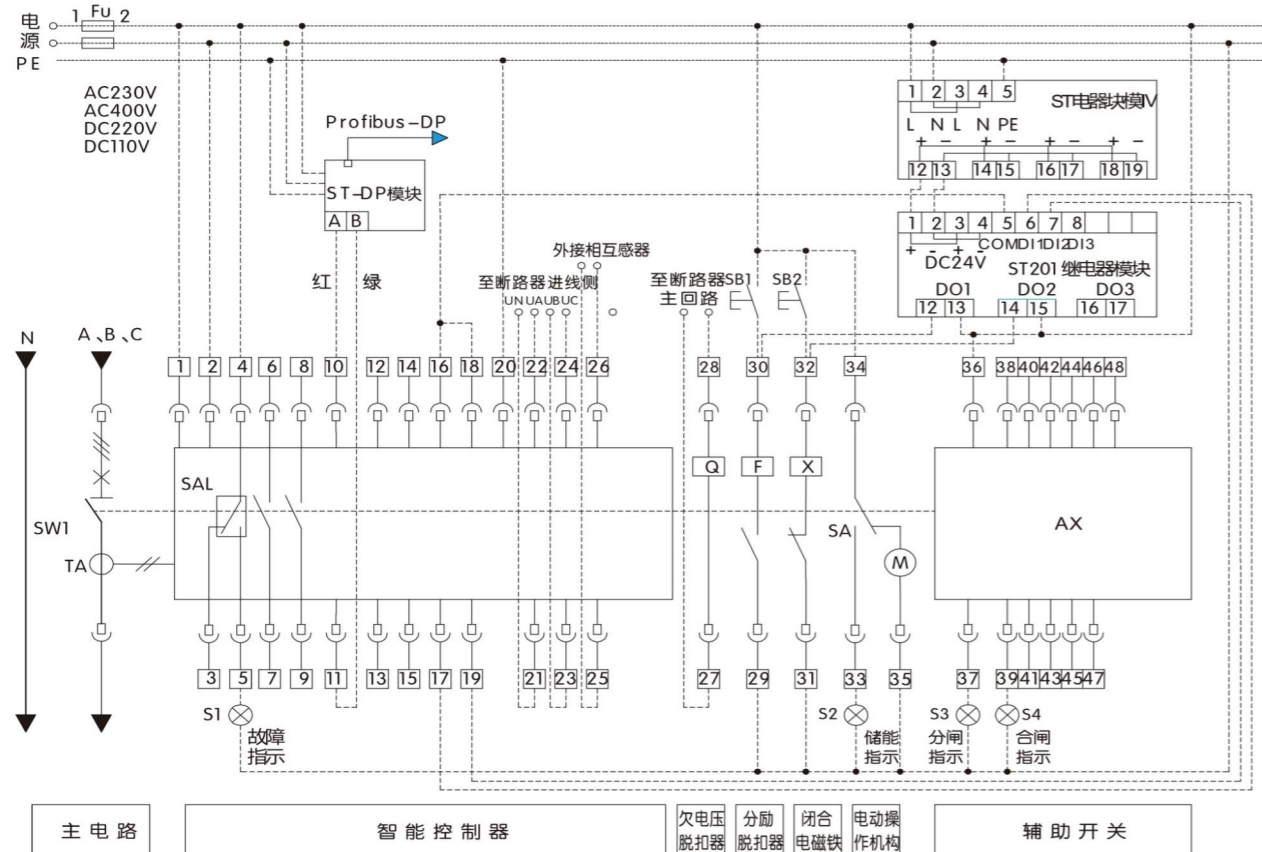

Terminal Number	Function Description	Symbol	Explanation	Remarks
1、2	Auxiliary power input: AC230V, AC400V, DC220V, DC110V	SW1	SW1 Universal Circuit Breaker	Customer self-provided
3、4、5	For DC power: 1 is (+), 2 is (-)	S1-S4	Signal lamp	Customer self-provided
10、11	Fault trip auxiliary contact, contact capacity: AC250V, 3A	TA	Current transformer	
12-15	Communication interface output, 10 is (+), 11 is (-)	SAL	Micro switch	Customer self-provided
14、15	DO1, Programmable signal output, contact capacity: AC250V, 3A	SB1	Open button	Customer self-provided
16、17	DO2, Programmable signal output, contact capacity: AC250V, 3A	SB2	Close button	Customer self-provided
18、19	DO3, Trip signal output, contact capacity: AC250V, 3A	X	Closing electromagnet	
20	DO4, Closing signal output, contact capacity: AC250V, 3A	F	Shunt release	
21、22、23、24	Grounding (PE)	Q	Undervoltage release	
25、26	Voltage signal measurement, 21 connect N phase, 22 connect A phase, 23 connect B phase, 24 connect C phase	M	Motor-operated mechanism	
27、28	External N-phase transformer input	SA	Travel switch of motor-operated mechanism	Customer self-provided
29、30	Undervoltage release	Fu	Fuse	Customer self-provided
31、32	Shunt release	PE	Grounding	
33、34、35	Closing electromagnet	N	Neutral line (N phase)	
36-48	Motor-operated mechanism (motor energy storage), 37 connect green wire, 38 connect black wire, 39 connect red wire	A, B, C	Phase line	
For customer optional use of AX auxiliary switch form	Auxiliary contact terminal	AX	Auxiliary switch	
		ST-DP Module	Required for Profibus-DP communication	
		ST-DP Module	Required for communication function	
		ST201 Relay Module	Required for communication function	

I: Four changeover contacts (default)

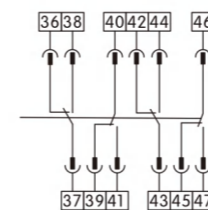

III: Three normally open and three normally closed contacts

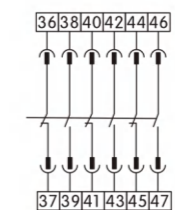

CQW2-1600 Series Fixed Type Overall Dimensions (Unit: mm)

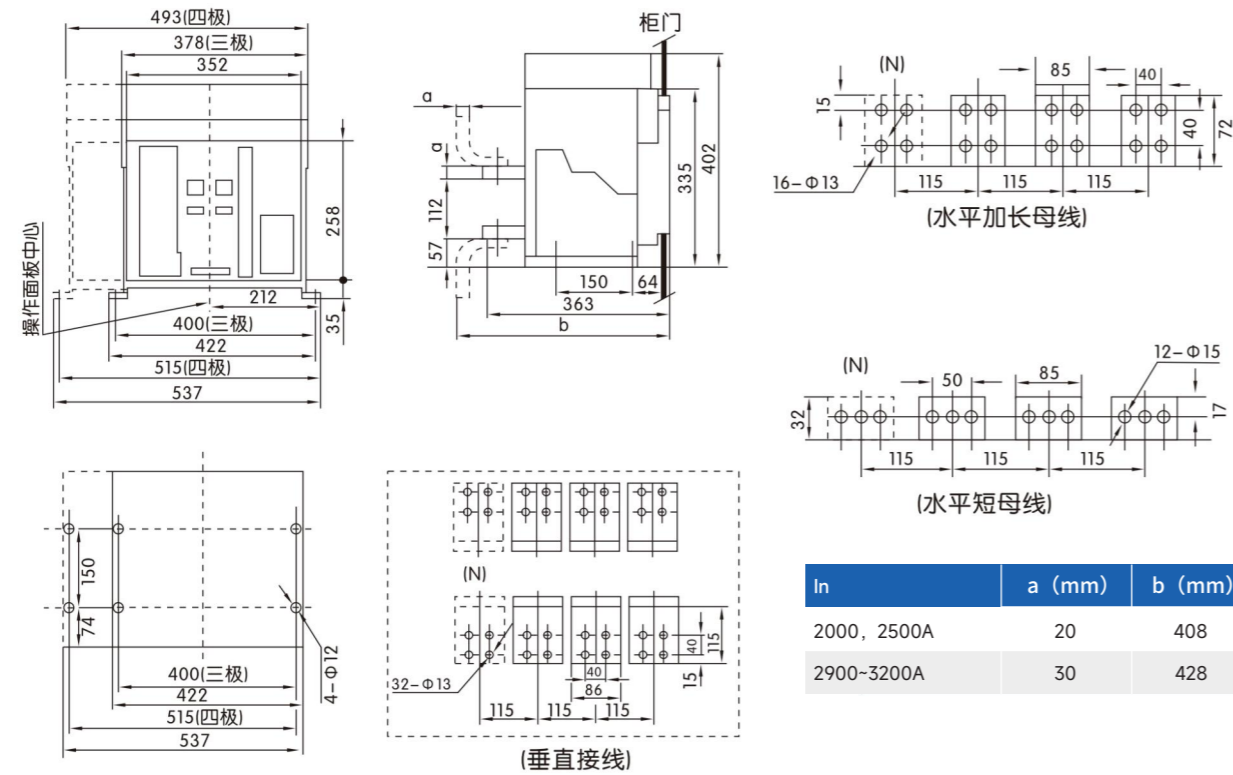

CQW2-4000 Series Drawout Type (3-Pole) Frame II Increased Capacity Type Overall Dimensions (Unit: mm)

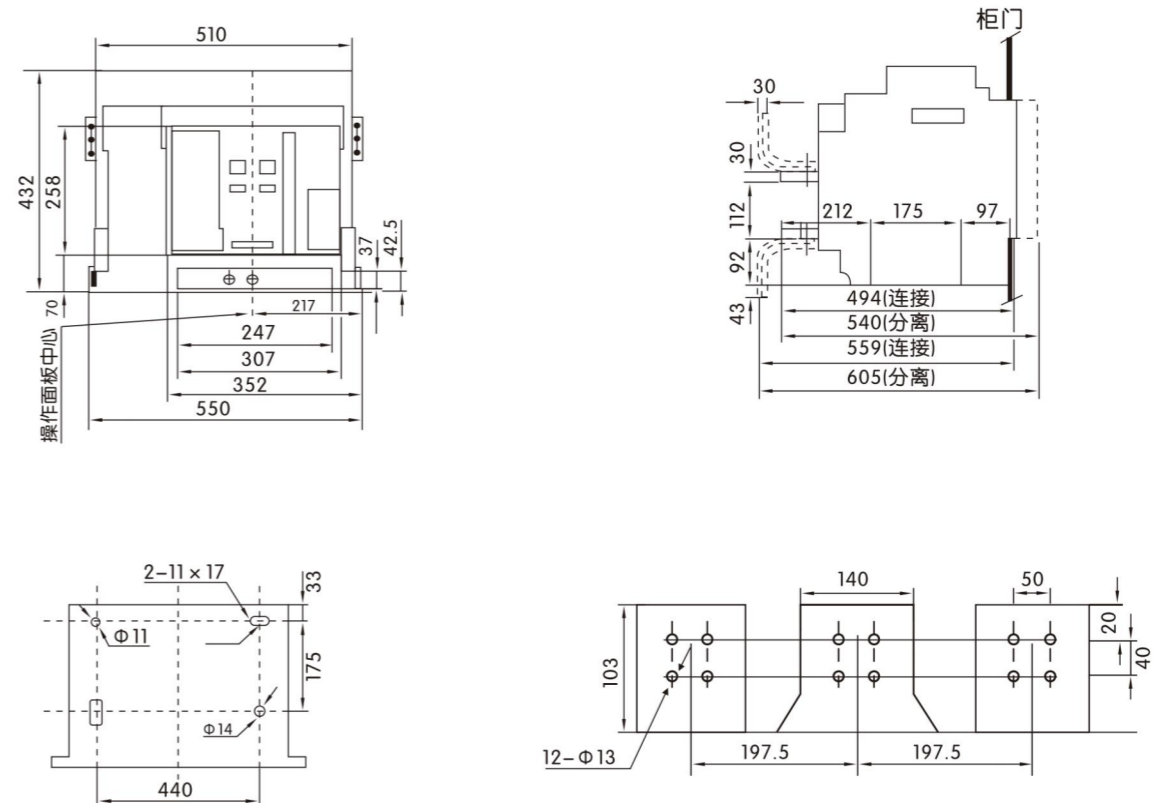

CQW2-1600 Series Drawout Type Installation Dimensions (Unit: mm)

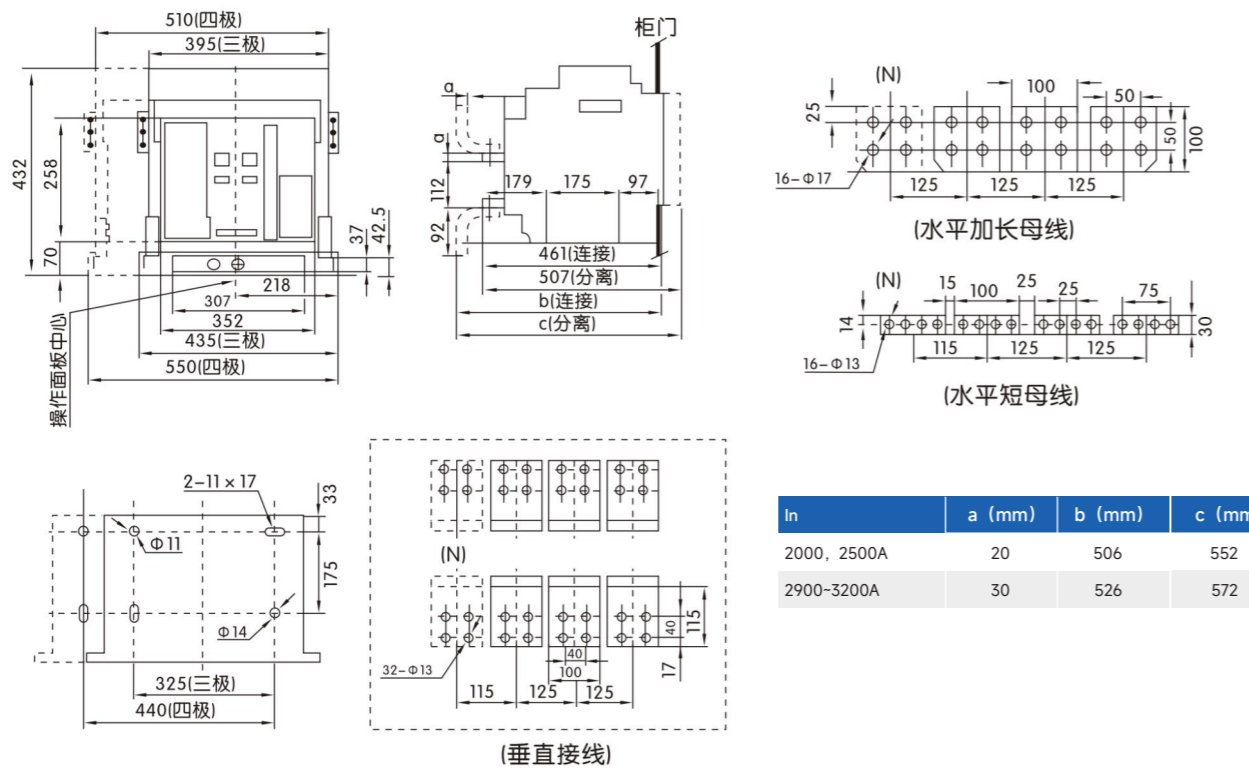

CQW2-4000 Series Drawout Type (4-Pole) Overall Dimensions (Unit: mm)

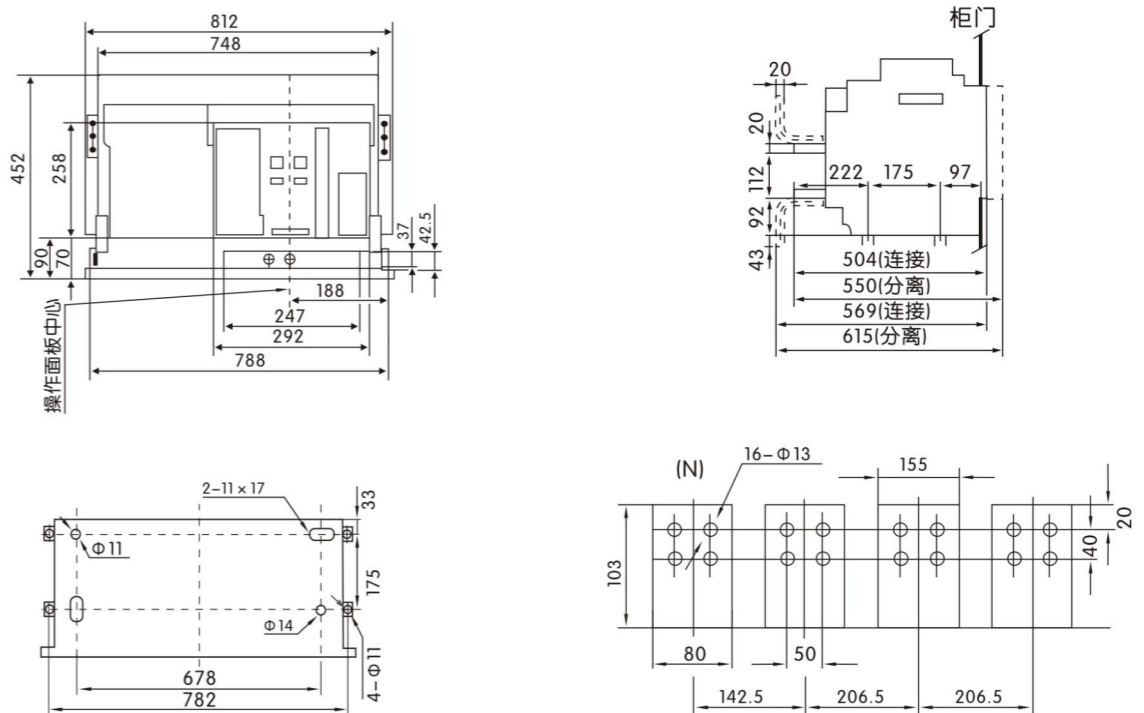

CQW2-6300 Series (In=5000A, 4000A) Drawout Type Overall Dimensions (Unit: mm)

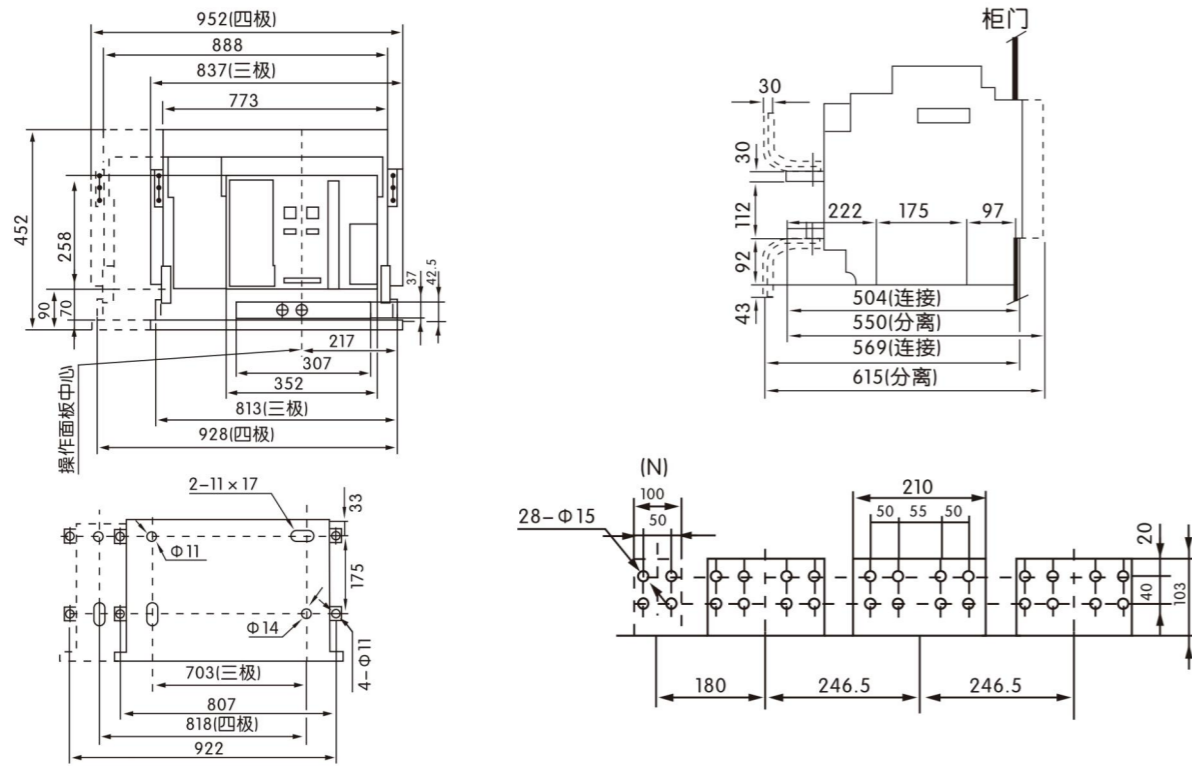

CQW2 Series Enclosure Door Frame Outline and Installation Dimensions (Unit: mm)

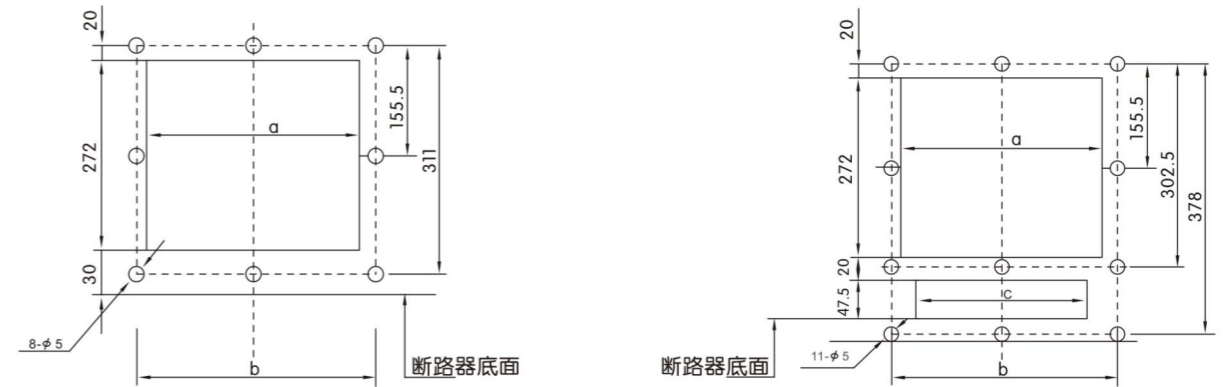

Model number	a	b	c
CQW2-2000	304	345	263
CQW2-3200、4000/3P	366	405	325
CQW2-4000/4P	304	345	263
CQW2-6300	366	405	325

CQW2-6300 Series (In=6300A) Drawout Type (3-Pole) Overall Dimensions (Unit: mm)

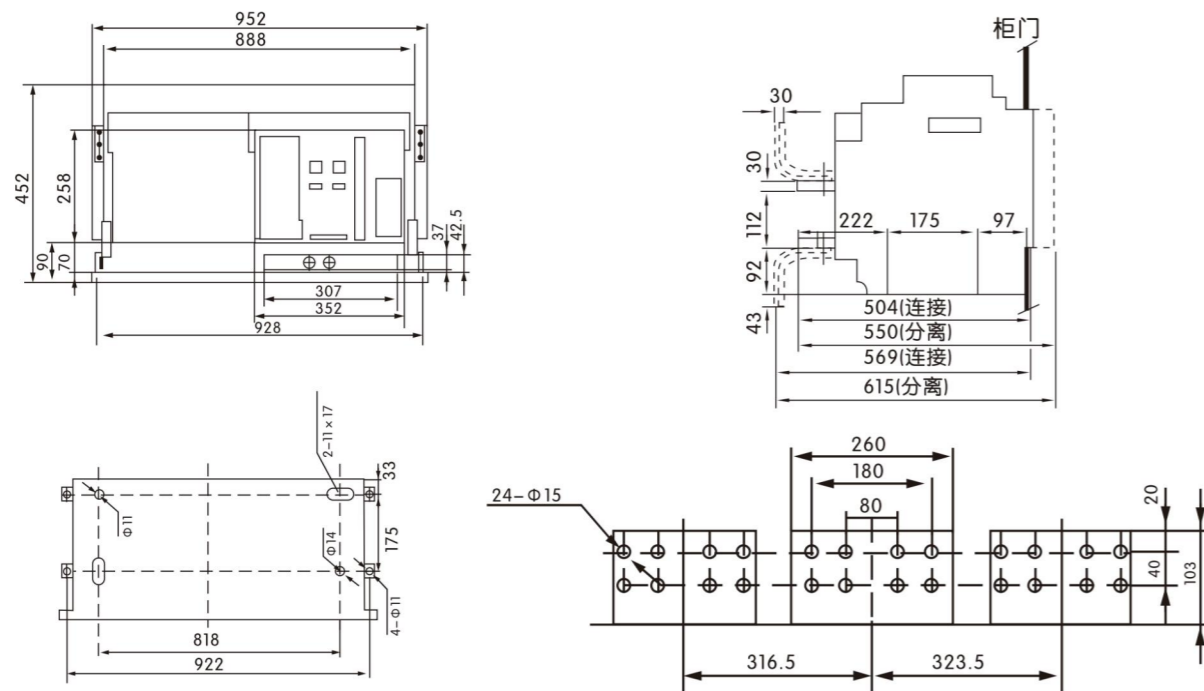

CQC6 Series

AC contactor



Key Specifications & Applications

- For 50Hz systems up to 690V, 95A rated current (AC-3, 380V).
- Remote circuit switching for resistive, inductive, and capacitive loads.
- It can be combined with thermal relays to form electromagnetic starters, providing reliable protection for circuits susceptible to overloads.
- Its primary function is to make and break circuits remotely, and it is suitable for resistive, inductive, and capacitive loads.

Main Technical Features

- Compact size, light weight, low power consumption, and long service life
- Easily expanded with auxiliary contacts, timers, or combined with thermal relays.
- Supports both screw and standard DIN rail mounting (Models 06-38: 35mm; Models 40-95: 35/75mm).
- Unibody cover for easy maintenance

Standard Operating and Installation Conditions

- Ambient Temperature: -5°C to +40°C (Range: -35°C to +70°C)
- Altitude: ≤2000m
- Protection Rating: IP20
- Pollution Degree: 3
- Installation Category: III

Technical Specifications

Model number	CQC6-06	CQC6-09	CQC6-12	CQC6-18	CQC6-25	CQC6-32	CQC6-38	CQC6-40	CQC6-50	CQC6-65	CQC6-80	CQC6-95					
Rated insulation voltage (Ui)	690V																
Rated impulse withstand voltage (Uimp)	8kV																
Rated frequency	50Hz,50/60Hz																
Number of poles (P)	3																
Rated Operational Current (A) - AC-3	220V/230V	6	9	12	18	25	32	38	40	50	65	80	95				
	380V/400V	6	9	12	18	25	32	38	40	50	65	80	95				
	660V/690V	4.8	6.6	8.9	12	18	20.2	20.2	34	39	42	49	49				
Conventional Free-Air Thermal Current (A) (AC-1, θ ≤ 60°C)	20	25	25	32	40	50	50	60	80	80	110	110					
Short-Time Withstand Current (A)	10s	80	105	105	145	145	260	310	320	400	520	640	800				
	1min	45	61	61	84	84	138	150	165	208	260	320	400				
	10min	20	30	30	40	40	60	60	72	84	110	135	135				
Controlled 3-Phase Squirrel Cage Motor Power (kW) - AC-3	220V/230V	1.5	2	3.5	4	6	7.5	9	11	15	18.5	22	25				
	380V/400V	2.2	4	5.5	7.5	11	15	18.5	18.5	22	30	37	45				
	660V/690V	3	5.5	7.5	10	15	18.5	18.5	30	33	37	45	45				
Short-circuit protection by gG fuses (U ≤ 690V) for Type 2 coordination, without integral thermal overload relay	20	25	25	32	40	50	50	60	80	80	110	110					
Electrical Endurance (10 ⁴ operations)	120			100					80								
Rated Making Capacity (AC-3)	10 × Ie, in accordance with IEC 60947-4-1 and GB/T 14048.4.																
Rated Breaking Capacity (AC-3)	8 × Ie, in accordance with IEC 60947-4-1 and GB/T 14048.4.																
Characteristics of AC controlcircuits																	
Operating Frequency (operations/h)	1200						600										
Mechanical Life (10 ⁴ operations, 3600 ops/h)	1200			1000			800			600							
	AC Coil Power (50/60Hz)			Pick-up (VA)			70			110			200			200	
			Sealed (VA)			8			11			20			20		
Operate Time (ms)	Close			12-22			12-22			20-35			20-35				
	Open			4-19			4-19			6-15			6-15				
Operate Voltage Range (50/60Hz)	Pick-up Voltage: 80%Us ~ 110%Us; Drop-out Voltage: 20%Us ~ 75%Us																
Rated Control Supply Voltage Us	AC 24/36/48/110/220/230/380/400/415/440V, 50/60Hz																
Applicable accessories	Auxiliary contact block	●	●	●	●	●	●	●	●	●	●	●	●				
	Coil surge absorber	●	●	●	●	●	●	●	●	●	●	●	●				
	Main circuit conductor	●	●	●	●	●	●	●	●	●	●	●	●				
	Mechanical interlock	●	●	●	●	●	●	●	●	●	●	●	●				
	Mechano-electrical interlock	●	●	●	●	●	●	●	●	●	●	●	●				
DIN rail mounting	●	●	●	●	●	●	●	●	●	●	●	●	●				
Certifications obtained	CCC CE CB																

Type designation

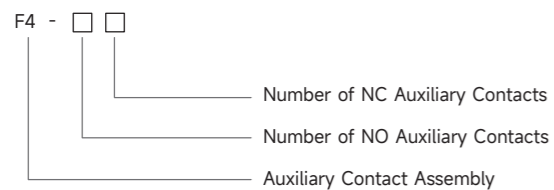
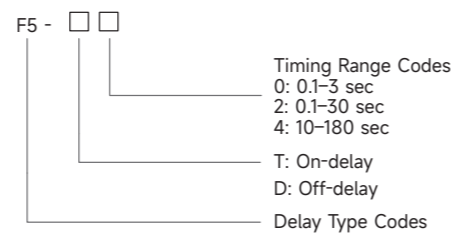
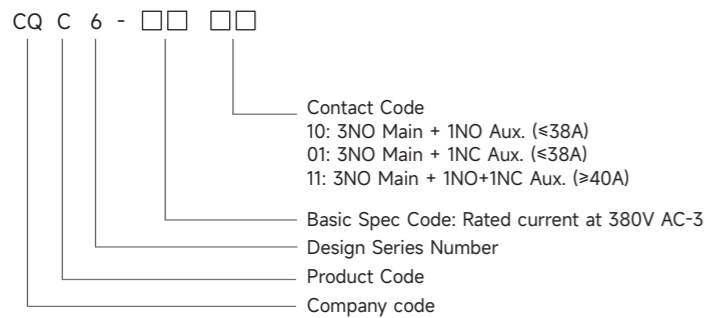

Dimensions (mm)

CQC6-06-25

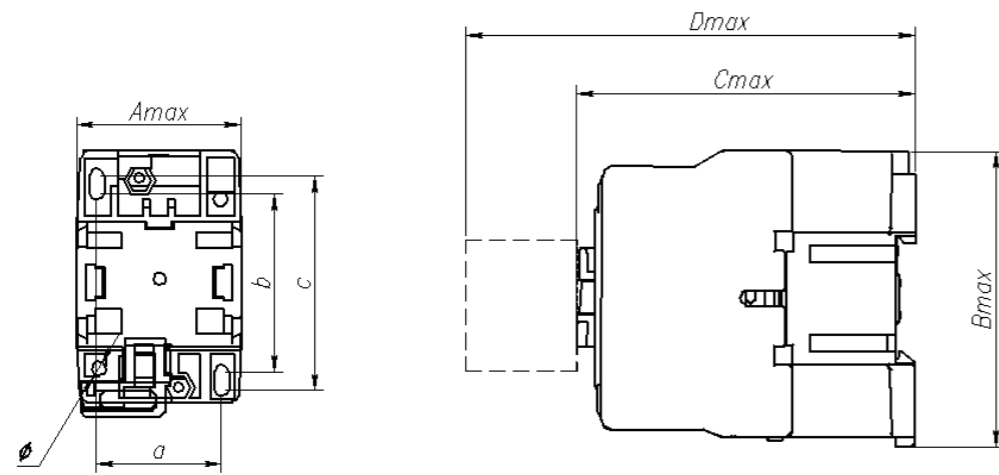

CQC6-40-95

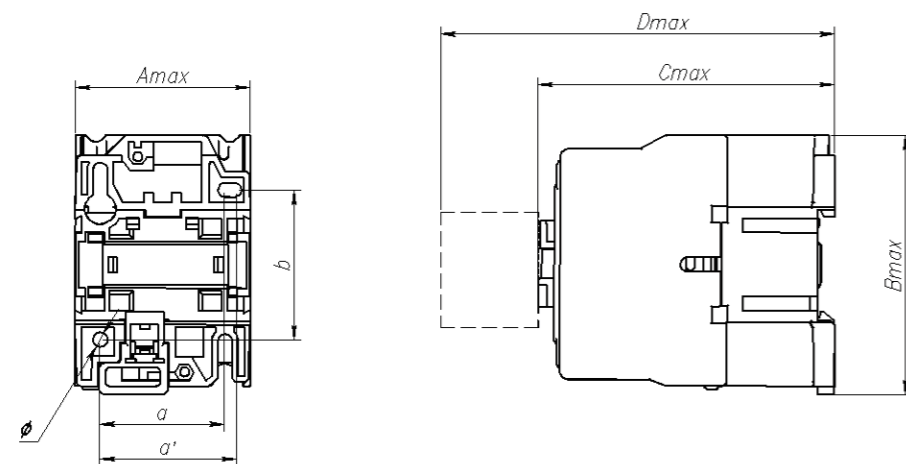
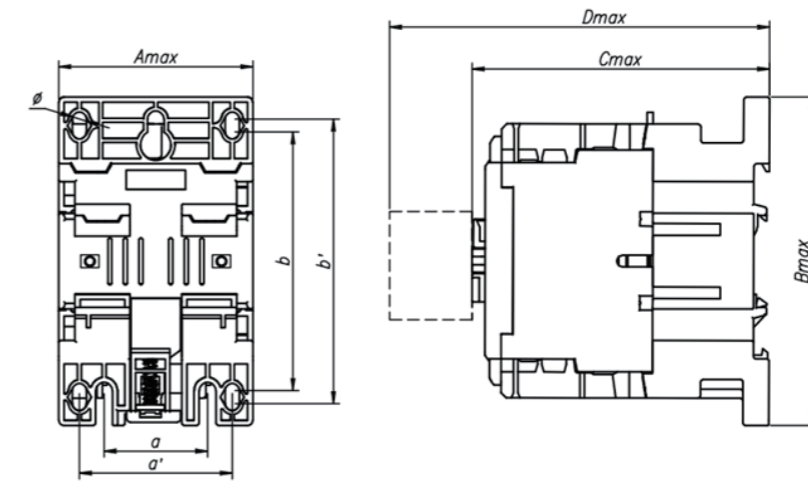

Model number	Amax	Bmax	Cmax	Dmax	a/a'	b	c	Φ
CQC6-06-25	46	76	83	117	35	50	60	Φ4.5
CQC6-32-38	57	85	96	130	40/43	48	/	Φ4.5
CQC6-40-65	76	128	115	149	40/59	100	110	Φ5.5
CQC6-80-95	85	128	124	158	40/67	100	110	Φ5.5

Accessories Description

Contact Configuration

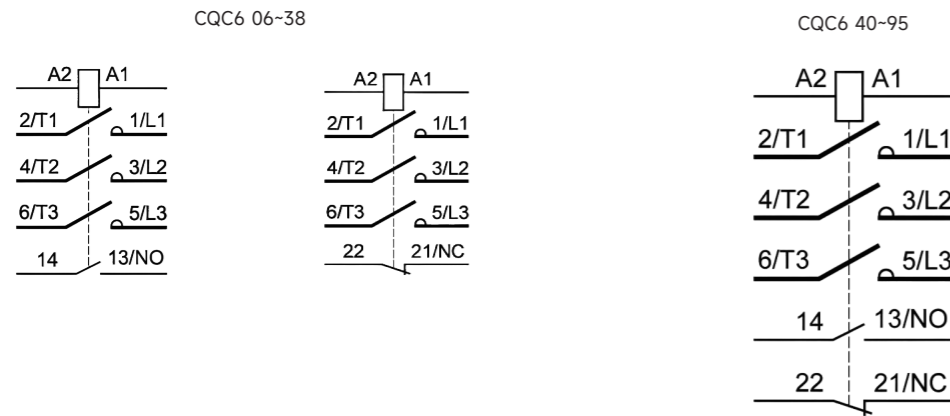

Main Circuit Conductor (Busbar)

Product Model	Upper Conductor			Lower Conductor			Conductor Dmax	Applicable Models
	Amax	Bmax	Cmax	Amax	Bmax	Cmax		
F1-H1	88	24	28	88	17	28	2.5mm ²	CQC6-06/18
F1-H2	103	29	33	103	20	35	6mm ²	CQC6-25/38
F1-H3	134	43	55	134	30	50	10mm ²	CQC6-40/65
F1-H4	150	52	51	150	37	50	16mm ²	CQC5-80/95

Installation Method & Dimension Diagram (Upper Conductor)

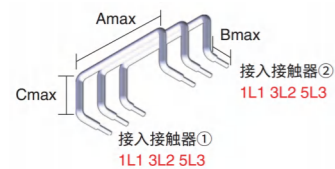

Installation Method & Dimension Diagram (Lower Conductor)

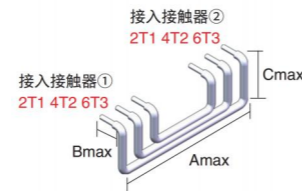

Electrical/Mechanical Interlock

Product Name	Content	Product Model	Applicable Models	Wiring Diagram (ME)
Electrical Interlock	Electrical Interlock Kit	F2-LS3	CQC6-06-38	
	Electrical Interlock Kit	F2-LS4	CQC6-40-95	
Mechanical Interlock	Mechanical Interlock Kit	F2-LS1	CQC6-06-38	
	Mechanical Interlock Kit	F2-LS2	CQC6-40-95	

Component size diagram (mm)

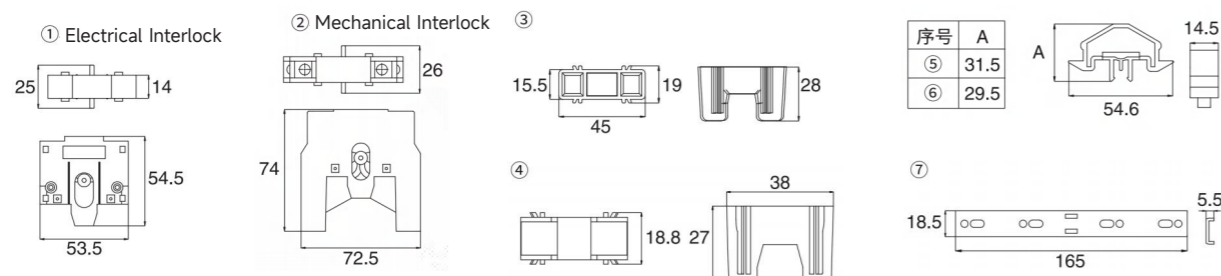

RC Snubber (Coil Surge Suppression)

Product Model	Content	Applicable Models	Dimensions (mm)
F3-LY2EA	AC 24...48V	CQC6-06-38	
F3-LY2GA	AC 50...127V		
F3-LY2UA	AC 110...240V		
F3-LY2NA	AC 380...415V		
F3-LY2FC	AC 24...48V	CQC6-40-95	
F3-LY2GC	AC 50...127V		
F3-LY2UC	AC 110...240V		
F3-LY2NC	AC 380...415V		

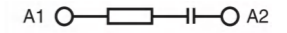

Auxiliary Contacts

Product Name	Product Model	Content	Applicable Models	Dimensions (mm)
Top-Mounted Auxiliary (2 Contacts)	F4-11	1NO + 1NC	CQC6-06-95	
	F4-20	2NO		
	F4-02	2NC		
Top-Mounted Auxiliary (4 Contacts)	F4-22	2NO + 2NC		
	F4-40	4NO		
	F4-04	4NC		
	F4-13	1NO + 3NC		
	F4-31	3NO + 1NC		

Electrical Parameters	Utilization Category	Rated Operational Voltage (V)	Rated Operational Current (A)
Conventional Thermal Current I _{th}	AC-15	380	0.95
Rated Insulation Voltage U _i		220	1.6
Rated Impulse Withstand Voltage U _{imp}	DC-13	220	0.15
Minimum Switchable Load		6V 100mA	

On-Delay Timer (Timer Head)

Product Model	Content	Applicable Models
F5-T0	0.1...3s	CQC6-06-95
F5-T2	0.1...30s	
F5-T4	10...180s	
F5-S2	1...30s	
F5-D0	0.1...3s	
F5-D2	0.1...30s	
F5-D4	10...180s	

Side-Mounted Auxiliary

Product Model	Content	Applicable Models
F8-11	1NO + 1NC	CQC6-06-95
F8-20	2NO	
F8-02	2NC	

CQR2 Series
Thermal overload relay

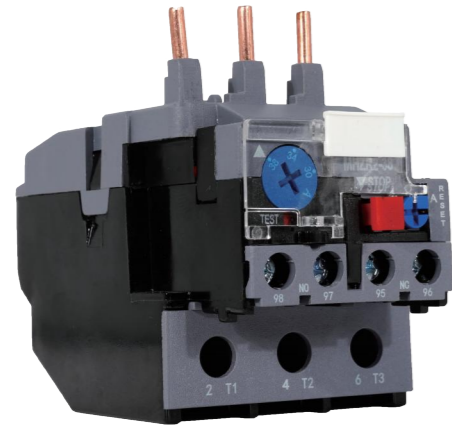

Type designation

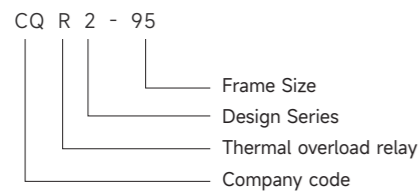

Technical Specifications

Product Model	CQR2-25	CQR2-38	CQR2-95		
Current rating	25	38	95		
Rated insulation voltage V	690	690	690		
Rated impulse withstand voltage V	6000	6000	6000		
Enclosure protection grade	IP20(Front side)	IP20(Front side)	IP20(Front side)		
Phase loss protection	●	●	●		
Manual and automatic reset	●	●	●		
Temperature compensation	●	●	●		
Tripping indication	●	●	●		
Test button	●	●	●		
Stop button	●	●	●		
Installation method	Insertable	Insertable	Insertable		
Auxiliary contact	1NO+1NC	1NO+1NC	1NO+1NC		
AC-15220V rated current A	2.73	2.73	2.73		
AC-15380V rated current A	1.58	1.58	1.58		
DC-13220V rated current A	0.2	0.2	0.2		
Cross-sectional area of conductor (mm ²)	Main circuit	Single-core or stranded wire	1 ~ 4	6-10	6-35
		Wire connection screw	M4	M4	M10
	Auxiliary circuit	Single-core or stranded wire	1 ~ 2.5	1-2.5	1-2.5
		Wire connection screw	M3.5	M3.5	M3.5

Product Features

- Comprehensive Motor Protection: Designed for three-phase squirrel-cage asynchronous motors, providing reliable overload and phase-failure protection.
- Wide Application Range: Suitable for AC systems up to 690V, with current ratings from 0.1A to 95A, supporting continuous or intermittent duty operations.
- Functional Versatility: Features temperature compensation, trip indication, automatic/manual reset, and a stop function for enhanced control and safety.
- Robust Design: Equipped with bimetallic strips (triple-phase), adjustable current settings, and auxiliary contacts (1NO + 1NC with electrical isolation).
- Easy Integration: Plug-in installation compatible with CQC6 series contactors for streamlined assembly.

Operating & Environmental Conditions

- Ambient Temperature: -5°C to +40°C (average temperature ≤ +35°C over 24h).
- Humidity: ≤50% at +40°C; ≤90% at lower temperatures (with condensation prevention).
- Altitude: Up to 2000m.
- Pollution Degree: Level 3.
- Method: Plug-in installation combined with MHZC5 series contactors.
- Enclosure Protection: IP20 (front-side).

Tripping Characteristics

Item	No.	Setting Current Multiple	Operating Time	Purpose / Test Condition	
Overload Protection	1	1.05	No operation within 2 hours	Starting from Cold State	
	2	1.2	Operation within 2 hours	Starting from Hot State (after Item 1)	
	3	1.5	Operation within 2 minutes	Starting after reaching thermal equilibrium at setting current	
	4	7.2	2S<TP≤10S	Starting from Cold State	
Phase Failure Protection	5	Any Two Phases 1.0	No operation within 2 hours	Starting from Cold State	
		One Phase 0.9			
	6	1.15	0	Operation within 2 hours	Starting from Hot State (after Item 5)

Adjustable Trip Setting Range

Product Model	Current adjustment range RC(A)	Plug-in contactors	Short-circuit protection fuse (A)	
			aM	gG
CQR2-25	0.1-0.16	CQC6(SM/KMNC1)-09 CQC6(SM/KMNC1)-12 CQC6(SM/KMNC1)-18 CQC6(SM/KMNC1)-25	0.25	2
	0.16-0.25		0.5	2
	0.25-0.40		1	2
	0.40-0.63		1	2
	0.63-1		2	4
	1-1.6		2	4
	1.6-2.5		4	6
	2.5-4		6	10
	4-6		8	16
	5.5-8		12	20
	7-10		12	20
	9-13		16	25
CQR2-38	12-18	CQC6(SM/KMNC1)-32	20	35
	17-25		25	50
CQR2-95	23-32	CQC6(SM/KMNC1)-40 CQC6(SM/KMNC1)-50 CQC6(SM/KMNC1)-65 CQC6(SM/KMNC1)-80 CQC6(SM/KMNC1)-95	40	63
	30-38		40	80
	17-25		25	50
	23-32		40	63
	30-40		40	100
	37-50		63	100
	48-65		63	100
	55-70		80	125
63-85	80	125		
80-95	100	160		

Selection Guide

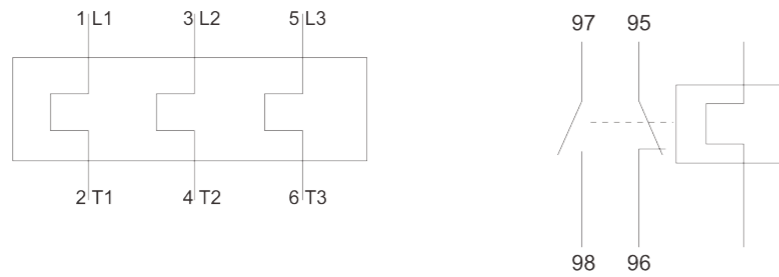

Instructions for Use

CQR2 Series Thermal Overload Relay Panel Symbols and Functional Button Description

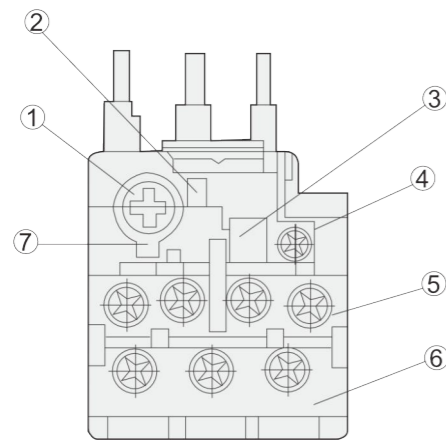

- ① Setting Current Adjustment Knob
- ② Trip Indication
- ③ Stop Button
- ④ Reset Button: A (Auto Reset) / H (Manual Reset)
- ⑤ Auxiliary Contact Terminals: 95, 96, 97, 98
 95, 96: Normally Closed (NC) Contacts
 97, 98: Normally Open (NO) Contacts
- ⑥ Main Circuit Terminal Numbers
- ⑦ Test Button

Trip Test (Performed BEFORE energizing the main circuit):

Open the cover. Press the test button with a screwdriver. The NC contacts will open and the NO contacts will close. The status change can be observed through the indicator window (yellow mark visible indicates tripped state; mark hidden indicates reset state - see illustration above).

Reset Mode Setting (Performed BEFORE energizing the main circuit):

The relay leaves the factory set to manual reset mode. To select automatic reset mode, press and hold the reset button while turning it clockwise 90°. It is not advisable to change the reset mode while the circuit is energized and running.





Setting Current Adjustment (Performed BEFORE energizing the main circuit):

The relay leaves the factory set to the minimum setting current. To select a different setting current value, open the cover and turn the current setting dial with a screwdriver. Align the arrow on the dial with the current value corresponding to the full-load rated current of the motor being protected.

Emergency Stop:

Press the Stop Button. Pressing the stop button only opens the NC contacts; it does not affect the NO contacts. Releasing the stop button resets the NC contacts.

Accessories Description

Application	Model number	Application
	MB-1	Combined with M12 to form an independent mounting product
	MB-2	Combined with M25 to form an independent mounting product
	MB-3	Combined with M38 to form an independent mounting product
	MB-4	Combined with M95 to form an independent mounting product

Dimensions (mm)

CQR2-25

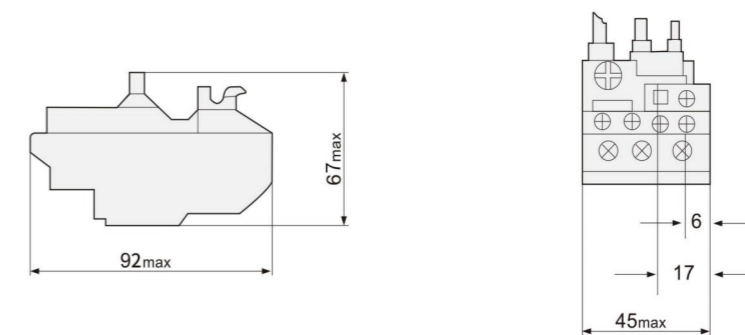

CQR2-38

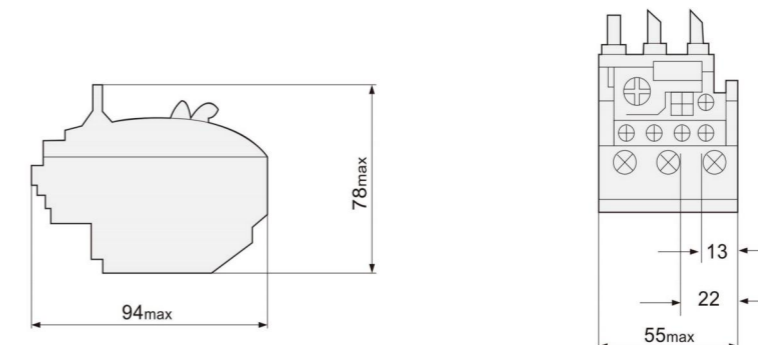

CQR2-95

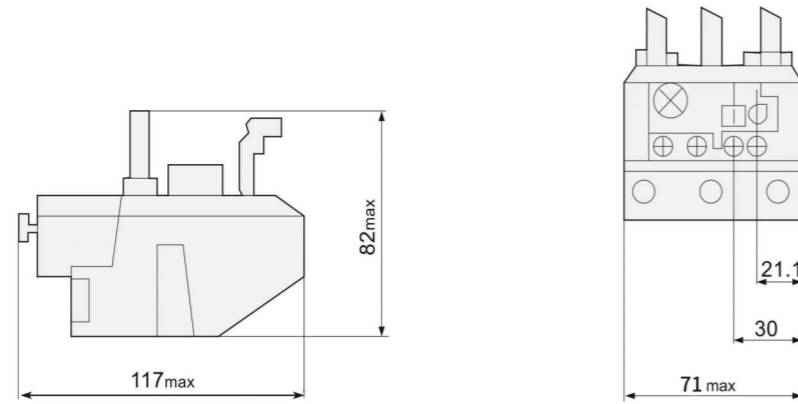

CQV2 Series Motor Protection Device



Accessories

- CQV-AE: Instantaneous Auxiliary Contact.
- CQV-AN/AD/AM: Combination of Signal Contacts for trouble and short-circuit signals.
- CQV-AU/AX/AS: Under-voltage Disjoining Accessory.
- Circuit Shield: Protective cover offering IP55 degree of protection.

Product Features

- Comprehensive Motor Protection: Specifically designed for three-phase squirrel-cage asynchronous motors, providing overload, phase-failure, and short-circuit protection.
- Control and Isolation Functionality: Suitable for infrequent motor starting and control, and can also serve as a distribution line protection switch and isolator.
- Wide Applicability: Compatible with AC circuits up to 690V and rated currents up to 80A.
- Flexible Configuration: Supports various accessories (e.g., auxiliary contacts A01, A02, etc.), enhancing functionality and signal feedback capabilities.
- Multiple Model Options: Offers a range of trip unit rated currents (from 2.5A to 80A) to precisely match motors of different power ratings (0.75kW to 32kW).
- Clear Tripping Characteristics: Provides tripping characteristic curves that define trip times at different current multiples, ensuring predictable and reliable protection.
- Compact Design: Features specific external mounting dimensions for easy installation in distribution boxes.



Operating & Environmental Conditions

- Protection Target: Primarily for three-phase low-voltage asynchronous motors.
- Operating Frequency: Suitable for infrequent starting, control, and load switching operations.
- Ambient Temperature: Tripping characteristics are defined based on a reference temperature of 20°C.
- Accessory Placement: Accessories (e.g., auxiliary contacts) are typically mounted on the right side of the circuit breaker.

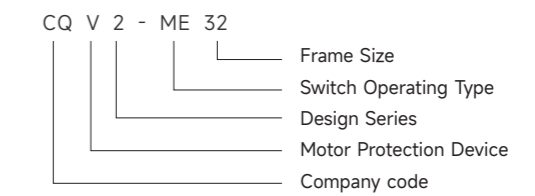
Type Designation



Technical Specifications

Product Model	Rated current (A)	Motor output (kW)	Setting Range(A)		Order Number	Packing parameters
			Thermal overload releases 	Instantaneous overcurrent releases 		
CQV2-ME32	0.16	0.04	0.1-0.16	1.9	CQV2-ME01	QTY:50PCS N.W:13.5KG G.W:15KG MEAS:48X27X19CM
	0.25	0.07	0.16-0.25	3.0	CQV2-ME02	
	0.4	0.09/0.12	0.25-0.4	4.8	CQV2-ME03	
	0.63	0.12/0.18	0.4-0.63	7.2	CQV2-ME04	
	1	0.25	0.63-1	12	CQV2-ME05	
	1.6	0.37/0.55	1-1.6	19	CQV2-ME06	
	2.5	0.75	1.6-2.5	30	CQV2-ME07	
	4.0	1.1/1.5	2.5-4	51	CQV2-ME08	
	6.3	2.2	4-6.3	78	CQV2-ME10	
	10	3/4	6-10	138	CQV2-ME14	
	14	4/6.5	9-14	170	CQV2-ME16	
	18	7/8	13-18	220	CQV2-ME20	
	23	8/10	17-23	320	CQV2-ME21	
	25	9/12	20-25	350	CQV2-ME22	
CQV2-ME80	32	15	24-32	420	CQV2-ME32	
	40	18.5	25-40	480	CQV2-ME40	
	63	28	40-63	720	CQV2-ME63	
	80	32	56-80	960	CQV2-ME80	QTY:30PCS N.W:23KG G.W:23.5KG MEAS:42X36X27.7CM

Accessories Description

CQV-AE: Instantaneous Auxiliary Contact.

CQV-AN/AD/AM: Combination of Signal Contacts for trouble and short-circuit signals.

Product Model	Accessory Name	Part Code	Contact Configuration	Mounting Position
CQV-AE	Instantaneous Auxiliary Contact	AE1	1NO or 1NC	Front
CQV-AE	Instantaneous Auxiliary Contact	AE11	1NO or 1NC	Front
CQV-AE	Instantaneous Auxiliary Contact	AE20	2NO	Front
CQV-AN (-AD-AM)	Trouble Signal Contact	AD1001	1NC (Fault)	Left
CQV-AN (-AD-AM)	Trouble Signal Contact	AD1010	1NO (Fault)	Left
CQV-AN (-AD-AM)	Instantaneous Auxiliary Contact	AM11	1NO + 1NC	Left

CQV-AU/AX/AS: Under-voltage Disjoining Accessory.

Product Model	Release Type	Part Code	Voltage	Operating Range
CQV2-AU (-AX-AS)	Undervoltage Release	AU225	220-240V AC	Operate: 0.85-1.1Ue; Trip: 0.35-0.7Ue
CQV2-AU (-AX-AS)	Undervoltage Release	AU385	380-415V AC	Operate: 0.85-1.1Ue; Trip: 0.35-0.7Ue
CQV2-AU (-AX-AS)	Shunt Release	AS115	220-240V AC	Operate: 0.75-1.1Ue; Trip: 0.2-0.75Ue
CQV2-AU (-AX-AS)	Shunt Release	AS225	220-240V AC	Operate: 0.75-1.1Ue; Trip: 0.2-0.75Ue
CQV2-AU (-AX-AS)	Shunt Release	AS385	220-240V AC	Operate: 0.75-1.1Ue; Trip: 0.2-0.75Ue

CQV2-MC02: Circuit Shield

Product Model	Application	Protection Type	Protection Rating	Packing Dimensions (cm)
CQV2-MC02	For CQV2 breakers with/without accessories (max 1/side)	Surface-mount, double-insulated, sealed cover	IP55	51 × 31.5 × 48.5

Tripping Characteristic Curve

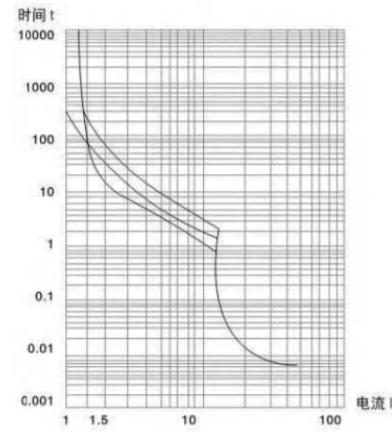

Test condition: Ambient temperature 20°C

Curve parameters (based on multiples of setting current I_n):

- (1) Starting from cold state, 3-pole
- (2) Starting from cold state, 2-pole
- (3) Starting from hot state, 3-pole

Tripping Characteristic Curve

Circuit Shield

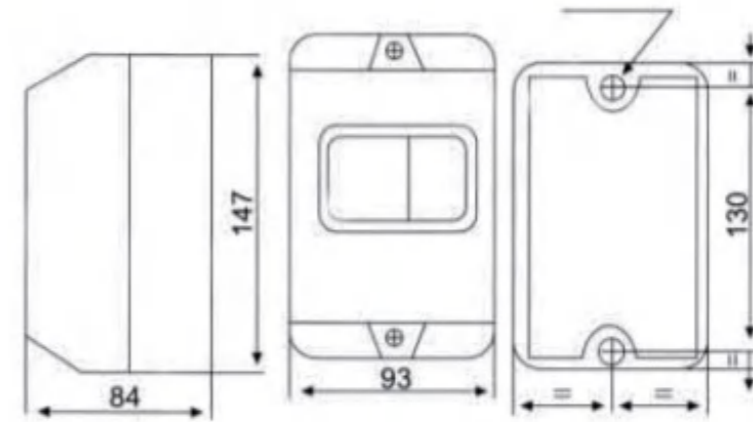

Dimensions (mm)

CQV2-ME

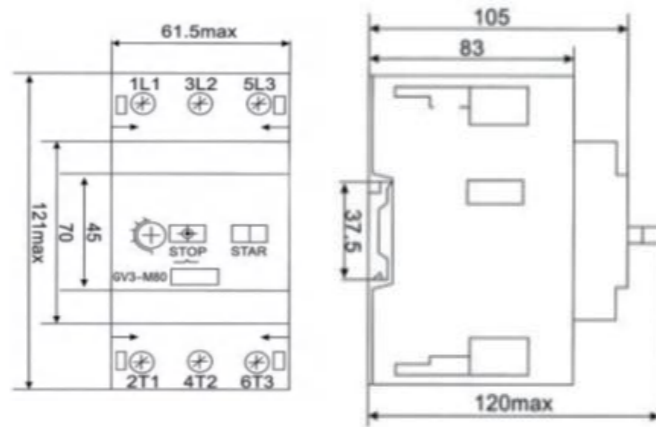

CQV-AU/AX/AS CQV-AN/AD/AM CQV-AE

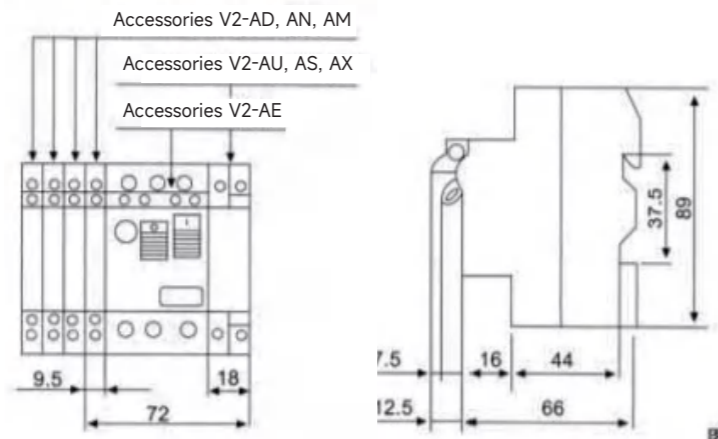

STE1 Series

High-voltage DC contactor (Square Ceramic Sealing)



Product Features

- Advanced Sealing Technology
 - Square ceramic-encapsulated design, offering superior high-temperature resistance and corrosion protection for environments $\geq 1500\text{VDC}$.
- Ultra-High Voltage Support
 - Operating voltage range: 750VDC to 1800VDC (e.g., STE1-400).
- High-Current Handling
 - Rated current: 40A-600A; peak breaking capacity up to 2500A (at 300VDC).
 - Short-term overload endurance (e.g., STE1-600: 800A for 20 minutes).

Type designation

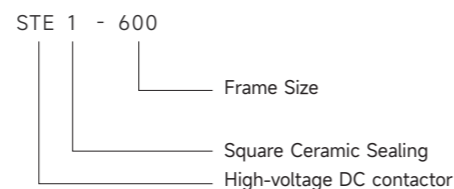

Technical Specifications

Product model	STE1-40	STE1-60	
Contact form	1H	1H	
Auxiliary contact	/	/	
Contact polarity	Non-polarity	Non-polarity	
Contact resistance	$\leq 5\text{m}\Omega$ (at 40A)	$\leq 5\text{m}\Omega$ (at 60A)	
Operating voltage	$\leq 75\%U_n$	$\leq 75\%U_n$	
Maximum breaking current	40A	60A	
Electrical endurance	10-1500V	10-1000V	
Maximum breaking current	400A(300VDC)	600A(300VDC)	
Electrical endurance	≥ 300 times(40A/1500VDC)	$\geq 1 \times 10^4$ times(60A/750VDC) $\geq 5 \times 10^3$ times(60A/1000VDC)*	
Current carrying	40A:Continuous for 60A:60min 160A:10s	60A:Continuous for 80A:20min 160A:40s	
Dielectric withstand voltage	Between open contacts	3000VAC	3000VAC
	Between contact coils	4000VAC	4000VAC
Mechanical Endurance	2×10^5 times	2×10^5 times	
Coil Voltage	12V, 24V	12V, 24V	
Coil power consumption	3W	3W	
Load extraction method	Internal thread	Internal thread	
Coil lead out method	Connector	Connector	
Weight	About 180g	About 180g	
Vibrate	10Hz-500Hz 49m/s^2	10Hz-500Hz 49m/s^2	
Humidity	5%-85%RH	5%-85%RH	
Humidity range	-40°C~+85°C	-40°C~+85°C	
External dimensions/mm	79.2×36.7×48	79.2×36.7×48	

Note: 1. The above parameters are all initial values, measured at room temperature of 23°C.
 2. Unless otherwise specified, the electrical durability tests are conducted on resistive loads with a on/off ratio of 0.6s:5.4s.

Product model	Working voltage	Working current	Load polarity	Coil polarity	Auxiliary contact
STE1-40	1500	40	Non-polarity	Non-polarity	/
STE1-60	1000	60	Non-polarity	Non-polarity	/
STE1-100	1000	100	Having polarity	Non-polarity	/
STE1-150	750	150	Non-polarity	Non-polarity	/
STE1-200	750	200	Having polarity	Non-polarity	/
STE1-L200	1000	200	Non-polarity	Non-polarity	1NO
STE1-L300	1000	300	Non-polarity	Non-polarity	1NO
STE1-X300	1000	300	Non-polarity	Non-polarity	/
STE1-300	1000	300	Having polarity	Having polarity	/
STE1-300D	1500	300	Non-polarity	Non-polarity	1NO
STE1-350	1500	350	Non-polarity	Having polarity	1NO
STE1-400	1500	400	Non-polarity	Non-polarity	1NO
STE1-600	1000	600	Having polarity	Having polarity	/

Technical Specifications

Product model	STE1-100	STE1-150	STE1-200
Contact form	1H	1H	1H
Auxiliary contact	/	/	/
Contact polarit	Having polarity	Non-polarity	Having polarity
Contact resistance	≤1mΩ(at 100A)	≤5mΩ(at 150A)	≤0.5mΩ(at 200A)
Operating voltage	≤75%Un	≤75%Un	≤75%Un
Maximum breaking current	100A	150A	200A
Electrical endurance	10~1000V	10~750V	10~750V
Maximum breaking current	1000A(300VDC)	1500A(300VDC)	2000A(300VDC)
Electrical endurance	≥6×10 ³ times(100A/750VDC) ≥5×10 ³ times(100A/1000VDC)	≥1.5×10 ³ times(150A/450VDC) ≥500 times(150A/750VDC)	≥1×10 ³ times(200A/450VDC) ≥500 times(200A/750VDC)
Current carrying	100A:Continuous for 120A:2h 200A:10min	150A:Continuous for 180A:2h 225A:15min	200A:Continuous for 250A:15min 320A:5min
Dielectric withstand voltage	Between open contacts	3000VAC	3000VAC
	Between contact coils	4000VAC	4000VAC
Mechanical Endurance	2X10 ⁵ times	2X10 ⁵ times	2X10 ⁵ times
Coil Voltage	12V,24V	12V,24V	12V,24V
Coil power consumption	4.5W	4.5W	6W
Load extraction method	Copper bar connection	Copper bar connection	Internal thread
Coil lead out method	Connector	Connector	Connector
Weight	About 400g	About 400g	About 350g
Vibrate	10Hz~500Hz 49m/s ²	10Hz~500Hz 49m/s ²	10Hz~500Hz 49m/s ²
Humidity	5%~85%RH	5%~85%RH	5%~85%RH
Humidity range	-40°C~+85°C	-40°C~+85°C	-40°C~+85°C
External dimensions (mm)	81.5×40×78.3	81.5×40×78.3	81×39×70

Note: 1.The above parameters are all initial values,measured at room temperature of 23°C.
2. Unless otherwise specified,the electrica durabilitytests are conductedon resistiveloads with a on/off ratio of 0.6s:5.4s.

Technical Specifications

Product model	STE1-L;200	STE1-L300
Contact form	1H	1H
Auxiliary contact	1NO	1NO
Contact polarit	Non-polarity	Non-polarity
Contact resistance	≤0.5mΩ(at 200A)	≤0.3mΩ(at 300A)
Operating voltage	≤75%Un	≤75%Un
Maximum breaking current	200A	300A
Electrical endurance	10~1000V	10~1000V
Maximum breaking current	1000A(300VDC)	2000A(300VDC)
Electrical endurance	≥5×10 ³ times(200A/450VDC) ≥1×10 ³ times(200A/750VDC) ≥300 times(200A/1000VDC)	≥2×10 ³ times(300A/450VDC) ≥700 times(300A/750VDC) ≥300 times(300A/1000VDC)
Current carrying	200A:Continuous for 300A:30min 400A:5min	300A:Continuous for 450A:5min 600A:1min
Dielectric withstand voltage	Between open contacts	4000VAC
	Between contact coils	4000VAC
Mechanical Endurance	2X10 ⁵ times	2X10 ⁵ times
Coil Voltage	12V,24V	12V,24V
Coil power consumption	3w	4.5W
Load extraction method	Internal thread	Internal thread
Coil lead out method	lead wire	lead wire
Weight	About 185g	About 320g
Vibrate	10Hz~500Hz 49ms ²	10Hz~500Hz 49m/s ²
Humidity	5%~85%RH	5%~85%RH
Humidity range	-40°C~+85°C	-40°C~+85°C
External dimensions (mm)	71.8×36×51	83.4×48×63.5

Note: 1.The above parameters are all initial values,measured at room temperature of 23°C.
2. Unless otherwise specified,the electrica durabilitytests are conductedon resistiveloads with a on/off ratio of 0.6s:5.4s.

Technical Specifications

Product model	STE1-X300	STE1-300	STE1-300D
Contact form	1H	1H	1H
Auxiliary contact	/	/	1NO
Contact polarit	Non-polarity	Having polarity	Non-polarity
Contact resistance	≤0.5mΩ(at 300A)	≤0.2mΩ(at 300A)	≤0.3mΩ(at 300A)
Operating voltage	≤75%Un	≤75%Un	≤75%Un
Maximum breaking current	300A	300A	300A
Electrical endurance	10-1000V	10-1000V	10-1500V
Maximum breaking current	2000A(300VDC)	2500A(300VDC)	2000A(300VDC)
Electrical endurance	≥1×10 ⁵ times(300A/450VDC) ≥500 times(300A/750VDC) ≥100 times(300A/1000VDC)	≥6×10 ³ times(300A/750VDC) ≥3×10 ³ times(300A/1000VDC)	≥1.4×10 ³ times(250A/800VDC) ≥1×10 ³ times(400A/1000VDC) ≥500 times(400A/1500VDC)
Current carrying	300A:Continuous for 450A:5min 600A:2min	300A:Continuous for 600A:1min 900A:10s	400A:Continuous for 600A:1h 800A:10min
Dielectric withstand voltage	Between open contacts	3000VAC	3000VAC
	Between contact coils	3000VAC	4000VAC
Mechanical Endurance	2X10 ⁵ times	2X10 ⁵ times	2X10 ⁵ times
Coil Voltage	12V,24V	12V,24V	12V,24V
Coil power consumption	6W	Connect 46Wand maintain 4.5W	10W
Load extraction method	Internal thread	Copper bar connection	Internal thread
Coil lead out method	Connector	Connector	Connector
Weight	About 370g	About 850g	About 700g
Vibrate	10Hz-500Hz 49m/s ²	10Hz-500Hz 49m/s ²	10Hz-500Hz 49m/s ²
Humidity	5%-85%RH	5%-85%RH	5%-85%RH
Humidity range	-40°C--+85°C	-40°C--+85°C	-40°C--+85°C
External dimensions (mm)	88.3×42.5×74.5	112.6×64.7×83.9	98.4×45×91.5

Note: 1.The above parameters are all initial values,measured at room temperature of 23°C.
2. Unless otherwise specified,the electrica durabilitytests are conductedon resistiveloads with a on/off ratio of 0.6s:5.4s.

Technical Specifications

Product model	STE1-350	STE1-400	STE1-600
Contact form	1H	1H	1H
Auxiliary contact	1NO	1NO	/
Contact polarit	The coil has polarity while the contacts have no polarity	Non-polarity	Having polarity
Contact resistance	≤0.3mΩ(at 350A)	≤0.2m(at 400A)	≤0.2mΩ(at 600A)
Operating voltage	≤75%Un	≤75%Un	≤75%Un
Maximum breaking current	400A	400A	600A
Electrical endurance	10-1500V	10-1800V	10-1500V
Maximum breaking current	2000A(300VDC)	2500A(300VDC)	2500A(300VDC)
Electrical endurance	≥100 times(150A/1800VDC) ≥1×10 ³ times(400A/1000VDC) ≥500 times(400A/1500VDC)	≥100 times(150A/1800VDC) ≥1×10 ³ times(400A/1000VDC) ≥500 times(400A/1500VDC)	≥1×10 ³ times(600A/750VDC) ≥500 times(600A/1000VDC) ≥100 times(600A/1500VDC)
Current carrying	400A:Continuousfor 450A:60min 600A:2min	400A:Continuous for 450A:10min 600A:90s	600A:Continuous for 800A:20min 1000A:5min
Dielectric withstand voltage	Between open contacts	4000VAC	4000VAC
	Between contact coils	4000VAC	4000VAC
Mechanical Endurance	2X10 ⁵ times	2X10 ⁵ times	2X10 ⁵ times
Coil Voltage	12V,24V	12V,24V	12V,24V
Coil power consumption	Connect 46W and maintain4.5W	10W	Connect 50W and maintain 10W
Load extraction method	Internal thread	Intemal thread	Internal thread
Coil lead out method	Connector	Connector	lead wire
Weight	About 730g	About 850g	About 1020g
Vibrate	10Hz-500Hz 49m/s ²	10Hz-500Hz 49m/s ²	10Hz-500Hz 49m/s ²
Humidity	5%-85%RH	5%-85%RH	5%-85%RH
Humidity range	-40°C--+85°C	-40°C--+85°C	-40°C--+85°C
External dimensions (mm)	104×65×97.4	108×67×101.6	194.4×66.8×121.5

Note: 1.The above parameters are all initial values,measured at room temperature of 23°C.
2. Unless otherwise specified,the electrica durabilitytests are conductedon resistiveloads with a on/off ratio of 0.6s:5.4s.

STE2 Series
High-voltage DC contactor
(Round Epoxy Sealing)



Product Features

- **Reliable Encapsulation**
 - Round epoxy-sealed construction, ensuring IP-rated dust/water resistance for industrial applications.
- **Wide Operating Range**
 - Voltage: 12-1500VDC; current: 50-800A (e.g., STE2-800: 1000VDC/800A).
 - Fully non-polarized load support.
- **Harsh-Environment Ready**
 - Operating temperature: -45°C to +85°C; humidity: 5-95% RH.
- **Extended Electrical Life**
 - Electrical endurance: 100,000 cycles (e.g., STE2-500 at 750VDC/500A).
 - Low coil consumption (≤6W for most models).
- **Easy Installation**
 - External-thread terminals (STE2-150+) for rapid wiring.

Type designation

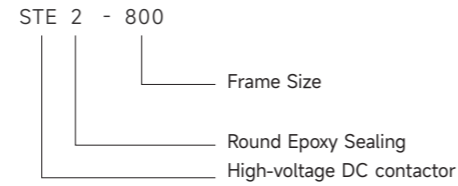

Product model	Working voltage	Working current	Load polarity	Coil polarity	Auxiliary contact
STE2-50	1500	50	Non-polarity	Non-polarity	/
STE2-100	1500	100	Non-polarity	Non-polarity	/
STE2-150	1500	150	Non-polarity	Non-polarity	/
STE2-200	1500	200	Non-polarity	Non-polarity	1NO
STE2-250	1500	250	Non-polarity	Non-polarity	1NO
STE2-300	1500	300	Non-polarity	Non-polarity	1NO
STE2-400	1500	400	Non-polarity	Non-polarity	1NO
STE2-500	1500	500	Non-polarity	Non-polarity	1NO
STE2-600	1500	600	Non-polarity	Non-polarity	1NO
STE2-800	1000	800	Non-polarity	Non-polarity	1NO

Technical Specifications

Product model		STE2-50	STE2-100
Contact form		1H	1H
Auxiliary contact		/	NO
Contact polarity		Non-polarity	Non-polarity
Contact resistance		≤1mΩ(at 50A)	≤1mΩ(at 100A)
Operating voltage		≤75%Un	≤75%Un
Maximum breaking current		50A	100A
Electrical endurance		12-1500V	12-1500V
Maximum breaking current		500A(320V DC)	1000A(320V DC)
Electrical endurance		≥1×10 ⁵ times(50A/750VDC) ≥400 times(20A/1000VDC) ≥150 times(10A/1500VDC)	≥2×10 ⁵ times(100A/750VDC) ≥1×10 ⁵ times(100A/1000VDC) ≥600 times(15A/1500VDC)
Current carrying		50A:Continuous for 100A:10min 200A:50s	100A:Continuous for 150A:10min 300A:50s
Dielectric withstand voltage	Between open contacts	3500VAC	3500VAC
	Between contact coils	3500VAC	3500VAC
Mechanical Endurance		2X10 ⁵ times	2X10 ⁵ times
Coil Voltage		12V,24V	12V,24V,48V
Coil power consumption		12V:5.5w 24V:6w	12V:5.5w 24V:6.0w
Load extraction method		Internal thread	Internal thread
Coil lead out method		lead wire	lead wire
Weight		About 115g	About 160g
Vibrate		80Hz-2000Hz 49/s ²	80Hz-2000Hz 49/s ²
Humidity		5%-95%RH	5%-95%RH
Humidity range		-45°C~+85°C	-45°C~+85°C
External dimensions (mm)		51.6X35.6X43.2	53.8X35.6X58.5

Note: 1.The above parameters are all initial values,measured at room temperature of 23°C.
2. Unless otherwise specified,the electrical durability tests are conducted on resistive loads with a on/off ratio of 0.6s:5.4s.

Technical Specifications

Product model		STE2-150	STE2-200	STE2-250
Contact form		1H	1H	1H
Auxiliary contact		NO	NO	NO
Contact polarit		Non-polarity	Non-polarity	Non-polarity
Contact resistance		≤1mΩ(at 150A)	≤1mΩ(at 200A)	≤1mΩ(at 250A)
Operating voltage		≤75%Un	≤75%Un	≤75%Un
Maximum breaking current		150A	200A	250A
Electrical endurance		12~1500V	12~1500V	12~1500V
Maximum breaking current		1000A(320VDC)	2000A(320VDC)	2000A(320VDC)
Electrical endurance		≥2×10 ³ times(100A/750VDC) ≥1×10 ³ times(150A/1000VDC) ≥600 times(30A/1500VDC)	≥2×10 ³ times(200A/750VDC) ≥1×10 ³ times(200A/1000VDC) ≥1×10 ³ times(50A/1500VDC)	≥2×10 ³ times(250A/750VDC) ≥1×10 ³ times(250A/1000VDC) ≥1×10 ³ times(50A/1500VDC)
Current carrying		150A:Continuous for 180A:10min 300A:50s	200A:Continuous for 300A:10min 400A:180s	250A:Continuous for 300A:10min 400A:180s
Dielectric withstand voltage	Between open contacts	3500VAC	3500VAC	3500VAC
	Between contact coils	3500VAC	3500VAC	3500VAC
Mechanical	Endurance	2X10 ⁵ times	2X10 ⁵ times	2X10 ⁵ times
Coil Voltage		12V,24V,36V,48V	12V,24V,36V,48V	12V,24V,36V,48V
Coil power consumption		12V,24,48V:5.76w 36V:2.5w	6w	6w
Load extraction method		External thread	External thread	External thread
Coil lead out method		lead wire	lead wire	lead wire
Weight		About 430g	About 430g	About 430g
Vibrate		80Hz~2000Hz 49/s ²	80Hz~2000Hz 49/s ²	80Hz~2000Hz 49/s ²
Humidity		5%-95%RH	5%-95%RH	5%-95%RH
Humidity range		-45°C~+85°C	-45°C~+85°C	-45°C~+85°C
External dimensions (mm)		53.8X35.2X59.5	80.5X63.6X73.8	80.5X63.6X73.8

Note: 1.The above parameters are all initial values,measured at room temperature of 23°C.
2. Unless otherwise specified,the electrica durabilitytests are conductedon resistiveloads with a on/off ratio of 0.6s:5.4s.

Technical Specifications

Product model		STE2-300	STE2-400
Contact form		1H	1H
Auxiliary contact		NO	NO
Contact polarit		Non-polarity	Non-polarity
Contact resistance		≤1mΩ(at 300A)	≤1mΩ(at 400A)
Operating voltage		≤75%Un	≤75%Un
Maximum breaking current		300A	400A
Electrical endurance		12~1500V	12~1500V
Maximum breaking current		2000A(320V DC)	2500A(320V DC)
Electrical endurance		≥2×10 ³ times(300A/750VDC) ≥1×10 ³ times(300A/1000VDC) ≥1×10 ³ times(80A/1500VDC)	≥3×10 ³ times(400A/750VDC) ≥1×10 ³ times(400A/1000VDC) ≥1×10 ³ times(200A/1500VDC)
Current carrying		300A:Continuous for 350A:10min 400A:180s	400A:Continuous for 500A:10min 600A:180s
Dielectric withstand voltage	Between open contacts	3500VAC	3500VAC
	Between contact coils	3500VAC	3500VAC
Mechanical	Endurance	2X10 ⁵ times	2X10 ⁵ times
Coil Voltage		12V,24V,36V,48V	12V,24V,36V
Coil power consumption		6w	3w
Load extraction method		External thread	External thread
Coil lead out method		lead wire	lead wire
Weight		About 430g	About 990g
Vibrate		80Hz~2000Hz 49/s ²	80Hz~2000Hz 49/s ²
Humidity		5%-95%RH	5%-95%RH
Humidity range		-45°C~+85°C	-45°C~+85°C
External dimensions (mm)		80.5X63.6X73.8	66.6X78.1X104.5

Note: 1.The above parameters are all initial values,measured at room temperature of 23°C.
2. Unless otherwise specified,the electrica durabilitytests are conductedon resistiveloads with a on/off ratio of 0.6s:5.4s.

Technical Specifications

Product model		STE2-500	STE2-600	STE2-800
Contact form		1H	1H	1H
Auxiliary contact		NO	NO	NO
Contact polarit		Non-polarity	Non-polarity	Non-polarity
Contact resistance		≤1mΩ(at 500A)	≤1mΩ(at 600A)	≤1m(at 800A)
Operating voltage		≤75%Un	≤75%Un	≤75%Un
Maximum breaking current		500A	600A	800A
Electrical endurance		12-1500V	12-1500V	12-1500V
Maximum breaking current		2500A(320VDC)	2500A(320V DC)	2500A(320V DC)
Electrical endurance		≥2×10 ⁵ times(500A/750VDC) ≥1×10 ⁵ times(500A/1000VDC) ≥1×10 ⁵ times(250A/1500VDC)	≥2×10 ⁵ times(600A/750VDC) ≥1×10 ⁵ times(600A/1000VDC) ≥1×10 ⁵ times(300A/1500VDC)	≥600 times(800A/750VDC) ≥1×10 ⁵ times(450A/1000VDC) ≥200 times(350A/1500VDC)
Current carrying		500A:Continuous for 550A:10min 600A:180s	600A:Continuous for 650A:10min 700A:180s	800A:Continuous for 900A:10min1000A:120s
Dielectric withstand voltage	Between open contacts	3500VAC	3500VAC	3500VAC
	Between contact coils	3500VAC	3500VAC	3500VAC
Mechanical Endurance		2X10 ⁵ times	2X10 ⁵ times	2X10 ⁵ times
Coil Voltage		12V,24V,36V	12V,24V,36V	12V,24V,36V
Coil power consumption		3w	3w	3w
Load extraction method		External thread	External thread	External thread
Coil lead out method		lead wire	lead wire	lead wire
Weight		About 990g	About 990g	About 990g
Vibrate		80Hz-2000Hz 49/s ²	80Hz-2000Hz 49/s ²	80Hz-2000Hz 49/s ²
Humidity		5%-95%RH	5%-95%RH	5%-95%RH
Humidity range		-45°C~+85°C	-45°C~+85°C	-45°C~+85°C
External dimensions (mm)		66.6X78.1X104.5	66.6X78.1X104.5	66.6X78.1X104.5

Note: 1.The above parameters are all initial values,measured at room temperature of 23°C.
2. Unless otherwise specified,the electrica durabilitytests are conductedon resistiveloads with a on/off ratio of 0.6s:5.4s.

STE3 Series High-voltage DC contactor (Round Ceramic Sealing)



Product Features

- Superior Protection
 - Ceramic sealing + polarized load design (all models), rated for 1000VDC
- High Surge Current Tolerance
 - Short-term withstand: e.g., STE3-250 handles 400A for 10min + 800A for 10s.
- Energy-Saving Operation
 - Coil power: 45W pickup / 2.8W holding(>75% energy reduction).
- Compact & Lightweight
 - Minimal footprint

Product model	Working voltage	Working current	Load polarity	Coil polarity	Auxiliary contact
STE3-50	1000	50	Having polarity	Non-polarity	/
STE3-100	1000	100	Having polarity	Non-polarity	/
STE3-150	1000	150	Non-polarity	Non-polarity	1NO
STE3-200	1000	200	Non-polarity	Non-polarity	1NO
STE3-250	1000	250	Non-polarity	Non-polarity	1NO
STE3-300	1000	300	Non-polarity	Non-polarity	1NO
STE3-350	750	350	Non-polarity	Non-polarity	1NO

Technical Specifications

Product model		STE3-50	STE3-100
Contact form		1H	1H
Auxiliary contact		/	/
Contact polarit		Having polarity	Having polarity
Contact resistance		≤3mQ(at 50A)	≤3mQ(at 100A)
Operating voltage		≤75%Un	≤75%Un
Maximum breaking current		50A	100A
Electrical endurance		10-1000V	10-1000V
Maximum breaking current		1000A(300VDC)	1000A(300VDC)
Electrical endurance		600 times(1000V,50A)	500 times(1000V,50A)
Current carrying		50A:Continuous for 200A:10min 300A:10s	100A:Continuous for 200A:10min300A:10s
Dielectric withstand voltage	Between open contacts	2500VAC	2500VAC
	Between contact coils	2500VAC	2500VAC
Mechanical Endurance		2X10 ⁵ times	2X10 ⁵ times
Coil Voltage		12V,24V	12V,24V
Coil power consumption		5.5w	5.5w
Load extraction method		Internal thread	Internal thread and screw
Coil lead out method		lead wire	lead wire
Weight		About 180g	About 180g
Vibrate		10Hz-500Hz 49m/s ²	10Hz-500Hz 49m/s ²
Humidity		5%-85%RH	5%-85%RH
Humidity range		-40°C~+85°C	-40°C~+85°C
External dimensions (mm)		55.2X39.6X57.8	55.2X39.6X57.8

Technical Specifications

Product model	STE3-150	STE3-200	STE3-250	
Contact form	1H	1H	1H	
Auxiliary contact	NO	NO	NO,	
Contact polarit	Having polarity	Having polarity	Having polarity	
Contact resistance	≤1.5mΩat 150A)	≤1.5mΩ(at 200A)	≤1.5mΩ(at 250A)	
Operating voltage	≤75%Un	≤75%Un	≤75%Un	
Maximum breaking current	150A	200A	200A	
Electrical endurance	10-1000V	10-1000V	10-1000V	
Maximum breaking current	1600A(300VDC)	2000A(300VDC)	2000A(300VDC)	
Electrical endurance	50 times(1000V,150A)	30 times(1000V,150A)	15 times(1000V,150A)	
Current carrying	150A:Continuous for 400A:10min 800A:10s	200A:Continuous for 400A:10min 800A:10s	250A:Continuous for 400A:10min 800A:10s	
Dielectric withstand voltage	Between open contacts	4000VAC	4000VAC	4000VAC
	Between contact coils	4000VAC	4000VAC	4000VAC
Mechanical Endurance	2X10 ⁵ times	2X10 ⁵ times	2X10 ⁵ times	
Coil Voltage	12V,24V	12V,24V	12V,24V	
Coil power consumption	Start 45w,maintain 2.8W	Start 45w,maintain 2.8W	Start 45w,maintain 2.8W	
Load extraction method	External thread	External thread	External thread	
Coil lead out method	lead wire	lead wire	lead wire	
Weight	440g	440g	440g	
Vibrate	10Hz ~ 500Hz 49m/s ²	10Hz ~ 500Hz 49m/s ²	10Hz ~ 500Hz 49m/s ²	
Humidity	5% ~ 85%RH	5% ~ 85%RH	5% ~ 85%RH	
Humidity range	-40°C-85°C	-40°C-85°C	-40°C-85°C	
External dimensions (mm)	80.3×66×64.3	80.3×66×64.3	80.3×66×64.3	

Note: 1.The above parameters are all initial values,measured at room temperature of 23°C.
2. Unless otherwise specified,the electrica durabilitytests are conductedon resistiveloads with a on/off ratio of 0.6s:5.4s.

Technical Specifications

Product model	STE3-300	STE3-350	
Contact form	1H	1H	
Auxiliary contact	NO	NO	
Contact polarit	Having polarity	Having polarity	
Contact resistance	≤1.5m(at 300A)	≤1.5m(at 350A)	
Operating voltage	≤75%Un	≤75%Un	
Maximum breaking current	300A	350A	
Electrical endurance	10-1000V	10-1000V	
Maximum breaking current	2000A(300VDC)	2000A(300VDC)	
Electrical endurance	300A:Continuous for 400A:10min 600A:30s	350A:Continuous for 400A:10min 800A:10s	
Current carrying	10 times(1000V,300A)	50 times(1000V,300A)	
Dielectric withstand voltage	Between open contacts	3300VAC	3300VAC
	Between contact coils	3300VAC	3300VAC
Mechanical Endurance	2X10 ⁵ times	2X10 ⁵ times	
Coil Voltage	12V,24V	12V,24V	
Coil power consumption	Start 45w,maintain 2.8W	Start 45w,maintain 2.8W	
Load extraction method	External thread	External thread	
Coil lead out method	lead wire	lead wire	
Weight	440g	440g	
Vibrate	10Hz ~ 500Hz 49m/s ²	10Hz ~ 500Hz 49m/s ²	
Humidity	5% ~ 85%RH	5% ~ 85%RH	
Humidity range	-40°C-85°C	-40°C-85°C	
External dimensions (mm)	80.3×66×64.3	80.3×66×64.3	

Note: 1.The above parameters are all initial values,measured at room temperature of 23°C.
2. Unless otherwise specified,the electrica durabilitytests are conductedon resistiveloads with a on/off ratio of 0.6s:5.4s.

When the contactor is used in the changing circuit, a pre charging circuit should be added to keep the impulse current below the rated load current

As shown in the figure, first close the main negative contactor, then close the pre charging contactor, and finally close the main positive contactor. If there is no pre charging circuit, transient high current will be generated at the moment of the main contactor closing, which may cause the main positive contactor to stick. Please be careful.

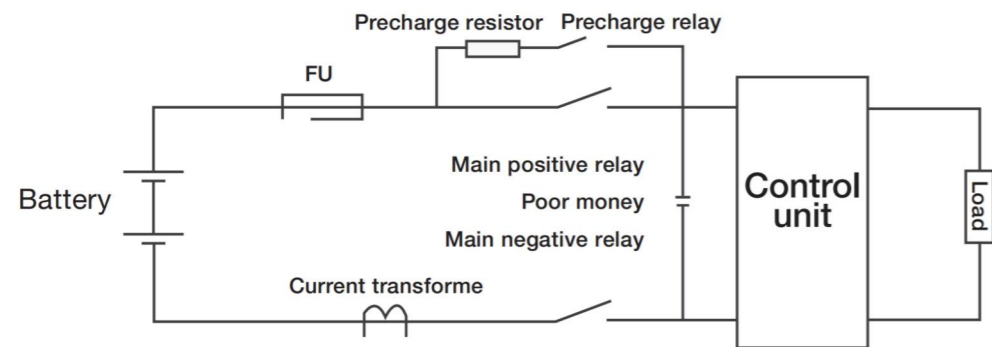

The rated values in the contact parameters are all values for resistive loads. When using an inductive load (Lload) with $L/R > 1ms$, please install surge absorbing elements in parallel at both ends of the inductive load. Without taking measures, it may cause a decrease in electrical lifespan and result in poor continuity.

The on/off reliability of the product may change under small loads due to environmental conditions and on/off frequency, so it needs to be confirmed under actual loads.

This contactor is a DC high-voltage opening and closing device. In the final fault state, there may be a situation where it cannot be turned on or off. Therefore, please do not use it beyond the capacity and frequency ranges specified in this manual. If it has reached the point where it cannot be connected or disconnected, it may lead to burning. A circuit structure that can cut off the current load in emergency situations should be adopted. To ensure safety, components should be replaced regularly.

For products that do not use coil drive boards or energy-saving versions, it is recommended to install nonlinear resistors (variable resistors are recommended) to suppress the reverse electromotive force of contactor coils. If diodes are used, the release time of the contactor will be greatly prolonged, which may lead to a decrease in cutting performance. Please be careful.

When conducting action voltage tests on products that use coil drive boards and energy-saving versions, the voltage should not slowly rise. Please use a fast rising edge (step power supply method) to drive the coil of the product, otherwise the contactor will not operate. At the same time, this type of product will automatically switch off current after about 0.3 seconds of connection, and repeated on/off operations within 0.3 seconds will cause contactor failure. Please be aware.

It is strictly prohibited to place the contactor in an environment that exceeds the product temperature range ($40^{\circ}C \sim +85^{\circ}C$) for a long time.

Please avoid installing near strong magnetic fields (transformers, magnets) and heating objects.

Ensure that the main power cord is closest to the outlet of the contactor. Then install and tighten in the order of flat washers, spring washers, and nuts. Incorrect connection sequence may cause severe overheating and lead to melting of the insulation layer of the connecting cable.

Please control the tightening torque of screws in each part within the specified range below. Beyond the range, it may cause damage to the ceramic sealing chamber and thread damage. In addition, the installation direction is not restricted.

Load outlet end		Product shell installation part	
M4	screws: 2Nm ~ 3Nm	M4	screws: 2Nm ~ 3Nm
M5	screws: 3Nm ~ 4Nm	M5	screws: 3Nm ~ 4Nm
M6	screws: 6Nm ~ 8Nm	M6	screws: 6Nm ~ 8Nm
M8	screws: 8Nm ~ 10Nm		

Please avoid sticking foreign objects such as grease on the lead out end; Please use the following specifications of connecting wires, otherwise it may cause abnormal heating of the lead out section

Current/A	Nominal cross-sectional area of conductor/mm ²
10	≥1.5
20	≥4
30	≥6
40	≥10
50	≥16
60	≥16
100	≥35
150	≥70
200	≥95
250	≥150
300	≥185
350	≥240
400	≥300
500	≥370
600	≥480
800	≥600

The suction voltage and release voltage will change with the ambient temperature and usage conditions, so please pay attention!

If the coil and contacts are continuously energized using the rated voltage (current) and then cut off, and immediately re-energized, this contactor will experience an increase in coil resistance due to the temperature rise of the coil, resulting in an increase in the suction voltage and exceeding the rated suction voltage. At this time, please take the following measures to reduce the load current, limit the power on time, and apply a coil voltage that exceeds the rated voltage of the coil (quick start).

When opening and closing without load, the contact resistance may increase, so please be careful!

This product contains resin, so please do not use it in places or environments where gasoline, diluents, alcohol lamps, organic solvents, and strong alkaline substances such as ammonia and sodium hydroxide may be attached.

Please be careful not to attach grease or foreign objects to the load terminals, otherwise it may cause abnormal heating of the load terminals.