

CHAC

CQM6 Series Molded Case Circuit Breaker

PRODUCT CATALOG



ZHEJIANG CHUANGQI ELECTRIC CO.,LTD.

- WenzhouBase
No.18,ShahongRoad,BeibaixiangTown,YueqingCity,Wenzhou,ZhejiangProvince,China
- JiaxingBase
No.61,ZhengyangWestRoad,XiuzhouDistrict,Jiaxing,ZhejiangProvince,China
- 0577-27878806
- marketing@chac-en.com
- www.chac-electric.com



LINKEDIN



WEBSITE

V2026.03-CHAC-MKT

CQM6 Series

Molded case circuit breaker



Product Features

- Core Protection: Provides essential protection against overloads and short-circuits for distribution systems and motor circuits.
- Current Range: Comprehensive coverage from 10A up to 1250A.
- Compact Design: Features a miniaturized and unified footprint for easy panel integration and space savings.
- Accessory Flexibility: Supports a wide range of accessories (shunt trips, auxiliaries, etc.) for customized control and monitoring.

Compliance

- Meets international and regional standards including

IEC/EN 60947-1(General Rules)	GB/T 14048.1
IEC/EN 60947-2(Circuit-Breakers)	GB/T 14048.2
IEC/EN 60947-3(Switchgear)	GB/T 14048.3
IEC/EN 60947-4(Contactors & Motor-Starters)	GB/T 14048.4

Accessory Voltage		Motorized operating voltage		Installation	Whether to install a terminal block	
Q1		D1		Q	2	
Undervoltage detent Q1:AC220V Q2:AC240V Q3:AC380V Q4:AC415V	Shunt release F1:AC220V F2:AC380V F3:DC110V F4:DC24V	Auxiliary alarm J1:AC125V J2:AC250V J3:DC125V J4:DC24V	DC1 Electrical Operation D1:AC220V D2:AC230V D3:AC380V D4:AC400V	DC3 Electrical Operation D5:AC230V D6:AC110V D7:DC220 D8:DC110 D9:AC110-240V D10:DC100-220V	Q:Front of plate H:Rear of plate C:Inserted	1:Noinstallation 2:Installation
Note:When motorized operation is selected,please refer to the external accessories for the two voltages applicable for motorized operation.						

Accessory List

Model number	CQM6-125	CQM6-160	CQM6-250	CQM6-630	CQM6-800	CQM6-1250
Breaking capacity	C,S	C,S,M	C,S,M	S,M,H	S,M,H	S,M,H
Number of poles	2,3,4	3,4	2,3,4	3,4	3,4	3,4
Accessory code	Accessory description					
208、308	Alarm Switch					
210、310	Shunt Release					
220、320	Auxiliary Switch					
230、330	Undervoltage Release					
240、340	Shunt Release and Auxiliary Switch					
240、250	Shunt Release and Undervoltage Release					
260、360	Two Auxiliary Switches					
270、370	Auxiliary Switch and Undervoltage Release					
218、318	Shunt Release and Alarm Switch					
228、328	Auxiliary Switch and Alarm Switch					
238、338	Undervoltage Release and Alarm Switch					
248、348	Shunt Release, Auxiliary Switch and Alarm Switch					
268、368	Two Auxiliary Switches and Alarm Switch					
278、378	Auxiliary Switch, Undervoltage Release and Alarm					
280、380	Two Auxiliary Switches and Shunt Release					

Selection Guide

CQM6 - 125 C P / 4 300 - 125A 2 A Q1 D1 Q 2

Product code	Shell frame grade	Breaking capacity					Operating method	Operating method
		C	S	M	H			
CQM6	125	C	S	M	H	P	4	
Molded case circuit breaker	125	125	15/8	25/18	/	P:Motorized operation Z:Turning handle W:Direct operation	2-pole 3-pole 4-pole	
	160	160	25/18	35/25	50/35			
	250	250	25/18	35/25	50/35			
	630	630	/	35/25	50/35			70/50
	800	800	/	35/25	50/35			70/50
	1250	1250	/	35/25	50/35	70/50		

Decoupler method and internal accessories	Rated current A	Function	Optional code for four-pole products
The first digit indicates the type of detent 2:Instantaneous detent only 3-Duplicate detent Note:The last two digits are the accessory designator(see accessory table).	300	125A	2
		125	10,16,20,32,40,50,63,80,100,125
		160	10,16,20,32,40,50,63,80,100,125,140,160
		250	100,125,140,160,180,200,225,250
		630	250,315,350,400,500,630
		800	500,630,700,800
	1250	800,1000,1250	
		1:For power distribution 2:For motor protection	A:N-pole is unprotected and cannot be combined B:N-pole is unprotected and can be combined C:N-pole is protected and can be combined D:N-pole is protected and cannot be combined

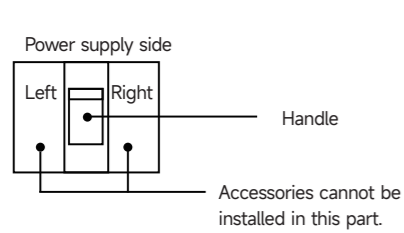

- Alarm switch
- Auxiliary switch
- Undervoltage release
- Shunt trip

- Our company can provide three new products for customers to choose from, namely the right-side auxiliary switch, the left-side shunt trip device, and the left-side undervoltage release device.
- For the specifications of 220, 320, 240, 340, 270 and 370, the auxiliary switch can provide two pairs of switches. Please specify this when placing an order.
- For the 250 and 350 specifications, the shunt trip device and undervoltage release for models 400 and above can only be installed on 3-pole circuit breakers.

Main Technical Parameters

Model number	CQM6-125			CQM6-160			
Rated current of frame level Inm(A)	125			160			
Number of poles	2, 3, 4			3, 4			
Rated current In(A), at 40°C, 50°C, 55°C	10, 16, 20, 25, 32, 40, 50, 63, 80, 100, 125			10, 16, 20, 25, 32, 40, 50, 63, 80, 100, 125, 140, 160			
Rated operating voltage Ue(V), AC 50/60Hz	400/415			400/415			
Rated insulation voltage Ui (V)	800			800			
Rated impulse withstand voltage Uimp(KV)	8			8			
Breaking capacity designation	C	S		C	S	M	
Short-circuit breaking capacity Icu/Ics(kA)	AC400/415V 15/8 25/18			25/18	35/25	50/35	
Selectivity category	A	A		A	A	A	
Number of operating cycles (cycle)	ON 6000			6000			
	OFF 10000			10000			
Trip mechanisms and protection types	Magnetic trip	Power distribution protection	●	●	●	●	
		Motor protection	●	●	●	●	
	Thermal-magnetic trip	Power distribution protection	●	●	●	●	
		Motor protection	●	●	●	●	
Auxiliary contacts		●	●	●	●	●	
Alarm contacts		●	●	●	●	●	
Shunt disconnect		●	●	●	●	●	
Undervoltage detent		●	●	●	●	●	
Manual operating mechanism		●	●	●	●	●	
Motorized operating mechanism		●	●	●	●	●	
Backplane wiring		●	●	●	●	●	
Inserted		●	●	●	●	●	
Coupling plate		●	●	●	●	●	
Partition between phases		●	●	●	●	●	
Derivative products	Dedicated for prepayment electric meters		●	●	●	●	
	Overload alarm without trip		-	-	-	●	●
Overall dimensions (mm) (a-b-c-ca)		3 P	75-130-68-92			90-155-70-94	90-155-84-109
		4 P	100-130-68-92			120-155-70-94	120-155-84-109

Note: ● for optional accessories; "-" for no optional accessories.

Main Technical Parameters

Model number	CQM6-250			CQM6-630		
Rated current of frame level Inm(A)	250			630		
Number of poles	2, 3, 4			3, 4		
Rated current In(A), at 40°C, 50°C, 55°C	125, 140, 160, 180, 200, 225, 250			250, 315, 350, 400, 500, 630		
Rated operating voltage Ue(V), AC 50/60Hz	400/415			400/415		
Rated insulation voltage Ui (V)	800			800		
Rated impulse withstand voltage Uimp(KV)	8			8		
Breaking capacity designation	C	S	M	S	M	H
Short-circuit breaking capacity Icu/Ics(kA)	AC400/415V 25/18 35/25 50/35			35/25	50/35	70/50
Selectivity category	A	A	A	A	A	A
Number of operating cycles (cycle)	ON 6000			3000		
	OFF 10000			8000		
Trip mechanisms and protection types	Magnetic trip	Power distribution protection	●	●	●	●
		Motor protection	●	●	●	●
	Thermal-magnetic trip	Power distribution protection	●	●	●	●
		Motor protection	●	●	●	●
Auxiliary contacts		●	●	●	●	●
Alarm contacts		●	●	●	●	●
Shunt disconnect		●	●	●	●	●
Undervoltage detent		●	●	●	●	●
Manual operating mechanism		●	●	●	●	●
Motorized operating mechanism		●	●	●	●	●
Backplane wiring		●	●	●	●	●
Inserted		●	●	●	●	●
Coupling plate		●	●	●	●	●
Partition between phases		●	●	●	●	●
Derivative products	Dedicated for prepayment electric meters		●	●	●	●
	Overload alarm without trip		●	●	●	●
Overall dimensions (mm) (a-b-c-ca)		3 P	105-165-70-96	105-165-93-120	140-257-105-155	
		4 P	140-165-70-96	140-165-93-120	185-257-105-155	

Note: ● for optional accessories; "-" for no optional accessories.

Main Technical Parameters

Model number		CQM6-800			CQM6-1250		
Rated current of frame level Inm(A)		800			1250		
Number of poles		3,4			3,4		
Rated current In(A),at 40°C,50°C,55°C		500, 630, 700, 800			1000, 1250		
Rated operating voltage Ue(V),AC 50/60Hz		400/415			400/415		
Rated insulation voltage Ui (V)		800			800		
Rated impulse withstand voltage Uimp(KV)		8			8		
Breaking capacity designation		S	M	H	S	M	H
Short-circuit breaking capacity Icu/Ics(kA) AC400/415V		35/25	50/35	70/50	25/18	35/25	70/50
Selectivity category		A	A	A	A	A	A
Number of operating cycles (cycle)		ON 3000			1000		
		OFF 8000			3000		
Trip mechanisms and protection types	Magnetic trip	Power distribution protection	●	●	●	●	●
		Motor protection	●	●	●	●	●
	Thermal-magnetic trip	Power distribution protection	●	●	●	●	●
		Motor protection	●	●	●	●	●
Accessory	Auxiliary contacts		●	●	●	●	●
	Alarm contacts		●	●	●	●	●
	Shunt disconnect		●	●	●	●	●
	Undervoltage detent		●	●	●	●	●
	Manual operating mechanism		●	●	●	●	●
	Motorized operating mechanism		●	●	●	●	●
	Backplane wiring		●	●	●	●	●
	Inserted		●	●	●	●	●
	Coupling plate		●	●	●	●	●
	Partition between phases		●	●	●	●	●
Derivative products	Dedicated for prepayment electric meters		●	●	●	●	●
	Overload alarm without trip		●	●	●	●	●
Overall dimensions (mm) (a-b-c-ca)		3 P	210-275-105-155		210-275-105-155		
		4 P	280-275-105-155		280-275-105-155		

Note: ● for optional accessories; "-" for no optional accessories.

Operating Characteristics

1. The inverse time operating characteristics of power distribution circuit breakers when all poles are energized simultaneously at an ambient air temperature of +40°C (with no humidity compensation) are shown in the following table:

Test current designation	Setting current multiple	Conventional time	Initial state
		$I_n \leq 63$ $63 < I_n$	
Conventional non-tripping current	1.05	$\geq 1h$ $\geq 2h$	Cool state
Conventional tripping current	1.30	$< 1h$ $< 2h$	Hot state

2. The inverse time action characteristics of circuit breakers for motor protection without humidity compensation when all poles are energized simultaneously at an ambient air temperature of +40°C are shown in the following table.

Test current designation	Setting current multiple	Conventional time	Initial state
		$I_n \leq 800$	
Conventional non-tripping current	1.0	$\geq 2h$	Cool state
Conventional tripping current	1.2	$< 2h$	Hot state

3. Action characteristics under short-circuit condition: The short-circuit current setting value of the instantaneous tripper of the circuit breaker for power distribution is $10I_n$.
The short-circuit current setting value of the instantaneous tripper of the circuit breaker for motor protection is $12I_n$.
The accuracy of the short-circuit current setting value of the instantaneous tripper is 20% of the short-circuit current setting value.

CQM6-125 Operating Characteristic Curve

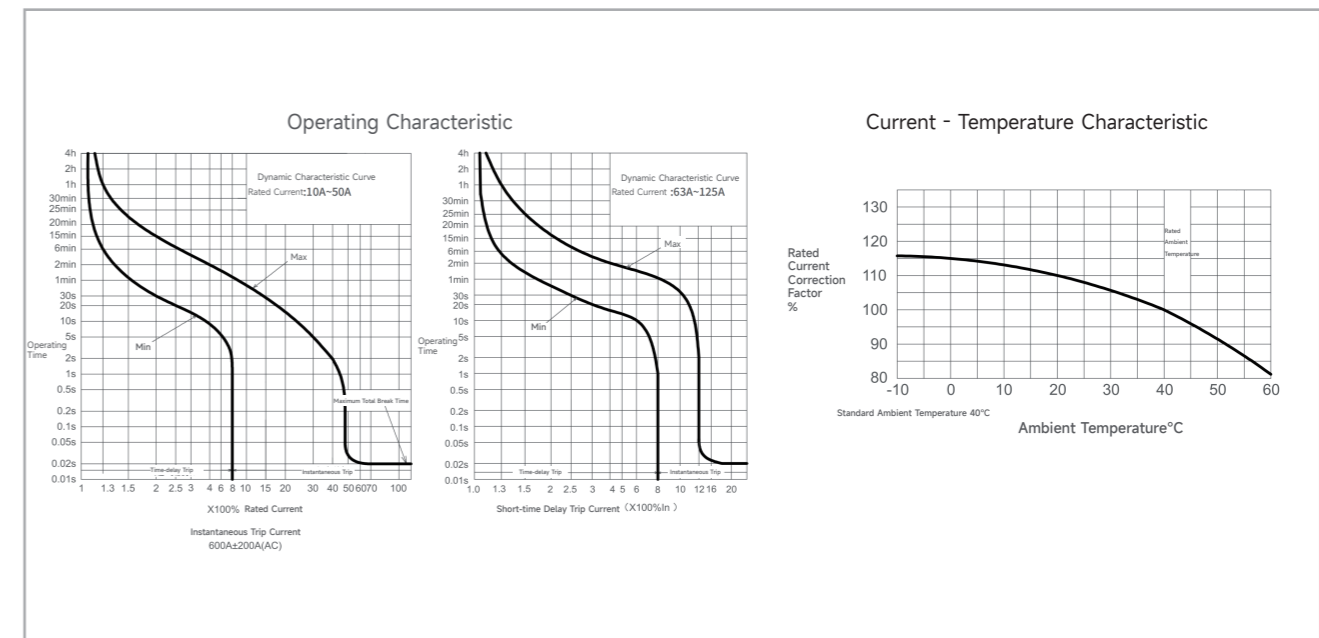

CQM6-160 Operating Characteristic Curve

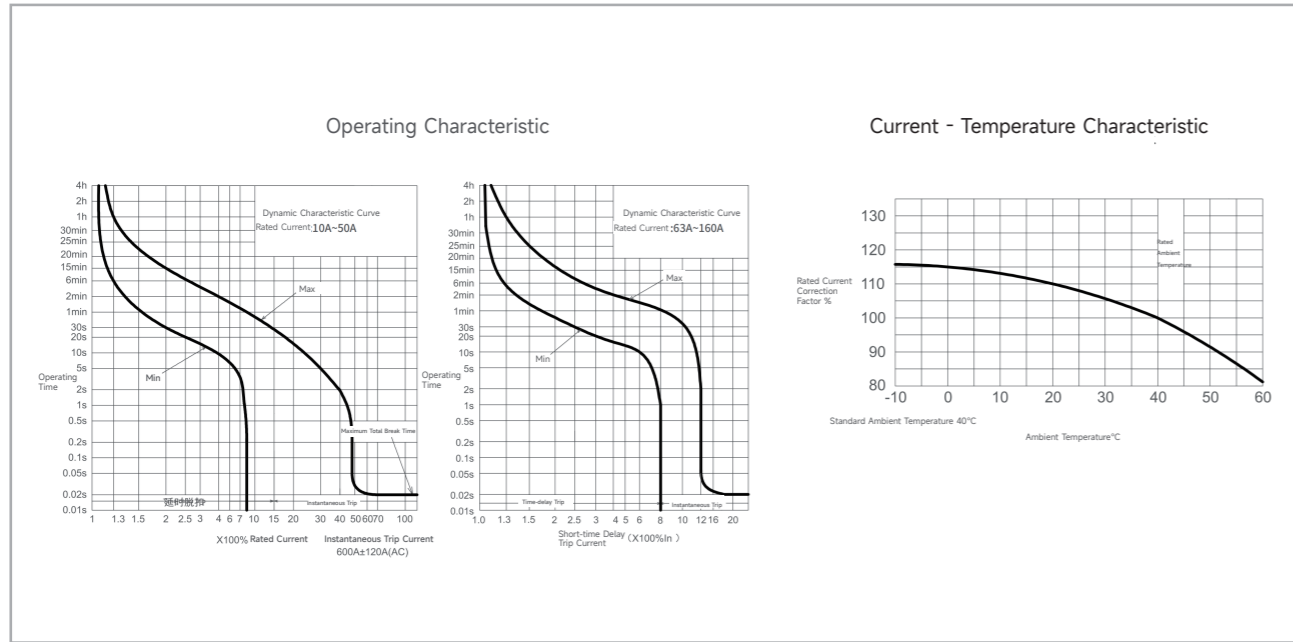

CQM6-630 Operating Characteristic Curve

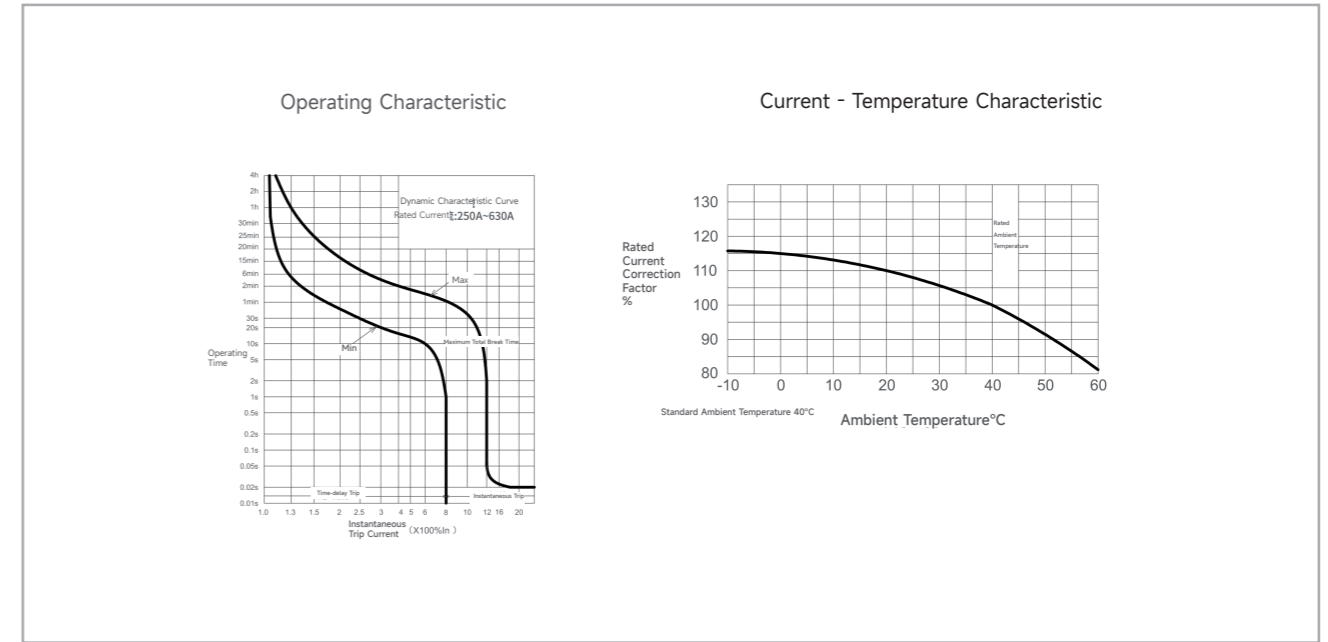

CQM6-250 Operating Characteristic Curve

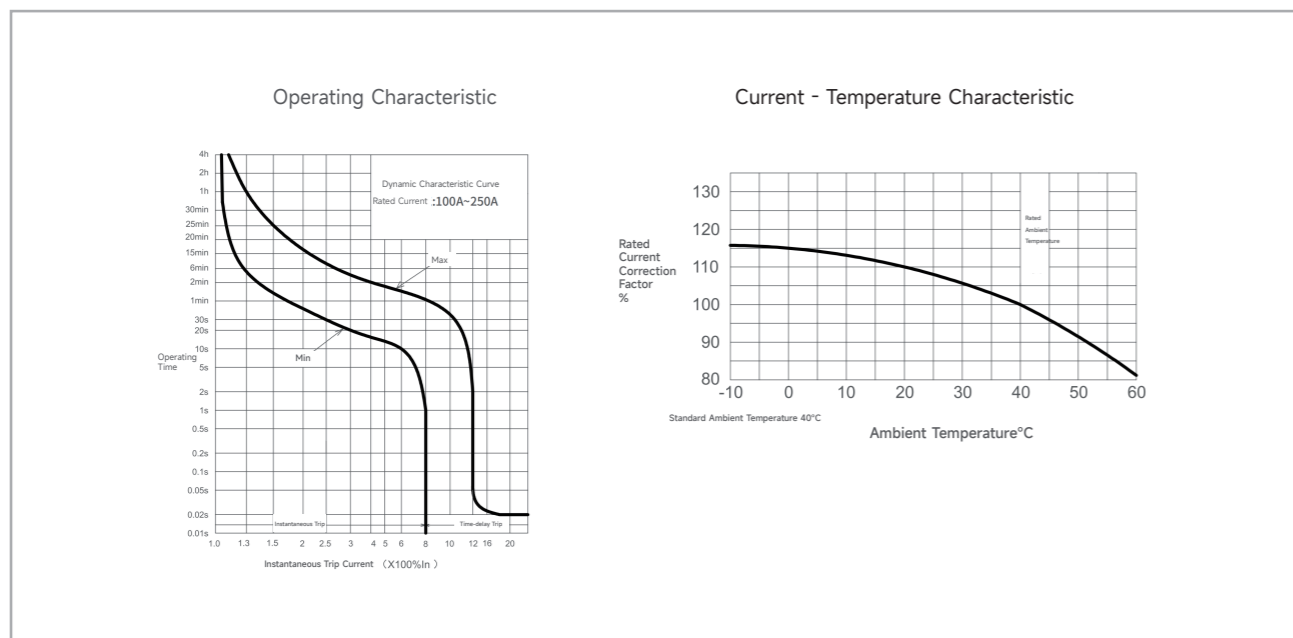

CQM6-800 Operating Characteristic Curve

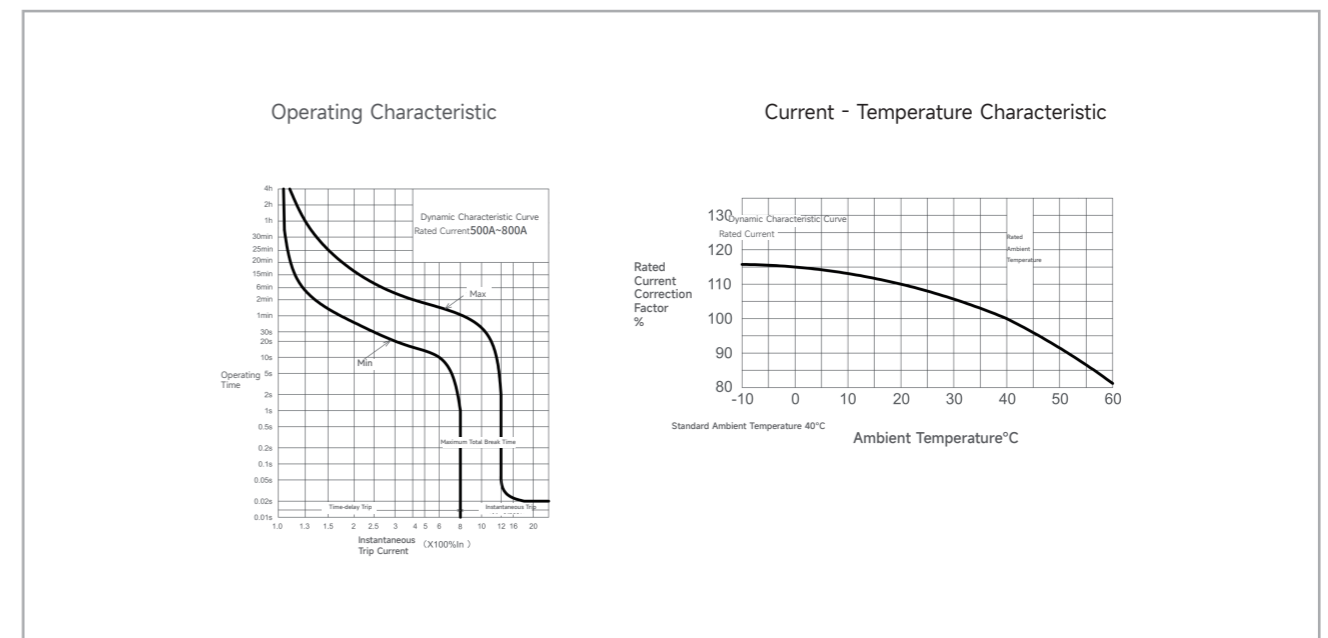

CQM6-1250 Operating Characteristic Curve

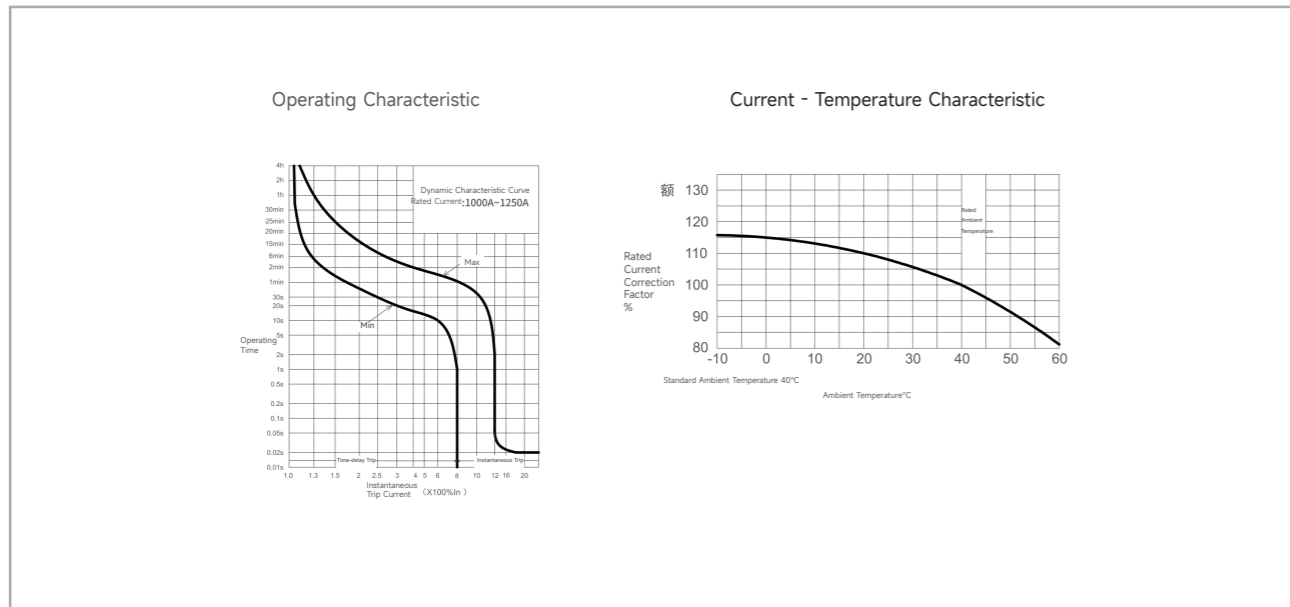

Outline and Installation Dimensions(mm)

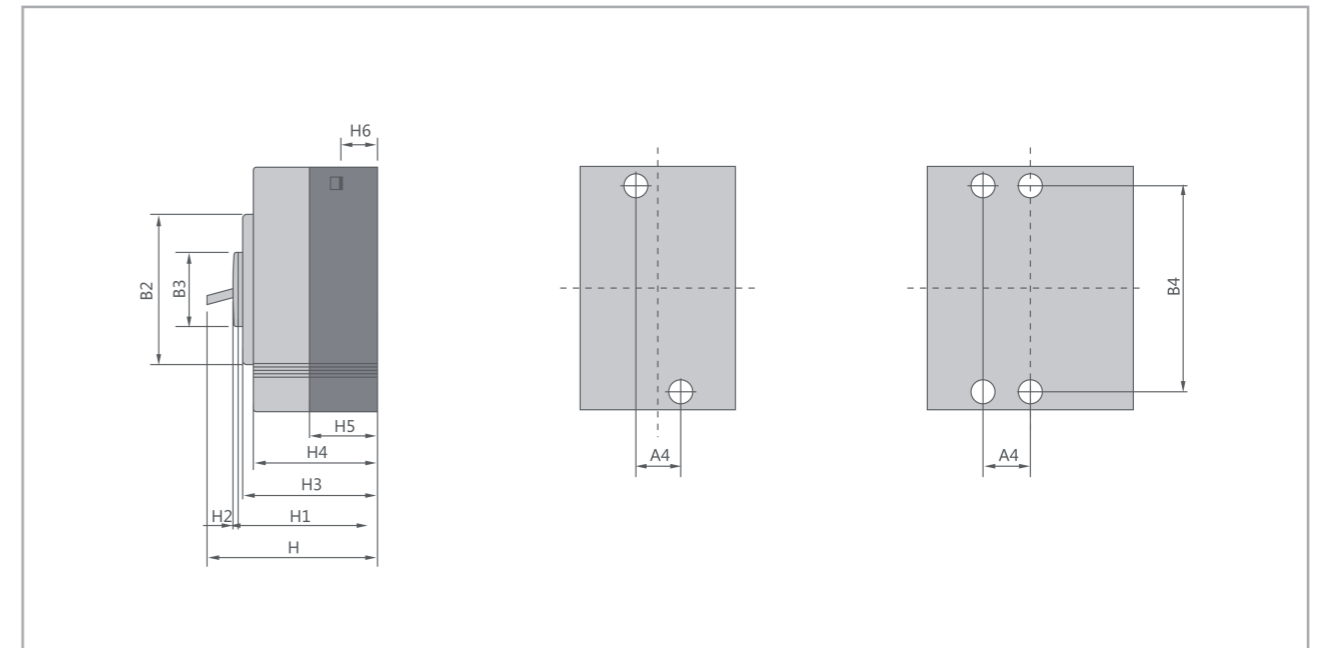

Outline and Installation Dimensions(mm)

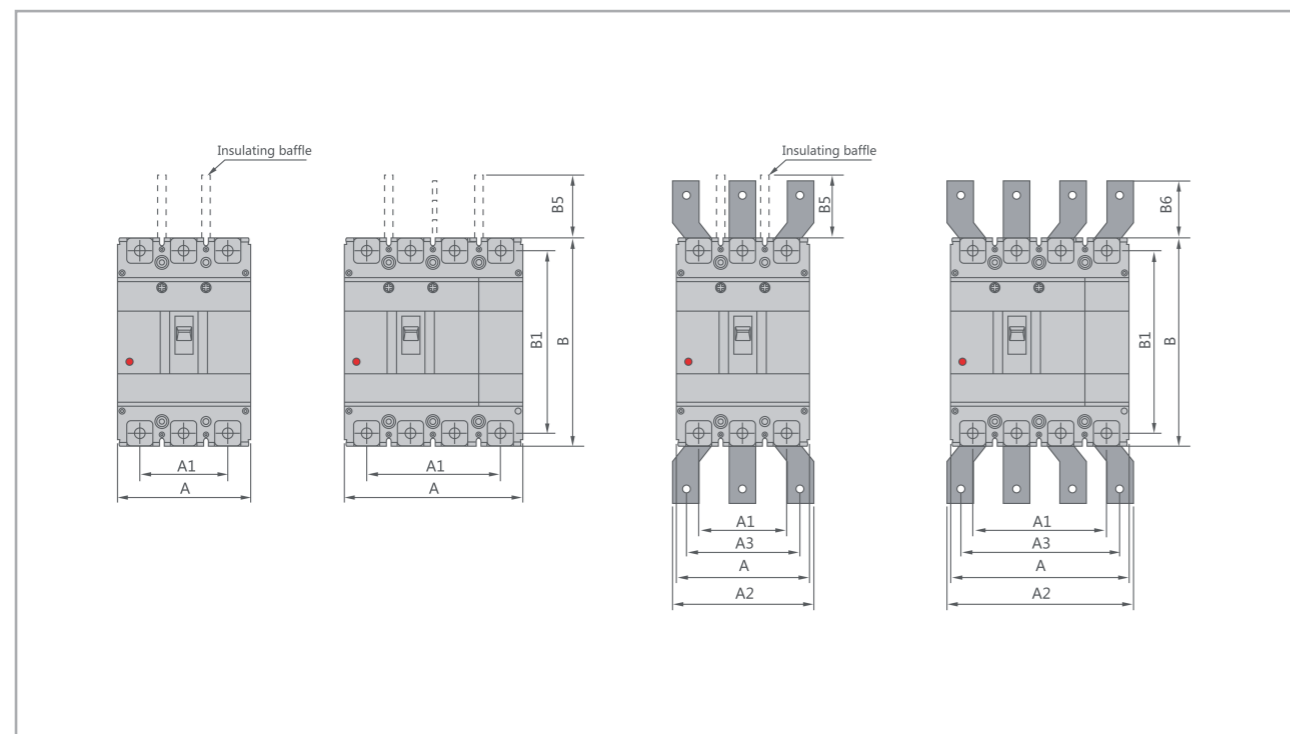

Molded case circuit breaker	Overall dimension																		Installation dimensions		Boit			
	A		A1		A2		A3		B	B1	B2	B3	B5	B6	H	H1	H2	H3	H4	H5		H6	A4	B4
	3P	4P	3P	4P	3P	4P	3P	4P																
CQM6-125CS	75	100	50	75	-	-	-	-	130	114	85	50	50	-	92	72	4	68	61	41	24	25	111	M8/M6
CQM6-160CS	90	120	60	90	-	-	-	-	155	134	103	50	50	-	94	72	4	70	61	41	24	30	132	M8
CQM6-160M	90	120	60	90	-	-	-	-	155	134	103	50	50	-	109	83	4	83	76	24.5	24.5	30	132	M8
CQM6-250CS	105	140	70	105	-	-	-	-	165	144	103	50	100	-	96	72	4	70	61	46	24	35	126	M8
CQM6-250M	105	140	70	105	-	-	-	-	165	144	102	50	110	-	120	95	4	91	84	22.5	24	35	126	M8
CQM6-630SMH	140	185	88	132	140	196	112	168	257	230	179	90	110	42	155	107	5	105	97	64	35	44	194	M10
CQM6-800SMH	210	280	140	210	180	250	140	210	275	243	192	90	110	87	155	107	5	104	97	65	24	70	242.5	M12
CQM6-1250SMH	210	280	140	210	180	250	140	210	275	243	192	90	110	87	155	107	5	104	97	65	24	70	242.5	M10*2

CQM6L Series

Residual current operated circuit breakers



Product Features

- **Integrated Safety:** Combines the overcurrent protection of a standard MCCB with earth leakage (RCCB) functionality in a single device for enhanced safety.
- **Seamless Compatibility:** Shares the same compact dimensions and accessory platform as the standard CQM6 series, allowing for easy upgrades.
- **Selective Tripping:** Offers configurable options for the N-pole (protected/unprotected, combinable) to meet specific system grounding requirements.
- **High Reliability:** Maintains the proven environmental resilience and mechanical durability of the CQM6 product line.

Compliance

- Meets international and regional standards including

IEC/EN 60947-1(General Rules)	GB/T 14048.1
IEC/EN 60947-2(Circuit-Breakers)	GB/T 14048.2
IEC/EN 60947-3(Switchgear)	GB/T 14048.3
IEC/EN 60947-4(Contactors & Motor-Starters)	GB/T 14048.4

Decoupler method and internal accessories	Rated current A	Function	Optional code for four-pole products
300	160A	2	A
The first digit indicates the type of detent 2:Instantaneous detent only 3:Duplicate detent Note:The last two digits are the accessory designator(see accessory table).	160	10,16,20,32,40,50,63,80,100,125,140,160	1:For power distribution 2:For motor protection A:N-pole is unprotected and cannot be combined B:N-pole is unprotected and can be combined C:N-pole is protected and can be combined D:N-pole is protected and cannot be combined
	250	100,125,140,160,180,200,225,250	
	630	250,315,350,400,500,630	
	800	500,630,700,800	

Product code	Breaking capacity				
L1	Y1				
Fixed delay type	Quick three-step adjustable		Fixed delay type	Quick three-step adjustable	
L1:30	L6:200	L11:30,50,100	Y1:0.1S	Y4:0.4S	Y7:0.7S
L2:50	L7:300	L12:30,100,200	Y10:1.0S	Y13:0.45,1,2	
L3:75	L8:500	L13:30,100,500	Y2:0.2S	Y5:0.5S	Y8:0.8S
L4:100	L9:500	L14:100,300,500	Y11:1.1S	Y14:1,2,3	
L5:150	L10:1000	L15:100,300,500	Y3:0.3S	Y6:0.6S	Y9:0.9S
		L16:100,300,1000	Y12:1.2S		

Selection Guide

CQM6L - 160 S P / 4 300 - 160A 2 A L1 Y1 Q1 D1 Q 2

Product code	Shell frame grade	Breaking capacity					Operating method	Operating method
		C	S	M	H			
CQM6L	160	C					P	4
Molded case circuit breaker	160	160	25/18	35/25	/	/	P:Motorized operation Z:Turning handle W:Direct operation	3-pole 4-pole
	250	250	25/18	35/25	/	/		
	630	630	/	35/25	50/35	75/75		
	800	800	/	35/25	50/35	75/75		
	1250	1250	/	35/25	50/35	75/75		

Accessory Voltage	Motorized operating voltage		Installation	Whether to install a terminal block
Q1	D1		Q	2
Undervoltage detent Q1:AC220V Q2:AC240V Q3:AC380V Q4:AC415V	Shunt release F1:AC220V F2:AC380V F3:DC110V F4:DC24V	Auxiliary alarm J1:AC125V J2:AC250V J3:DC125V J4:DC24V	DC1 Electrical Operation D1:AC220V D2:AC230V D3:AC380V D4:AC400V DC3 Electrical Operation D5:AC230V D6:AC110V D7:DC220 D8:DC110 D9:AC110-240V D10:DC100-220V	Q:Front of plate H:Rear of plate C:Inserted 1:Noinstallation 2:Installation
Note:When motorized operation is selected,please refer to the external accessories for the two voltages applicable for motorized operation.				

Accessory List

Model number	CQM6L-160	CQM6L-250	CQM6L-630	CQM6L-800
Breaking capacity	C,S	C,S	S,M,H	S,M,H
Number of poles	4	4	3, 4	4
Accessory code				
208、308	Alarm Switch			
210、310	Shunt Release			
220、320	Auxiliary Switch			
230、330	Undervoltage Release			
240、340	Shunt Release and Auxiliary Switch			
260、360	Two Auxiliary Switches			
270、370	Auxiliary Switch and Undervoltage Release			
218、318	Shunt Release and Alarm Switch			
228、328	Auxiliary Switch and Alarm Switch			
238、338	Undervoltage Release and Alarm Switch			
248、348	Shunt Release, Auxiliary Switch and Alarm Switch			
268、368	Two Auxiliary Switches and Alarm Switch			
278、378	Auxiliary Switch, Undervoltage Release and Alarm Switch			
280、380	Two Auxiliary Switches and Shunt Release			

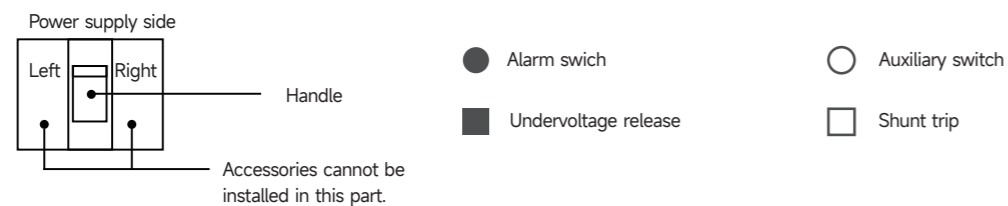

Main Technical Parameters

Model number	CQM6L-160	CQM6L-250				
Rated current of frame level Inm(A)	160	250				
Number of poles	4	4				
Rated current In(A),at 40°C,50°C,55°C	10, 16, 20, 32, 40, 50, 63, 80, 100, 125, 160	125,140,160,180,200,225,250				
Rated operating voltage Ue(V),AC 50/60Hz	400/415	400/415				
Rated insulation voltage Ui (V)	800	800				
Rated impulse withstand voltage Uimp(KV)	8	8				
Breaking capacity designation	C	S	C	S		
Short-circuit breaking capacity Icu/lcs(kA)	AC400/415V	25/18	35/25	25/18	35/25	
Selectivity category	A	A	A	A		
Number of operating cycles	ON	6000	6000			
(cycle)	OFF	10000	10000			
Trip mechanisms and protection types	Magnetic trip	Power distribution protection	●	●	●	●
		Motor protection	●	●	●	●
	Thermal-magnetic trip	Power distribution protection	●	●	●	●
		Motor protection	●	●	●	●
Accessory	Auxiliary contacts	●	●	●	●	
	Alarm contacts	●	●	●	●	
	Shunt disconnect	●	●	●	●	
	Undervoltage detent	●	●	●	●	
	Manual operating mechanism	●	●	●	●	
	Motorized operating mechanism	●	●	●	●	
	Backplane wiring	●	●	●	●	
	Inserted	●	●	●	●	
	Coupling plate	●	●	●	●	
	Partition between phases	●	●	●	●	
Derivative products	Dedicated for prepayment electric meters	●	●	●	●	
	Overload alarm without trip	●	●	●	●	
Overall dimensions (mm) (a-b-c-ca)	4 P	120-155-70-94	140-165-70-96			

Note: ● for optional accessories; “-” for no optional accessories.

Main Technical Parameters

Model number		CQM6L-630			CQM6L-800		
Rated current of frame level In(A)		630			800		
Number of poles		3, 4			4		
Rated current In(A),at 40°C,50°C,55°C		250, 315, 350, 400, 500, 630			500,630,700,800		
Rated operating voltage Ue(V),AC 50/60Hz		400/415			400/415		
Rated insulation voltage Ui (V)		800			800		
Rated impulse withstand voltage Uimp(KV)		8			8		
Breaking capacity designation		S	M	H	S	M	H
Short-circuit breaking capacity Icu/Ics(kA)		AC400/415V 35/25 50/35 75/75			35/25 50/35 75/75		
Selectivity category		A	A	A	A	A	A
Number of operating cycles (cycle)		ON 3000 OFF 8000			3000 8000		
Trip mechanisms and protection types	Magnetic trip	Power distribution protection	●	●	●	●	●
		Motor protection	●	●	●	●	●
	Thermal-magnetic trip	Power distribution protection	●	●	●	●	●
		Motor protection	●	●	●	●	●
Accessory		Auxiliary contacts	●	●	●	●	●
		Alarm contacts	●	●	●	●	●
		Shunt disconnect	●	●	●	●	●
		Undervoltage detent	●	●	●	●	●
		Manual operating mechanism	●	●	●	●	●
		Motorized operating mechanism	●	●	●	●	●
		Backplane wiring	●	●	●	●	●
		Inserted	●	●	●	●	●
		Coupling plate	●	●	●	●	●
		Partition between phases	●	●	●	●	●
Derivative products		Dedicated for prepayment electric meters	●	●	●	●	●
		Overload alarm without trip	●	●	●	●	●
Overall dimensions (mm) (a-b-c-ca)			4 P	185-257-105-155	280-275-105-155		

Note: ● for optional accessories; “-” for no optional accessories.

Operating Characteristics

1. The inverse time operating characteristics of power distribution circuit breakers when all poles are energized simultaneously at an ambient air temperature of +40°C (with no humidity compensation) are shown in the following table:

Test current designation	Setting current multiple	Conventional time	Initial state
		In ≤ 63 In > 63	
Conventional non-tripping current	1.05	≥ 1h ≥ 2h	Cool state
Conventional tripping current	1.30	< 1h < 2h	Hot state

2. The inverse time action characteristics of circuit breakers for motor protection without humidity compensation when all poles are energized simultaneously at an ambient air temperature of +40°C are shown in the following table.

Test current designation	Setting current multiple	Conventional time	Initial state
		In ≤ 800	
Conventional non-tripping current	1.0	≥ 2h	Cool state
Conventional tripping current	1.2	< 2h	Hot state

3. Action characteristics under short-circuit condition: The short-circuit current setting value of the instantaneous tripper of the circuit breaker for power distribution is 10In. The short-circuit current setting value of the instantaneous tripper of the circuit breaker for motor protection is 12In. The accuracy of the short-circuit current setting value of the instantaneous tripper is 20% of the short-circuit current setting value.

CQM6L-125 Operating Characteristic Curve

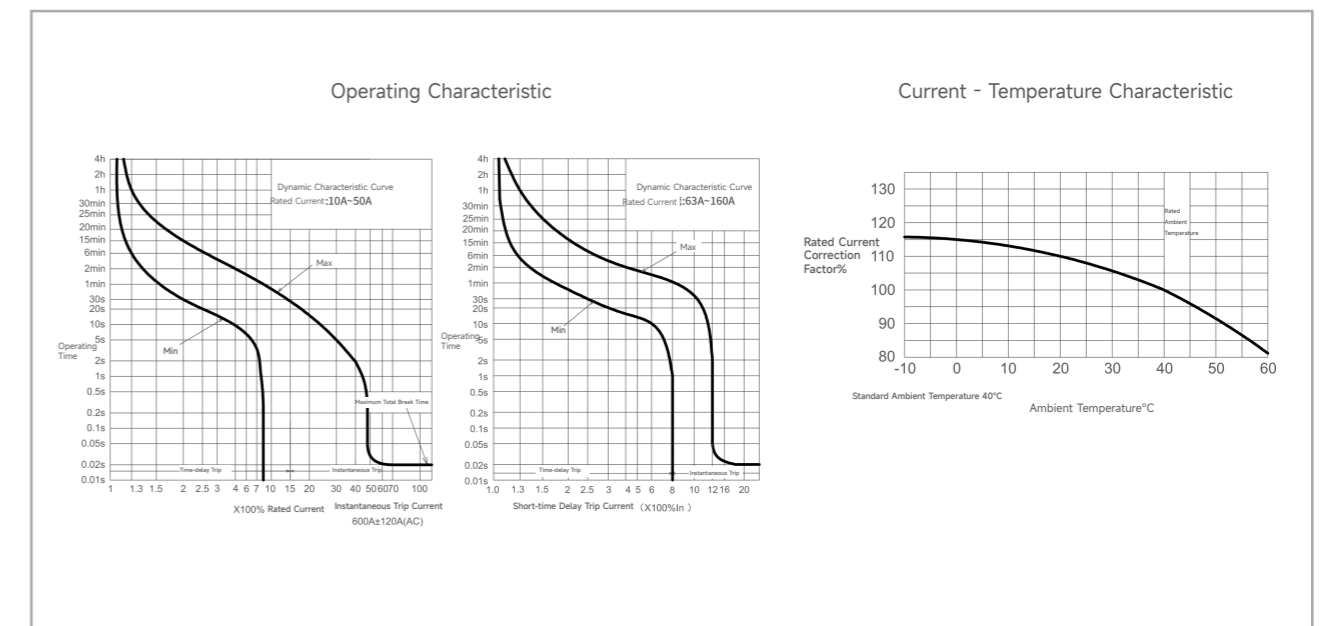

CQM6L-250 Operating Characteristic Curve

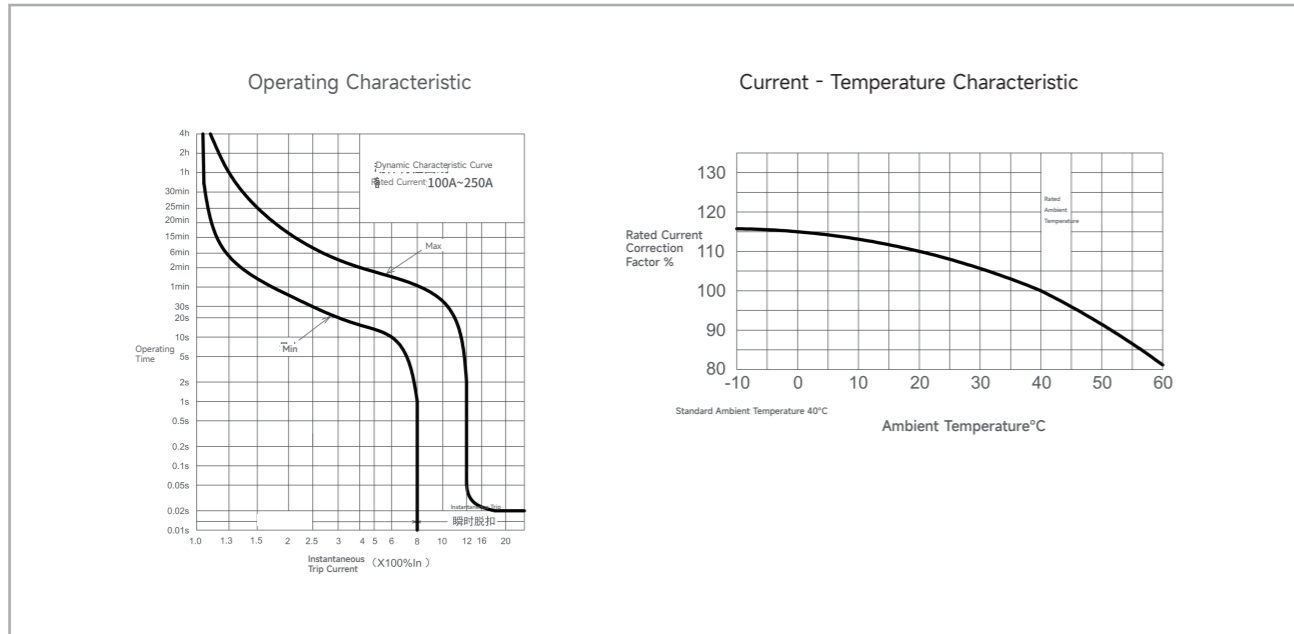

CQM6L-800 Operating Characteristic Curve

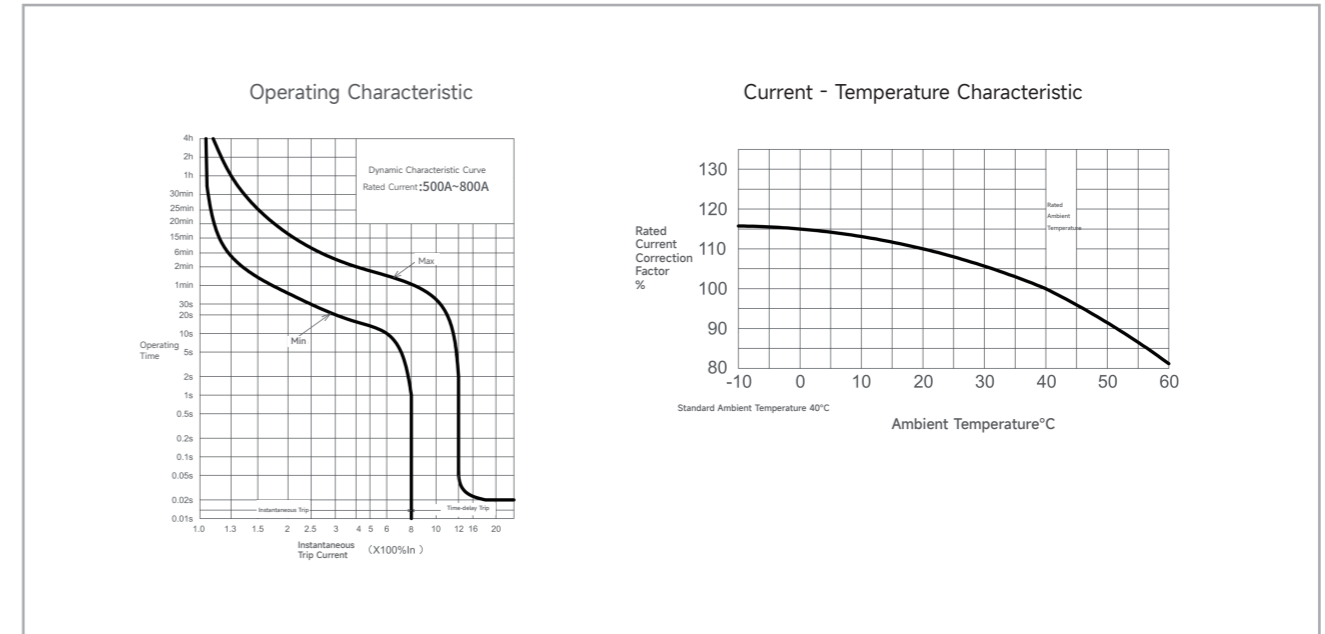

CQM6L-630 Operating Characteristic Curve

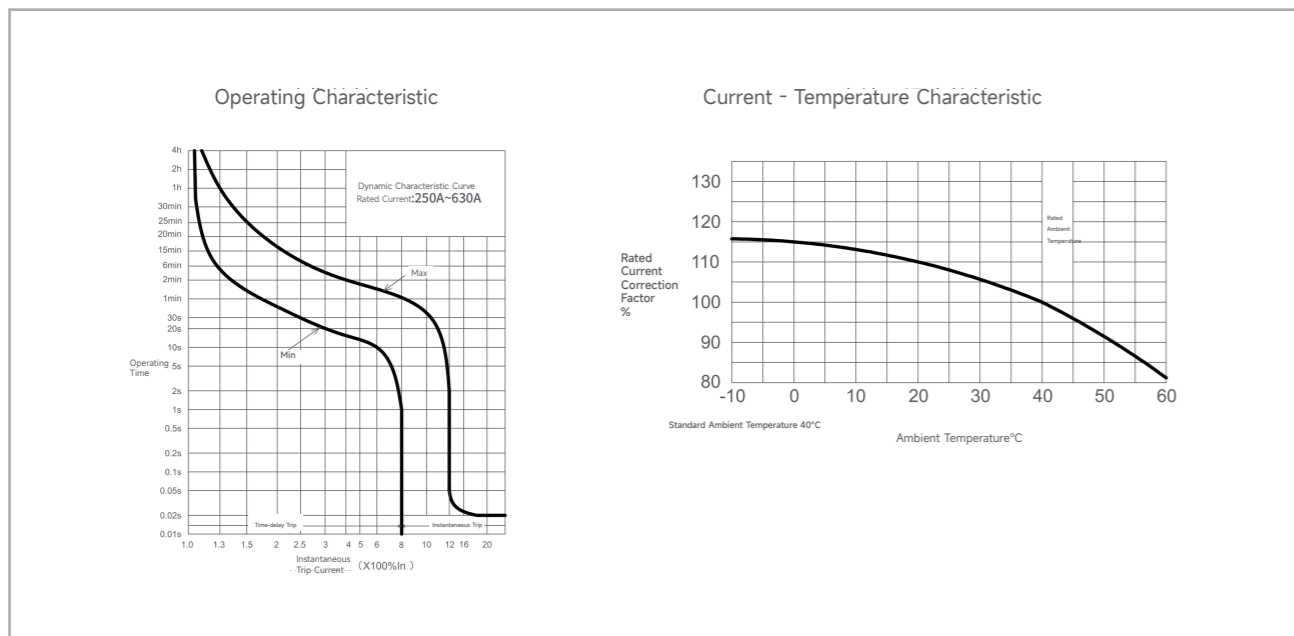

CQM6L-1250 Operating Characteristic Curve

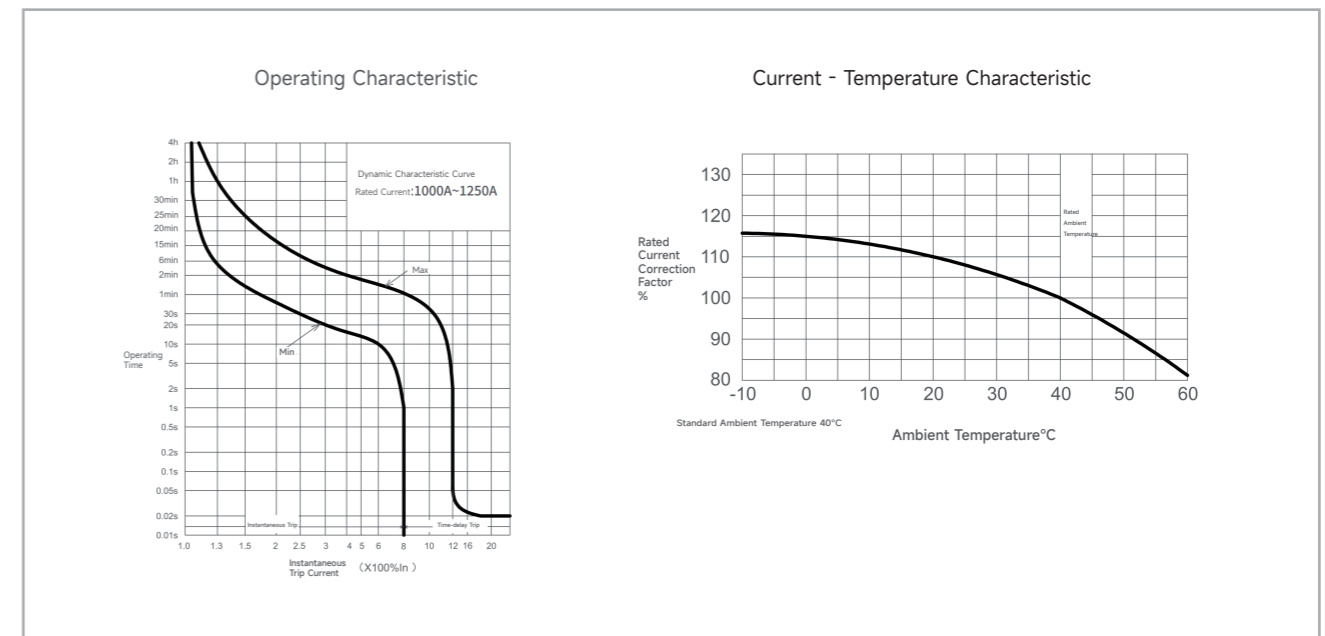

Outline and Installation Dimensions(mm)

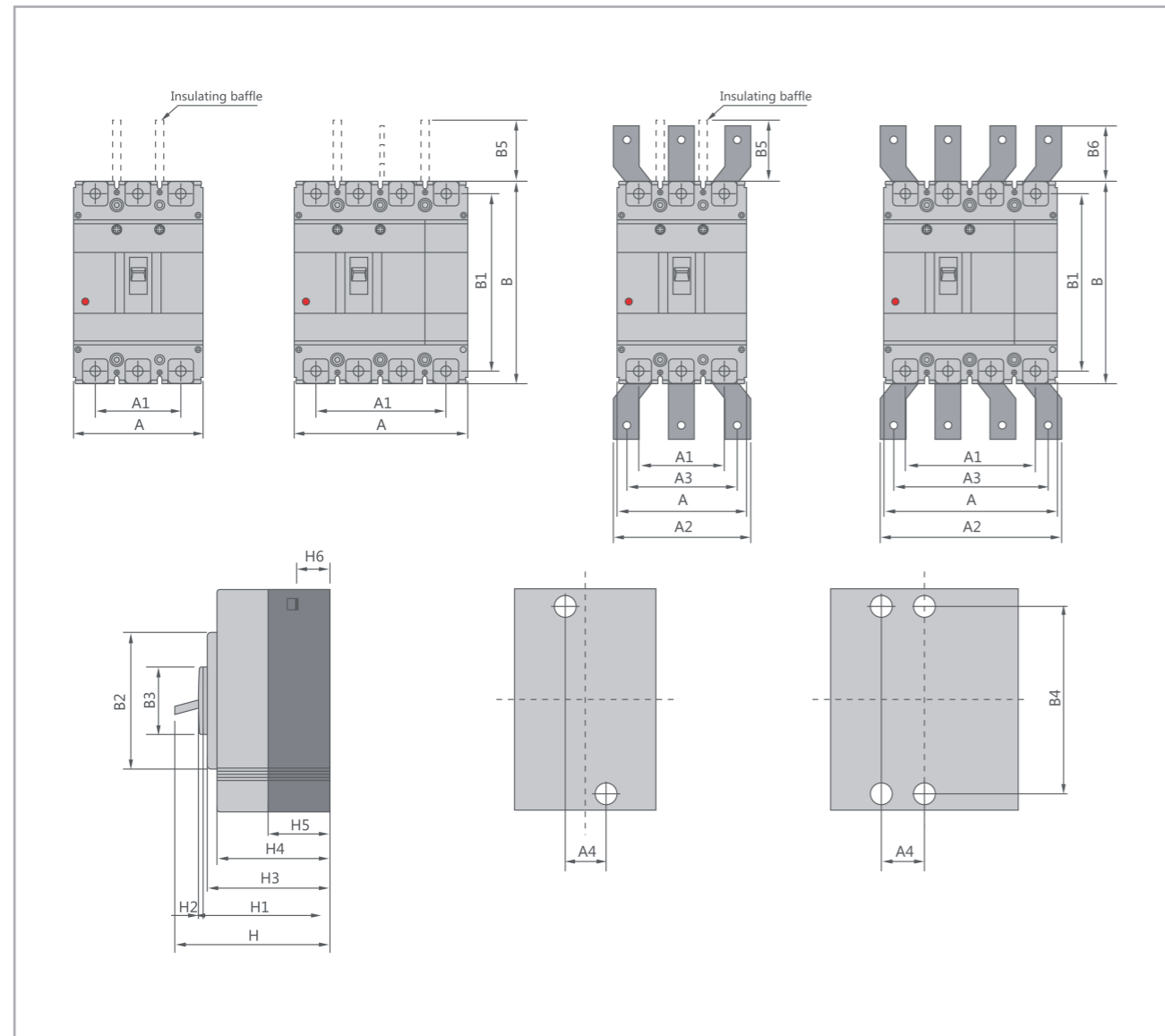

Molded case circuit breaker	Overall dimension																		Installation dimensions		Boit			
	A		A1		A2		A3		B	B1	B2	B3	B5	B6	H	H1	H2	H3	H4	H5		H6	A4	B4
	3P	4P	3P	4P	3P	4P	3P	4P																
CQM6L-160	-	120	-	90	-	-	-	-	155	134	103	50	50	-	94	72	4	70	61	41	24	30	132	M8
CQM6L-250	-	140	-	105	-	-	-	-	165	144	103	50	100	-	96	72	4	70	61	46	24	35	126	M8
CQM6L-630	-	185	-	132	-	196	-	168	257	230	179	90	110	42	155	107	5	105	97	64	35	44	194	M10
CQM6L-800	-	280	-	210	-	250	-	210	275	243	192	90	110	87	155	107	5	104	97	65	24	70	242.5	M12

CQM6T/A, RT Series
Molded case circuit breaker



Product Features

- Field-Adjustable Settings: Allows for precise on-site customization of both overload (I_r) and short-circuit (I_m) protection settings for optimized coordination.
- Dual Protection Curves: Available with trip units optimized for either "Power Distribution" or "Motor Protection" applications.
- Proven Robustness: Designed for reliable operation across a wide temperature range (-35°C to +70°C) and at high altitudes up to 2000m.
- Accessory Compatibility: Supports a full range of accessories, including shunt releases and undervoltage trips, for extended control capabilities.

Compliance

- Meets international and regional standards including

IEC/EN 60947-1(General Rules)	GB/T 14048.1
IEC/EN 60947-2(Circuit-Breakers)	GB/T 14048.2
IEC/EN 60947-3(Switchgear)	GB/T 14048.3
IEC/EN 60947-4(Contactors & Motor-Starters)	GB/T 14048.4

Selection Guide

CQM6 RT - 160 H Z / 3 300 2 A Q1 D Q 2

Product code	Shell frame grade	Breaking capacity	Operating method				
CQM6	RT	160	C				
Molded case circuit breaker	RT stands for thermomagnetically adjustable T, A stands for single adjustable (i.e.,thermally adjustable/magnetically fixed).		C	S	M	H	
		160	160	25/18	35/25	50/35	/
		250	250	25/18	35/25	50/35	/
		630	630	/	35/25	50/35	75/75
		800	800	/	35/25	50/35	75/75

Operating method	The number of poles	Decoupler method and internal accessories	Rated current A	
P	4	300	125A	
P:Motorized operation Z:Turn the handle W:Direct operation DElectric operation DC1DC 2,DC3	2: 2-pole 3: 3-pole 4: 4-pole	The first digit indicates the type of detent 2:Instantaneous detent only 3:Duplicate detent Note:The last two digits are the accessory designator(see accessory table).	160	32,40,50,63,80,100,125,140,160
			250	100,125,140,160,180,200,225,250
			630	250,315,350,400,500,630
			800	500,630,700,800

Application	Optional code for Level 4 products
2	A
1:For power distribution	A:N-pole unprotected,not combinable A
2:For motor protection	B:N-pole unprotected,combinable

Accessory Voltage			Motorized operating voltage		Installation	Whether to install a terminal block
Q1			D1		Q	2
Undervoltage detent UVT	Shunt release Shunt	Auxiliary alarm Auxiliary	DC1	DC3 D5:AC230V	Q:Front of plate H:Rear of plate C:Inserted	1:No installation 2:Installation
Q1:AC220V	F1:AC220V	J1:AC125V	D1:AC220V	D6:AC110V		
Q2:AC240V	F2:AC380V	J2:AC250V	D2:AC230V	D7:DC220V		
Q3:AC380V	F3:DC110V	J3:DC125V	D3:AC380V	D8:DC110V		
			D4:AC400V	D9:AC110-240V		
				D10:DC100-220V		
Q4:AC415V	F4:DC24V	J4:DC24V				

Accessory List

Model number	CQM6T/A.RT-160	CQM6T/A.RT-250	CQM6T/A.RT-630	CQM6T/A.RT-800
Breaking capacity	C,S,M	C,S,M	S,M,H	S,M,H
Number of poles	3,4	3,4	3,4	3,4
Accessory code				
208、308	Alarm Switch			
210、310	Shunt Release			
220、320	Auxiliary Switch			
230、330	Undervoltage Release			
240、340	Shunt Release and Auxiliary Switch			
260、360	Two Auxiliary Switches			
270、370	Auxiliary Switch and Undervoltage Release			
218、318	Shunt Release and Alarm Switch			
228、328	Auxiliary Switch and Alarm Switch			
238、338	Undervoltage Release and Alarm Switch			
248、348	Shunt Release, Auxiliary Switch and Alarm Switch			
268、368	Two Auxiliary Switches and Alarm Switch			
278、378	Auxiliary Switch, Undervoltage Release and Alarm			
280、380	Two Auxiliary Switches and Shunt Release			

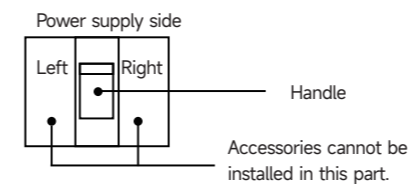

- Alarm switch
- Auxiliary switch
- Undervoltage release
- Shunt trip

1. MH can provide three new products right auxiliary switch, left shunt and left undervoltage for customers to choose.
2. In 220,320,240,340,270,370 specifications, the auxiliary switch can be used for Mopairs of switches, which should be specified when ordering.

Main Technical Parameters

Model number		CQM6T/A.RT-160			CQM6T/A.RT-250		
Rated current of frame level Inm(A)		160			250		
Number of poles		3, 4			3, 4		
Rated current In(A),at 40°C,50°C,55°C		63,80,100,125,160			125,140,160,180,200,225,250		
Rated operating voltage Ue(V),AC 50/60Hz		400/415			400/415		
Rated insulation voltage Ui (V)		800			800		
Rated impulse withstand voltage Uimp(KV)		8			8		
Breaking capacity designation		C	S	M	C	S	M
Short-circuit breaking capacity Icu/Ics(kA) AC400/415V		25/18	35/25	50/35	25/18	35/25	50/35
Selectivity category		A	A	A	A	A	A
Number of operating cycles (cycle)		ON 6000			OFF 10000		
Trip mechanisms and protection types	Magnetic trip	Power distribution protection	●	●	●	●	●
		Motor protection	●	●	●	●	●
	Thermal-magnetic trip	Power distribution protection	●	●	●	●	●
		Motor protection	●	●	●	●	●
Accessory		Auxiliary contacts	●	●	●	●	●
		Alarm contacts	●	●	●	●	●
		Shunt disconnect	●	●	●	●	●
		Undervoltage detent	●	●	●	●	●
		Manual operating mechanism	●	●	●	●	●
		Motorized operating mechanism	●	●	●	●	●
		Backplane wiring	●	●	●	●	●
		Inserted	●	●	●	●	●
		Coupling plate	●	●	●	●	●
		Partition between phases	●	●	●	●	●
Derivative products		Dedicated for prepayment electric meters	●	●	●	●	●
		Overload alarm without trip	●	●	●	●	●
Overall dimensions (mm) (a-b-c-ca)			3 P	90-155-70-94	90-155-84-109	105-165-70-96	105-165-93-120
			4 P	120-155-70-94	120-155-84-109	140-165-70-96	140-165-93-120

Note: ● for optional accessories; "-" for no optional accessories.

Main Technical Parameters

Model number		CQM6T/A.RT-630			CQM6T/A.RT-800		
Rated current of frame level Inm(A)		630			800		
Number of poles		3,4			3,4		
Rated current In(A),at 40°C,50°C,55°C		250,315,350,400,500,630			500,630,700,800		
Rated operating voltage Ue(V),AC 50/60Hz		400/415			400/415		
Rated insulation voltage Ui (V)		800			800		
Rated impulse withstand voltage Uimp(KV)		8			8		
Breaking capacity designation		S	M	H	S	M	H
Short-circuit breaking capacity Icu/Ics(kA) AC400/415V		35/25	50/35	75/75	35/25	50/35	75/75
Selectivity category		A	A	A	A	A	A
Number of operating cycles (cycle)		ON 3000			OFF 8000		
Trip mechanisms and protection types	Magnetic trip	Power distribution protection	●	●	●	●	●
		Motor protection	●	●	●	●	●
	Thermal-magnetic trip	Power distribution protection	●	●	●	●	●
		Motor protection	●	●	●	●	●
Accessory		Auxiliary contacts	●	●	●	●	●
		Alarm contacts	●	●	●	●	●
		Shunt disconnect	●	●	●	●	●
		Undervoltage detent	●	●	●	●	●
		Manual operating mechanism	●	●	●	●	●
		Motorized operating mechanism	●	●	●	●	●
		Backplane wiring	●	●	●	●	●
		Inserted	●	●	●	●	●
		Coupling plate	●	●	●	●	●
		Partition between phases	●	●	●	●	●
Derivative products		Dedicated for prepayment electric meters	●	●	●	●	●
		Overload alarm without trip	●	●	●	●	●
Overall dimensions (mm) (a-b-c-ca)			3 P	210-275-105-155			210-275-105-155
			4 P	280-275-105-155			280-275-105-155

Note: ● for optional accessories; "-" for no optional accessories.

Operating Characteristics

1. The inverse time operating characteristics of power distribution circuit breakers when all poles are energized simultaneously at an ambient air temperature of +40°C (with no humidity compensation) are shown in the following table:

Test current designation	Setting current multiple	Conventional time	Initial state
		$I_n \leq 63$ $I_n > 63$	
Conventional non-tripping current	1.05	$\geq 1h$ $\geq 2h$	Cool state
Conventional tripping current	1.30	$< 1h$ $< 2h$	Hot state

2. The inverse time action characteristics of circuit breakers for motor protection without humidity compensation when all poles are reenergized simultaneously at an ambient air temperature of +40°C are shown in the following table.

Test current designation	Setting current multiple	Conventional time	Initial state
		$I_n \leq 800$	
Conventional non-tripping current	1.0	$\geq 2h$	Cool state
Conventional tripping current	1.2	$< 2h$	Hot state

3. Action characteristics under short-circuit condition: The short-circuit current setting value of the instantaneous tripper of the circuit breaker for power distribution is $10I_n$.
The short-circuit current setting value of the instantaneous tripper of the circuit breaker for motor protection is $12I_n$.
The accuracy of the short-circuit current setting value of the instantaneous tripper is 20% of the short-circuit current setting value.

CQMGT/A.RT-160 Operating Characteristic Curve

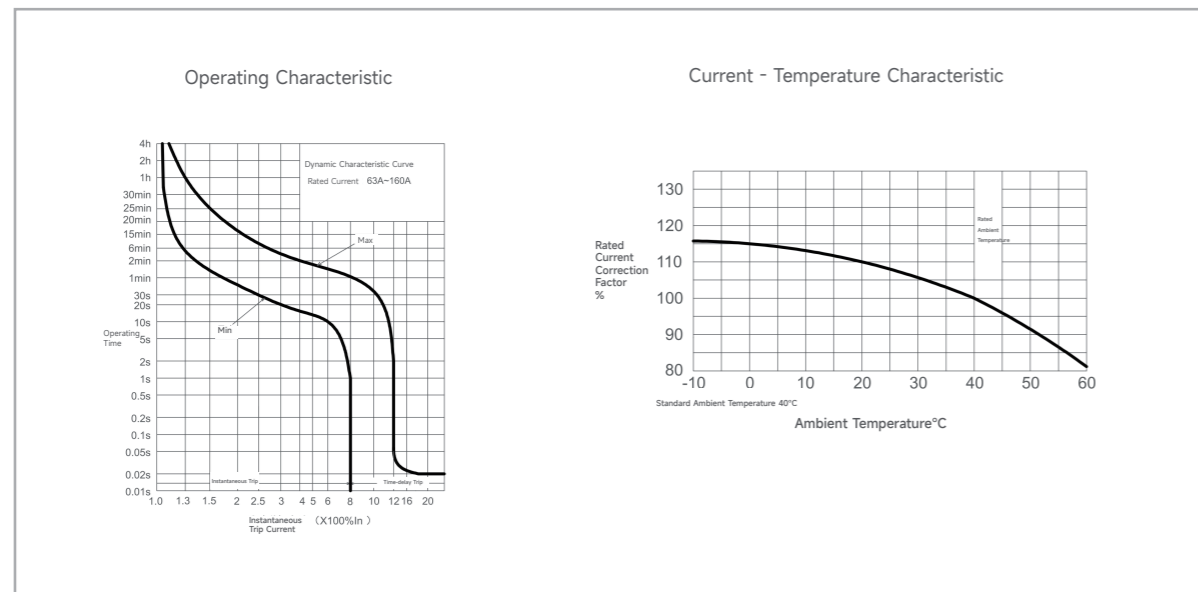

CQMGT/A.RT-250 Operating Characteristic Curve

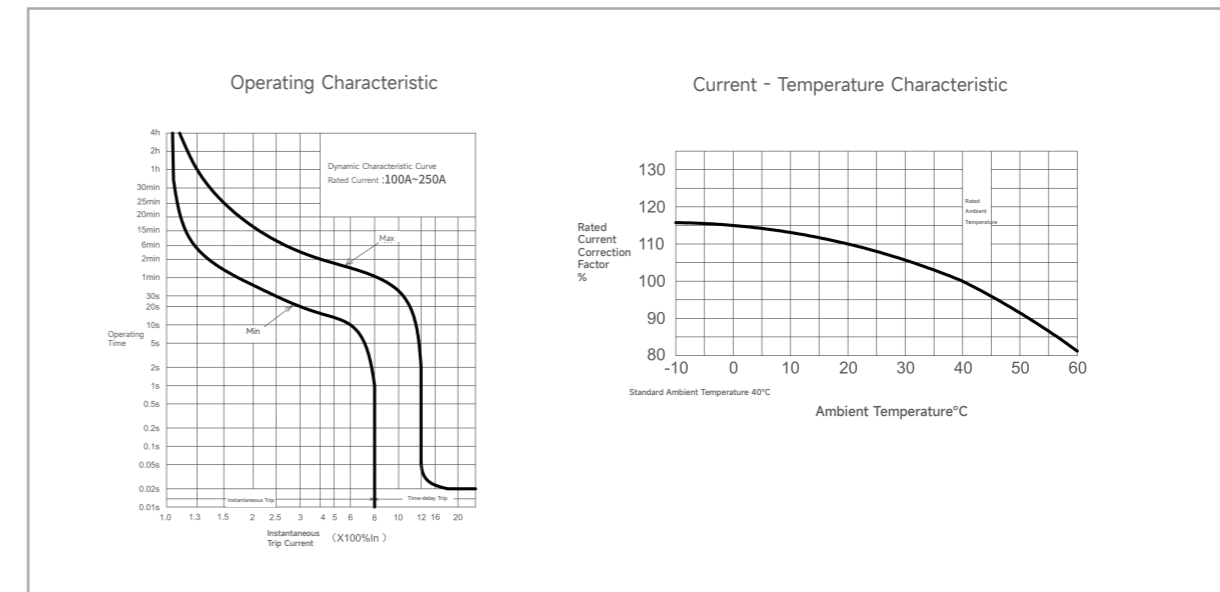

CQMGT/A.RT-630 Operating Characteristic Curve

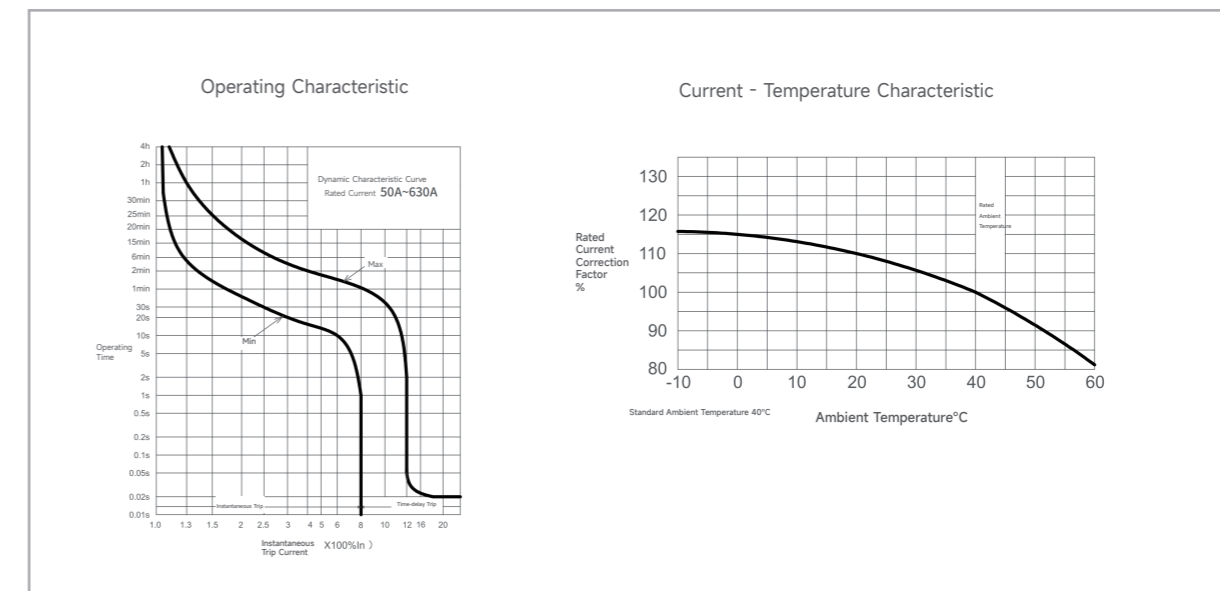

CQMGT/A.RT-800 Operating Characteristic Curve

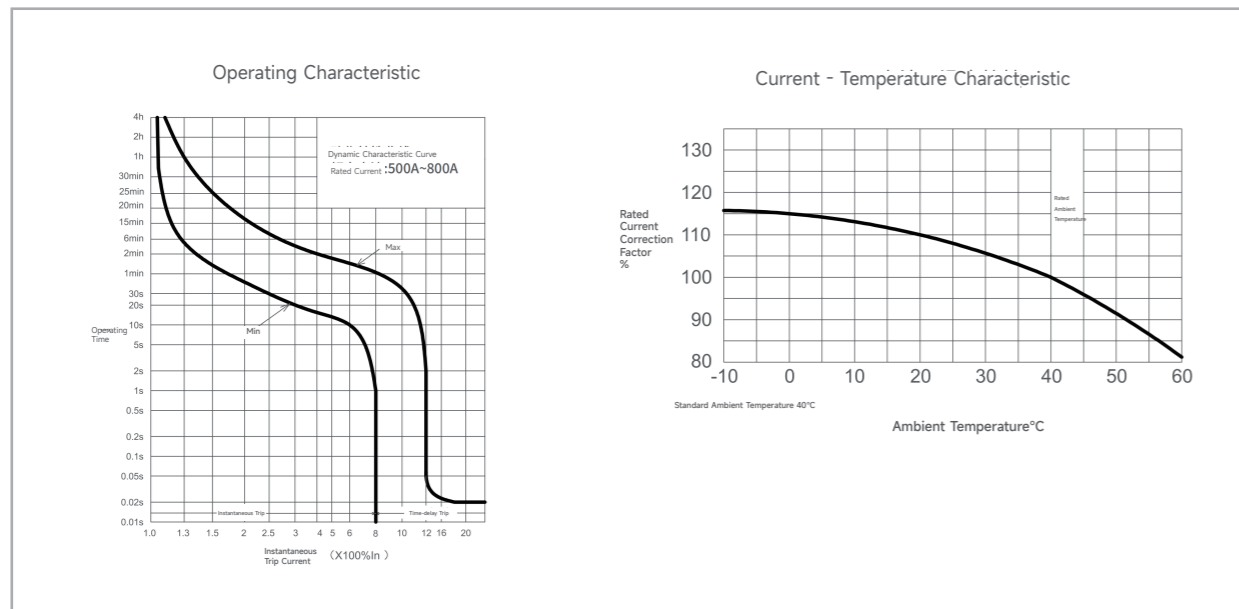

Outline and Installation Dimensions(mm)

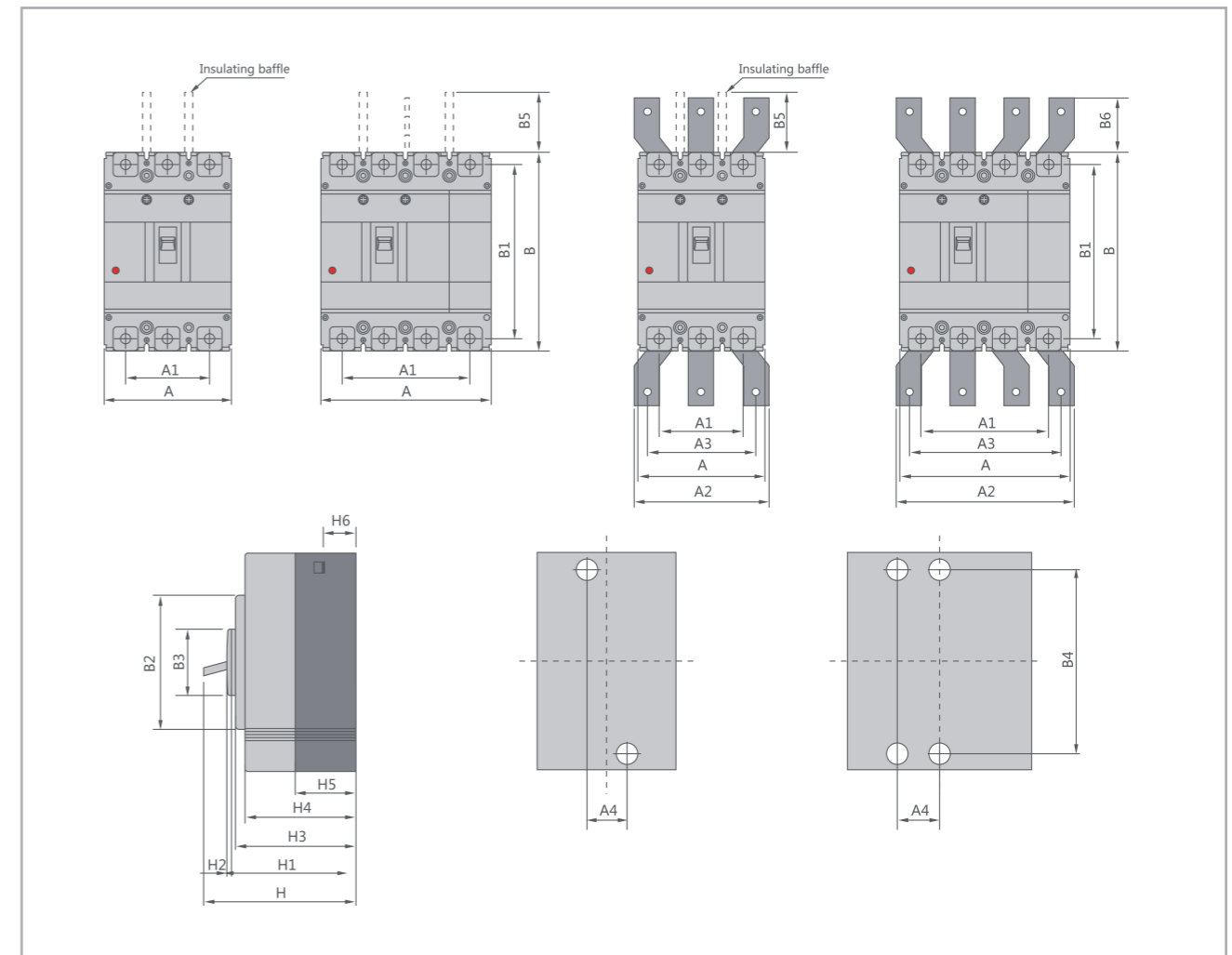

Molded case circuit breaker	Overall dimension																		Installation dimensions		Boit			
	A		A1		A2		A3		B	B1	B2	B3	B5	B6	H	H1	H2	H3	H4	H5		H6	A4	B4
	3P	4P	3P	4P	3P	4P	3P	4P																
CQM6T/A.RT-160CS	90	120	60	90	-	-	-	-	155	134	103	50	50	-	94	72	4	70	61	41	24	30	132	M8
CQM6T/A.RT-160M	90	120	60	90	-	-	-	-	155	134	103	50	50	-	109	83	4	83	76	24.5	24.5	30	132	M8
CQM6T/A.RT-250CS	105	140	70	105	-	-	-	-	165	144	103	50	100	-	96	72	4	70	61	46	24	35	126	M8
CQM6T/A.RT-250M	105	140	70	105	-	-	-	-	165	144	102	50	110	-	120	95	4	91	84	22.5	24	35	126	M8
CQM6T/A.RT-630SMH	140	185	88	132	140	196	112	168	257	230	179	90	110	42	155	107	5	105	97	64	35	44	194	M10
CQM6T/A.RT-800SMH	210	280	140	210	180	250	140	210	275	243	192	90	110	87	155	107	5	104	97	65	24	70	242.5	M12

CQM6E series

Electronic molded case circuit breaker



Product Features

- **Precise Electronic Trip:** Features an adjustable electronic release for highly accurate Long-Time, Short-Time, and Instantaneous (L-S-I) protection.
- **Advanced Ground Fault Protection:** Includes a dedicated ground fault (G) protection setting for enhanced system safety.
- **Visual Status Indication:** Equipped with an intuitive control panel featuring a current light bar and clear indicators for overload and pre-alarm status.
- **Communication Ready:** Provides the foundation for smart functionality, supporting integration with motorized operators for remote control.

Compliance

- Meets international and regional standards including

IEC/EN 60947-1(General Rules)	GB/T 14048.1
IEC/EN 60947-2(Circuit-Breakers)	GB/T 14048.2
IEC/EN 60947-3(Switchgear)	GB/T 14048.3
IEC/EN 60947-4(Contactors & Motor-Starters)	GB/T 14048.4

Selection Guide

CQM6 **E** - **160** **P/3** **400** **160A** **2** **A**

Product code	Shell frame grade	Shell frame rating current optional designator	Breaking capacity			
CQM6	E	160		S	M	H
Molded case circuit breaker	E Electronically Adjustable	160	160	/	50/35	50/50
		250	250	/	50/35	50/50
		630	630	35/25	50/35	75/75
		800	800	35/25	50/35	75/75
		1250	1250	35/25	50/35	75/75

Operating method	Number of poles	Decoupler method and internal accessories
P:Motorized operation Z:Turn the handle W:Direct operation	4 3-pole 4-pole	300 2: Intelligent disconnectors Note: The last two digits are the accessory code (see attachment)

Function	Four-pole products can be selected code
2	A

1: For power distribution
2: For motor protection



A: N-pole without protection, can not be combined
B: N-pole without protection, can be combined
C: N-pole with protection, can be combined
D: N-pole with protection, can not be combined
Note: If the customer does not have a clear request, four-pole products will be defaulted to the B category

Accessory List

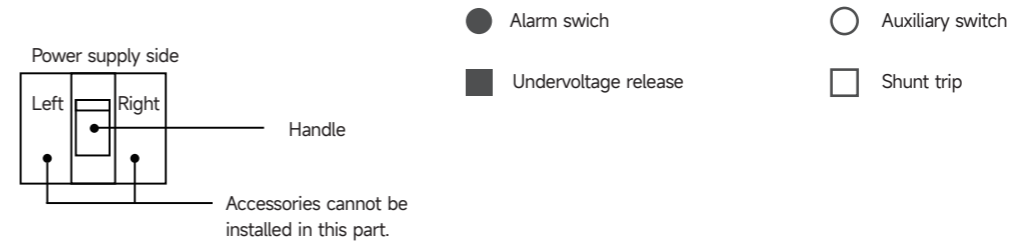
Model number	CQM6E-160	CQM6E-250	CQM6E-630	CQM6E-800	CQM6E-1250
Breaking capacity	M,H	M,H	S,M,H	S,M,H	S,M,H
Number of poles	3,4	3,4	3,4	3,4	3,4
Accessory code					
308	Alarm Switch				
310	Shunt Release				
320	Auxiliary Switch				
330	Undervoltage Release				
340	Shunt Release and Auxiliary Switch				
360	Two Auxiliary Switches				
370	Auxiliary Switch and Undervoltage Release				
318	Shunt Release and Alarm Switch				
328	Auxiliary Switch and Alarm Switch				
338	Undervoltage Release and Alarm Switch				
348	Shunt Release, Auxiliary Switch and Alarm Switch				
368	Two Auxiliary Switches and Alarm Switch				
378	Auxiliary Switch, Undervoltage Release and Alarm Switch				
380	Two Auxiliary Switches and Shunt Release				



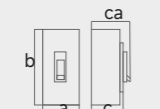

Main Technical Parameters

Model number		CQM6E-160		CQM6E-250	
Rated current of frame level Inm(A)		160		250	
Number of poles		3,4		3,4	
Rated current In(A),at 40°C,50°C,55°C		32, 63, 125, 160		160,250	
Rated operating voltage Ue(V),AC 50/60Hz		400/415		400/415	
Rated insulation voltage Ui (V)		800		800	
Rated impulse withstand voltage Uimp(KV)		8		8	
Breaking capacity designation		M	H	M	H
Short-circuit breaking capacity Icu/Ics(kA)		AC400/415V 50/35 50/50		50/35 50/50	
Rated short-time withstand current Icw(kA),1s		AC400/415V 2 2		5 5	
Selectivity category		B	B	B	B
Number of operating cycles (cycle)	ON	6000		6000	
	OFF	10000		10000	
Electronic decouping (adjustable)	Power distribution protection	●	●	●	●
	Motor protection	●	●	●	●
Accessory	Auxiliary contacts	●	●	●	●
	Alarm contacts	●	●	●	●
	Shunt disconnect	●	●	●	●
	Undervoltage detent	●	●	●	●
	Manual operating mechanism	●	●	●	●
	Motorized operating mechanism	●	●	●	●
	Backplane wiring	●	●	●	●
	Inserted	●	●	●	●
	Coupling plate	●	●	●	●
Partition between phases	●	●	●	●	
Overall dimensions (mm) (a-b-c-ca)	 3 P	90-155-84-109		105-165-93-120	
	 4 P	120-155-84-109		140-165-93-120	

Note: ● for optional accessories; “-” for no optional accessories.

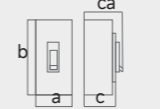
Main Technical Parameters

Model number		CQM6E-630			CQM6E-800			CQM6E-1250		
Rated current of frame level Inm(A)		630			800			1250		
Number of poles		3,4			3,4			3,4		
Rated current In(A),at 40°C,50°C,55°C		400, 630			630, 800			1000, 1250		
Rated operating voltage Ue(V),AC 50/60Hz		400/415			400/415			400/415		
Rated insulation voltage Ui (V)		800			800			800		
Rated impulse withstand voltage Uimp(KV)		8			8			8		
Breaking capacity designation		S	M	H	S	M	H	S	M	H
Short-circuit breaking capacity Icu/Ics(kA)		AC400/415V 35/25 50/35 75/75			35/25 50/35 75/75			35/25 50/35 75/75		
Rated short-time withstand current Icw(kA),1s		AC400/415V 8 8 8			10 10 10			19.2 19.2 19.2		
Selectivity category		B	B	B	B	B	B	B	B	B
Number of operating cycles (cycle)	ON	3000			3000			1000		
	OFF	8000			8000			3000		
Electronic decouping (adjustable)	Power distribution protection	●	●	●	●	●	●	●	●	●
	Motor protection	●	●	●	●	●	●	●	●	●
Accessory	Auxiliary contacts	●	●	●	●	●	●	●	●	●
	Alarm contacts	●	●	●	●	●	●	●	●	●
	Shunt disconnect	●	●	●	●	●	●	●	●	●
	Undervoltage detent	●	●	●	●	●	●	●	●	●
	Manual operating mechanism	●	●	●	●	●	●	●	●	●
	Motorized operating mechanism	●	●	●	●	●	●	●	●	●
	Backplane wiring	●	●	●	●	●	●	●	●	●
	Inserted	●	●	●	●	●	●	●	●	●
	Coupling plate	●	●	●	●	●	●	●	●	●
Partition between phases	●	●	●	●	●	●	●	●	●	
Overall dimensions (mm) (a-b-c-ca)	 3 P	140-257-105-155			210-275-105-155			210-275-105-155		
	 4 P	185-257-105-155			280-275-105-155			280-275-105-155		

Note: ● for optional accessories; “-” for no optional accessories.

Characteristic curve

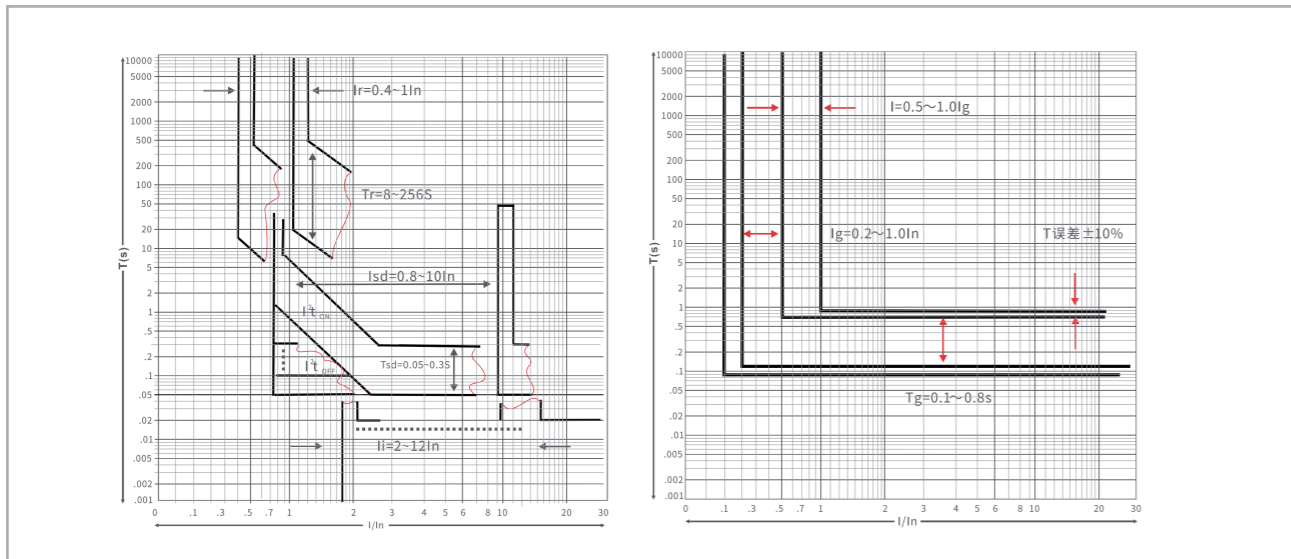

Intelligent Release Adjustment Panel

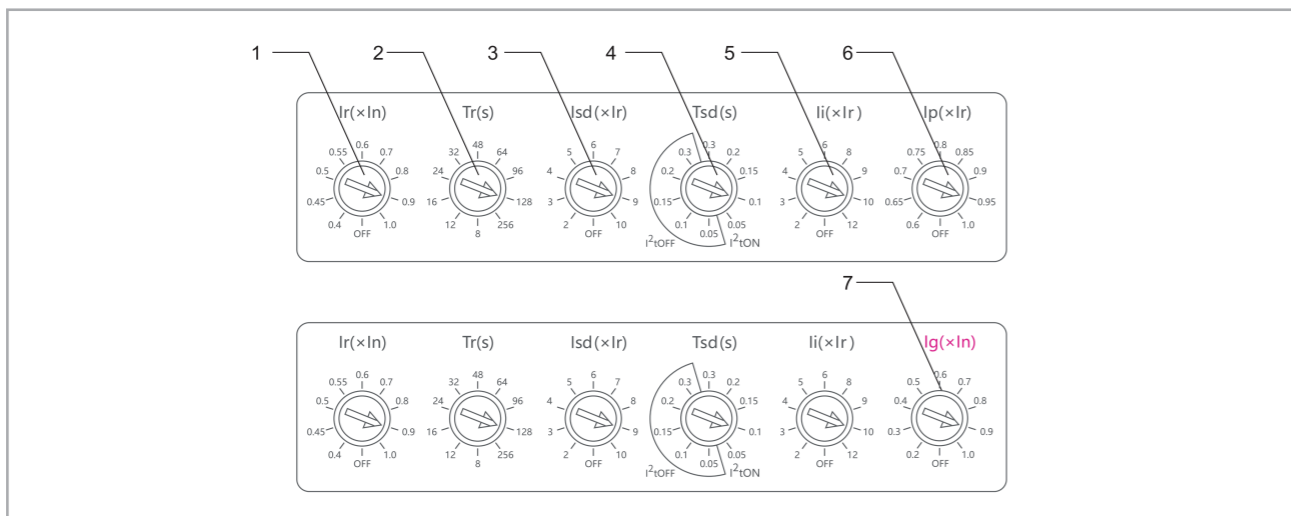

1. Ir: Rated Current (Ir) Setting Dial
The setting dial for the rated current, applicable to 160-1250 frame sizes. The selectable settings on the front panel are: 0.4, 0.45, 0.5, 0.55, 0.6, 0.7, 0.8, 0.9, 1.0, OFF.
2. Tr: Long-Time Delay (Tr) Setting Dial
The setting dial for the overload long-time delay. When the current passing through the circuit breaker reaches 1.5 times Ir (×Ir), the breaker trips within the set time. The selectable settings are: 8s, 12s, 16s, 24s, 32s, 48s, 64s, 96s, 128s, 256s.
3. Isd: Short-Time Delay Current (Isd) Setting Dial
The setting dial for the short-time delay current multiplier. Selectable settings are: 2, 3, 4, 5, 6, 7, 8, 9, 10, OFF. When a short-circuit current equal to the set value (×Ir, ×In) passes through the breaker, it will trip after a time delay.
4. Tsd: Short-Time Delay Operating Time (Tsd) Setting Dial
The setting dial for the short-time delay operating time. It is divided into inverse-time protection (I²t ON) and definite-time protection (I²t OFF). Selectable settings are: 0.05s, 0.1s, 0.15s, 0.2s, 0.3s. When a short-circuit current equal to Isd passes through the breaker, it will trip within the set time.
5. Ii: Instantaneous Current (Ii) Setting Dial
The setting dial for the instantaneous current multiplier. Selectable settings are: 2, 3, 4, 5, 6, 8, 9, 10, 12. When a short-circuit current equal to the set value (×In) passes through the breaker, it will trip instantaneously.
6. Ip: Pre-alarm Current (Ip) Setting Dial
The setting dial for the pre-alarm current multiplier. Selectable settings are: 60%, 65%, 70%, 75%, 80%, 85%, 90%, 95%, 100%, OFF. When the current passing through the breaker reaches the set value (×Ir, ×In), the pre-alarm indicator light will illuminate.
7. Ig: Ground Fault Current (Ig) Setting Dial
The setting dial for the ground fault current multiplier. Selectable settings are: 0.2, 0.3, 0.4, 0.5, 0.6, 0.7, 0.8, 0.9, 1.0, OFF. When the ground fault current passing through the breaker reaches the set value (×In), the breaker will trip due to the ground fault.

Characteristics of Intelligent Release: It has protection functions such as overload long-delay inverse time, short-circuit short-delay inverse time, short-circuit short-delay fixed time, and short-circuit instantaneous action. These functions can be set by the user to form the required protection characteristics. The inverse time action characteristics of long-delay overcurrent protection are shown in the table:

Current	time of action
1.05Ir	>2h inoperative(In>63A), 1h inoperative (In≤63A)
1.3r	<1h action
1.51r	Setting time tr(s) Inm-125A、250A、400A、630A、800A、1250A 8、12、16、24、32、48、64、96、128、256

Remarks: Tolerance of operation value is ±10%, tolerance of operation time is ±15%.
Short delay overcurrent protection action characteristics

When Tsd is within the I²tON stall range, it is a fixed time limit:

Current	time of action
I≤Isd≤6Ir counter-time limit	I² T2=(6XIr)² Tsd
I>Isd and I≥6Ir	Consolidation time
Inverse time limit to fixed time limit	Inaccuracies
Returnable time	Returnable time

Remarks: I is the actual passing current, T2 is the actual action time, Isd is the set short delay current, Tsd is the set short delay action time

When Tsd is in the range of I²tOFF gear, it is fixed time limit:

Current	time of action
I≤Isd	Consolidation time
I>Isd Current Error±10%	Inaccuracies
Returnable time	Returnable time

Remarks: I is the actual passing current, T2 is the actual action time; Isd is the short delay current, Tsd is the short delay action time.

Short-circuit transient protection action characteristics

Current	time of action
Ii=(2,3,4,5,6,8,9,10,12)×In	Operating current
Motion Characteristics	Minimum operating current 0.9Ii Maximum inoperative current 1.1Ii
time of action	<0.1s

Grounding protection operating characteristics

Current	time of action
Ig=(0.2,0.3,0.4,0.5,0.6,0.7,0.8,0.9,1.0)×In	Ig≤0.9Ig Circuit breaker inoperative
Motion Characteristics	Ig>1.1Ig
time of action	Tg=0.4(fixed time limit)

The electronic striker panel indicators are set as follows



Overload pre-warning characteristics:

Load Current	$I < 1I_p$	$I \geq 1I_p$
Indicator status	Indicator light is not flashing, does not light up	Indicator light constant
Load Current	$I < 1.15I_p$	$I \geq 1.15I_p$
Indicator status	Indicator light is not on	Indicator light is on
Load Current	$\geq 0.4I_n$ (Single phase)	$1 \geq 0.2I_n$ (Tri-phase)
Indicator status	Indicator light is on	Indicator light is on

Note: 1. The above current error $\pm 10\%$.
2. The pre-alarm current needs to satisfy the startup current constraint, i.e., the current cannot be lower than the operating condition.

Outline and Installation Dimensions(mm)

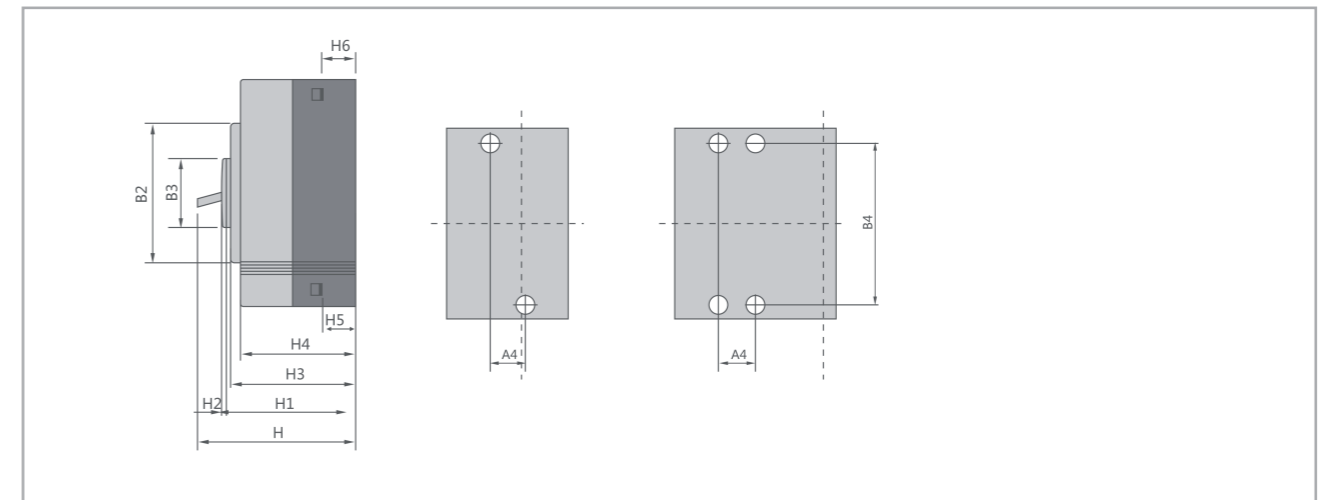
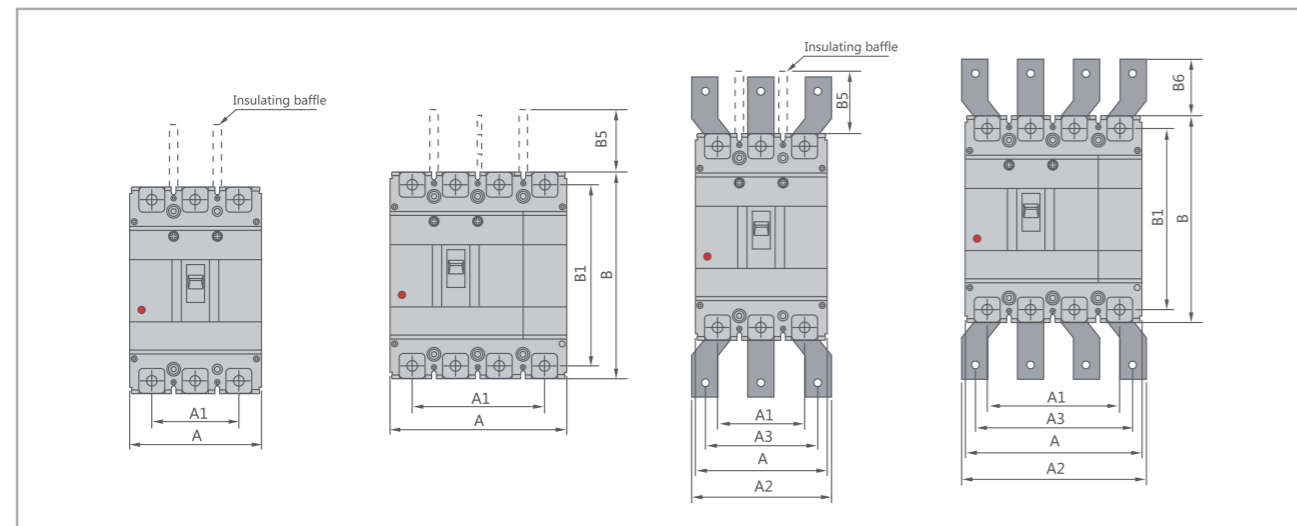

Molded case circuit breaker	Overall dimension																		Installation dimensions		Boit			
	A		A1		A2		A3		B	B1	B2	B3	B5	B6	H	H1	H2	H3	H4	H5		H6	A4	B4
	3P	4P	3P	4P	3P	4P	3P	4P																
CQM6E-160	90	120	60	90	-	-	-	-	155	134	102	50	50	-	109	83	4	83	76	24.5	24.5	30	132	M8
CQM6E-250	105	140	70	105	-	-	-	-	165	144	102	50	110	-	120	95	4	91	84	22.5	24	35	126	M8
CQM6E-630	140	185	88	132	140	196	112	196	257	230	179	90	110	42	155	107	5	105	97	30	32	44	194	M10
CQM6E-800	210	280	140	210	180	250	140	250	275	243	192	90	110	87	155	107	5	104	97	25	25	70	242.5	M12
CQM6E-1250	210	280	140	210	180	250	140	250	275	243	192	90	110	87	155	107	5	104	97	25	25	70	242.5	M10*2

Appearance and installation dimensions at the rear of the panel

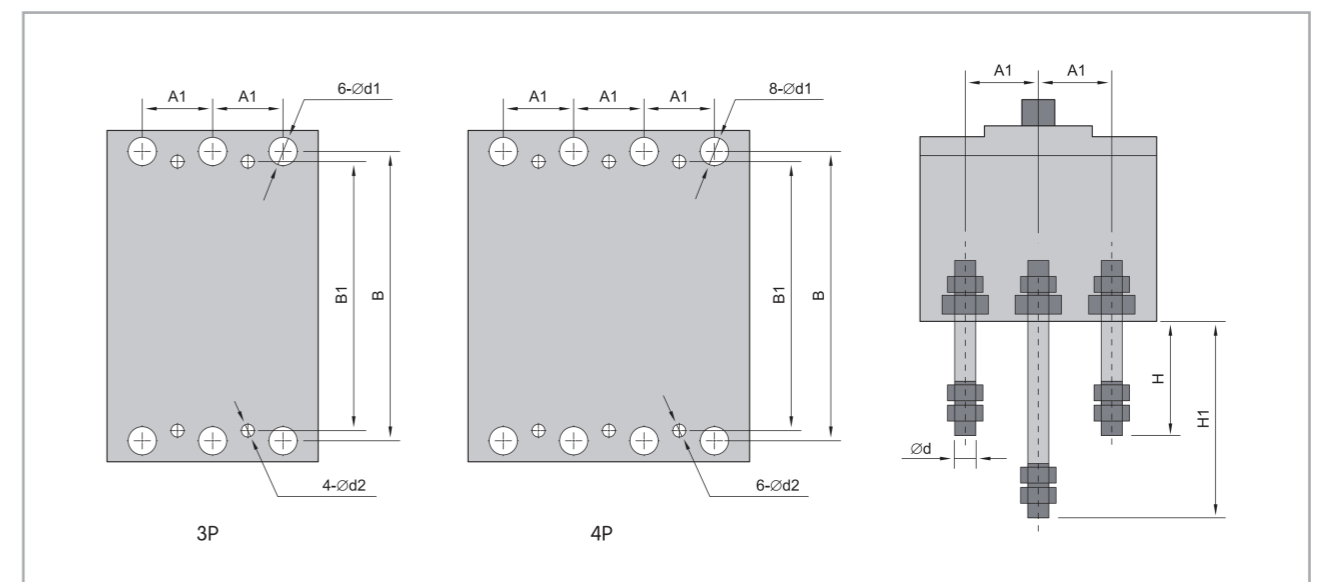

Appearance and installation dimensions of the rear part for the plug-in type(on the panel)

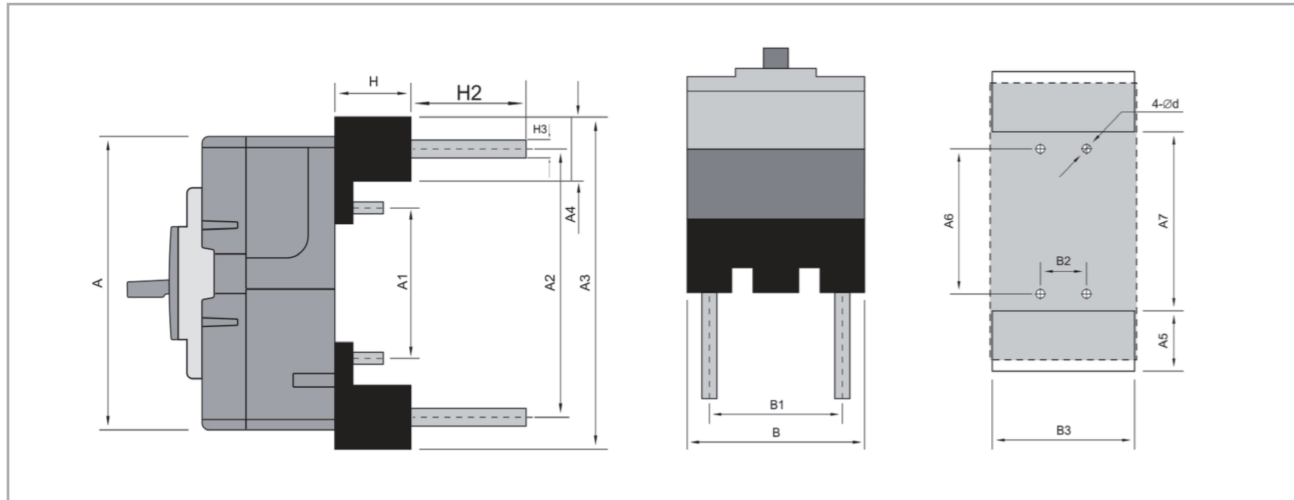

Molded case circuit breaker	B-board rear wiring dimensions										C Front-of-Board Wiring Dimensions				C Plug-in wiring size												
	A1	B	B1	H	H1	φd	φd1	φd2	φd3	A4	B4	A	A1	A2	A3	A4	A5	A6	A7	H	B	B1	B2	B3	φd	H2	H3
125	25	114	111	62	87	6	14	5	5	25	111	130	58	115	132	17.5	20	58	97	28	75	50	50	77	5.5	15	10.5
160	30	134	132	72	112	8	18	5	5	30	132	155	60	134	173	38	40	60	98	50	92	60	60	94	6.5	31	19.5
250	35	144	126	87	126	12	24	5	5	35	126	165	54	144	184	45	47	54	95	50	107	70	70	109	6.5	35	21.5
630	44	230	194	83	136	18	35	7	7	44	194	257	125	225	280	55	57	125	169	60	140	87	60	142	9	32	φ23
800	70	243	243	174	243	26	48	7	7	70	243	275	147	242	42	55	58	147	190	91	218	140	107	222	10.5	31	φ27

Appearance and installation dimensions of the rear part for the plug-in type(on the panel)

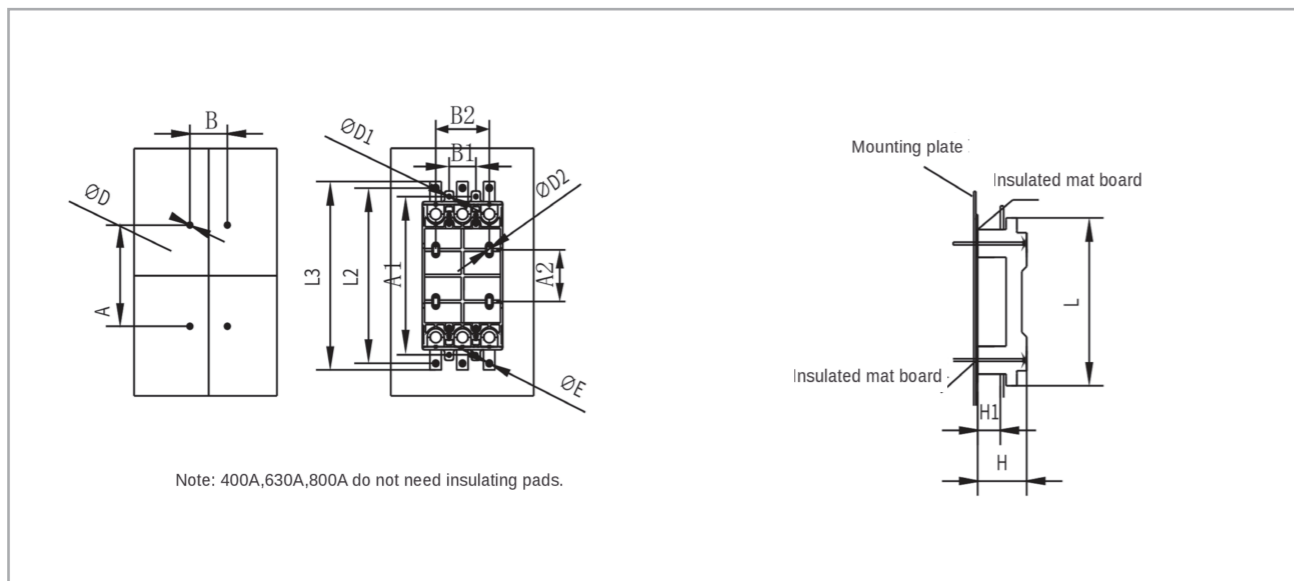

Model Number	A	E	L2	L3	D	E	H	H1	L	A1	B1	D1	A2	B2	D2
160	112	30	200	216	4.5	6.5	56	28	182	172	30	5.5	67	60	6.5
250	150	35	233	245	4.5	8.5	74	33	202	191	35	5.5	74	70	6.5
630	283	70	363	405	6.5	12.5	125	67	341	327	70	6.5	143	140	7
800	283	70	363	405	6.5	12.5	125	67	341	327	70	6.5	143	140	7

The internal accessories of CQM6E series include under-voltage detent,shunt detent,auxiliary alarm detent,its main technical parameters and wiring diagrams are as follows.

Under-voltage release device

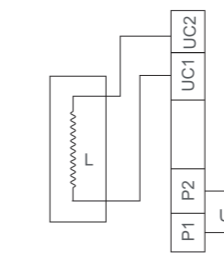

Internal accessories	Main Performance
Rated voltage of the power supply	Main Performance
AC220,AC240 AC380,AC415	A. When the supply voltage drops to 70%and 35%of the rated voltage, the undervoltage detector shall operate. B. When the electro-hydraulic voltage is lower than 35%of the rated voltage,the undervoltage detractor should not be able to absorb,in order to prevent the circuit breaker from closing. C.When the power supply voltage is equal to or greater than 85%of the rated voltage,the undervoltage detractor will ensure the absorption, and ensure the reliable closing of the circuit breaker.

Shunt release device

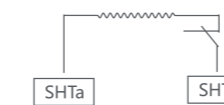

Rated supply voltage	Main Performance
DC24,DC110 AC220,AC380	The shunt release can operate reliably between 70%and 110%of the rated voltage value.

Auxiliary alarm contact



Rated voltage of power supply	Main performance
Auxiliary switch AC 125V 5A,AC 250V 3A DC 125V 0.4A,DC 125V 0.2A	Provides differentiated signals for circuit breakers in the "closed" and "open"positions.



Alarm switch AC 125V 5A,AC 250V 3A DC 125V0.4A,DC 125V 0.2A	Provides signals to distinguish between "normal operation" and "fault free release" positions of circuit breakers.
---	--



Auxiliary alarm switch AC 125V 5A,AC 250V 3A DC 125V 0.4A,DC125V 0.2A	Provides signals to distinguish between "closed", "open" and "fault free release" positions of the circuit breaker.
---	---

Internal accessory

DC3 Electric Operation Mechanism
 DC3 series electric operation mechanism is adopted advanced switching power supply technology,utilizing smallpermanent contact motordrive,small working current,suitable for 63-800A plastic case circuit breakers.

Model Number	DC3-125	DC3-160	DC3-250	DC3-630	DC3-800	
Compatible Model	CQM6-125	CQM6-160 CQM6RT-160 CQM6RE-160	CQM6RE-250 CQM6-250 CQM6L-250 CQM6RT-250 CQM6Z-250	CQM6-630 CQM6L-630 CQM6RT-630 CQM6RE-630 CQM6Z-630	CQM6-800 CQM6L-800 CQM6RT-800 CQM6RE-800 CQM6L-1250 CQM6RE-1250	
Overall Dimensions	A	25	30	35	44	70
	B	117	132	126	194	243
	C	73	90	90	130	130
	H	98	98(89.5)	102(92)	152	153
Rated voltated V	AC-110-240, DC100-220,DC24				AC 230,DC 220 AC 100,DC 110	
Starting current A	≤0.5				≤2	
Mechanical life(times)	14000			10000	5000	
Power(W)	14				35	

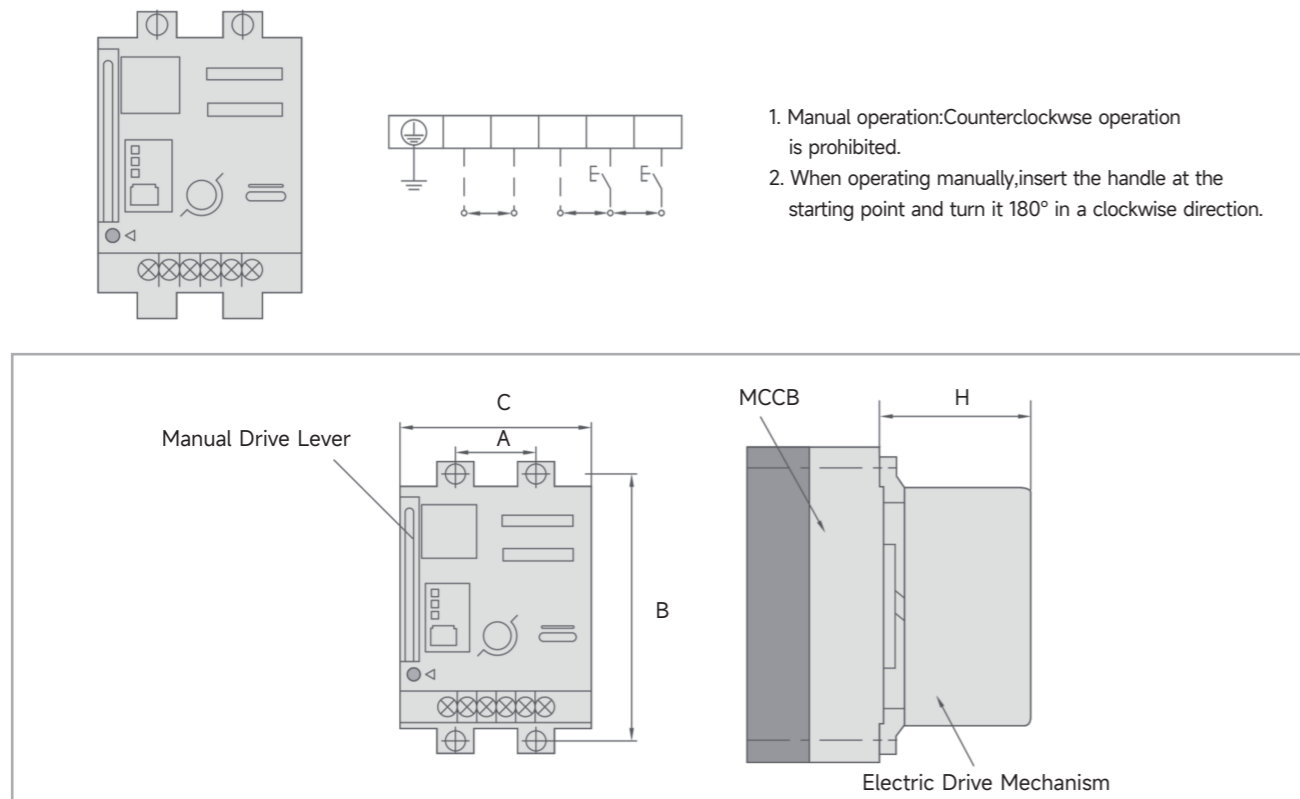

Manual operating mechanism

Shape of the circular handle and the door panel opening size (the distance from the center of the opening to the hinge should not be less than 200mm)

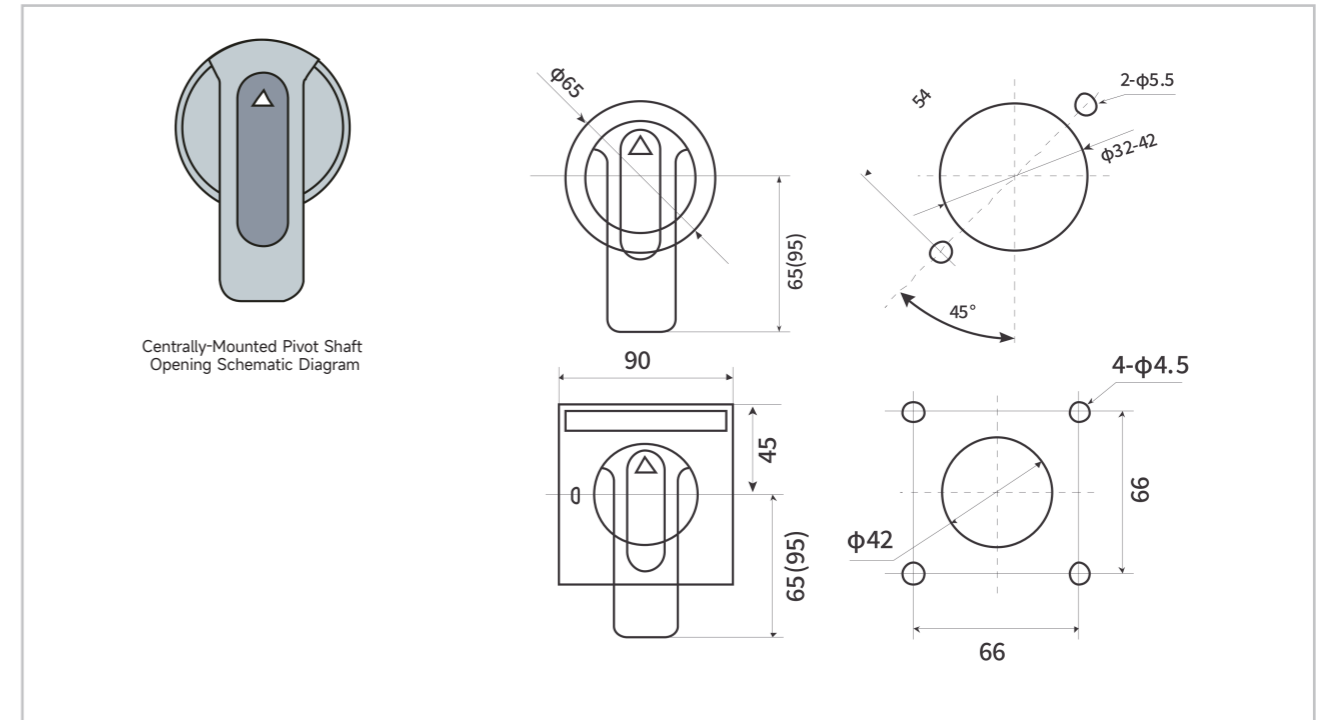

Outline and Installation Schematic Diagram of the Central Series Manual Operation Mechanism

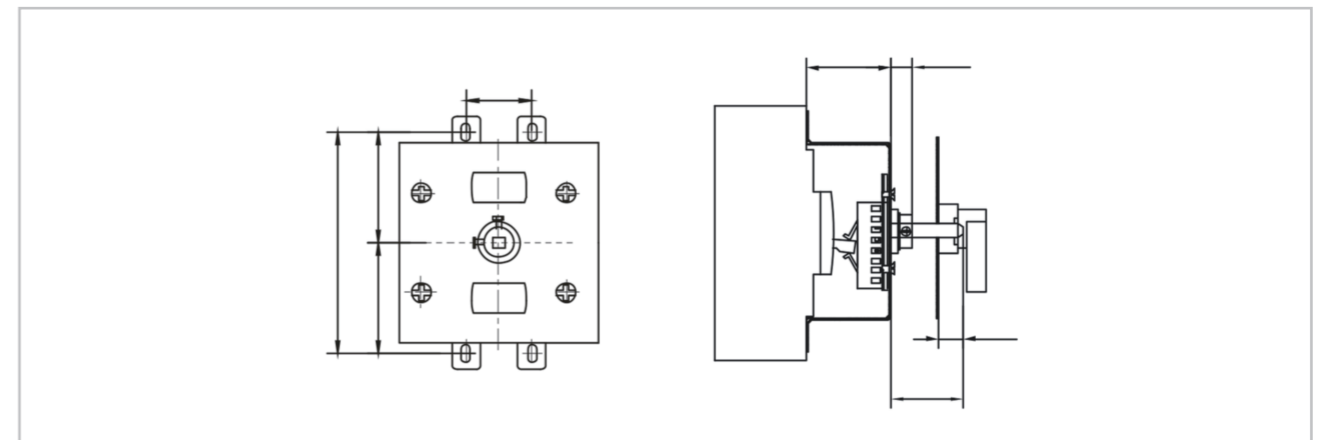

Hand-operated mechanism model	A	B	C	D	H
160	30	132	66	66	46
250	35	126	63	63	51
630	128	194	97	97	76
800	198	243	121.5	121.5	76
1250	198	243	121.5	121.5	76