

CHAC

CQR2 Series Thermal Overload Relay

PRODUCT CATALOG

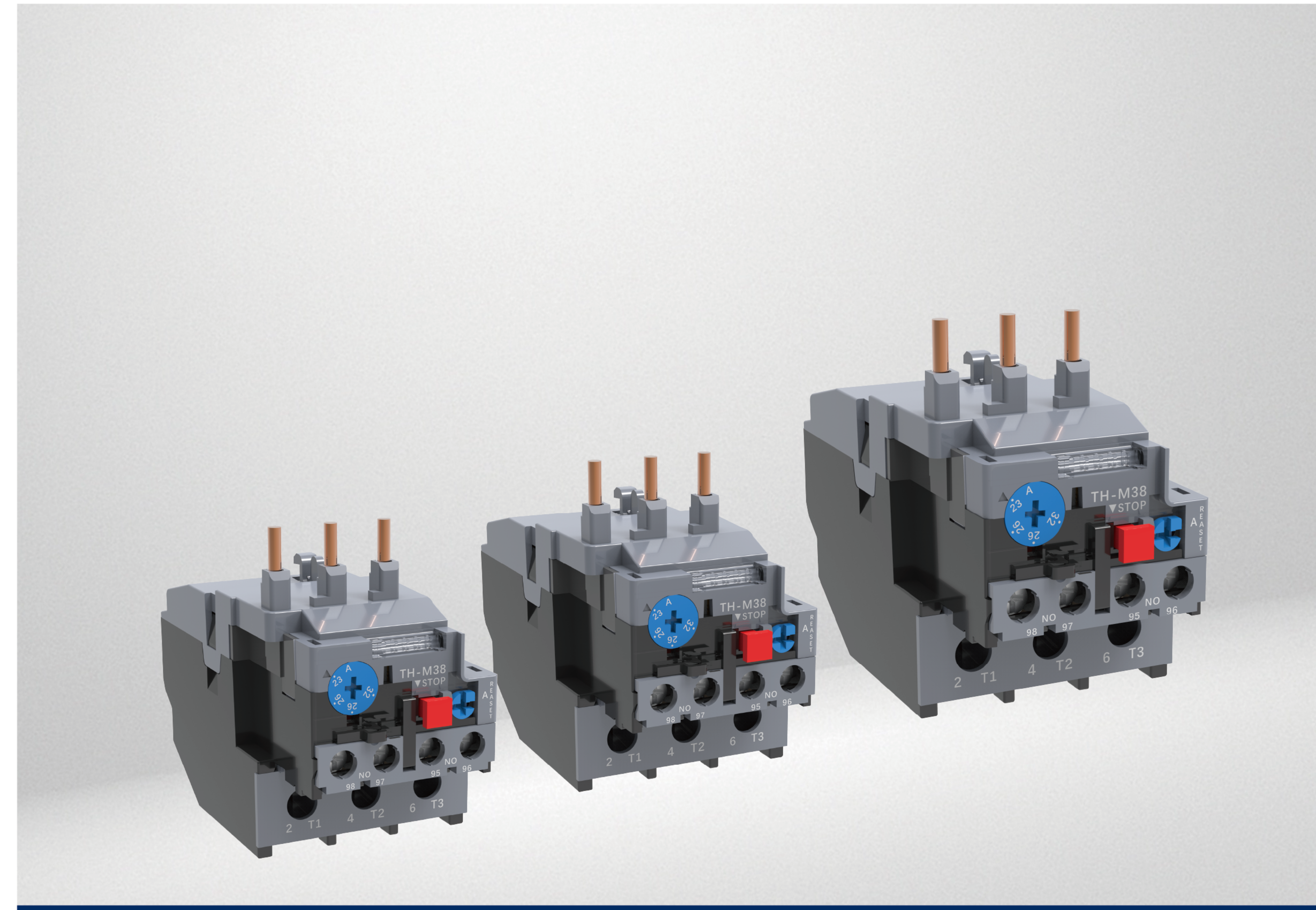

ZHEJIANG CHUANGQI ELECTRIC CO.,LTD.

- 🏠 Wenzhou Base
No. 18, Shahong Road, Beibaixiang Town, Yueqing City, Wenzhou, Zhejiang Province, China
- 🏠 Jiaxing Base
No. 61, Zhengyang West Road, Xiuzhou District, Jiaxing, Zhejiang Province, China
- ☎ 0577-27878806
- ✉ marketing@chac-en.com
- 🌐 www.chac-electric.com



LINKEDIN



WEBSITE

V2026.04-CHAC-MKT

CQR2 Series Thermal overload relay

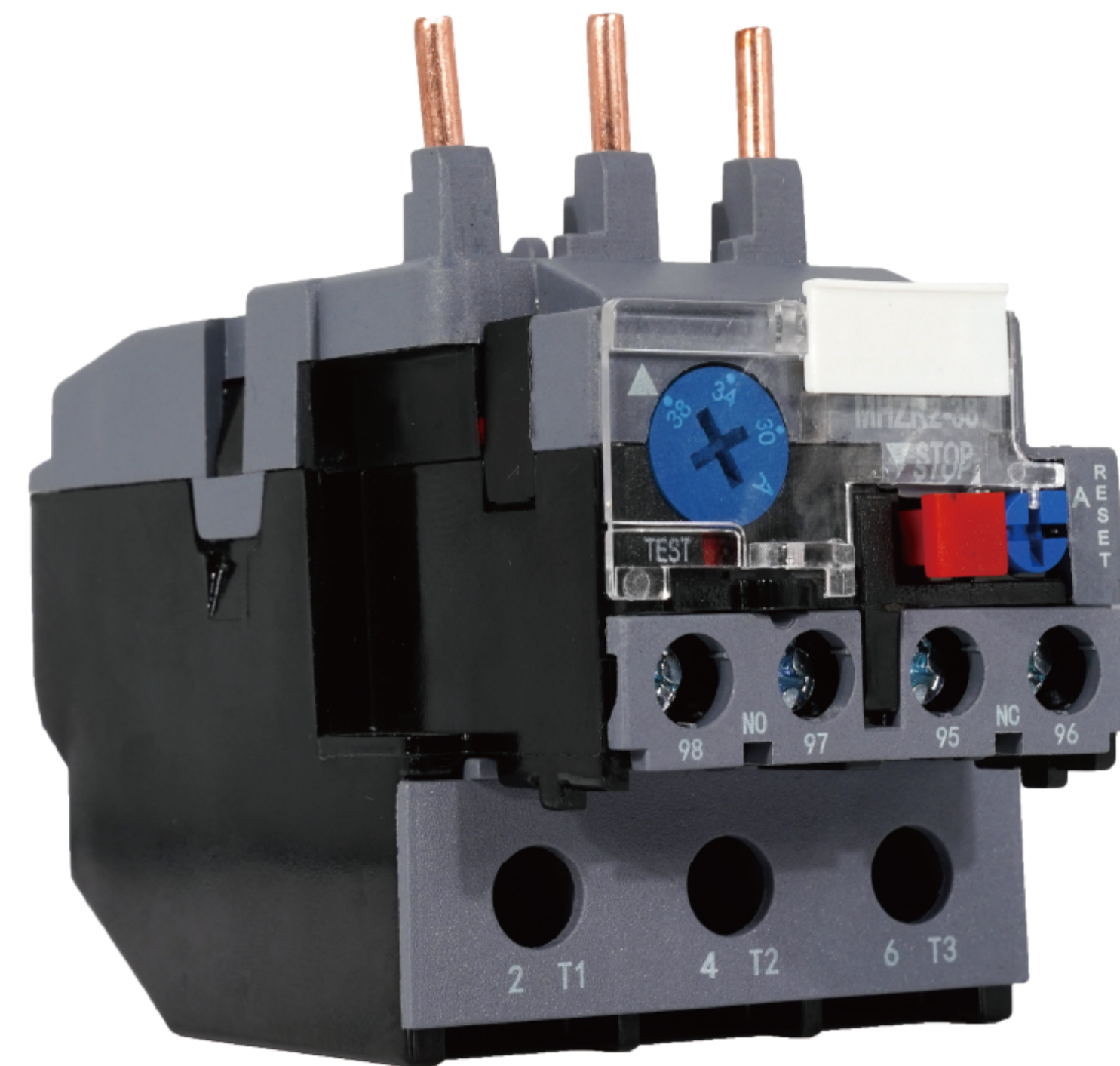

Type designation

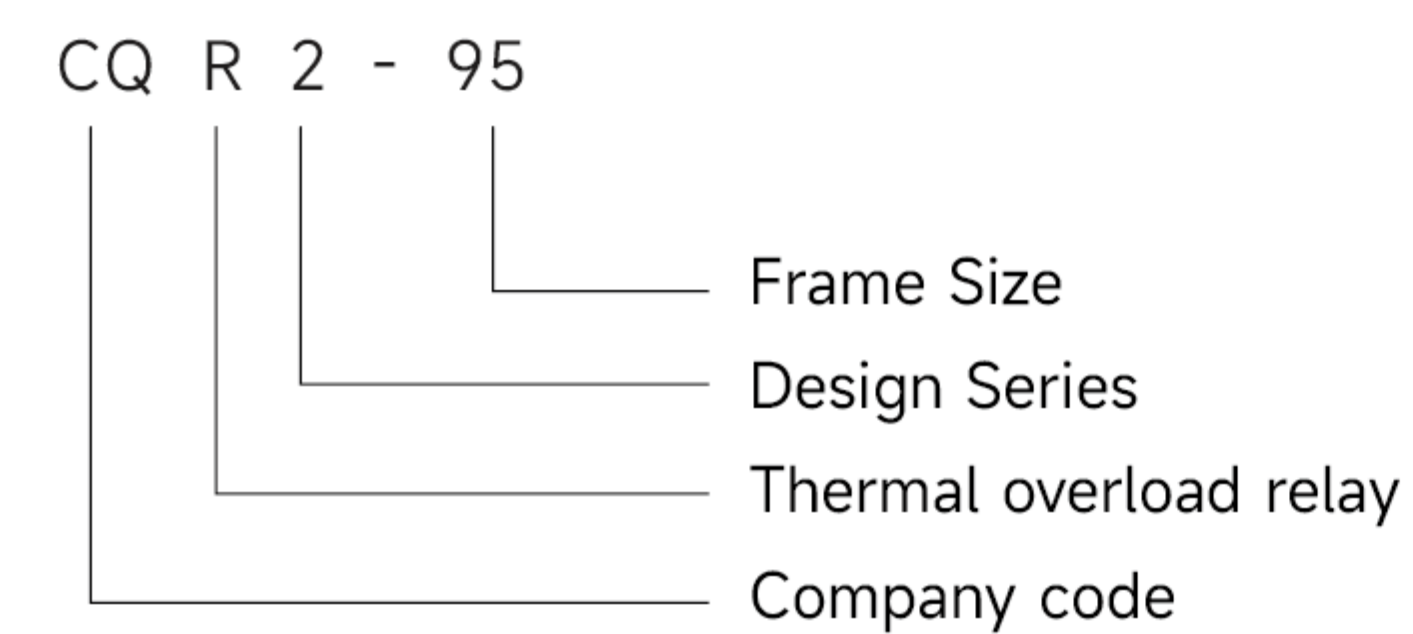

Technical Specifications

Product Model	CQR2-25	CQR2-38	CQR2-95		
Current rating	25	38	95		
Rated insulation voltage V	690	690	690		
Rated impulse withstand voltage V	6000	6000	6000		
Enclosure protection grade	IP20(Front side)	IP20(Front side)	IP20(Front side)		
Phase loss protection	●	●	●		
Manual and automatic reset	●	●	●		
Temperature compensation	●	●	●		
Tripping indication	●	●	●		
Test button	●	●	●		
Stop button	●	●	●		
Installation method	Insertable	Insertable	Insertable		
Auxiliary contact	1NO+1NC	1NO+1NC	1NO+1NC		
AC-15220V rated current A	2.73	2.73	2.73		
AC-15380V rated current A	1.58	1.58	1.58		
DC-13220V rated current A	0.2	0.2	0.2		
Cross-sectional area of conductor (mm ²)	Main circuit	Single-core or stranded wire	1 ~ 4	6-10	6-35
		Wire connection screw	M4	M4	M10
	Auxiliary circuit	Single-core or stranded wire	1 ~ 2.5	1-2.5	1-2.5
		Wire connection screw	M3.5	M3.5	M3.5

Product Features

- Comprehensive Motor Protection: Designed for three-phase squirrel-cage asynchronous motors, providing reliable overload and phase-failure protection.
- Wide Application Range: Suitable for AC systems up to 690V, with current ratings from 0.1A to 95A, supporting continuous or intermittent duty operations.
- Functional Versatility: Features temperature compensation, trip indication, automatic/manual reset, and a stop function for enhanced control and safety.
- Robust Design: Equipped with bimetallic strips (triple-phase), adjustable current settings, and auxiliary contacts (1NO + 1NC with electrical isolation).
- Easy Integration: Plug-in installation compatible with CQC6 series contactors for streamlined assembly.

Operating & Environmental Conditions

- Ambient Temperature: -5°C to +40°C (average temperature ≤ +35°C over 24h).
- Humidity: ≤50% at +40°C; ≤90% at lower temperatures (with condensation prevention).
- Altitude: Up to 2000m.
- Pollution Degree: Level 3.
- Method: Plug-in installation combined with MHZC5 series contactors.
- Enclosure Protection: IP20 (front-side).

Tripping Characteristics

Item	No.	Setting Current Multiple	Operating Time	Purpose / Test Condition
Overload Protection	1	1.05	No operation within 2 hours	Starting from Cold State
	2	1.2	Operation within 2 hours	Starting from Hot State (after Item 1)
	3	1.5	Operation within 2 minutes	Starting after reaching thermal equilibrium at setting current
	4	7.2	2S<TP≤10S	Starting from Cold State
Phase Failure Protection	5	Any Two Phases	No operation within 2 hours	Starting from Cold State
		One Phase		
	6	1.15	0	Operation within 2 hours

Adjustable Trip Setting Range

Product Model	Current adjustment range RC(A)	Plug-in contactors	Short-circuit protection fuse (A)	
			aM	gG
CQR2-25	0.1-0.16	CQC6(SM/KMNC1)-09 CQC6(SM/KMNC1)-12 CQC6(SM/KMNC1)-18 CQC6(SM/KMNC1)-25	0.25	2
	0.16-0.25		0.5	2
	0.25-0.40		1	2
	0.40-0.63		1	2
	0.63-1		2	4
	1-1.6		2	4
	1.6-2.5		4	6
	2.5-4		6	10
	4-6		8	16
	5.5-8		12	20
	7-10		12	20
	9-13		16	25
CQR2-38	12-18	CQC6(SM/KMNC1)-32	20	35
	17-25		25	50
CQR2-95	23-32	CQC6(SM/KMNC1)-40 CQC6(SM/KMNC1)-50 CQC6(SM/KMNC1)-65 CQC6(SM/KMNC1)-80 CQC6(SM/KMNC1)-95	40	63
	30-38		40	80
	17-25		25	50
	23-32		40	63
	30-40		40	100
	37-50		63	100
	48-65		63	100
	55-70		80	125
63-85	80	125		
80-95	100	160		

Selection Guide

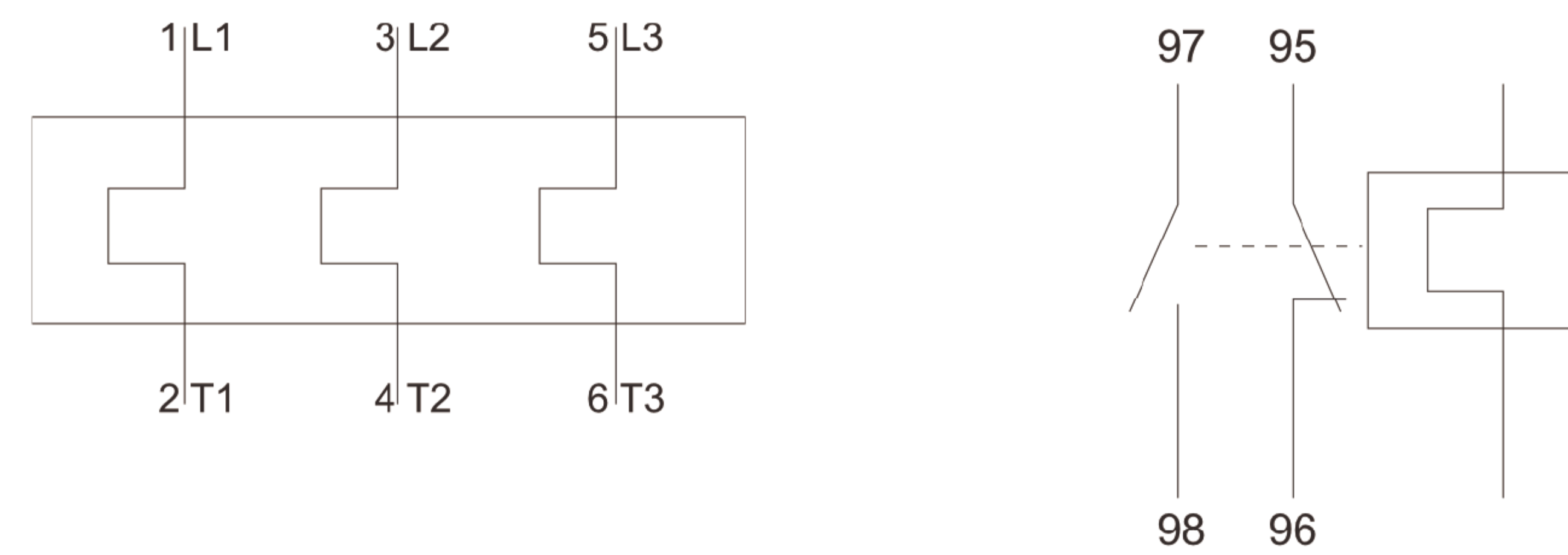

Instructions for Use
CQR2 Series Thermal Overload Relay Panel Symbols and Functional Button Description

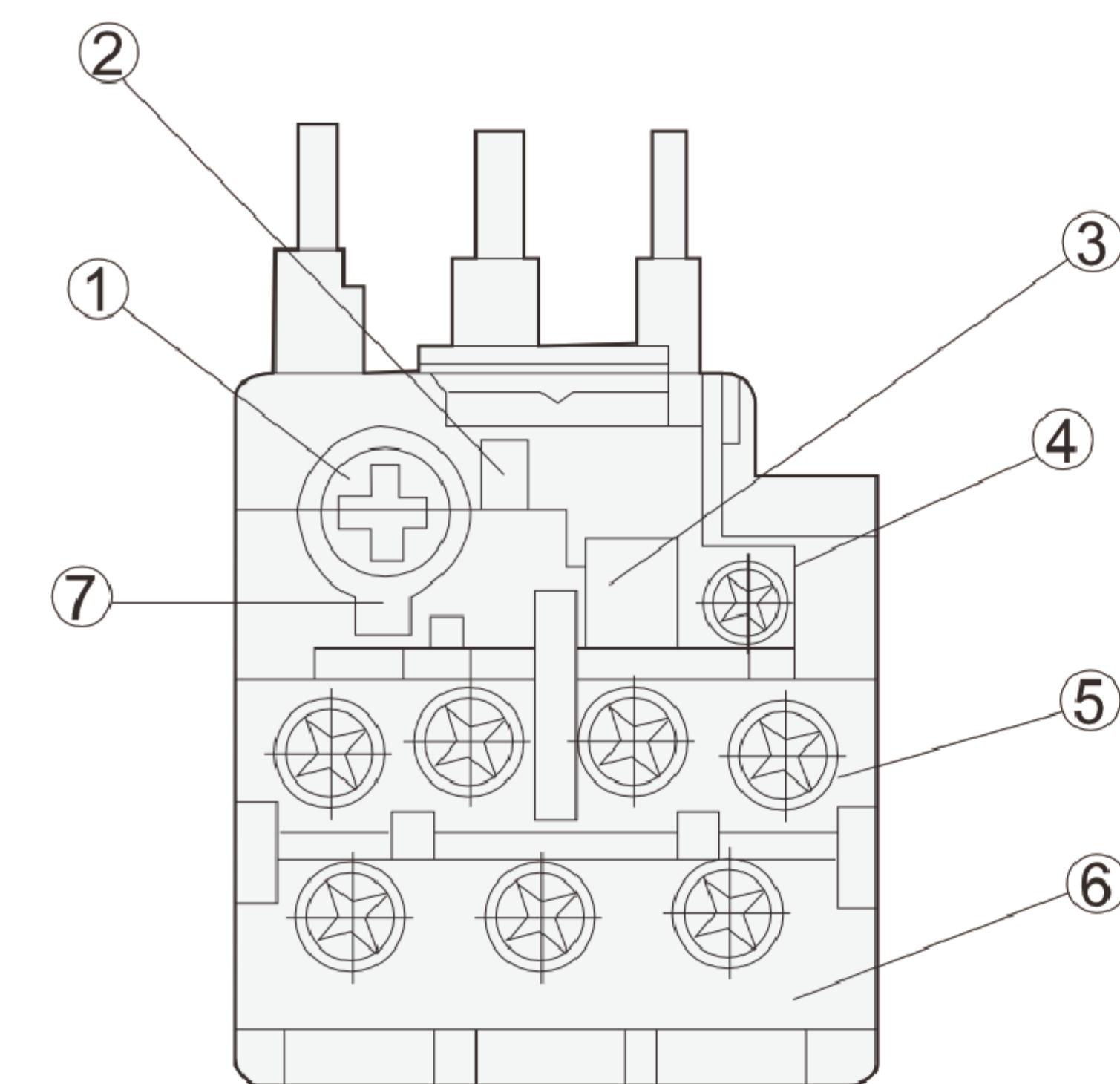

- ① Setting Current Adjustment Knob
- ② Trip Indication
- ③ Stop Button
- ④ Reset Button: A (Auto Reset) / H (Manual Reset)
- ⑤ Auxiliary Contact Terminals: 95, 96, 97, 98
95, 96: Normally Closed (NC) Contacts
97, 98: Normally Open (NO) Contacts
- ⑥ Main Circuit Terminal Numbers
- ⑦ Test Button

Trip Test (Performed BEFORE energizing the main circuit):

Open the cover. Press the test button with a screwdriver. The NC contacts will open and the NO contacts will close. The status change can be observed through the indicator window (yellow mark visible indicates tripped state; mark hidden indicates reset state - see illustration above).

Reset Mode Setting (Performed BEFORE energizing the main circuit):

The relay leaves the factory set to manual reset mode. To select automatic reset mode, press and hold the reset button while turning it clockwise 90°. It is not advisable to change the reset mode while the circuit is energized and running.





Setting Current Adjustment (Performed BEFORE energizing the main circuit):

The relay leaves the factory set to the minimum setting current. To select a different setting current value, open the cover and turn the current setting dial with a screwdriver. Align the arrow on the dial with the current value corresponding to the full-load rated current of the motor being protected.

Emergency Stop:

Press the Stop Button. Pressing the stop button only opens the NC contacts; it does not affect the NO contacts. Releasing the stop button resets the NC contacts.

Accessories Description

Application	Model number	Application
	MB-1	Combined with M12 to form an independent mounting product
	MB-2	Combined with M25 to form an independent mounting product
	MB-3	Combined with M38 to form an independent mounting product
	MB-4	Combined with M95 to form an independent mounting product

Dimensions (mm)

CQR2-25

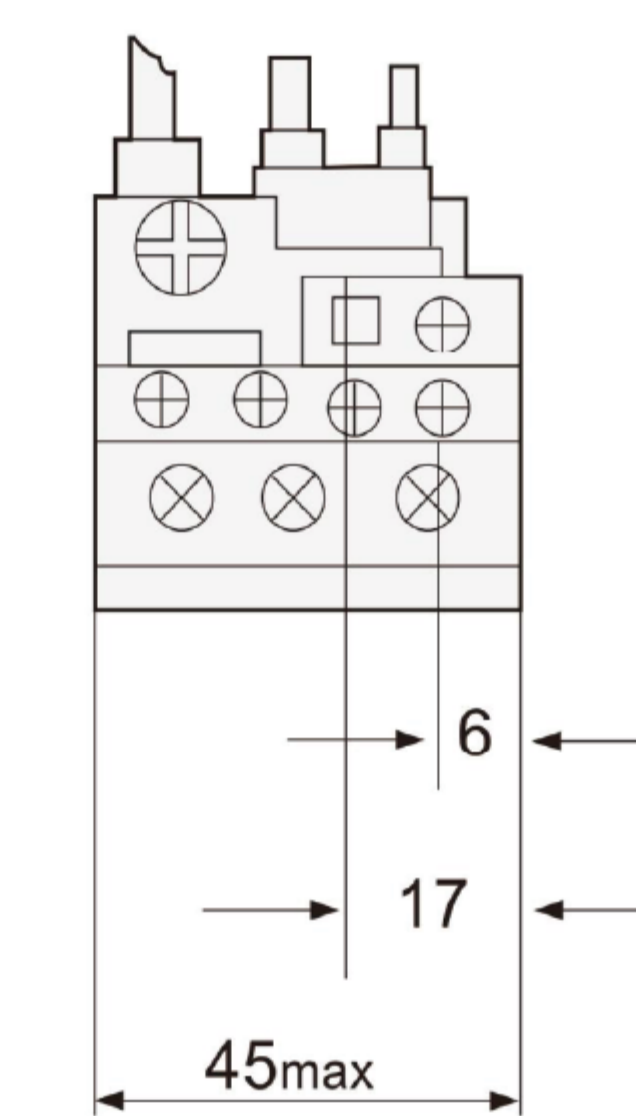
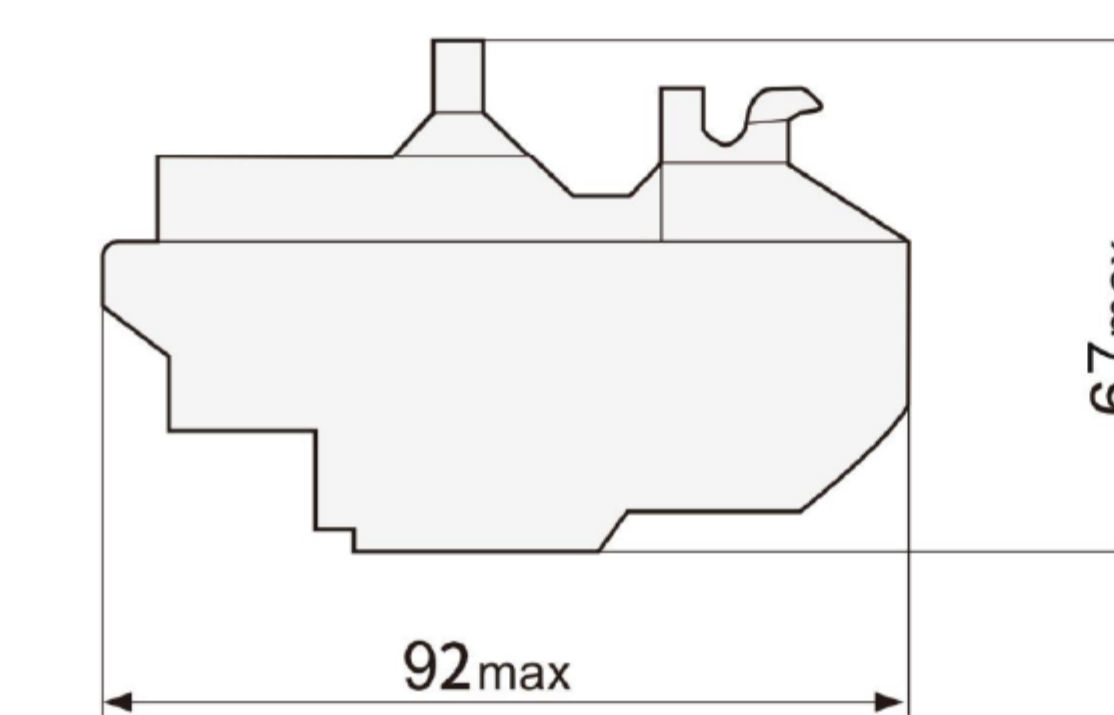

CQR2-38

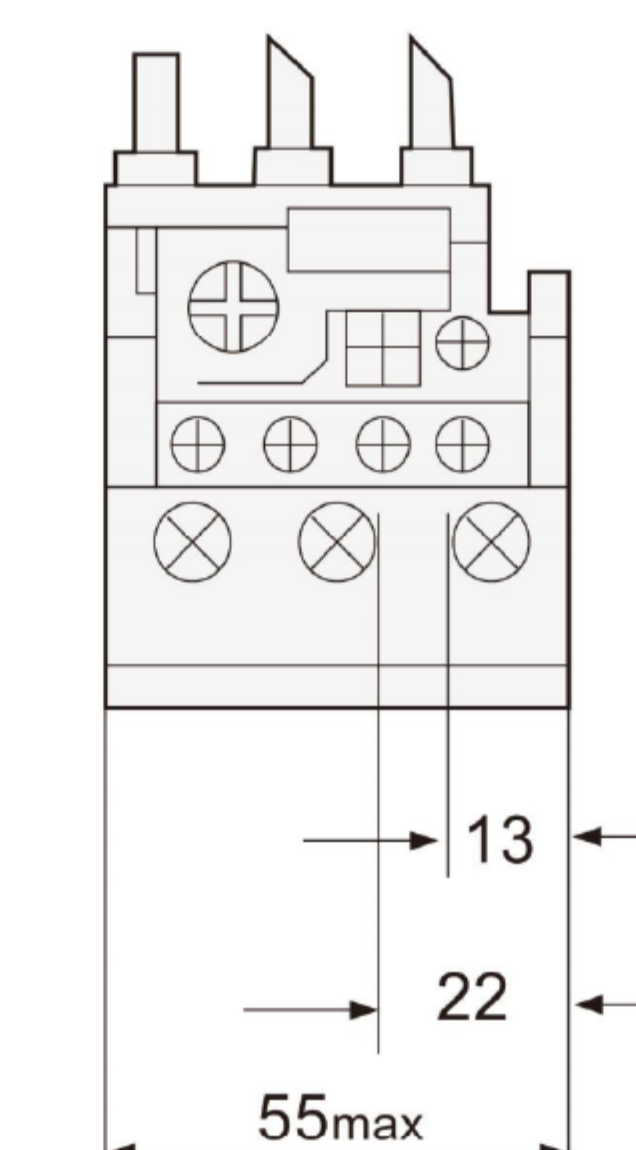
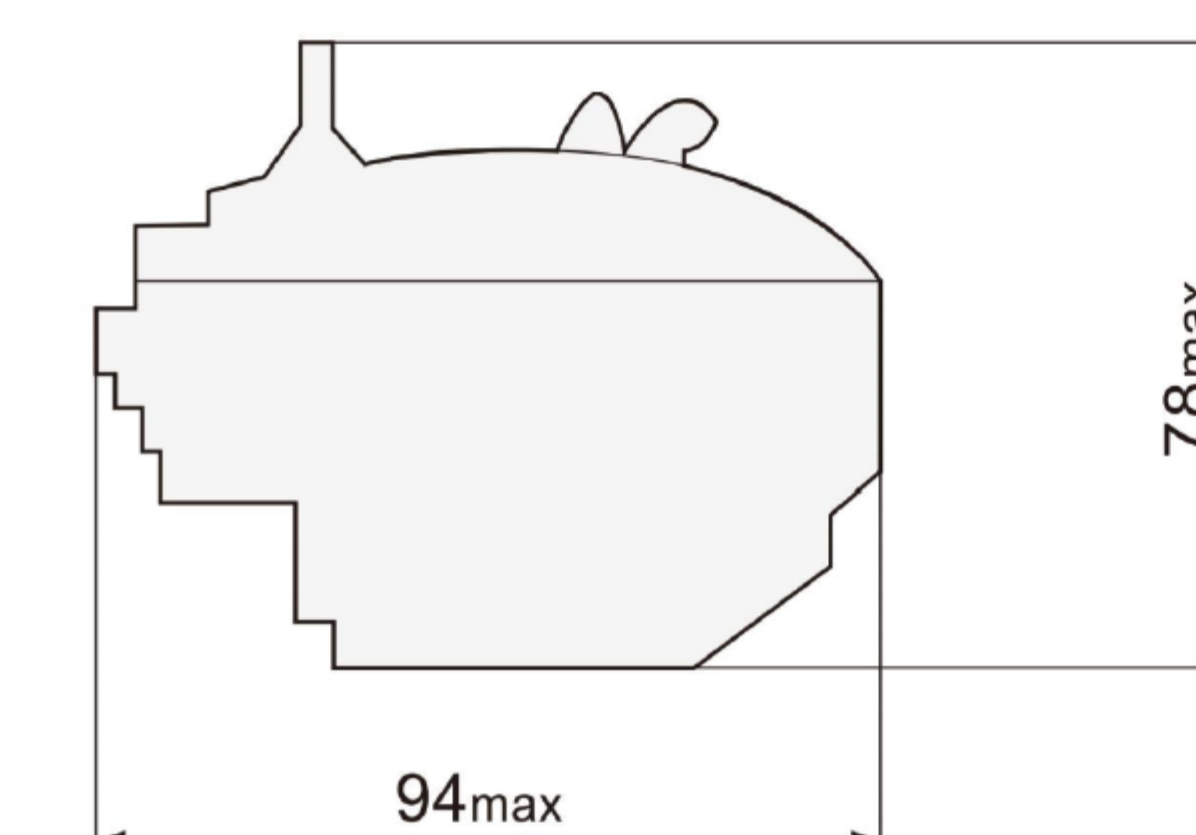

CQR2-95

