

CHAC

STE Series High Voltage DC Contactor

PRODUCT CATALOG



ZHEJIANG CHUANGQI ELECTRIC CO.,LTD.

- 🏠 Wenzhou Base
No. 18, Shahong Road, Beibaixiang Town, Yueqing City, Wenzhou, Zhejiang Province, China
- 🏠 Jiaxing Base
No. 61, Zhengyang West Road, Xiuzhou District, Jiaxing, Zhejiang Province, China
- ☎ 0577-27878806
- ✉ marketing@chac-en.com
- 🌐 www.chac-electric.com



LINKEDIN



WEBSITE

V2026.04-CHAC-MKT

STE1 Series

High-voltage DC contactor (Square Ceramic Sealing)



Product Features

- Advanced Sealing Technology
 - Square ceramic-encapsulated design, offering superior high-temperature resistance and corrosion protection for environments $\geq 1500\text{VDC}$.
- Ultra-High Voltage Support
 - Operating voltage range: 750VDC to 1800VDC (e.g., STE1-400).
- High-Current Handling
 - Rated current: 40A–600A; peak breaking capacity up to 2500A (at 300VDC).
 - Short-term overload endurance (e.g., STE1-600: 800A for 20 minutes).

Type designation

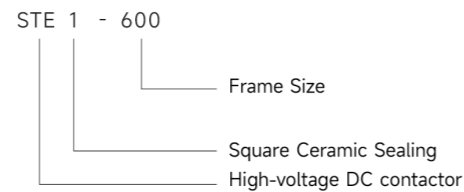

Product model	Working voltage	Working current	Load polarity	Coil polarity	Auxiliary contact
STE1-40	1500	40	Non-polarity	Non-polarity	/
STE1-60	1000	60	Non-polarity	Non-polarity	/
STE1-100	1000	100	Having polarity	Non-polarity	/
STE1-150	750	150	Non-polarity	Non-polarity	/
STE1-200	750	200	Having polarity	Non-polarity	/
STE1-L200	1000	200	Non-polarity	Non-polarity	1NO
STE1-L300	1000	300	Non-polarity	Non-polarity	1NO
STE1-X300	1000	300	Non-polarity	Non-polarity	/
STE1-300	1000	300	Having polarity	Having polarity	/
STE1-300D	1500	300	Non-polarity	Non-polarity	1NO
STE1-350	1500	350	Non-polarity	Having polarity	1NO
STE1-400	1500	400	Non-polarity	Non-polarity	1NO
STE1-600	1000	600	Having polarity	Having polarity	/

Technical Specifications

Product model		STE1-40	STE1-60
Contact form		1H	1H
Auxiliary contact		/	/
Contact polarit		Non-polarity	Non-polarity
Contact resistance		$\leq 5\text{m}\Omega$ (at 40A)	$\leq 5\text{m}\Omega$ (at 60A)
Operating voltage		$\leq 75\%U_n$	$\leq 75\%U_n$
Maximum breaking current		40A	60A
Electrical endurance		10~1500V	10~1000V
Maximum breaking current		400A(300VDC)	600A(300VDC)
Electrical endurance		≥ 300 times(40AV1500VDC)	$\geq 1 \times 10^4$ times(60A/750VDC) $\geq 5 \times 10^3$ times(60A/1000VDC)"
Current carrying		40A:Continuous for 60A:60min 160A:10s	60A:Continuous for 80A:20min 160A:40s
Dielectric withstand voltage	Between open contacts	3000VAC	3000VAC
	Between contact coils	4000VAC	4000VAC
Mechanical Endurance		2×10^5 times	2×10^5 times
Coil Voltage		12V,24V	12V,24V
Coil power consumption		3W	3W
Load extraction method		Internal thread	Internal thread
Coil lead out method		Connector	Connector
Weight		About 180g	About 180g
Vibrate		10Hz~500Hz 49m/s ²	10Hz~500Hz 49m/s ²
Humidity		5%~85%RH	5%~85%RH
Humidity range		-40°C~+85°C	-40°C~+85°C
External dimensions/mm		79.2×36.7×48	79.2×36.7×48

Note: 1.The above parameters are all initial values,measured at room temperature of 23°C.
2. Unless otherwise specified,the electrica durabilitytests are conductedon resistiveloads with a on/off ratio of 0.6s:5.4s.

Technical Specifications

Product model	STE1-100	STE1-150	STE1-200
Contact form	1H	1H	1H
Auxiliary contact	/	/	/
Contact polarit	Having polarity	Non-polarity	Having polarity
Contact resistance	≤1mΩ(at 100A)	≤5mΩ(at 150A)	≤0.5mΩ(at 200A)
Operating voltage	≤75%Un	≤75%Un	≤75%Un
Maximum breaking current	100A	150A	200A
Electrical endurance	10~1000V	10~750V	10~750V
Maximum breaking current	1000A(300VDC)	1500A(300VDC)	2000A(300VDC)
Electrical endurance	≥6×10 ³ times(100A/750VDC) ≥5×10 ³ times(100A/1000VDC)	≥1.5×10 ³ times(150A/450VDC) ≥500 times(150A/750VDC)	≥1×10 ³ times(200A/450VDC) ≥500 times(200A/750VDC)
Current carrying	100A:Continuous for 120A:2h 200A:10min	150A:Continuous for 180A:2h 225A:15min	200A:Continuous for 250A:15min 320A:5min
Dielectric withstand voltage	Between open contacts	3000VAC	3000VAC
	Between contact coils	4000VAC	4000VAC
Mechanical Endurance	2X10 ⁵ times	2X10 ⁵ times	2X10 ⁵ times
Coil Voltage	12V,24V	12V,24V	12V,24V
Coil power consumption	4.5W	4.5W	6W
Load extraction method	Copper bar connection	Copper bar connection	Internal thread
Coil lead out method	Connector	Connector	Connector
Weight	About 400g	About 400g	About 350g
Vibrate	10Hz~500Hz 49m/s ²	10Hz~500Hz 49m/s ²	10Hz~500Hz 49m/s ²
Humidity	5%~85%RH	5%~85%RH	5%~85%RH
Humidity range	-40°C~+85°C	-40°C~+85°C	-40°C~+85°C
External dimensions (mm)	81.5×40×78.3	81.5×40×78.3	81×39×70

Note: 1.The above parameters are all initial values,measured at room temperature of 23°C.
2. Unless otherwise specified,the electrica durabilitytests are conductedon resistiveloads with a on/off ratio of 0.6s:5.4s.

Technical Specifications

Product model	STE1-L;200	STE1-L300
Contact form	1H	1H
Auxiliary contact	1NO	1NO
Contact polarit	Non-polarity	Non-polarity
Contact resistance	≤0.5mΩ(at 200A)	≤0.3mΩ(at 300A)
Operating voltage	≤75%Un	≤75%Un
Maximum breaking current	200A	300A
Electrical endurance	10~1000V	10~1000V
Maximum breaking current	1000A(300VDC)	2000A(300VDC)
Electrical endurance	≥5×10 ³ times(200A/450VDC) ≥1×10 ³ times(200A/750VDC) ≥300 times(200A/1000VDC)	≥2×10 ³ times(300A/450VDC) ≥700 times(300A/750VDC) ≥300 times(300A/1000VDC)
Current carrying	200A:Continuous for 300A:30min 400A:5min	300A:Continuous for 450A:5min 600A:1min
Dielectric withstand voltage	Between open contacts	4000VAC
	Between contact coils	4000VAC
Mechanical Endurance	2X10 ⁵ times	2X10 ⁵ times
Coil Voltage	12V,24V	12V,24V
Coil power consumption	3w	4.5W
Load extraction method	Internal thread	Internal thread
Coil lead out method	lead wire	lead wire
Weight	About 185g	About 320g
Vibrate	10Hz~500Hz 49ms ²	10Hz~500Hz 49m/s ²
Humidity	5%~85%RH	5%~85%RH
Humidity range	-40°C~+85°C	-40°C~+85°C
External dimensions (mm)	71.8×36×51	83.4×48×63.5

Note: 1.The above parameters are all initial values,measured at room temperature of 23°C.
2. Unless otherwise specified,the electrica durabilitytests are conductedon resistiveloads with a on/off ratio of 0.6s:5.4s.

Technical Specifications

Product model	STE1-X300	STE1-300	STE1-300D
Contact form	1H	1H	1H
Auxiliary contact	/	/	1NO
Contact polarit	Non-polarity	Having polarity	Non-polarity
Contact resistance	≤0.5mΩ(at 300A)	≤0.2mΩ(at 300A)	≤0.3mΩ(at 300A)
Operating voltage	≤75%Un	≤75%Un	≤75%Un
Maximum breaking current	300A	300A	300A
Electrical endurance	10~1000V	10~1000V	10~1500V
Maximum breaking current	2000A(300VDC)	2500A(300VDC)	2000A(300VDC)
Electrical endurance	≥1×10 ³ times(300AV450VDC) ≥500 times(300A750VDC) ≥100 times(300AV1000VDC)	≥6×10 ³ times(300A750VDC) ≥3×10 ³ times(300AV1000VDC)	≥1.4×10 ³ times(250A/800VDC) ≥1×10 ³ times(400A/1000VDC) ≥500 times(400A/1500VDC)
Current carrying	300A:Continuous for 450A:5min 600A:2min	300A:Continuous for 600A:1min 900A:10s	400A:Continuous for 600A:1h 800A:10min
Dielectric withstand voltage	Between open contacts	3000VAC	3000VAC
	Between contact coils	3000VAC	4000VAC
Mechanical Endurance	2X10 ⁵ times	2X10 ⁵ times	2X10 ⁵ times
Coil Voltage	12V,24V	12V,24V	12V,24V
Coil power consumption	6W	Connect 46Wand maintain 4.5W	10W
Load extraction method	Internal thread	Copper bar connection	Internal thread
Coil lead out method	Connector	Connector	Connector
Weight	About 370g	About 850g	About 700g
Vibrate	10Hz~500Hz 49m/s ²	10Hz~500Hz 49m/s ²	10Hz~500Hz 49m/s ²
Humidity	5%~85%RH	5%~85%RH	5%~85%RH
Humidity range	-40°C~+85°C	-40°C~+85°C	-40°C~+85°C
External dimensions (mm)	88.3×42.5×74.5	112.6×64.7×83.9	98.4×45×91.5

Note: 1.The above parameters are all initial values,measured at room temperature of 23°C.
2. Unless otherwise specified,the electrica durabilitytests are conductedon resistiveloads with a on/off ratio of 0.6s:5.4s.

Technical Specifications

Product model	STE1-350	STE1-400	STE1-600
Contact form	1H	1H	1H
Auxiliary contact	1NO	1NO	/
Contact polarit	The coil has polarity while the contacts have no polarity	Non-polarity	Having polarity
Contact resistance	≤0.3mΩ(at 350A)	≤0.2m(at 400A)	≤0.2mΩ(at 600A)
Operating voltage	≤75%Un	≤75%Un	≤75%Un
Maximum breaking current	400A	400A	600A
Electrical endurance	10~1500V	10~1800V	10~1500V
Maximum breaking current	2000A(300VDC)	2500A(300VDC)	2500A(300VDC)
Electrical endurance	≥100 times(150A/1800VDC) ≥1×10 ³ times(400A/1000VDC) ≥500 times(400A/1500VDC)	≥100 times(150A/1800VDC) ≥1×10 ³ times(400A/1000VDC) ≥500 times(400A/1500VDC)	≥1×10 ³ times(600A/750VDC) ≥500 times(600A/1000VDC) ≥100 times(600A/1500VDC)
Current carrying	400A:Continuousfor 450A:60min 600A:2min	400A:Continuous for 450A:10min 600A:90s	600A:Continuous for 800A:20min 1000A:5min
Dielectric withstand voltage	Between open contacts	4000VAC	4000VAC
	Between contact coils	4000VAC	4000VAC
Mechanical Endurance	2X10 ⁵ times	2X10 ⁵ times	2X10 ⁵ times
Coil Voltage	12V,24V	12V,24V	12V,24V
Coil power consumption	Connect 46W and maintain4.5W	10W	Connect 50W and maintain 10W
Load extraction method	Internal thread	Internal thread	Internal thread
Coil lead out method	Connector	Connector	lead wire
Weight	About 730g	About 850g	About 1020g
Vibrate	10Hz~500Hz 49m/s ²	10Hz~500Hz 49m/s ²	10Hz~500Hz 49m/s ²
Humidity	5%~85%RH	5%~85%RH	5%~85%RH
Humidity range	-40°C~+85°C	-40°C~+85°C	-40°C~+85°C
External dimensions (mm)	104×65×97.4	108×67×101.6	194.4×66.8×121.5

Note: 1.The above parameters are all initial values,measured at room temperature of 23°C.
2. Unless otherwise specified,the electrica durabilitytests are conductedon resistiveloads with a on/off ratio of 0.6s:5.4s.

STE2 Series

High-voltage DC contactor (Round Epoxy Sealing)

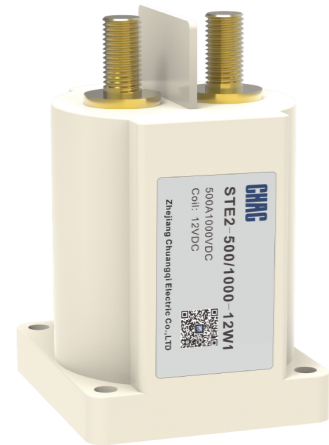

Product Features

- **Reliable Encapsulation**
 - Round epoxy-sealed construction, ensuring IP-rated dust/water resistance for industrial applications.
- **Wide Operating Range**
 - Voltage: 12-1500VDC; current: 50-800A (e.g., STE2-800: 1000VDC/800A).
 - Fully non-polarized load support.
- **Harsh-Environment Ready**
 - Operating temperature: -45°C to +85°C; humidity: 5-95% RH.
- **Extended Electrical Life**
 - Electrical endurance: 100,000 cycles (e.g., STE2-500 at 750VDC/500A).
 - Low coil consumption (≤6W for most models).
- **Easy Installation**
 - External-thread terminals (STE2-150+) for rapid wiring.

Type designation

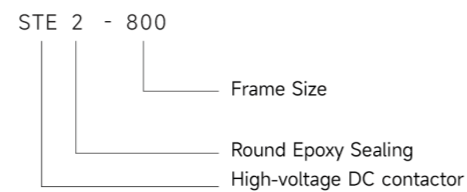

Product model	Working voltage	Working current	Load polarity	Coil polarity	Auxiliary contact
STE2-50	1500	50	Non-polarity	Non-polarity	/
STE2-100	1500	100	Non-polarity	Non-polarity	/
STE2-150	1500	150	Non-polarity	Non-polarity	/
STE2-200	1500	200	Non-polarity	Non-polarity	1NO
STE2-250	1500	250	Non-polarity	Non-polarity	1NO
STE2-300	1500	300	Non-polarity	Non-polarity	1NO
STE2-400	1500	400	Non-polarity	Non-polarity	1NO
STE2-500	1500	500	Non-polarity	Non-polarity	1NO
STE2-600	1500	600	Non-polarity	Non-polarity	1NO
STE2-800	1000	800	Non-polarity	Non-polarity	1NO

Technical Specifications

Product model	STE2-50	STE2-100	
Contact form	1H	1H	
Auxiliary contact	/	NO	
Contact polarity	Non-polarity	Non-polarity	
Contact resistance	≤1mΩ(at 50A)	≤1mΩ(at 100A)	
Operating voltage	≤75%Un	≤75%Un	
Maximum breaking current	50A	100A	
Electrical endurance	12-1500V	12-1500V	
Maximum breaking current	500A(320V DC)	1000A(320V DC)	
Electrical endurance	≥1×10 ⁵ times(50A/750VDC) ≥400 times(20A/1000VDC) ≥150 times(10A/1500VDC)	≥2×10 ⁵ times(100A/750VDC) ≥1×10 ⁵ times(100A/1000VDC) ≥600 times(15A/1500VDC)	
Current carrying	50A:Continuous for 100A:10min 200A:50s	100A:Continuous for 150A:10min 300A:50s	
Dielectric withstand voltage	Between open contacts	3500VAC	3500VAC
	Between contact coils	3500VAC	3500VAC
Mechanical Endurance	2X10 ⁵ times	2X10 ⁵ times	
Coil Voltage	12V,24V	12V,24V,48V	
Coil power consumption	12V:5.5w 24V:6w	12V:5.5w 24V:6.0w	
Load extraction method	Internal thread	Internal thread	
Coil lead out method	lead wire	lead wire	
Weight	About 115g	About 160g	
Vibrate	80Hz-2000Hz 49/s ²	80Hz-2000Hz 49/s ²	
Humidity	5%-95%RH	5%-95%RH	
Humidity range	-45°C~+85°C	-45°C~+85°C	
External dimensions (mm)	51.6X35.6X43.2	53.8X35.6X58.5	

Note: 1.The above parameters are all initial values,measured at room temperature of 23°C.
2. Unless otherwise specified,the electrica durabilitytests are conductedon resistiveloads with a on/off ratio of 0.6s:5.4s.

Technical Specifications

Product model	STE2-150	STE2-200	STE2-250
Contact form	1H	1H	1H
Auxiliary contact	NO	NO	NO
Contact polarity	Non-polarity	Non-polarity	Non-polarity
Contact resistance	≤1mΩ(at 150A)	≤1mΩ(at 200A)	≤1mΩ(at 250A)
Operating voltage	≤75%Un	≤75%Un	≤75%Un
Maximum breaking current	150A	200A	250A
Electrical endurance	12-1500V	12-1500V	12-1500V
Maximum breaking current	1000A(320VDC)	2000A(320VDC)	2000A(320VDC)
Electrical endurance	≥2×10 ³ times(100A/750VDC) ≥1×10 ³ times(150A/1000VDC) ≥600 times(30A/1500VDC)	≥2×10 ³ times(200A/750VDC) ≥1×10 ³ times(200A/1000VDC) ≥1×10 ³ times(50A/1500VDC)	≥2×10 ³ times(250A/750VDC) ≥1×10 ³ times(250A/1000VDC) ≥1×10 ³ times(50A/1500VDC)
Current carrying	150A:Continuous for 180A:10min 300A:50s	200A:Continuous for 300A:10min 400A:180s	250A:Continuous for 300A:10min 400A:180s
Dielectric withstand voltage	Between open contacts	3500VAC	3500VAC
	Between contact coils	3500VAC	3500VAC
Mechanical Endurance	2X10 ⁵ times	2X10 ⁵ times	2X10 ⁵ times
Coil Voltage	12V,24V,36V,48V	12V,24V,36V,48V	12V,24V,36V,48V
Coil power consumption	12V,24,48V:5.76w 36V:2.5w	6w	6w
Load extraction method	External thread	External thread	External thread
Coil lead out method	lead wire	lead wire	lead wire
Weight	About 430g	About 430g	About 430g
Vibrate	80Hz-2000Hz 49/s ²	80Hz-2000Hz 49/s ²	80Hz-2000Hz 49/s ²
Humidity	5%-95%RH	5%-95%RH	5%-95%RH
Humidity range	-45°C~+85°C	-45°C~+85°C	-45°C~+85°C
External dimensions (mm)	53.8X35.2X59.5	80.5X63.6X73.8	80.5X63.6X73.8

Note: 1.The above parameters are all initial values,measured at room temperature of 23°C.
2. Unless otherwise specified,the electrica durabilitytests are conductedon resistiveloads with a on/off ratio of 0.6s:5.4s.

Technical Specifications

Product model	STE2-300	STE2-400
Contact form	1H	1H
Auxiliary contact	NO	NO
Contact polarity	Non-polarity	Non-polarity
Contact resistance	≤1mΩ(at 300A)	≤1mΩ(at 400A)
Operating voltage	≤75%Un	≤75%Un
Maximum breaking current	300A	400A
Electrical endurance	12-1500V	12-1500V
Maximum breaking current	2000A(320V DC)	2500A(320V DC)
Electrical endurance	≥2×10 ³ times(300A/750VDC) ≥1×10 ³ times(300A/1000VDC) ≥1×10 ³ times(80A/1500VDC)	≥3×10 ³ times(400A/750VDC) ≥1×10 ³ times(400A/1000VDC) ≥1×10 ³ times(200A/1500VDC)
Current carrying	300A:Continuous for 350A:10min 400A:180s	400A:Continuous for 500A:10min 600A:180s
Dielectric withstand voltage	Between open contacts	3500VAC
	Between contact coils	3500VAC
Mechanical Endurance	2X10 ⁵ times	2X10 ⁵ times
Coil Voltage	12V,24V,36V,48V	12V,24V,36V
Coil power consumption	6w	3w
Load extraction method	External thread	External thread
Coil lead out method	lead wire	lead wire
Weight	About 430g	About 990g
Vibrate	80Hz-2000Hz 49/s ²	80Hz-2000Hz 49/s ²
Humidity	5%-95%RH	5%-95%RH
Humidity range	-45°C~+85°C	-45°C~+85°C
External dimensions (mm)	80.5X63.6X73.8	66.6X78.1X104.5

Note: 1.The above parameters are all initial values,measured at room temperature of 23°C.
2. Unless otherwise specified,the electrica durabilitytests are conductedon resistiveloads with a on/off ratio of 0.6s:5.4s.

Technical Specifications

Product model		STE2-500	STE2-600	STE2-800
Contact form		1H	1H	1H
Auxiliary contact		NO	NO	NO
Contact polarit		Non-polarity	Non-polarity	Non-polarity
Contact resistance		≤1mΩ(at 500A)	≤1mΩ(at 600A)	≤1m(at 800A)
Operating voltage		≤75%Un	≤75%Un	≤75%Un
Maximum breaking current		500A	600A	800A
Electrical endurance		12-1500V	12-1500V	12-1500V
Maximum breaking current		2500A(320VDC)	2500A(320V DC)	2500A(320V DC)
Electrical endurance		≥2×10 ⁵ times(500A/750VDC) ≥1×10 ⁵ times(500A/1000VDC) ≥1×10 ⁵ times(250A/1500VDC)	≥2×10 ⁵ times(600A/750VDC) ≥1×10 ⁵ times(600A/1000VDC) ≥1×10 ⁵ times(300A/1500VDC)	≥600 times(800A/750VDC) ≥1×10 ⁵ times(450A/1000VDC) ≥200 times(350A/1500VDC)
Current carrying		500A:Continuous for 550A:10min 600A:180s	600A:Continuous for 650A:10min 700A:180s	800A:Continuous for 900A:10min1000A:120s
Dielectric withstand voltage	Between open contacts	3500VAC	3500VAC	3500VAC
	Between contact coils	3500VAC	3500VAC	3500VAC
Mechanical	Endurance	2X10 ⁵ times	2X10 ⁵ times	2X10 ⁵ times
Coil Voltage		12V,24V,36V	12V,24V,36V	12V,24V,36V
Coil power consumption		3w	3w	3w
Load extraction method		External thread	External thread	External thread
Coil lead out method		lead wire	lead wire	lead wire
Weight		About 990g	About 990g	About 990g
Vibrate		80Hz~2000Hz 49/s ²	80Hz~2000Hz 49/s ²	80Hz~2000Hz 49/s ²
Humidity		5%-95%RH	5%-95%RH	5%-95%RH
Humidity range		-45°C~+85°C	-45°C~+85°C	-45°C~+85°C
External dimensions (mm)		66.6X78.1X104.5	66.6X78.1X104.5	66.6X78.1X104.5

Note: 1.The above parameters are all initial values,measured at room temperature of 23°C.
2. Unless otherwise specified,the electrica durabilitytests are conductedon resistiveloads with a on/off ratio of 0.6s:5.4s.

STE3 Series High-voltage DC contactor (Round Ceramic Sealing)



Product Features

- Superior Protection
 - Ceramic sealing + polarized load design (all models), rated for 1000VDC
- High Surge Current Tolerance
 - Short-term withstand: e.g., STE3-250 handles 400A for 10min + 800A for 10s.
- Energy-Saving Operation
 - Coil power: 45W pickup / 2.8W holding(>75% energy reduction).
- Compact & Lightweight
 - Minimal footprint

Product model	Working voltage	Working current	Load polarity	Coil polarity	Auxiliary contact
STE3-50	1000	50	Having polarity	Non-polarity	/
STE3-100	1000	100	Having polarity	Non-polarity	/
STE3-150	1000	150	Non-polarity	Non-polarity	1NO
STE3-200	1000	200	Non-polarity	Non-polarity	1NO
STE3-250	1000	250	Non-polarity	Non-polarity	1NO
STE3-300	1000	300	Non-polarity	Non-polarity	1NO
STE3-350	750	350	Non-polarity	Non-polarity	1NO

Technical Specifications

Product model		STE3-50	STE3-100
Contact form		1H	1H
Auxiliary contact		/	/
Contact polarit		Having polarity	Having polarity
Contact resistance		≤3mQ(at 50A)	≤3mQ(at 100A)
Operating voltage		≤75%Un	≤75%Un
Maximum breaking current		50A	100A
Electrical endurance		10~1000V	10~1000V
Maximum breaking current		1000A(300VDC)	1000A(300VDC)
Electrical endurance		600 times(1000V,50A)	500 times(1000V,50A)
Current carrying		50A:Continuous for 200A:10min 300A:10s	100A:Continuous for 200A:10min300A:10s
Dielectric withstand voltage	Between open contacts	2500VAC	2500VAC
	Between contact coils	2500VAC	2500VAC
Mechanical	Endurance	2X10 ⁵ times	2X10 ⁵ times
Coil Voltage		12V,24V	12V,24V
Coil power consumption		5.5w	5.5w
Load extraction method		Intemal thread	Intemal thread and screw
Coil lead out method		lead wire	lead wire
Weight		About 180g	About 180g
Vibrate		10Hz~500Hz 49m/s ²	10Hz~500Hz 49m/s ²
Humidity		5%~85%RH	5%~85%RH
Humidity range		-40°C~+85°C	-40°C~+85°C
External dimensions (mm)		55.2X39.6X57.8	55.2X39.6X57.8

Technical Specifications

Product model	STE3-150	STE3-200	STE3-250
Contact form	1H	1H	1H
Auxiliary contact	NO	NO	NO,
Contact polarit	Having polarity	Having polarity	Having polarity
Contact resistance	≤1.5mΩat 150A)	≤1.5mΩ(at 200A)	≤1.5mΩ(at 250A)
Operating voltage	≤75%Un	≤75%Un	≤75%Un
Maximum breaking current	150A	200A	200A
Electrical endurance	10~1000V	10~1000V	10~1000V
Maximum breaking current	1600A(300VDC)	2000A(300VDC)	2000A(300VDC)
Electrical endurance	50 times(1000V,150A)	30 times(1000V,150A)	15 times(1000V,150A)
Current carrying	150A:Continuous for 400A:10min 800A:10s	200A:Continuous for 400A:10min 800A:10s	250A:Continuous for 400A:10min 800A:10s
Dielectric withstand voltage	Between open contacts	4000VAC	4000VAC
	Between contact coils	4000VAC	4000VAC
Mechanical Endurance	2X10 ⁵ times	2X10 ⁵ times	2X10 ⁵ times
Coil Voltage	12V,24V	12V,24V	12V,24V
Coil power consumption	Start 45w,maintain 2.8W	Start 45w,maintain 2.8W	Start 45w,maintain 2.8W
Load extraction method	External thread	External thread	External thread
Coil lead out method	lead wire	lead wire	lead wire
Weight	440g	440g	440g
Vibrate	10Hz ~ 500Hz 49m/s ²	10Hz ~ 500Hz 49m/s ²	10Hz ~ 500Hz 49m/s ²
Humidity	5% ~ 85%RH	5% ~ 85%RH	5% ~ 85%RH
Humidity range	-40°C~85°C	-40°C~85°C	-40°C~85°C
External dimensions (mm)	80.3×66×64.3	80.3×66×64.3	80.3×66×64.3

Note: 1.The above parameters are all initial values,measured at room temperature of 23°C.
2. Unless otherwise specified,the electrica durabilitytests are conductedon resistiveloads with a on/off ratio of 0.6s:5.4s.

Technical Specifications

Product model	STE3-300	STE3-350
Contact form	1H	1H
Auxiliary contact	NO	NO
Contact polarit	Having polarity	Having polarity
Contact resistance	≤1.5m(at 300A)	≤1.5m(at 350A)
Operating voltage	≤75%Un	≤75%Un
Maximum breaking current	300A	350A
Electrical endurance	10~1000V	10~1000V
Maximum breaking current	2000A(300VDC)	2000A(300VDC)
Electrical endurance	300A:Continuous for 400A:10min 600A:30s	350A:Continuous for 400A:10min 800A:10s
Current carrying	10 times(1000V,300A)	50 times(1000V,300A)
Dielectric withstand voltage	Between open contacts	3300VAC
	Between contact coils	3300VAC
Mechanical Endurance	2X10 ⁵ times	2X10 ⁵ times
Coil Voltage	12V,24V	12V,24V
Coil power consumption	Start 45w,maintain 2.8W	Start 45w,maintain 2.8W
Load extraction method	External thread	External thread
Coil lead out method	lead wire	lead wire
Weight	440g	440g
Vibrate	10Hz ~ 500Hz 49m/s ²	10Hz ~ 500Hz 49m/s ²
Humidity	5% ~ 85%RH	5% ~ 85%RH
Humidity range	-40°C~85°C	-40°C~85°C
External dimensions (mm)	80.3×66×64.3	80.3×66×64.3

Note: 1.The above parameters are all initial values,measured at room temperature of 23°C.
2. Unless otherwise specified,the electrica durabilitytests are conductedon resistiveloads with a on/off ratio of 0.6s:5.4s.

When the contactor is used in the changing circuit, a pre charging circuit should be added to keep the impulse current below the rated load current.

As shown in the figure, first close the main negative contactor, then close the pre charging contactor, and finally close the main positive contactor. If there is no pre charging circuit, transient high current will be generated at the moment of the main contactor closing, which may cause the main positive contactor to stick. Please be careful.

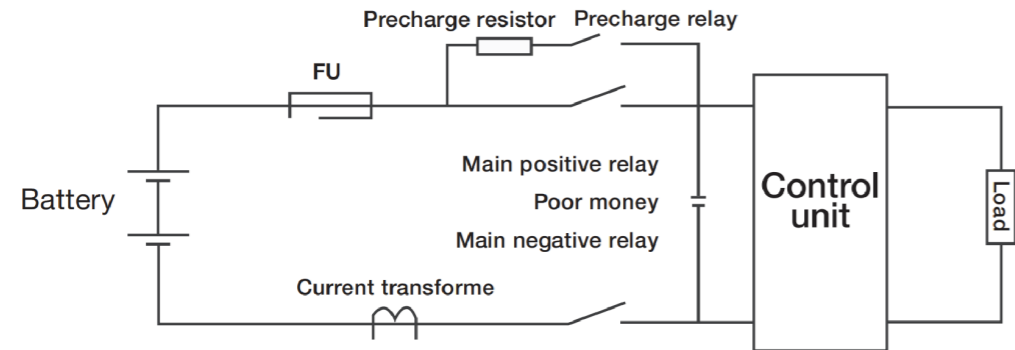

The rated values in the contact parameters are all values for resistive loads. When using an inductive load (Lload) with $L/R > 1ms$, please install surge absorbing elements in parallel at both ends of the inductive load. Without taking measures, it may cause a decrease in electrical lifespan and result in poor continuity.

The on/off reliability of the product may change under small loads due to environmental conditions and on/off frequency, so it needs to be confirmed under actual loads.

This contactor is a DC high-voltage opening and closing device. In the final fault state, there may be a situation where it cannot be turned on or off. Therefore, please do not use it beyond the capacity and frequency ranges specified in this manual. If it has reached the point where it cannot be connected or disconnected, it may lead to burning. A circuit structure that can cut off the current load in emergency situations should be adopted. To ensure safety, components should be replaced regularly.

For products that do not use coil drive boards or energy-saving versions, it is recommended to install nonlinear resistors (variable resistors are recommended) to suppress the reverse electromotive force of contactor coils. If diodes are used, the release time of the contactor will be greatly prolonged, which may lead to a decrease in cutting performance. Please be careful.

When conducting action voltage tests on products that use coil drive boards and energy-saving versions, the voltage should not slowly rise. Please use a fast rising edge (step power supply method) to drive the coil of the product, otherwise the contactor will not operate. At the same time, this type of product will automatically switch off current after about 0.3 seconds of connection, and repeated on/off operations within 0.3 seconds will cause contactor failure. Please be aware.

It is strictly prohibited to place the contactor in an environment that exceeds the product temperature range ($40^{\circ}C \sim +85^{\circ}C$) for a long time.

Please avoid installing near strong magnetic fields (transformers, magnets) and heating objects.

Ensure that the main power cord is closest to the outlet of the contactor. Then install and tighten in the order of flat washers, spring washers, and nuts. Incorrect connection sequence may cause severe overheating and lead to melting of the insulation layer of the connecting cable.

Please control the tightening torque of screws in each part within the specified range below. Beyond the range, it may cause damage to the ceramic sealing chamber and thread damage. In addition, the installation direction is not restricted.

Load outlet end		Product shell installation part	
M4	screws: 2Nm ~ 3Nm	M4	screws: 2Nm ~ 3Nm
M5	screws: 3Nm ~ 4Nm	M5	screws: 3Nm ~ 4Nm
M6	screws: 6Nm ~ 8Nm	M6	screws: 6Nm ~ 8Nm
M8	screws: 8Nm ~ 10Nm		

Please avoid sticking foreign objects such as grease on the lead out end; Please use the following specifications of connecting wires, otherwise it may cause abnormal heating of the lead out section.

Current/A	Nominal cross-sectional area of conductor/mm ²
10	≥1.5
20	≥4
30	≥6
40	≥10
50	≥16
60	≥16
100	≥35
150	≥70
200	≥95
250	≥150
300	≥185
350	≥240
400	≥300
500	≥370
600	≥480
800	≥600

The suction voltage and release voltage will change with the ambient temperature and usage conditions, so please pay attention!

If the coil and contacts are continuously energized using the rated voltage (current) and then cut off, and immediately re-energized, this contactor will experience an increase in coil resistance due to the temperature rise of the coil, resulting in an increase in the suction voltage and exceeding the rated suction voltage. At this time, please take the following measures to reduce the load current, limit the power on time, and apply a coil voltage that exceeds the rated voltage of the coil (quick start).

When opening and closing without load, the contact resistance may increase, so please be careful!

This product contains resin, so please do not use it in places or environments where gasoline, diluents, alcohol lamps, organic solvents, and strong alkaline substances such as ammonia and sodium hydroxide may be attached.

Please be careful not to attach grease or foreign objects to the load terminals, otherwise it may cause abnormal heating of the load terminals.