



# AC EV CHARGER

PEVC2201E/PEVC2201U

## User manual

# General

## Errors or inaccuracies

For any errors or inaccuracies thanks a lot, or to provide feedback and suggestions, send an email to [sinoevc@pmac.com.cn](mailto:sinoevc@pmac.com.cn).

## Product and environmental characteristics

AC EV Charger has been CE-certified by the manufacturer and bears the CE logo. The relevant declaration of conformity may be obtained from the manufacturer.

Electrical and electronic appliances, including accessories, must be disposed of separately from the general municipal solid waste. Recycling materials saves raw materials and energy and makes a major contribution to conserving the environment.

## Copyright

The ownership and all intellectual property rights of this user Manual, including but not limited to the content, data, and figures contained herein are vested by SINO. The Manual can only be applied to the operation or use of the product. Any disposition, duplication, dissemination, reproduction, modification, translation, extraction or any other usage of the Manual is prohibited without obtaining SINO prior written permission. As the product will be developed and improved continuously, SINO may modify or update the Manual from any time to time without any notice. SINO will do its best efforts to keep the Manual updated and maintain its accuracy of the Manual. SINO disclaims any kinds or forms of warranty, guarantee or undertaking, either expressly or implicitly, including but not limited to the completeness, accuracy, non-infringement, merchantability or fitness for particular purpose or usage.



## Safety and Warning

### Cautions

**Save these instructions. Read the manual before installation or usage of the device.**

- Do not put tools, materials or body parts into the electric vehicle connector.
- Do not use the AC EV charger if the cabinet, power cord or charging cable is frayed, has broken insulation or shows any other signs of damage.
- Do not install or use the AC EV charger if the enclosure is broken, cracked, opened or shows any other indications of damage.
- The AC EV charger should be installed only by a qualified technician.
- Make sure that the materials used and the installation procedures follow local building codes and safety standards.
- The information provided in this manual in no way exempts the user from responsibility to follow all applicable codes or safety standards.
- The manufacturer is not responsible for physical injury, damage to property or damage to the equipment caused by the installation of this device.
- This document provides instructions for the AC EV charger and should not be used for any other

- product. Before installation or use of this product, you should review this manual carefully and consult with a licensed contractor, licensed electrician or trained installation expert to make sure of compliance with local building codes and safety standards.

## Warnings

The input and output voltages of this device are high voltage, which threatens human life safety. Please strictly observe all warnings on the device and user manual. Unauthorized and non-professional service personnel are forbidden to remove the cover of this device.



Hazardous voltage that gives risk of electrocution



PE, Protective Earth



General risk



Do not extinguish the fire by means of water  
On all the electrical parts of the machine.



### CAUTION:

Not following the installation and user instructions given in this manual will result in the risk of electric shock, which will cause severe injury or death.

- Read this manual before installing or using the EV Charger.
- If you are unsure about how to install or use the AC EV Charger after reading this manual, Contact your reseller for more information.



### DANGER:

Installation, servicing, repair and relocation of this EV Charger by a non-qualified person will result in the risk of electric shock, which will cause severe injury or death.

- Only a qualified electrician is permitted to install, service, repair and relocate the EV Charger.
- The user must not attempt to service or repair the EV Charger as it does not contain user-serviceable parts.
- Local regulations may be applicable and may vary depending on your region / country of use. The qualified electrician must always ensure that the EV Charger is installed according to the local regulations.

## Remarks

- This EV Charger has been designed and tested in accordance with international standards.
- This EV Charger must be used exclusively for the purpose intended.
- These directions for use are valid for different models of the EV Charger. It is possible that several features described that may not apply to your EV Charger.
- Do not modify the EV Charger in any way. This will result in loss of warranty and liability, and may lead to dangerous circumstances.

**Note:**

Some electric vehicles require an external ventilation system to prevent the accumulation of hazardous or explosive gasses when charging indoors. Consult the vehicle is owner manual to determine whether or not your electric vehicle requires ventilation during charging. This EV Charger is not designed for charging these vehicles and must not be used for charging electric vehicles that require external ventilation.

## Transport and storage

Ensure that the main power source has been disconnected when storing or transporting the EV Charger. No liability can be accepted for damage during the transportation process if the EV Charger is transported in anything other than its original packaging. Store the EV Charger in a dry environment. The product is preferably stored at room temperature. If this is not possible, storage temperature must be between  $-40^{\circ}\text{C}$  and  $80^{\circ}\text{C}$  with a maximum humidity level of 95% non-condensing.

## Warranty and Service

### Customer Service

We can provide customers with professional product advice and purchase options. All emails will be responded to within 48 hours during working days. You can communicate with ease, or contact us through email anytime.

### After Service

The warranty of all our products is three years. The specific after-sale plan will be free for a replacement or charging a certain maintenance cost according to the specific situations. During the warranty period, customers can apply for replacement or free maintenance for the fault damage caused by product quality. For the fault damage caused by other reasons (human factors, natural factors, etc.), we will provide paid maintenance services.

### Contact Us

If you need to report for repair or inquire about charging product service, please call the company's customer service hotline at +86 756 6931888 ext 6056 or through the official email [sinoev@pmac.com.cn](mailto:sinoev@pmac.com.cn) contact us.

# CONTENTS

<b>1. Product Introduction</b> .....	<b>1</b>
1.1. Product Brief .....	1
1.2. Product Characteristics .....	2
<b>2. Product Technical</b> .....	<b>3</b>
2.1. Specifications .....	3
2.2. Dimension drawing .....	4
<b>3. Unpack Instructions</b> .....	<b>5</b>
3.1. Package Contents .....	5
3.2. Product Unpack .....	5
<b>4. Installation Instructions</b> .....	<b>7</b>
4.1. Moving & Storage .....	7
4.2. Safety Requirements .....	7
4.3. Installation Preparation .....	8
4.4. Personal Protective Equipment .....	9
4.5. Wiring Requirement .....	9
4.6. Grounding & Safety .....	9
4.7. Pre-installation Checklist .....	10
4.8. Wall Mounting Process .....	11
4.9. Column Mounting Process .....	13
<b>5. Operation Instructions</b> .....	<b>15</b>
5.1. Indicator Status .....	15
5.2. Power-on Checking .....	15
5.3. Networking Configuration .....	15
5.4. Start and stop charging by your charging card .....	15
5.5. Start and stop charging by your charging card .....	17
<b>6. Maintenance Instructions</b> .....	<b>19</b>
6.1. Error Codes .....	20
<b>7. Check List</b> .....	<b>21</b>
7.1. Check before power on .....	21
7.2. Check after powered .....	22

# 1. Product Introduction

## 1.1. Product Brief

The PEVC2201E/PEVC2201U is a basic AC EV Charger ,which include wall-mounting and column-mounting. Suitable for scenarios such as home and business. Easy to install and simple to operate. The shell is simple and elegant, the equipment performance is superior, and it has all-round protection functions. IP55 protection level, good dustproof and waterproof performance, Type A+6mA DC leakage protection, accurate measurement of charging data.Suitable for indoor and outdoor. Support a variety of charging modes, such as plug and play charging, swipe charging, APP charging, scan code charging. Compatible with Bluetooth/WiFi/Ethernet/4G and other communication functions.

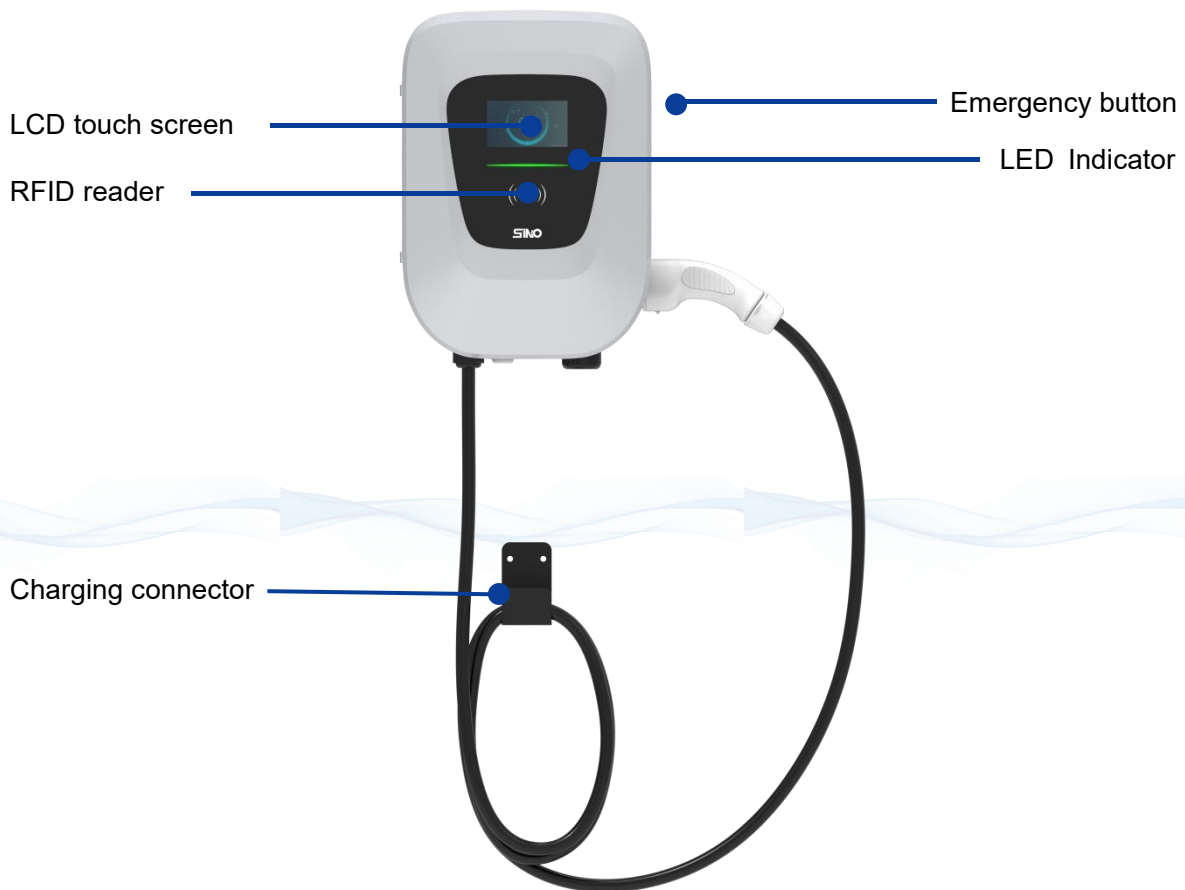

## 1.2. Product Characteristics

- **4.3 Inch LCD Display(Screen optional)**

The LCD screen can display the real-time charging status, including time, voltage, current, power and so on.

- **All-round protection**

Include voltage protection, current protection, leakage protection, temperature protection, lightning protection and other protective measures to ensure safety.

- **IP55, Strong and Durable**

Support outdoor harsh environment, waterproof and dustproof. The rugged shell which could resist the rolling and crash of the car.

- **High intelligence**

Powerful information collection, transmission and communication functions, supporting Bluetooth, Ethernet, 4G and WIFI wireless communication.

- **Easy to install and use**

The installation process is simple, payment is convenient and fast, supports mobile application software or IC card swiping. Fully compatible with almost all EVs on the market.

## 2. Product Technical

### 2.1. Specifications

Parameter Type	Description	PEVC2201E		PEVC2201U
Input	Power Supply	1P+N+PE	3P+N+PE	1P+N+PE
	Rated voltage	230VAC±10%	400VAC±10%	220VAC±10%
	Frequency	50/60Hz		
Output	Number of output ports	1		
	Voltage	230VAC±10%	400VAC±10%	220VAC±10%
	Rated Current	16A/32A		
	Power Rating	3.7kW/7.4kW	11kW/22kW	1.8kW/3.5kW/7kW
Safety	Electrical protection	Over/under voltage protection, Over current protection, Short circuit protection, Over/Under temperature protection, Lightning protection, ground protection		
	RCD	Type A + 6mA DC		
	Protection level	IP55		
	Impact protection	IK08		
	Certification	CE		
Environmental	Standards	IEC61851-1, IEC62196-1/2, SAE J1772-2017		
	Operating temperature	-30°C~+50°C		
	Storage temperature	-40°C~+80°C		
	Altitude	≤2000m		
Basic parameters	Humidity	≤95%, non-condensing		
	Energy meter	Accuracy Class 1 energy meter		
	HMI	4.3 inch LCD		
	Plug cable length	5m		
	Communication	Bluetooth/WiFi/ Ethernet/ 4G LTE		
	Protocol	OCPP-1.6J		
	Connector type	Type 2	Type 1	
	Installation method	Wall-mount/column-mount		
	Shell color	Metallic grey		
	Shell material	(ABC+PC)-Blend		
Start mode	Plug&play/RFID card/APP			



## 2.2. Dimension drawing

### Wall Mounting:

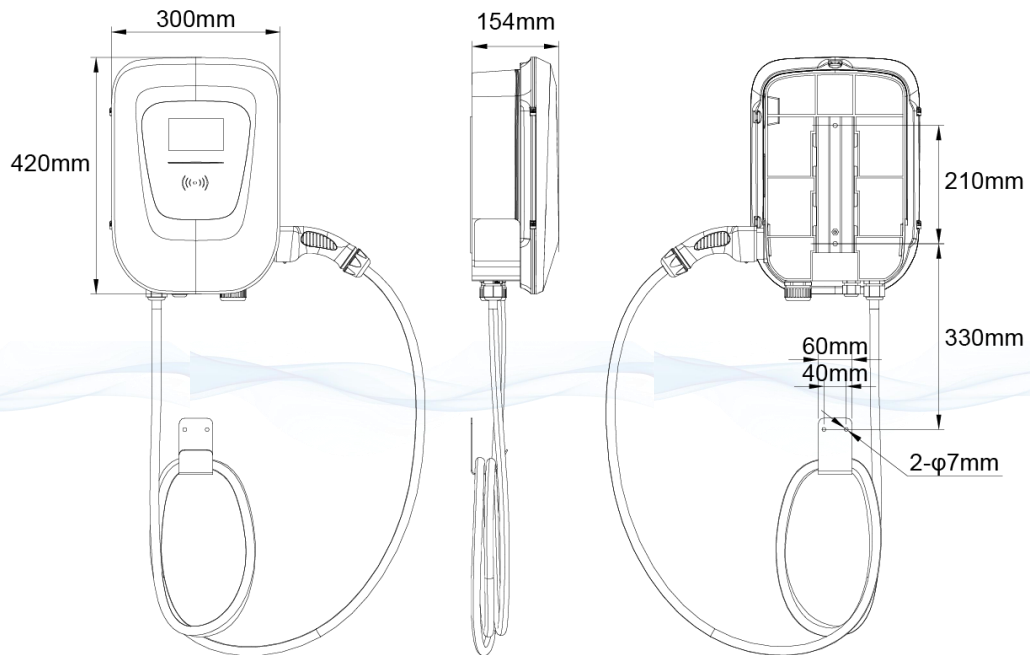

### Column Mounting:

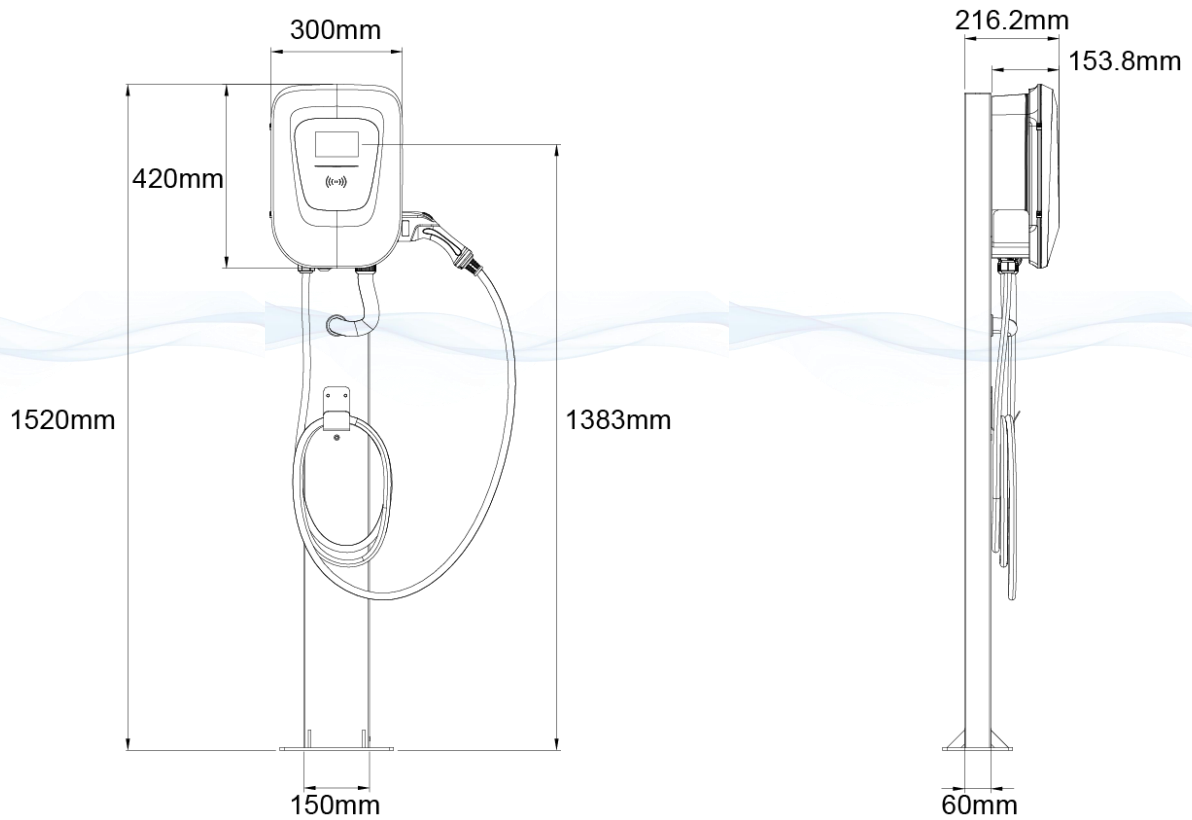







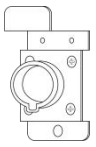

## 3. Unpack Instructions

### 3.1. Package Contents

Please check and verify the following items after receiving the charger :

- 1) Visual inspection of the charger's external appearance. If there is any breakage or other damage, please notify the seller immediately.
- 2) Check the type and quantity of all accessories as follows. If there is a shortage in the quantity of any item or if any items are missing, please contact the seller at once.

General parts					
					
User manual ( x1 )	RFID card ( x2 )	Certificate ( x1 )	Hook (x1)	bellows (x1)	Bracket(The bracket on the rear housing) (x1)
Wall Mounting	Column Mounting				
					
Expansion bolt M6×70 (x5)	Combination screw M6×20 (x5)	Expansion bolt M8×70 (x4)		Column ( Optional ) (x1)	

### 3.2. Product Unpack

**Unpack the product. Please check and verify the following items after receiving the charger:**

- 1) Move the EV Charger packaging to the installation area and place it flat on the ground.
- 2) Carefully cut the sealing tape on the packaging.
- 3) Remove the components box from the packaging.
- 4) Unpack the components box and check the components.
- 5) Lift out the charging cables and put them on the ground next to the box. Note: Place protective sheeting on the ground to protect the cables from damage by abrasion.
- 6) Remove the charging cable packaging.
- 7) Open the packaging and remove the filler material.

**WARNING:**

Do not leave the EV Charger standing unsecured. Secure the EV Charger to a support to make sure that it cannot fall. will cause injury and death.

**WARNING:**

Do not use the charging cables to lift or move the EV Charger. The cables can become damaged which will result in the risk of electric shock and damage to AC EV Charger, which will cause injury and death.

## 4. Installation Instructions

### 4.1. Moving & Storage

Obey the following guidelines when moving and storing EV Charger:

- Never lift AC EV Charger using its charging cables, connectors, covers or frame.
- Disconnect input power before removing the EV Charger for storage or relocation.
- Only transport and store the EV Charger in its original packaging. No liability can be accepted for damage incurred when the product is transported in non-standard packaging.
- Store the EV Charger in a dry environment in the temperature and humidity ranges given in the specifications.
- Please place it according to the direction of the package to avoid damaging the internal components during transportation.
- Keep dry during transportation, and goods cannot be stacked

The storage environment shall be kept dry, and shall not be placed in salt fog, humid environment, and shall not be stacked

### 4.2. Safety Requirements



Connecting and installing this product must be done by a qualified electrician. The owner or facility manager is responsible for the installation, operation, and maintenance of the EV Charger, whereby both the law regarding the safety of persons, animals, and property must be observed, as well as the installation instructions enforced in the country of use.









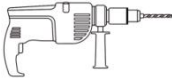

Read the safety instructions before you start working on the installation. Ensure the correct supply voltage/power and ensure that the meter cabinet is properly secured.

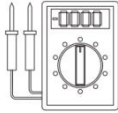
- Before shipment, each EV Charger is checked for correct connections and the EV Charger is operationally tested.
- Before switching on the EV Charger, check that the power source available corresponds to the configuration settings of the product as described in the manual.
- Check that all connectors are properly seated on the controller unit. (All stations are checked on this parameter before they leave our factories, but in rare instances, a connector can become loose or disconnected due to unforeseen transport conditions).
- Ensure that the equipment is used under the correct operating conditions.
- Never operate the product in wet, dusty, or explosive surroundings.
- Ensure that there is always adequate space surrounding the product for ventilation purposes.

### 4.3. Installation Preparation







Please prepare the following tools before installation :

 ( $\varnothing$ 22mm, 7/8 inch )			
Hammer drill	Electric drill	Multimeter	Hammer
			
Phillips screwdriver	Adjustable wrench	Diagonal Pliers	Measuring tape



#### Installation Notice:

- Electrical devices should only be installed, operated, and maintained by a qualified technician. No responsibility is assumed by the manufacturer for any consequences arising out of the use of this device.
- When installing wires, do not turn on the power supply.
- The length of the power cable and communication cable should be properly reserved to facilitate installation and connection.
- Pay attention to protecting the charger enclosure during installation to prevent bumping, scratching the surface, etc.
- The charging pile must be installed vertically, and the deviation of any direction from the vertical position should not exceed 5°.

### 4.4. Personal Protective Equipment

	Wear protective clothing 	Wear anti-static footwear 	Wear protective gloves 	Wear a face shield 	Wear ear protection 	Wear head protection 	Wear respiratory protection 
Transportation							
Handling							
Unpacking							
Assembly							
Ordinary use							
Adjustments							
Cleaning							
Maintenance							
Disassembling							
Dismantling							

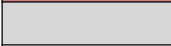
LEGEND

	PPE MANDATORY
	PRE-ENDED TO BE USED WHEN NECESSARY
	PPE NOT EXPECTED

### 4.5. Wiring Requirement

● **Ground Connection**

Always connect the Neutral at the service to Earth Ground. If the ground is not provided by the electrical service then a grounding stake must be installed nearby. The grounding stake must be connected to the ground bar in the main breaker panel and Neutral connected to the Ground at that point.



**DANGERS:**  
Beware of High Voltage

### 4.6. Grounding & Safety

The product must be connected to a grounded, metal, permanent wiring system. Connections shall comply with all applicable electrical codes.

- Ensure no power is connected at all times when installing, servicing, or maintaining the charger.
- Use the appropriate protection when connecting to the main power distribution network.
- Use appropriate tools for each task.



**CAUTION:**  
The disconnect switch for each ungrounded conductor of AC input shall be provided by the installation contractor or technician.

**CAUTION:**

A cord extension set or second cable assembly shall not be used in addition to the cable assembly for connection of the EV to the EV Charger.

#### 4.7. Pre-installation Checklist

- The conduits are laid and the correct gauge copper wires are used for installation.
- Cellular network connectivity at the location is good (Networked and RFID only).
- The current capacity of the site is already known (Amps).
- Required tools are available – we recommend a mini ratchet for tight areas.
- An electric vehicle or an EV Charger tester is available to complete the installation.
- The mounting option is selected and necessary provisions are made.
- All the units and accessories ordered are delivered, inspected, and free of damage.

## 4.8. Wall Mounting Process

- 1) Remove the screws: First remove the three screws (M4) on the rear housing, open the front cover, and then remove the internal screw (M6).

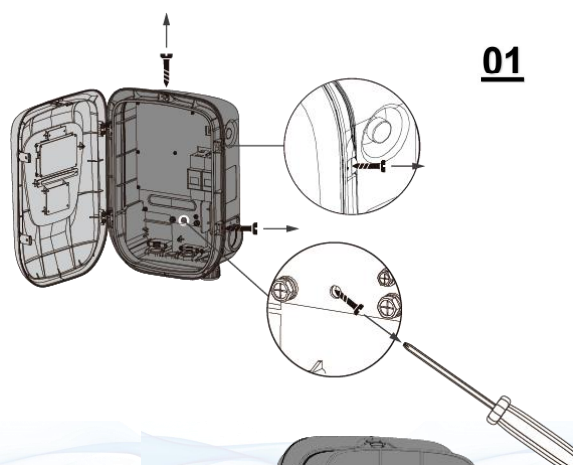
**01**

- 2) Remove the bracket on the rear housing.

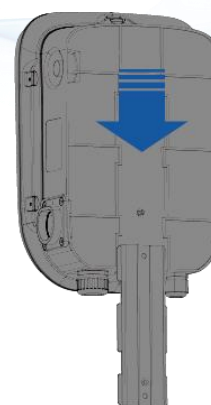
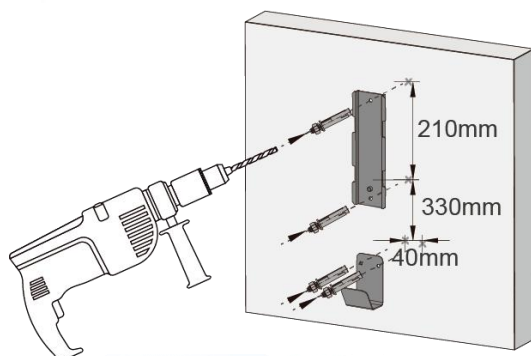
**02****03**

- 3) Use the bracket and hook to mark drill holes, place the anchors and fix the bracket and hook to the wall with nuts (x4).

- 4) Hang the charger station on its bracket from top to down, open the station cover, tighten the screw connected to bracket's stud.

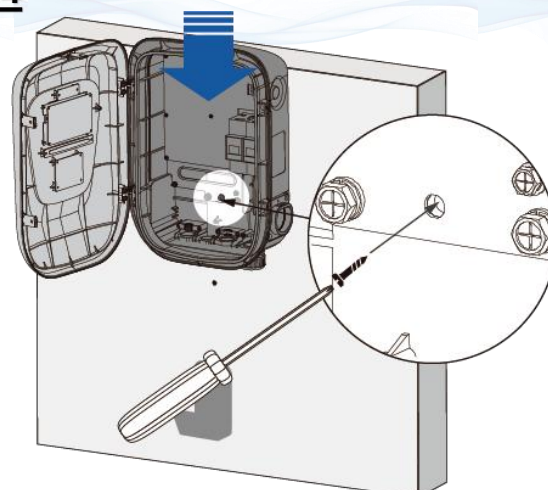
**04**

- 5) Pass the power cable through the bigger cable gland, crimp power terminal from the end of the power cable to be connected to the internal circuit breaker. Connect the ground wire (PE), neutral wire (N) and each phase (L) to the AC input configuration board. **Suggested input wire size 10mm<sup>2</sup>. Certified Circuit Breakers should be installed upstream close to the charging station, or build in RCD. Circuit breaker, if any, shall comply with standard with IEC 60898-1 or IEC 60947-2 or IEC 61009-1. All these protection**

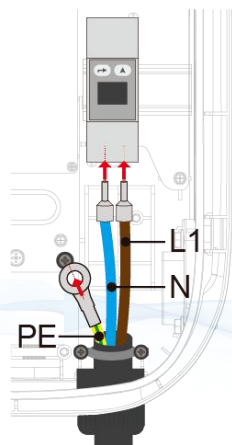
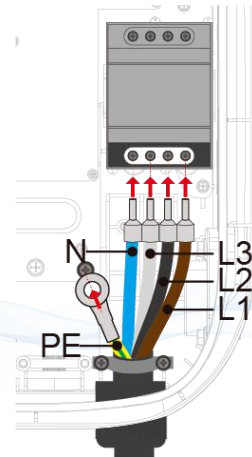

devices shall be chosen with appropriated technical specification, ie working voltage  $\geq$  charging station working voltage, working current  $\geq$  charging station working current, Ingress Protection (IP)  $\geq$  IP54 or installed inside IP54 protection box for outdoor use.

**05****1P+N+PE****3P+N+PE**

- 6) Close the charger station cover, tighten the side screws(x3).

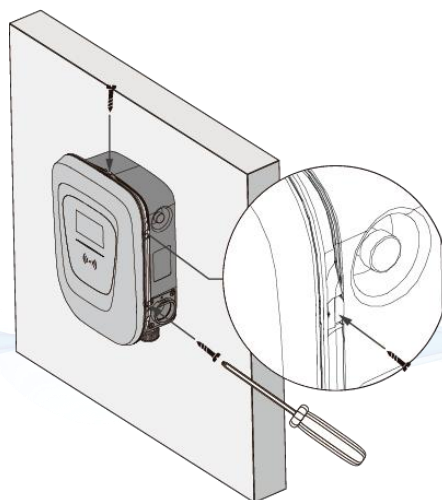
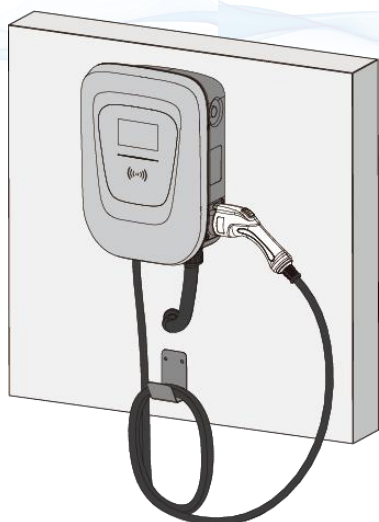
**06****08**

- 7) Complete installation and start to test and charge.

## 4.9. Column Mounting Process

- 1) Remove the screws: First remove the three screws (M4) on the rear housing, open the front cover, and then remove the internal screw (M6).

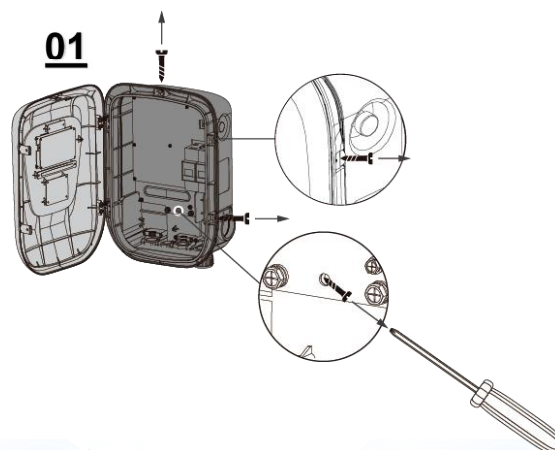

**02**

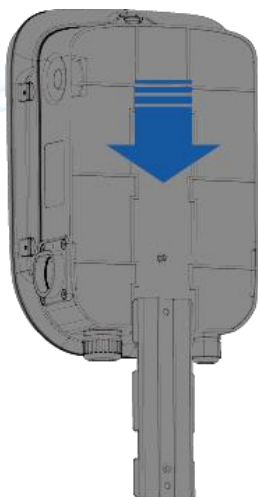

- 2) Remove the bracket on the rear housing

- 3) Make concrete platform

Then, mark the holes position of installation column and drill holes.

**03**

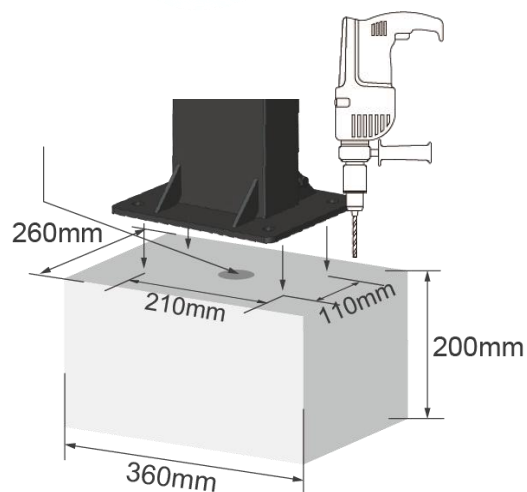

**04**

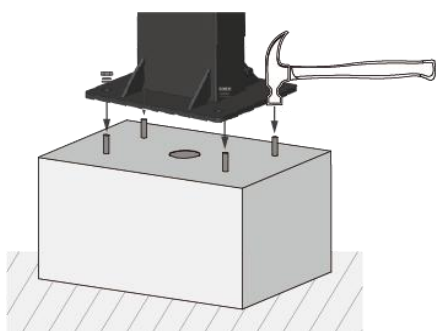

Install the bracket on the column.

- 4) Install expansion bolts in the base mounting holes. Fix the column on the concrete platform with expansion bolts(x4).

**05**

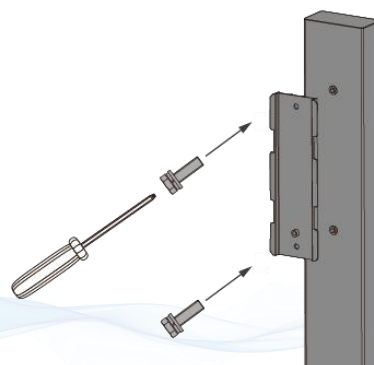

- 5) Install the column

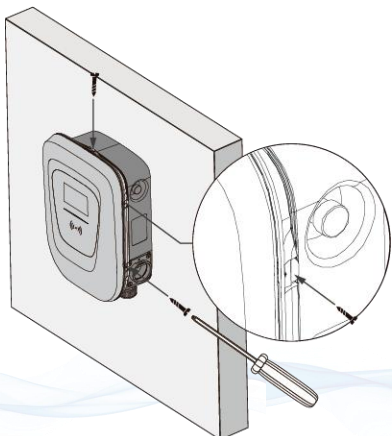
**06**

- 6) Hang the charger station on its bracket from top to down, open the station cover, tighten the screw connected to bracket's stud.

- 7) Refer to wall mounting wiring instruction.

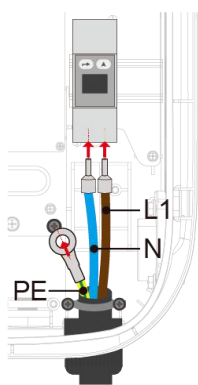
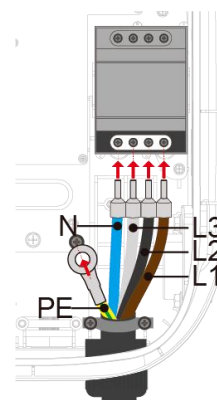
**07****1P+N+PE****3P+N+PE**

- 8) Close the charger station cover, tighten the side screws(x2).

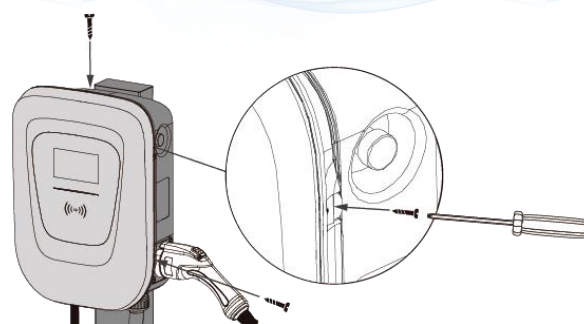
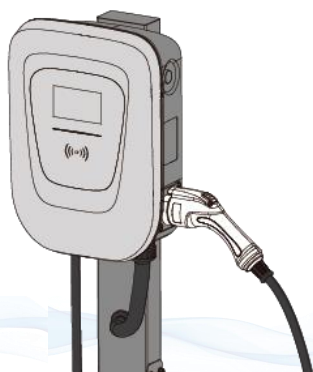
**08****09**

- 9) Complete installation and start to test and charge.

## 5. Operation Instructions

### 5.1. Indicator Status

	LED Light Status	Description of Charging status
	Green	Standby state
	Blue Blinking	Ready state
	Blue	Charging state
	Green/Blue Blinking	Charging stop
	Red	Error state

### 5.2. Power-on Checking

Please check / re-check the following items before initial Power-on:

- 1) The location of the charger should be convenient for operation and maintenance.
- 2) Before installation of the charger, ensure that the AC input component in the power supply is properly installed with the required protection.
- 3) Double confirm the charger is installed properly.
- 4) No components or other items have been left inside of the charger.

### 5.3. Networking Configuration

The smart EV Charger is equipped with an RFID card reader, and a Bluetooth/WiFi/ Ethernet/ 4G LTE communication module. These components together provide the authorization and communication of the charging session procedure with the central system (back-office) for processing and settlement of the transactions as required.

### 5.4. Start and stop charging by your charging card

- **Start charging**

- 1) Plug charger gun into EV car and LED light turn to blue flash.
- 2) Hold your RFID card in front of the reader, waiting 3 seconds.

- **Stop charging**

- 3) Waiting LED light turns to blue-green light flashing alternately, hold your charge card (RFID Card) in front of the reader, waiting 3 seconds.
- 4) The buzzer rings, unplug the charging cable from your car and place the charging cable back into the cable holder.
- 5) LED light turns to green breathing state, equipment returns to idle state.

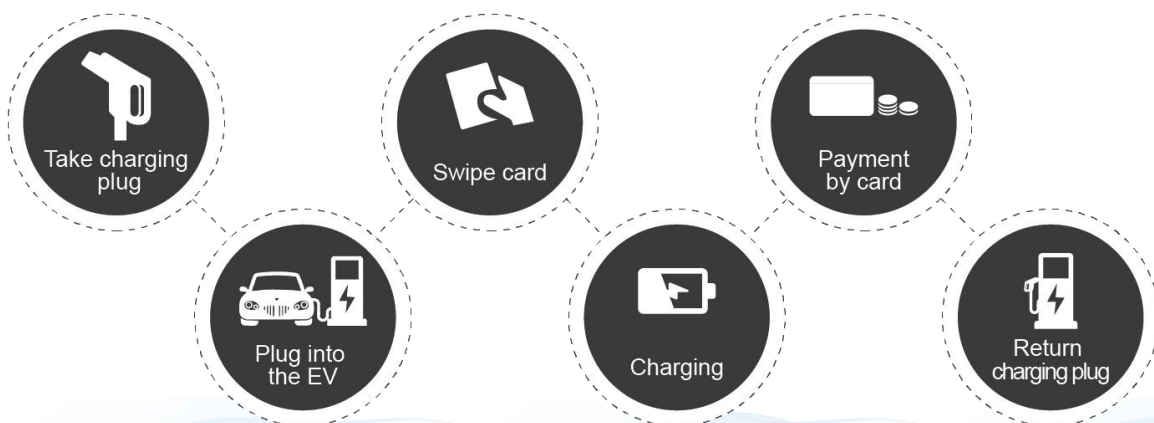

## 5.5. Start and stop charging by your charging card

- 1) Download the "SION ENERGY" APP either by scanning the QR code or from the Apple / Android App Store.
- 2) Turn on the phone's Bluetooth. Click the Add new device icon to enter the search page. If you have used it before, you can click the head directly to select the device to connect.



- 3) After entering the search page, find the available Bluetooth devices, and then click connect icon.
- 4) If the connection is successful, it will return to the home page to display the charging information.

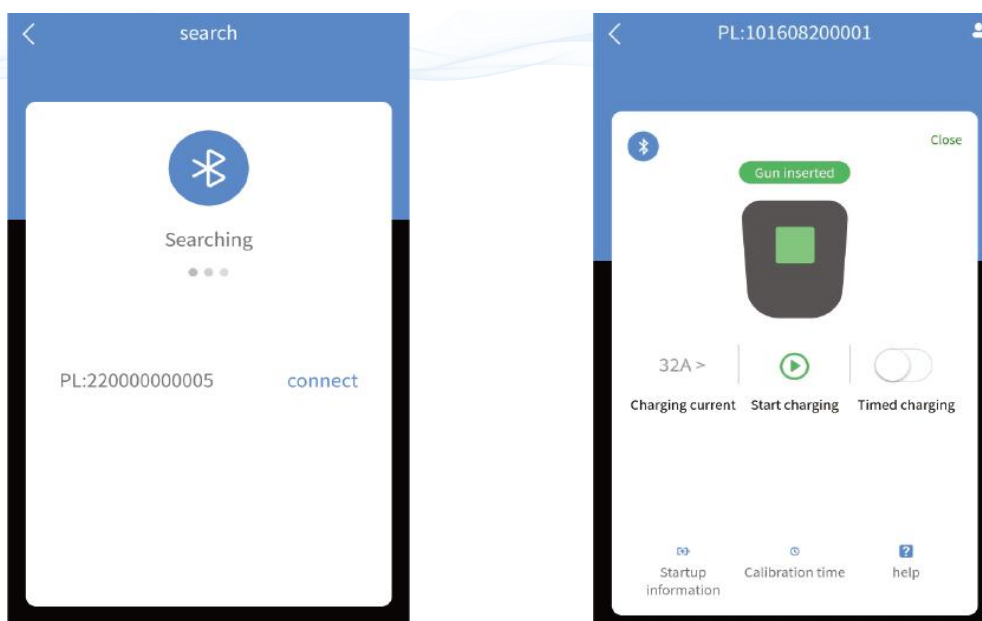

- 5) Connect your EV car with the charger gun.
- 6) Click the start charging con and start charging.

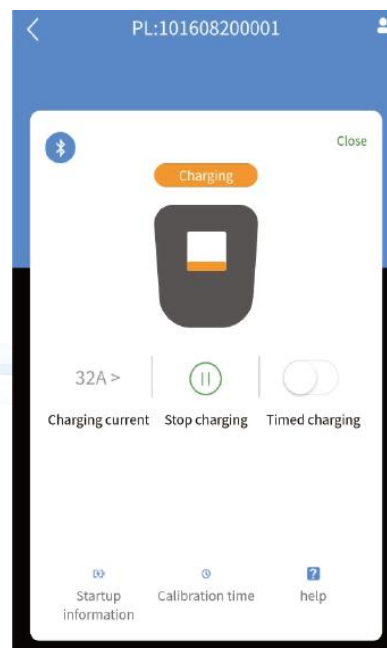
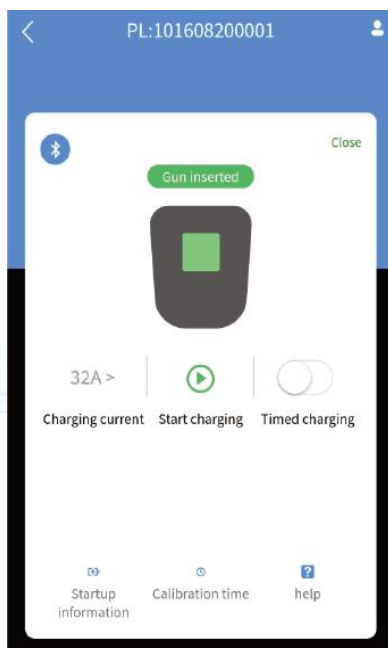

- 7) Click the startup information icon, which can display real-time charging information.
- 8) Click the stop charging icon will stop charging, then unplug the gun to complete the charging.

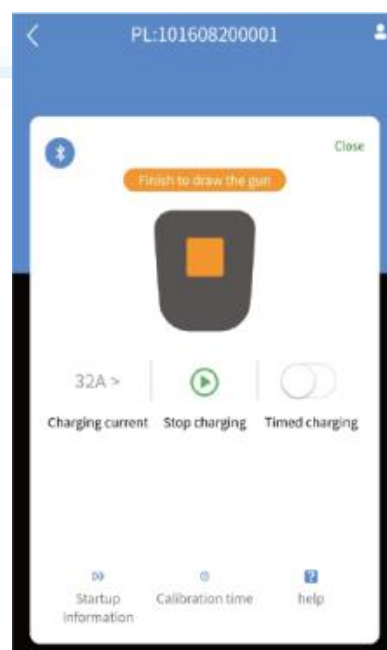
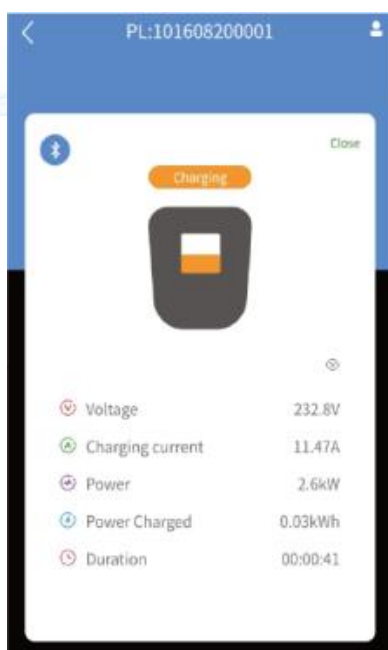

## 6. Maintenance Instructions

Please keep a charger in ventilated location and do not block the air vents in the AC Charger.

- Clean the AC Charger at least three times a year, and keep the exterior clean at all times.
- Clean the outside of the cabinet with a damp cloth or wet cotton towel, only use low-pressure tap water and cleaning agents with a PH level between 6 and 8.
- Do not apply high-pressure water jets.
- Do not use cleaning agents with abrasive components and do not use abrasive tools. Improper cleaning agents might spoil the coating, paint, surface, brightness and durability of all exterior parts.
- If there is water intruding into the AC Charger, then please cut off the power source immediately and contact the AC Charger provider for re- pair.
- Please make sure the charging connector is returned to its holder after charging to prevent damage.
- If there is damage to the charging connector, charging cable charging connector holder, then please contact the AC Charger provider.
- When using the AC Charger, please handle it properly. Do not strike or scrape the cabinet or touch screen.
- If the enclosure or screen is broken, cracked, open or shows any other indication of damage, then please contact the AC Charger provider.



### **WARNING:**

Danger of electrical shock or injury. Turn OFF power at the panelboard or load center before working on the equipment or removing any component. Do not remove circuit protective devices or any other component until the power is turned OFF.

Disconnect electrical power to the AC Charger before any maintenance work to ensure it is separated from the supply of AC mains. Failure to do so may cause physical injury or damage to the electrical system and charging unit.

the



### **Note:**

Before switching off the main breaker to begin maintenance, please record the status code number on the LCD monitor.

- After the maintenance door is opened or the charger NFB is turned off, the charger is still hazardous. Only do visual inspections.
- Maintenance of the AC Fast Charger shall be conducted only by a qualified technician.
- After opening the front door of the AC Fast Charger, turn off the main breaker and auxiliary breaker before beginning any maintenance work.
- Please confirm the main power junctions are tightened every month and rotate cables to test when the power is off. If any main power screw is loose, the charger will be damaged or contain smoke on the connections. Please confirm the screw torque requirement table.
- Charging cable maintenance: Do not twist or bend the charging cable. The metal contact should not fade or rust.



## 6.1. Error Codes

Fault Code	Fault Status	Troubleshooting suggestion
01	RTC fault	Please contact after-sales service.
02	Card reader fault	Check whether the connecting cable of the card reader is loose.
04	EPO fault	Reset emergency stop button.
05	Over voltage alarm	Check whether the input voltage of the equipment is too high.
06	Under voltage alarm	Check whether the input voltage of the equipment is too low.
07	FRAM fault	Please contact after-sales service.
08	Flash fault	Please contact after-sales service.
09	Phase line alarm	Check AC input/output wires if be normal, or if inverse connection input with L/N wires.
10	Lean alarm	Place the charging point vertically.
11	Electric meter fault	Check whether the meter connecting wire is loose.
12	Relay fault	Please contact after-sales service.
13	Over temperature alarm	Stop using for a period of time and wait for the equipment to return to the normal temperature range and restart.

## 7. Check List

### 7.1. Check before power on

#### Environmental Check

Item	Status	Remark
Ambient Temperature		
Ambient Humidity		
Sunshade		Recommended but not required.
Rain Canopy		Recommended for better charging experience and maintenance on rainy day.

#### External Infrastructure Readiness & Check

Item	Status	Remark
Input Wirings & Terminals		Type/Length/ Cross Section
Key & Lock of Cabinet Door		
Fixing Screws		Type/No.
Input Electricity Capacity		
Input Electricity Configuration		Wye
Grounding System		
Input Voltage & Frequency		
Network Connection & Quality		Wi-Fi, 4G > -65 dBm

**EV Charger Check – Static (Non-Powered)**

Item	Status	Remark
Outlook		
Labeling & Warning Signs		
Package (Accessory) List		
Robustness of Input Wirings & Connection		

**EV Charger Check - Power On**

Item	Status	Remark
Screen On		
Acoustic Noise		
Screen Display & Function		
Time Display Correctly		
Network Connection Quality		
Cooling Fans Operation & Noise		
Led Status Indication		
EV Charger Setting		
Function of Engineer Mode		
Version of H.W. & F.W.		
Remote Control & Monitoring		
Backend Server Connection		
Network Connection & Quality		Wi-Fi, 4G > -65 dBm

**EV Charger Check –System Power Button**

Item	Status	Remark
Emergency Stop Button & Recovery		

**7.2. Check after powered**

Please check / re-check the following items prior to initial Power-on:

- 5) The location of the charger should be convenient for operation and maintenance.
- 6) Before installation of the charger, ensure that the AC input component in the power supply is properly installed with the required protection.
- 7) Double confirm the charger is installed properly.
- 8) No components or other items have been left inside of the charger.



No. 15, Keji 6 Road, ChuangXin Haian,  
Tangjia Hi-tech Zone, Zhuhai, Guangdong, China.

[www.sinoevc.com](http://www.sinoevc.com)

sinoevc@pmac.com.cn

+86 756 6931888 ext 6056