



**WINROLLER**



# **DGDD gearless motor**

**Φ50 Φ67 Φ100**

JIANGSU WINROLLER TECHNOLOGY CO.,LTD

Dedicated to logistics sorting

# ABOUT US

## JIANGSU WINROLLER TECHNOLOGY CO.,LTD

WINROLLER is miniature and small motor roller expert founded in 2011. It is a pioneer enterprise that has been engaged in drum motor R&D and production earlier in China, providing customers with value-added services such as drum motor equipment optimization, intelligent drive process consultation and optimization.

WINROLLER has more than 300 employees, including 35 R&D personnel, more than 20 patents, and more than 20 scientific and technological achievements in total. It has established long-term cooperation with many scientific research institutions, and has completely independent design, R&D and mass production capabilities. Its products have obtained ISO9001 quality system certification, EU CE certification, etc.

The DC motor roller, AC motor roller, DD motor roller, DM motor roller and idler roller independently developed by WINROLLER have been widely used in domestic large-scale logistics, security inspection, industrial automation and other fields, and have established long-term and stable cooperative relations with large domestic application companies such as SF Express, Sto Express, Yunda Express, JD, BYD, Hikvision, CATL, and are exported to Australia, Germany, the United States, Peru Mexico and other countries.

### Products include:

Micro-motorized roller for rolling transmission;

Small motorized roller for the belt conveyor;

Suitable for higher requirements of DC24V, DC48V DC motor roller, AC servo motor roller and idler roller

### Roller diameter :

38、 50、 57、 60、 67、 76、 89、 100、 113、 138、 165、 216



# CATALOG

|           |  |     |
|-----------|--|-----|
| <b>01</b> | <b>Definitions</b>                               | P05 |
|           | Direct drive motor roller advantage              | P06 |
|           | Selection table                                  | P06 |
|           | Application specification                        | P08 |
| <b>02</b> | <b>DGDD motor roller parameters</b>              | P10 |
|           | I-Motor roller specification                     | P11 |
|           | Servo motor parameters                           |     |
|           | II-Drive parameter                               | P12 |
|           | A-S48Bservo motor driver overview                |     |
|           | III-Terminal definition and signal indication    | P13 |
|           | Terminal definition                              |     |
|           | Manual switch wiring diagram                     |     |
|           | IV-Commissioning and operation                   | P18 |
|           | Precautions before commissioning                 |     |
|           | Commissioning and operation                      |     |
|           | V- Troubleshooting                               | P19 |
| <b>03</b> | <b>Application:small sort wheel</b>              | P20 |
|           | I-Motorized roller specifications                | P21 |
|           | DC brushless motor parameters                    |     |
|           | Roller dimensions                                |     |
|           | Driver main parameters                           |     |
|           | Driver appearance size                           |     |
|           | II-Interface definition                          | P23 |
|           | -Test wiring example                             | P24 |
|           | Infrared module driver installation requirements |     |
|           | IV -IOcontrol                                    | P25 |

## 04 Application:narrow band motorized roller P27

### I-Motor roller specifications P28

67DC brushless motor parameters

Roller dimensions

50DC brushless motor parameters

Roller dimensions

### II -AD-S48 photoelectric servo driver P30

Driver overview

Terminal definition and signal indication

Schematic diagram of infrared transmitter board wiring

### Attach:motor roller selection table P43

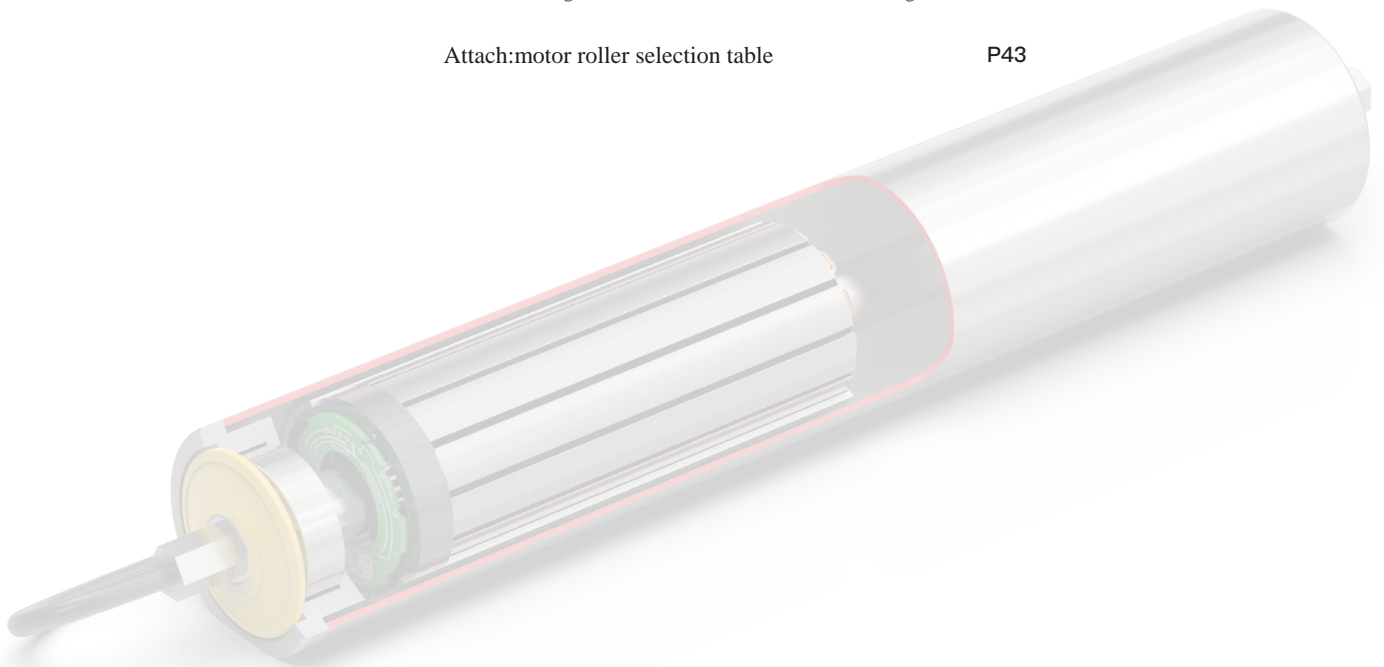

## Definitions

### Direct Driver Motor

Under the control of the drive system, the permanent magnet synchronous motor is controlled to rotate and achieve direct drive of the load. There are no reduction devices such as gearboxes, eliminating problems such as reverse clearance, noise, and lubrication caused by mechanical transmission. The speed range is extremely wide, with constant torque, and outstanding advantages such as low vibration, low noise, energy conservation, and long service life

### Servo/Magnetic Encoders

It can accurately control motor speed, position, torque, acceleration and deceleration, and other states. Servo mainly relies on pulses for positioning. When a servo motor receives one pulse, it rotates the corresponding angle of one pulse to achieve displacement. The number of pulses is set to correspond with the pulses received by the servo motor, forming a closed loop and achieving precise positioning.

Using magnetic positive or linear Rayleigh to detect changes in magnetic pole position and feedback linear pulse signals, the detection resolution is high. It is mainly used in situations with high accuracy. As it is an incremental signal, it is necessary to find the zero position when using it.

Characteristics contrast table

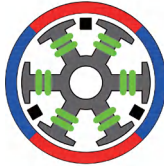
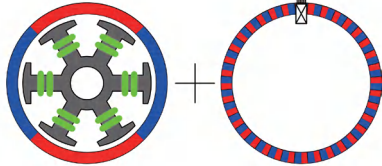
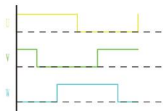
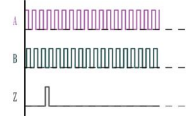
|  | HALL H  | Magnetic encoder M   |
|--|---|--|
| Signal resolution (2 pair poles motor) | 42  | 2048   |
| Motor precision                        | low   | middle   |
| The lowest speed                       | 150   | 50   |
| Number of electronic components        | little  | more   |
| Number of lead lines                   | 5   | 8  |
| Zero position recognition              | no  | yes  |
| reliability                            | middle  | middle   |
| response speed                         | low   | middle   |
| cost                                   | low   | middle   |
| mechanism                              |  <p>Motor + Hall</p> |  <p>Motor + Magnetic encoder</p> |
| wave form                              |  <p>square wave</p>  |  <p>square wave</p>             |

## 直驱滚筒优点



### Direct drive

Suitable for frequent starts and stops



### Maintenance free

No gears inside the roller, maintenance free during long-term operation



### Efficient

Efficient and energy-saving design products



### High strength

High load-bearing capacity, suitable for belts



### Dynamic response

Dynamic response at the millisecond level



### Low noise

Suitable for occasions with high noise requirements



### Wide speed range

A wide speed range



### Low temperature resistance

Good on-load starting performance at 30 °C below zero

## Motor roller selection table

selection table

| Model Diameter                                     |                   | DGDD50 sorting roller  |     |     |     | DGDD67 cycloid roller |     |     |     |
|--|-------------------|--|-----|-----|-----|-----------------------|-----|-----|-----|
| Input voltage type                                 |                   | DC48V  |     |     |     | DC48V                 |     |     |     |
| Rated rotary speed R/MIN                           |                   | 350~1000   |     |     |     | 350~1000              |     |     |     |
| Rated torque<br>N.m                                | S1 working system | 0.5  | 1   | 1.5 | 2   | 0.8                   | 1   | 1.5 | 2   |
|  | S2 working system | 1  | 2   | 3   | 4   | 1.6                   | 2   | 3   | 4   |
| Rated power<br>W                                   | S1 working system | 50   | 100 | 150 | 200 | 40                    | 50  | 75  | 100 |
|  | S2 workingsystem  | 100  | 200 | 300 | 400 | 80                    | 100 | 150 | 200 |
| S1 Continuous conveying weight of belt conveyor kg |                   | 4  | 8   | 12  | 15  | 8                     | 10  | 15  | 20  |
| S2 belt conveyor continuous conveying weight kg    |                   | 8  | 15  | 23  | 30  |                       |     |     |     |
| controller   |                   | Must be equipped with a dedicated controller to use and cannot be directly connected to the power supply |     |     |     |                       |     |     |     |
| Feedback selection                                 |                   | H: HALL M: MAGNETIC ENCODER  |     |     |     |                       |     |     |     |

## Example of Product Model Ordering Code Selectio

| Model | Diameter        | Feedback     | Power   | Voltage           |
|-------|-----------------|--------------|---|-------------------|
| DGDD  | 50<br>67<br>100 | H<br>M<br>HM | Constant torque<br>(Torque/speed/power varies with different diameters) | 48V DC<br>220V AC |

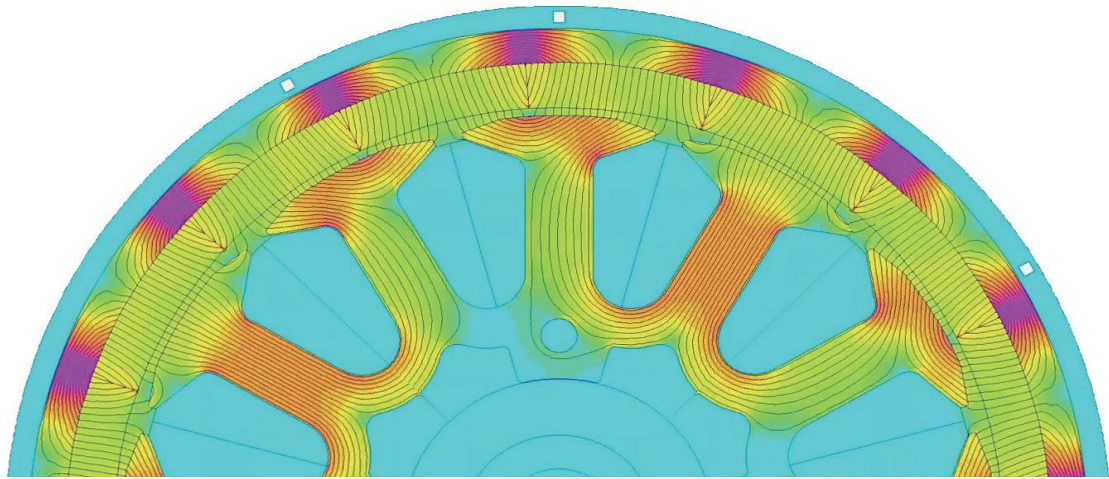

selection table

| DGDD67 sorting wheel |     |        | DGDD100M |     |        |      |
|----------------------|-----|--------|----------|-----|--------|------|
| DC48V                |     | AC220V | DC48V    |     | AC220V |      |
| 350~1000             |     |        | 350~550  |     |        |      |
| 1.5                  | 2   | 4      | 1.5      | 3   | 6      | 9    |
| 3                    | 4   | 8      | 3        | 6   | 12     | 18   |
| 150                  | 200 | 400    | 125      | 250 | 500    | 750  |
| 300                  | 400 | 800    | 250      | 500 | 1000   | 1500 |
| 12                   | 15  | 30     | 9        | 18  | 35     | 50   |
| 23                   | 30  | 60     | 18       | 35  | 70     | 100  |

Must be equipped with a dedicated controller to use and cannot be directly connected to the power supply

H: HALL M: MAGNETIC ENCODER

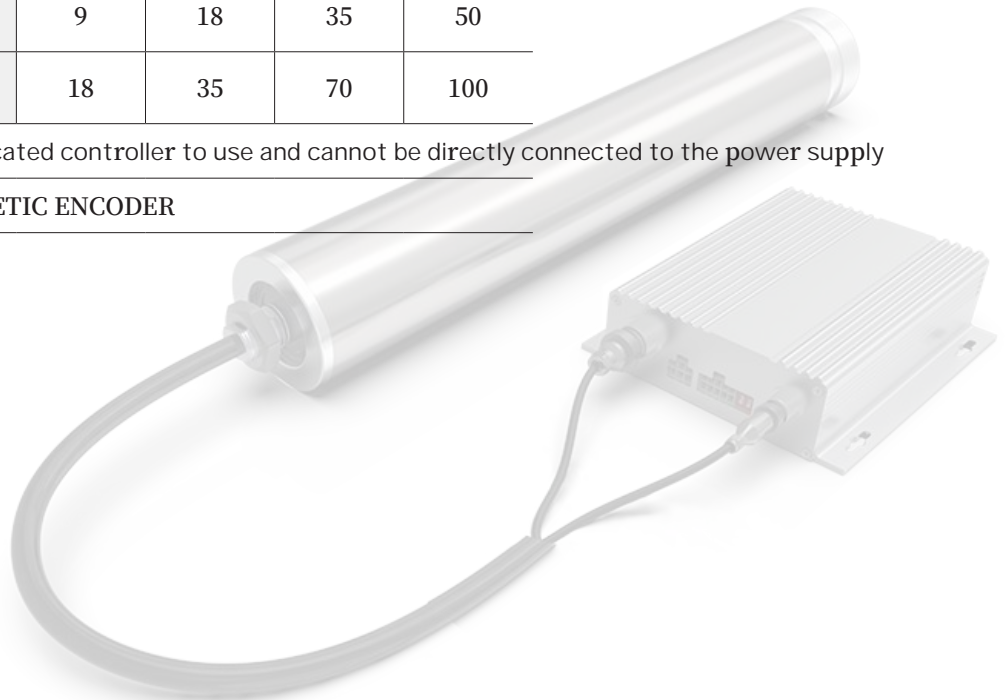

## DGDD67 DGDD70 cycloid roller for sorting use

input voltage : 48V  
 rated power : 50W/75W/100W  
 roller cylinder length : 73L/120L  
 Roller outer diameter : 067/070  
 Roller load : 15kg/20kg/25kg  
 Roller application : sorting conveyor  
 roller advantage: The installation roller array is composed of motor and roller, which can be centrally controlled by 485 communication bus for start stop speed regulation. There is no wear and consumption of traditional structures during operation, achieving maintenance free operation.

### Special drive for the cycloid roller:

communication mode: 485  
 Roller control: one controller can control four rollers  
 Installation method: control cabinet or mechanical structure bottom

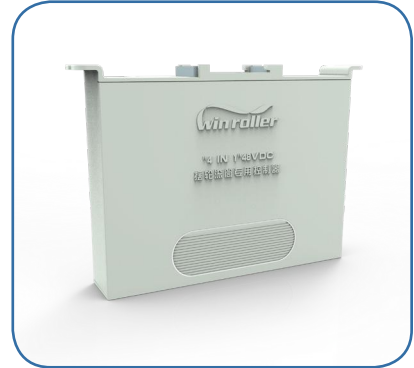
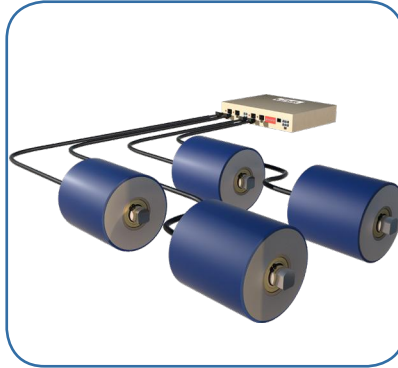
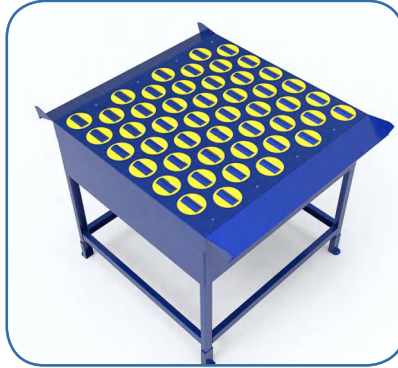

## DGDD50 Sorter machine

input voltage: 48V  
 rated power: 200W/300W/400W  
 roller cylinder length: 428L  
 roller outer diameter:  $\phi 50$   
 roller load: 15kg/23kg/30kg  
 Roller application: Cross-belt, weighing, sorting trolley



Logistics cross belt sorting machine

## DGDD67 Sorter machine

input voltage: 48V/72V/220V  
rated power: 200W/300W/400W/800W  
roller cylinder length: 428L  
roller outer diameter:  $\phi 67$   
roller load: 10kg/15kg/20kg/40kg  
Roller application: Cross-belt, weighing, sorting trolley



Cross-belt sorter package table

## DGDD67 Narrow-band sorter

input voltage: 48V/220V  
rated power: 200W/300W  
roller cylinder length: 176L  
roller outer diameter: 67  
roller load: 10kg/15kg  
Roller application: narrow band machine



Narrow-band sorter

## DGDD(67-100)-M 0-60-100-150-200Kg dynamic scale

Servo magnet magnetic external rotor permanent magnet motor:

input voltage: AC220V  
rated power: 400W/2500W  
roller rotary speed: 500-1000rpm  
communication mode: IO/485  
roller advantage: High precision control, real-time response, acceleration and deceleration can be adjusted to ensure smooth loading and unloading of packages. Suitable for packages of 60-100-150-200KG



Large dynamic weighing and scanning integrated machine

# DGDD直驱电动滚筒

— DGDD MOTOR DRIVE ROLLER —

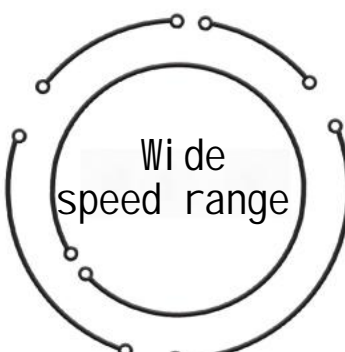
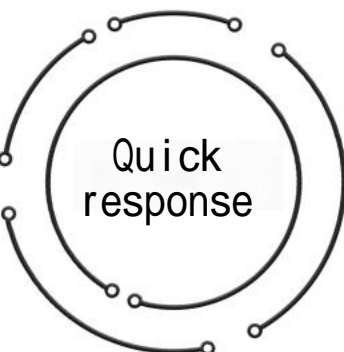
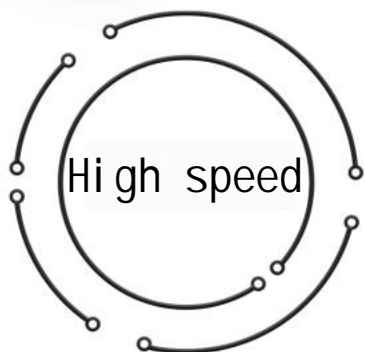

# I- Specification and parameters of the motor roller

## Parameters of the **DGDD** direct-drive servo motor roller

| Motor type                  |     | Direct drive servo motor |                  |
|-----------------------------|-----|--------------------------|------------------|
| Motor form                  |     | external rotor motor     |                  |
| Roller outer diameter       | mm  | 67                       |                  |
| rated voltage               | V   | DC48                     | +/-10%           |
| peak point current          | A   | 14                       |                  |
| rated power                 | W   | 300/400                  | S2 work system   |
| maximum load                | kg  | 15/20                    | S2 work system   |
| range of speeds of rotation | rpm | 300-1000                 |                  |
| Line speed range            | m/s | 1-3.5                    |                  |
| working form                |     | S2                       | Peak torque work |
| insulation grade            |     | F                        |                  |

### Product overview

This servo roller includes a roller shell, roller shaft, signal line, permanent magnet brushless DC motor, and an inductive encoder. The inductive encoder includes a rotation module and a stator module. The rotation module rotates with the roller shell and interacts with the stator module to receive a signal. After being processed by a chip, high-precision position signals are obtained and transmitted to the motor control system, accurately controlling the start and stop of the permanent magnet brushless DC motor. Speed control and power density monitoring, etc. The servo direct drive motor roller described in this product has many advantages such as compact structure, light weight, high position accuracy, and large torque. Moreover, due to the non-contact induction principle adopted by the inductive position encoder, it is suitable for working in various harsh environmental conditions, including damp, muddy, and dusty working environments.

### Overall size of the roller

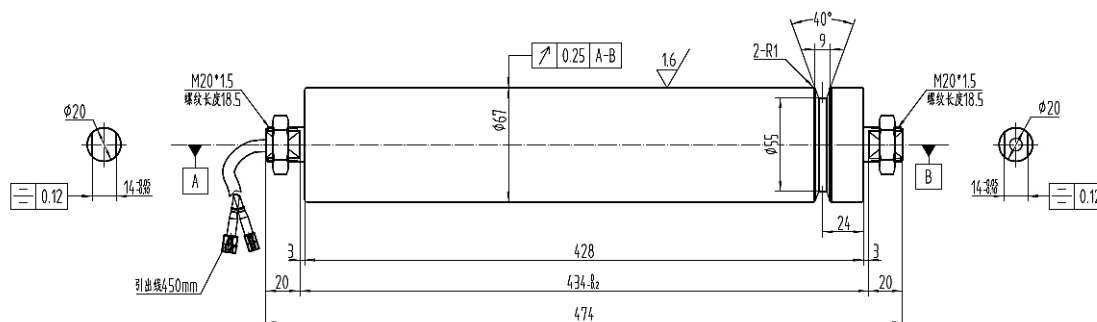

# II- Main parameters of the drive

## A-S48B servo roller drive overview

### ◎Basic specifications

| Item                            | Specification                       | Remark   |
|---------------------------------|-------------------------------------|--|
| Main power supply               | DC48V                               |  |
| Motor type                      | Permanent magnet servo motor        |  |
| Motor form                      | External rotor motor                |  |
| Rated power range               | 300W/400W                           |  |
| Range of speeds of rotation     | 30-1530RPM                          |  |
| Maximum current                 | 25A                                 |  |
| Working form                    | S2, Intermittent working system 25% | According to the ambient temperature situation |
| communication                   | RS485                               | 38400,N,8,1                                    |
| Working environment temperature | -25°C ~60°C                         |  |
| Humidity of working environment | 85% 以下                              | No condensation                                |
| Roller insulation grade         | F                                   |  |

### ◎Appearance and dimensions of the drive

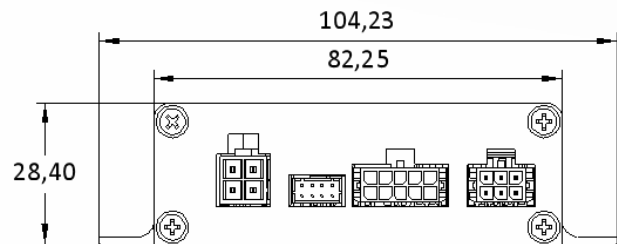
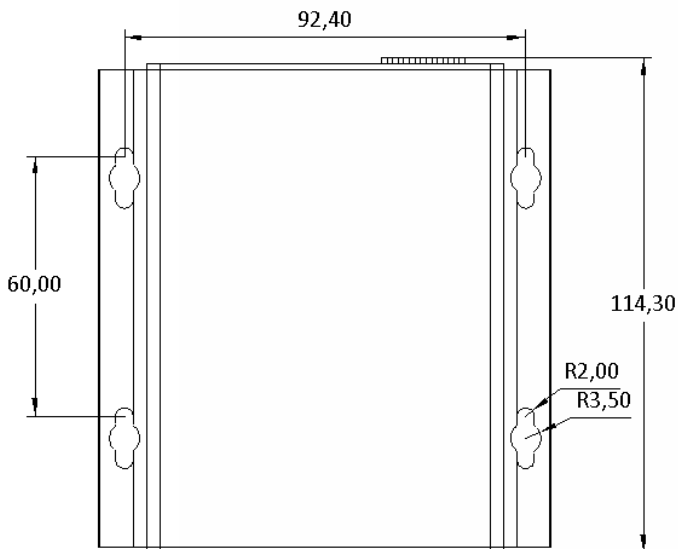

dimensional drawing 1

dimensional drawing 2

# III- Terminal definition and signal indication

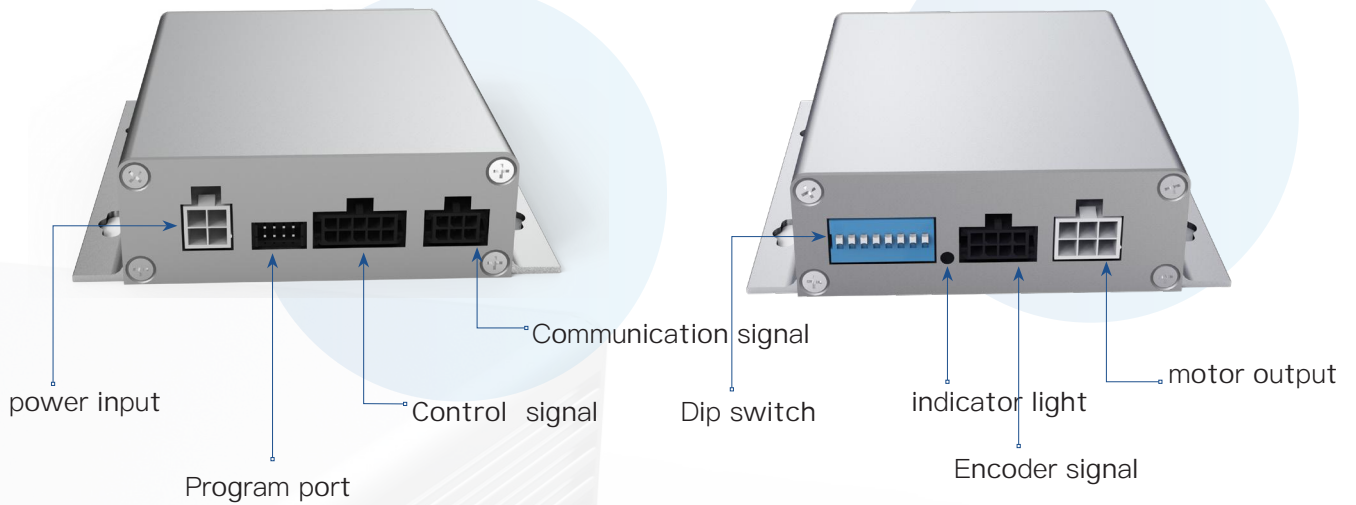

## Terminal defini

### Left terminal

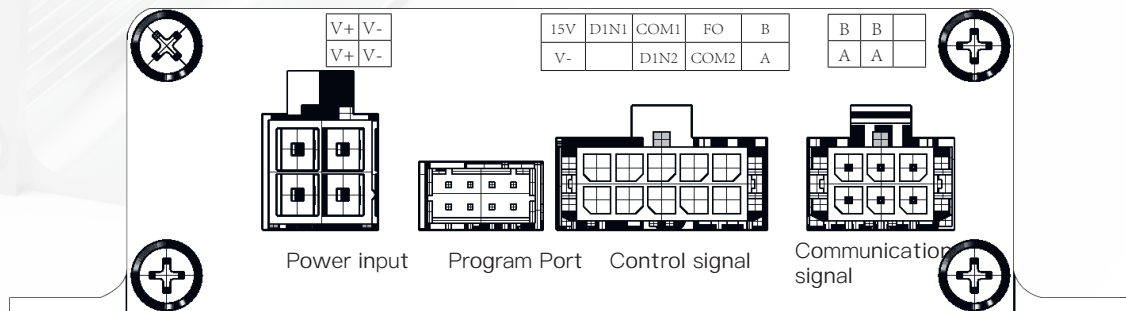

### power input

| port                    | model  | The pin order | Pin definition | remark                        |
|-------------------------|--|---------------|----------------|-------------------------------|
| Control signal port<br> | plug: HX42000-04R (5557-04R)<br>termina: HX42000-RT (5556)<br>red star | 2             | V+             | Power supply positive input   |
|                         |  | 4             | V+             |                               |
|                         |  | 1             | V-             | Negative input of powersupply |
|                         |  | 3             | V-             |                               |

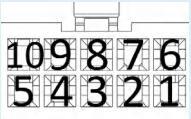

### Control signal

| port   | model  | The pin order | Pin definition | remark                         |
|--|--|---------------|----------------|--------------------------------|
| Control signal port<br> | plug: HX30002-10P<br>(43025-10P black)<br>terminal: HX30001-PT<br>red star | 10            | 15V            | I/O Port power supply          |
|  |  | 5             | V-             |                                |
|  |  | 9             | DIN1           | I/O Function 1                 |
|  |  | 3             | DIN2           | I/O Function 2                 |
|  |  | 8             | COM1           |                                |
|  |  | 7             | FO             | Failure output signa           |
|  |  | 2             | COM2           |                                |
|  |  | 1             | A              | Communication signal<br>RS485A |
|  |  | 6             | B              | Communication signal<br>RS485B |
| 4  |  | Empty pin     |                |                                |

### Control signal

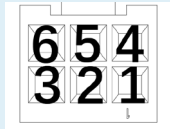
| port   | model   | The pin order | Pin definition | remark                         |
|--|---|---------------|----------------|--------------------------------|
| Control signal port<br> | plug: HX30002-10P<br>(43025-10P black )<br>terminal: HX30001<br>-PT<br>red star | 2             | RS485A         | Communication signal<br>RS485A |
|  |   | 3             | RS485A         | Communication signal<br>RS485A |
|  |   | 5             | RS485B         | Communication signal<br>RS485B |
|  |   | 6             | RS485B         | Communication signal<br>RS485B |
|  |   | 1             |                | Empty pin                      |
|  |   | 4             |                |                                |

### Communication signal port

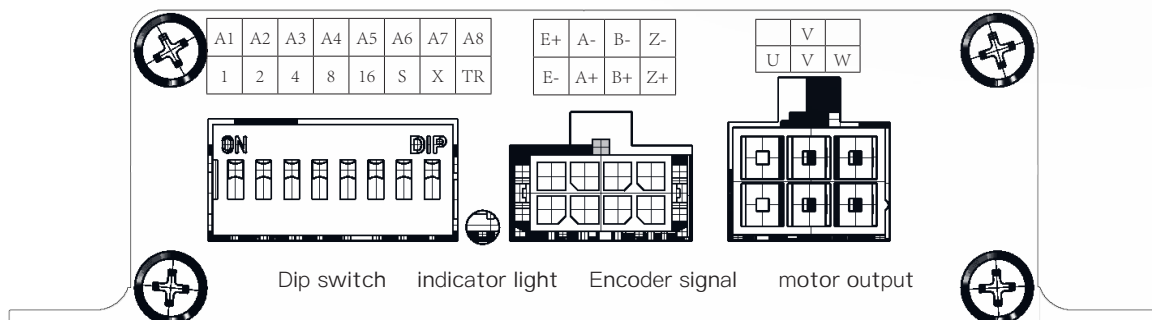

### ◎Dial switch interface-The RS485 operating mode

| Port       | Model            | Pin order | Pin definition       | Remark   |
|------------|------------------|-----------|----------------------|--|
| Dip switch | 8-bit Dip switch | A1        | 1                    | Drive address code:<br>Add=X1*1+X2*2+ X3*4+X4*8+ X5*16<br>X1~5 for switch status |
|            |                  | A2        | 2                    |  |
|            |                  | A3        | 4                    |  |
|            |                  | A4        | 8                    |  |
|            |                  | A5        | 16                   |  |
|            |                  | A6        | Reserve              |  |
|            |                  | A7        | Reserve              |  |
|            |                  | A8        | Termination resistor | ON: Termination resistor effective<br>OFF: The terminal resistance is invalid    |

### ◎Dial switch interface-10 operating mode

| Port       | Model            | Pin order | Pin definition       | Remark   |
|------------|------------------|-----------|----------------------|--|
| Dip switch | 8-bit Dip switch | A1        | X1                   | X4~X1: unit RPM<br>0000:600; 0001:100; 0010: 150<br>0011:200; 0100:250; 0101: 300<br>0110:350; 0111:400; 1000: 450<br>1001:500; 1010:550; 1011: 600<br>1100:650; 1101:700; 1110: 750 |
|            |                  | A2        | X2                   |  |
|            |                  | A3        | X3                   |  |
|            |                  | A4        | X4                   |  |
|            |                  | A5        | X5                   | Reserve  |
|            |                  | A6        | Reserve              |  |
|            |                  | A7        | Reserve              |  |
|            |                  | A8        | Termination resistor | ON: Termination resistor effective<br>OFF: The terminal resistance is invalid  |

### ◎Encoder signal

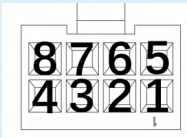
| Port  | Model   | Pin order | Pin definition | Remark                      |
|---|---|-----------|----------------|-----------------------------|
| Encoder signal<br> | plug: HX30002-8P<br>(43025-8P black)<br>) terminal:<br>HX30001-PT<br>red star | 1         | Z+             | Encoder differential signal |
|   |   | 2         | B+             |                             |
|   |   | 3         | A+             |                             |
|   |   | 5         | Z-             |                             |
|   |   | 6         | B-             |                             |
|   |   | 7         | A-             |                             |
|   |   | 4         | E-             | Encoder signal power supply |
|   |   | 8         | E+             |                             |

### ◎Motor output

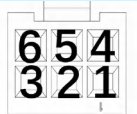
| Port  | Model   | Pin order | Pin definition | Remark               |
|---|---|-----------|----------------|----------------------|
| Encoder signal<br> | plug: 42000-06R<br>(5557-06R)<br>terminal: HX42000<br>-RT<br>(5556)<br>red star | 3         | U              | Motor UVW phase line |
|   |   | 2         | V              |                      |
|   |   | 5         | W              |                      |



◎Signal instructions

Light status table in fault state

| No | Flash of indicator light   | Information description  | Solution  |
|----|----------------------------|--------------------------|---|
| 1  | Flashing once per cycle    | Encoder failure          | Check the encoder wire and power it on again                  |
| 2  | Flashing twice per cycle   | Over temperature failure | Over temperature  |
| 3  | Flashing 3 times per cycle | Overflow failure         | Locked rotor or heavy load                                    |
| 4  | Flashing 4 times per cycle | Locked rotor fault       | Locked rotor or heavy load                                    |
| 5  | Flashing 5 times per cycle | Overload fault           | Locked rotor or heavy load                                    |
| 6  | Flashing 6 times per cycle | Low voltage fault        | With the voltage below 25V, restore the voltage to above 30V  |
| 7  | Flashing 7 times per cycle | High voltage fault       | Voltage above 70V, reduce the voltage to below 65V to recover |

Light status table in normal condition

| No | Flash of indicator light | Information description                  | Solution  |
|----|--------------------------|--|---|
| 1  | Version number flashing  | Software version number                  | Power on and start flashing                                       |
| 2  | Cycle flashing           | The motor flashes according to the speed | Flashing indicates receiving the correct command and executing it |
| 3  | keep lighting            | standby state                            |   |

Schematic diagram of manual switch wiring

To ensure better product performance, our company's IO mode is compatible with both internal and external power supply modes during operation; It is also compatible with NPN type and PNP type wiring. If long-term control operation such as PLC is required externally, external power supply wiring method can be selected; If it is only for internal factory testing, you can choose the internal power supply wiring method, as detailed below.

◎External power supply NPN wiring:

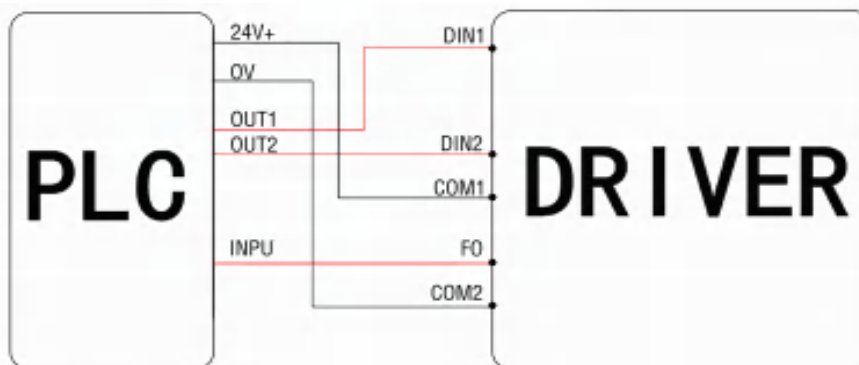

((Above figure) NPN wiring diagram for external power supply of the drive

©Internal power supply NPN wiring or manual switch wiring:

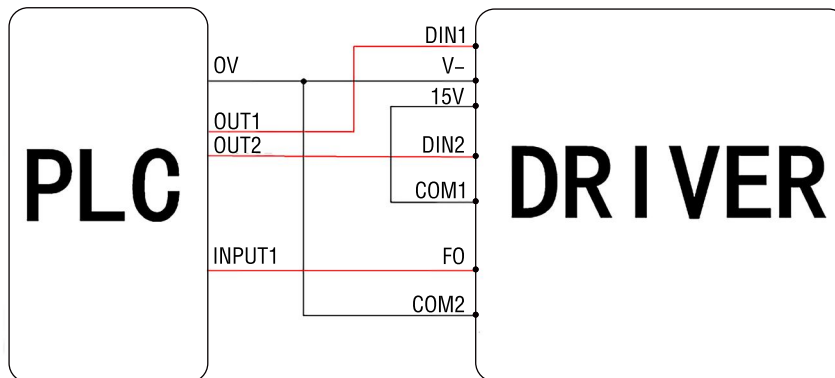

(Above figure) Internal power supply NPN wiring diagram or manual switch wiring diagram of the drive  
Replacing the two NPN transistors in the PLC with two switches can become a switch control method.

© PNP connection method:

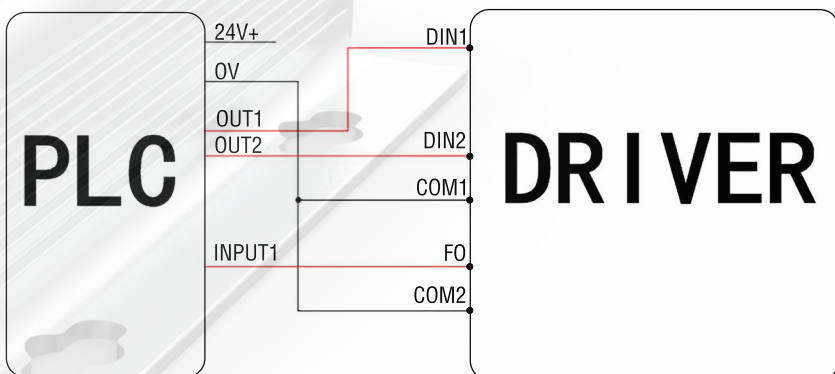

(Above figure) Drive PNP wiring diagram

Due to the fact that PNP models must have external power supply, there is no internal power supply connection.

©Communication control connection method:

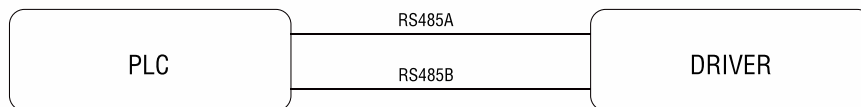

(Above figure) Drive communication line wiring diagram

Attention:

1. Wiring. Please use star connection method;
2. Please use twisted pair or shielded twisted pair;
3. On site, please dial the terminal resistance dial code at the end of the RS485 bus or the terminal resistance dial code at both ends according to the situation. Each RS485 bus can only dial up to two terminal resistors.
4. Generally, each group of RS485 buses only needs to dial one terminal resistor. If you need to dial two terminal resistors, please contact the manufacturer for consultation. .



# IV- Debugging and operation

## Precautions before debugging

- ★Regarding electrostatic discharge, the cross band refers to a large device that operates together with stationary and moving components. Due to the operation of the loop line, the operation of the trolley belt will generate static electricity. Please ensure good grounding of the moving and stationary racks to prevent static interference from affecting the operation of the trolley. It is recommended to connect the metal parts of the car to the frame grounding through a sliding contact wire.
- ★Regarding the RS485 terminal resistor, when the line is too long, it is necessary to connect the terminal resistor. However, connecting the terminal resistor will reduce the signal amplitude. It is recommended to only connect the terminal resistor at the end that is physically farthest from the PLC
- ★ Regarding the power supply, to prevent the power supply from rising when the car slows down and stops, please carefully configure the power capacity. Note that the higher the speed/acceleration, the heavier the load, and the more significant the power lift. Please ensure that the capacity of the loop power supply is sufficient.
- ★There are two ways to wire RS485 cables, one is master-slave wiring, and the other is to use the two terminals of the driver for manual wiring. The former advantage is that if a driver is broken, the cable can be unplugged and used again, but the signal reflection is large and needs to be connected to a junction box; The advantage of the latter is good signal quality and simple wiring, but the disadvantage is that if one wire breaks, it will affect the entire communication group. The manufacturer is requested to design a solution according to the project situation.
- ★Regarding the bending of the cross belt: Due to the cable pulling or curling during bending, please ensure that the wiring harness is fixed to prevent loosening or wear.
- ★Due to the limited overcurrent capacity of the drive, please do not use the power plug on the drive for a one in one out design to prevent burning the drive.

## Debugging and operation

Set the car address to 1 # and send the following command to make the car move. The following is in hexadecimal:

©Send without reply code:

PLC sending: 0X95 0X01 0X46 0X00 0X4C 0X02 0X00 0X09

Continue sending: 0X8A 0X01 0X00 0X00 0X00 0X00 0X00 0X01

©Send with reply code::

PLC sending 0X95 0X01 0X46 0X00 0X4C 0X02 0X00 0X09

: Drive code back 0X95 0X01 0X46 0X00

after 2ms: Drive code back 0X8A 0X01 0X00 0X00 0X00 0X00 0X00 0X01

after 2ms : :

The above parameters represent:

Car number: 1#;

rotate speed420RPM;

Delayed running time: 为 0;

operational mode: temporal mode;

operation time: 128+0x4C=204, is

2040ms; operationPI: 1/16PI;

accelerated speed: 1.5+0\*0.05=1.5m

/s2

# V- Troubleshooting

## ◎Towing test, power protection

★The manufacturer may trigger power under voltage, over voltage, or over current protection during the towing test. In the drag test, especially under load conditions, the acceleration section consumes energy, while the deceleration and stop sections generate energy feedback, causing the power supply voltage to rise, which can lead to switching power supply protection. We suggest using a switching power supply with sufficient capacity for testing (around 1.5KW), which can be connected in parallel with a capacitor (10000uf/100V) on the power side, or connected in series with a diode (at least 200V50A or above) on the power side. Due to the large number of loop cars during official use, there is generally no impact.

## ◎Communication command not running

★ Ensure that there is no virtual connection in the wiring harness, and the terminal resistor is set to the farthest one from the PLC;

★ Ensure that there are no duplicate address codes;

★ Note that when issuing the 0X85 command, due to the driver's need to return the code, when issuing the next 0X8A command, it is necessary to wait at least 5ms in advance to prevent bus conflicts;

★ Check whether there is a connection between 485A/B and 48V+, 48V -, and PE in the on-site wiring, which can be gradually investigated using a binary method;

If the car operates normally when the loop line is stationary and not normally when the loop line is moving, it is also necessary to check for poor contact of the brushes, check for normal operation of the switch (which may cause delay), and check if the carrier frequency of the linear motor has decreased to 4KHZ.

## ◎Upper and lower package parameters

★Based on multiple on-site debugging, the following are empirical values that can be used as a reference. Please make adjustments according to the on-site situation.

Unpacking: Using speed mode, running time of 1 second, running speed of 600, PI value of 10/16, acceleration of 4-5 M/S<sup>2</sup>.

Packaging: Using position mode, customized running distance, running speed of 420, PI value of 10/16, acceleration of 3-3.5 M/S<sup>2</sup>.

## ◎Debugging suggestions

★When the on-site debugging time is short but actual sorting is required, the maximum acceleration of 7.85M/s<sup>2</sup> can be used for unloading the package. At this time, the accuracy requirement for loading the package is minimal, but it will only cause the vertical package to roll. When the debugging is mature, reduce it to 4-5 M/S<sup>2</sup> to reduce rolling;

★Due to the load of the bus, it is recommended that each RS485 bus does not drive more than 24 drives;

★In practical applications, the PI value can be solidified to 14/16 without modification. If it is not suitable, it is recommended to take a value between 10 and 16. The larger the on-site load, the greater the PI tends to be. It is recommended to use only RS485A and RS485B wires for communication control, and other wires do not need to be connected to prevent the introduction of possible interference signals.

## ◎False alarm fault

★ Check if the electric brush is well connected and the trolley needs to be well grounded;

★ Check if the motor wire and encoder wire are damaged;

★ Check if the fixing nut is tight.

# 应用篇

## 分拣小摆轮

### — DGDD SORTING PINWHEEL —

随着物流行业的飞速发展，摆轮分拣设备和分流设备也被大量应用，传统的机械结构的摆轮设备在客户使用过程中容易产生传动部件的磨损和故障，“小摆轮”是特别为此类设备量身定制一款产品，每个动力单元都是独立的一款电动滚筒，运转过程中没有传动部件的磨损和消耗，实现免维护运行。

#### 标准品参数

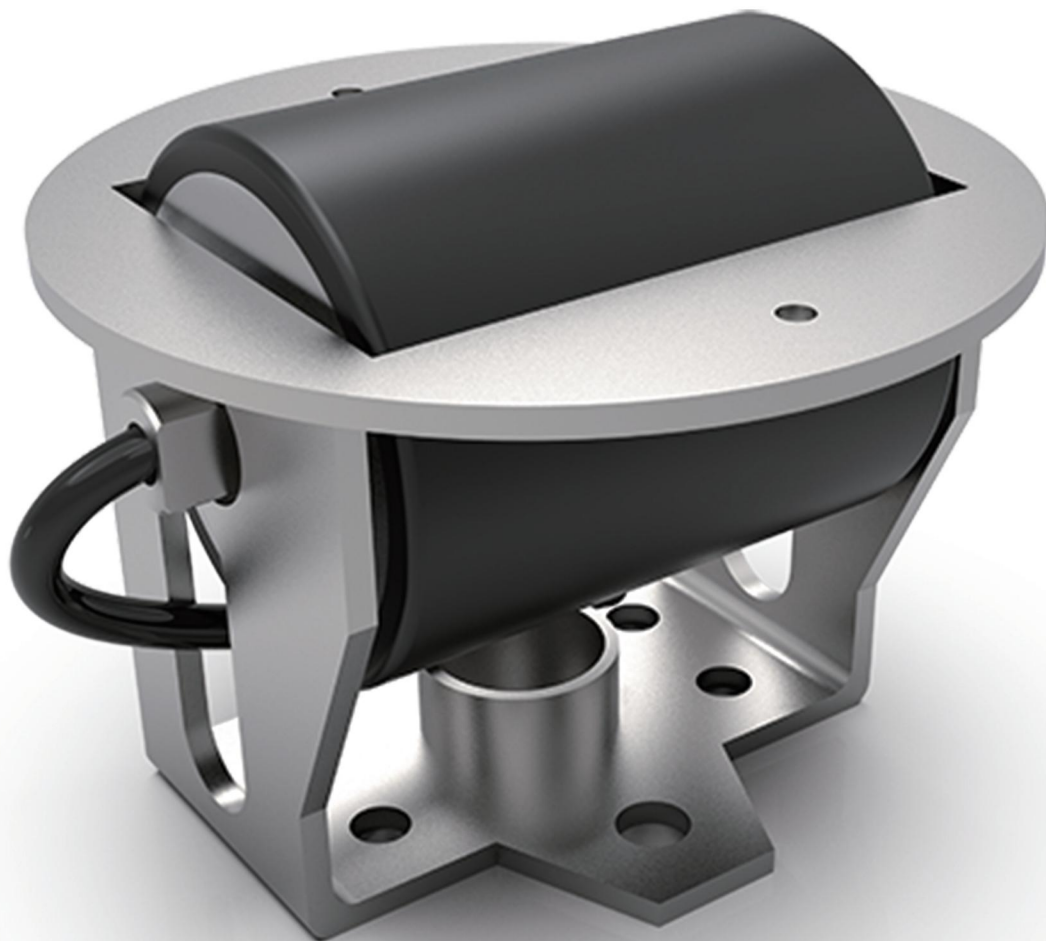

# I- Specification parameters of motor roller

## DC brushless motor parameter

| 版本 Rev.               | Unit | Specification      | Description             |
|-----------------------|------|--------------------|-------------------------|
| Motor type            |      | DC brushless motor |                         |
| Motor form            |      | outer rotor motor  |                         |
| Roller outer diameter | mm   | 70                 | Coating thickness 3.5mm |
| Rated voltage         | V    | DC48               | +/-10%                  |
| Maximum current       | A    | 10                 |                         |
| Rated power           | W    | 50                 | S1 working system       |
| Rated torque          | N.m  | 1                  |                         |
| Rotary speed range    | rpm  | 350-1000           |                         |
| Line speed range      | m/s  | 1-3.5              |                         |
| Insulation grade      |      | F                  |                         |

## Overall dimensions of the roller

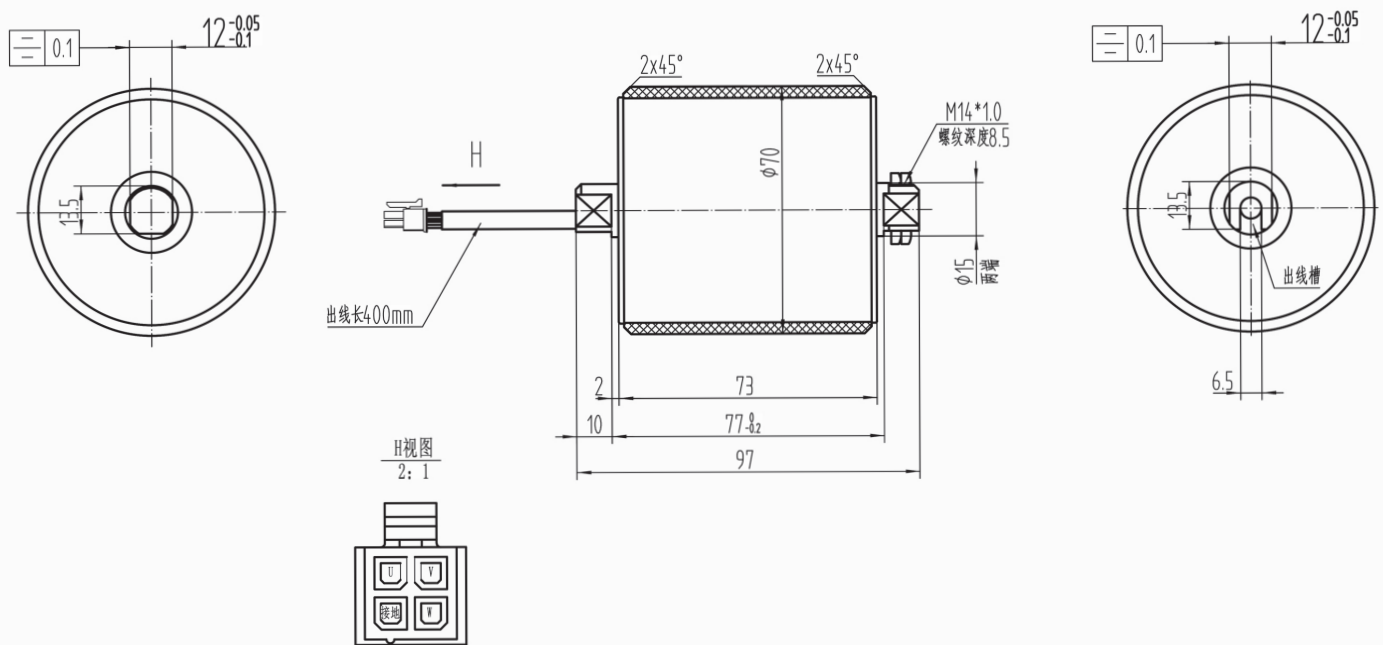

## Main parameters of the drive

| 版本 Rev.                           | Unit | Specification      | Description   |
|-----------------------------------|------|--------------------|---|
| drive type                        |      | DC brushless drive | sensorless  |
| input rated voltage               | V    | DC48V+/- 10%       | DC stabilized voltage source  |
| output power                      | W    | 100*4              | Each motor interface100W  |
| drive size                        | mm   | 175*120*35.2       |   |
| drive communication method        |      | RS485              | 38400 bps,N,8,1 Free Agreement  |
| Working environment temperature°C |      | -25~60             |   |
| Operating environment humidity    |      | 85% 以下             | No condensation   |
| Protection Grade                  |      | IP20               | No special protection against water or moisture;<br>Prevent diameter greater than 12.5mm solid foreign object intrusion |

## Drive appearance size

Drive appearance size 1

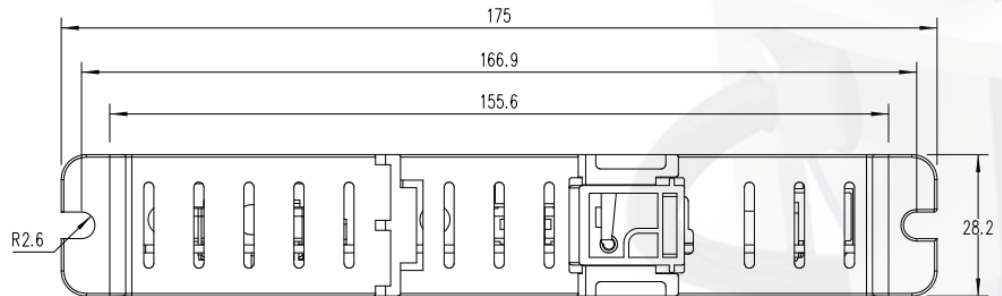

Drive appearance size 2

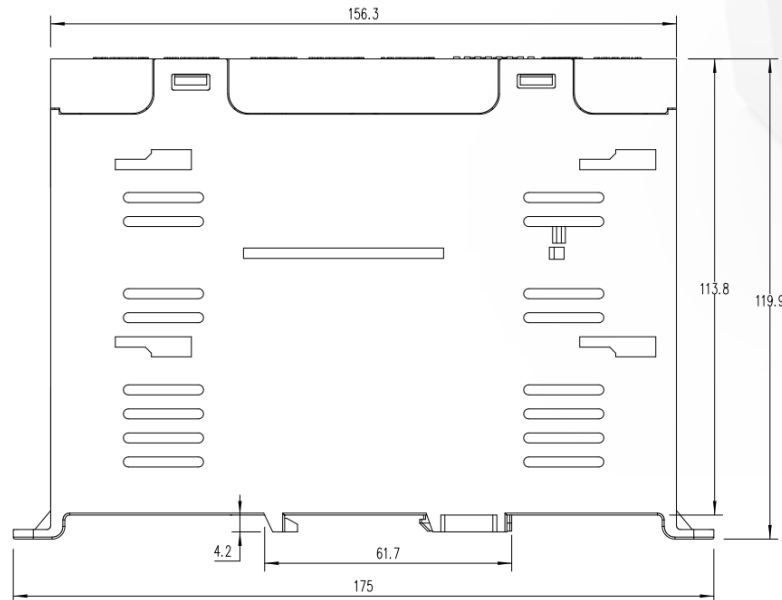

# II - interface definition

## © Drive Layout

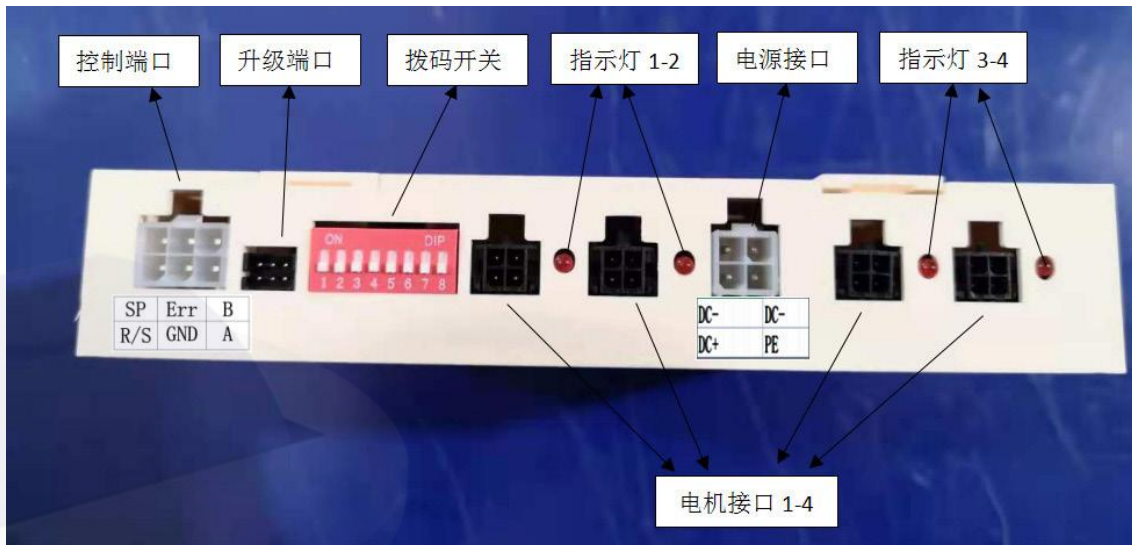

## © Interface and Switch Description

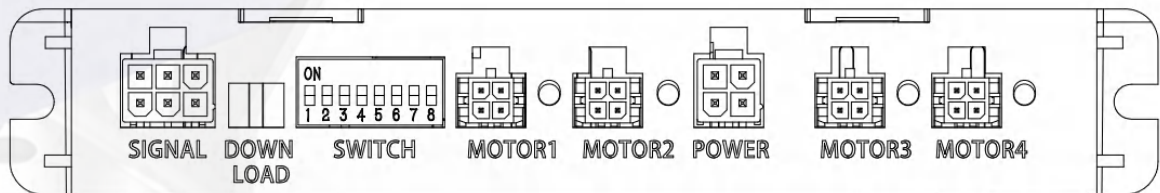

## © Interface Description

| Item name         | Adapting plugin | Port Definition | Remark   |
|-------------------|-----------------|-----------------|--|
| power interfac    | HX42000-4R      | DC+             | DC48V Power +  |
|                   |                 | DC-             | DC48V Power -  |
| control interface | HX42000-6R      | SP              | High and low speed switching (invalid low speed, effective high speed) |
|                   |                 | R/S             | Enable operation (invalid stop, effective operation)                   |
|                   |                 | Err             | Triode open collector output (fault output 0V, normal suspension)      |
|                   |                 | GND             | Signal reference ground (providing 0V effective level for R/S and SP)  |
|                   |                 | B               | 485 interface B  |
|                   |                 | A               | 485 interface A  |

## ◎ Interface Description

| control mode | Dialing number | Dialing Code Definition | Remark  |
|--------------|----------------|-------------------------|---|
| I/O          | 1~3            | Lb0~Lb3                 | Set the speed for low speed operation of the roller (SP port invalid)   |
|              | 4~6            | Hb0~Hb3                 | Set the speed for high speed operation of the roller (SP port is valid) |
|              | 7              | keep                    | keep  |
|              | 8              | unning direction        | Motor rotation direction  |
| 485          | 1~6            | addr0~addr5             | Set the 485 communication address within the range of 1~63.             |
|              | 7~8            | keep                    | keep  |

# III - Example of Test Wiring

## Installation requirements for infrared module drive

The connection between the drive and the power supply and the electric roller, as well as a simple wiring example of the control part, are shown in the following figure. I/O control is recommended for testing. Short circuiting of R/S and GND for low-speed operation; Short circuit SP and GND during operation and switch to high-speed operation.

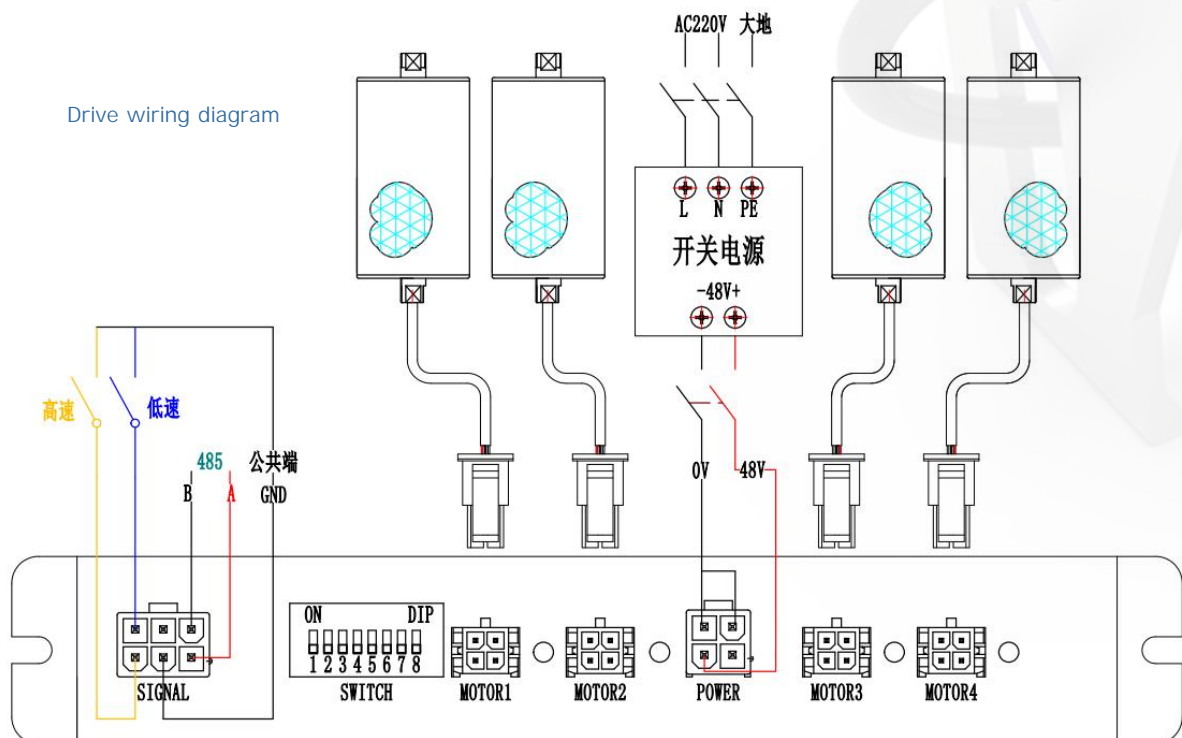

# IV -IO control

## © Working status under different input signals

| SP      | R/S     | illustration   |
|---------|---------|--|
| invalid | invalid | stop   |
| invalid | valid   | Low speed operation, refer to the low speed operation dial table for running speed, and use the 8th dial control for running direction   |
| valid   | invalid |  |
| valid   | valid   | High speed operation, refer to the high-speed operation dial table for running speed, and use the 8th dial control for running direction |

## © Different dialing states correspond to different speeds, and the dialing state corresponds to different speeds

low speed operation dial table

| Dial code               | definition | L0 gear | L1 gear | L2 gear | L3 gear | L4 gear | L5 gear | L6 gear | L7 gear |
|-------------------------|------------|---------|---------|---------|---------|---------|---------|---------|---------|
| 1#                      | Lb0        | OFF     | ON      | OFF     | ON      | OFF     | ON      | OFF     | ON      |
| 2#                      | Lb1        | OFF     | OFF     | ON      | ON      | OFF     | OFF     | ON      | ON      |
| 3#                      | Lb2        | OFF     | OFF     | OFF     | OFF     | ON      | ON      | ON      | ON      |
| Corresponding speed rpm |            | 350     | 400     | 450     | 500     | 550     | 600     | 650     | 700     |

High speed operation dial table

| Dial code               | definitio | L0 gear | L1 gear | L2 gear | L3 gear | L4 gear | L5 gear | L6 gear | L7 gear |
|-------------------------|-----------|---------|---------|---------|---------|---------|---------|---------|---------|
| 4#                      | Hb0       | OFF     | ON      | OFF     | ON      | OFF     | ON      | OFF     | ON      |
| 5#                      | Hb1       | OFF     | OFF     | ON      | ON      | OFF     | OFF     | ON      | ON      |
| 6#                      | Hb2       | OFF     | OFF     | OFF     | OFF     | ON      | ON      | ON      | ON      |
| Corresponding speed rpm |           | 650     | 700     | 750     | 800     | 850     | 900     | 950     | 1000    |

## © End input port (R / S & SP) wiring instructions

### ◆ R / S & SP port valid signal

1. Automatic identify high level (DC48V) and low level (0V).
2. If using a DC48V signal, it is recommended to connect the signal from the positive pole (+) of the drive power supply, as shown in the reference wiring diagram on this page
3. If a 0V signal is used, the signal must be connected from the drive control interface GND, as shown in the reference wiring diagram on this page.
4. If using a DC24V signal (PLC, etc.), please share the negative pole between the DC24V control system and the drive power supply system
5. The priority of the I/O signal is lower than that of the 485 communication command.

◆ Internal circuit diagram of R/S&SP ports

Internal effective circuit diagram of the driver when connecting high level (left) and low level (right)

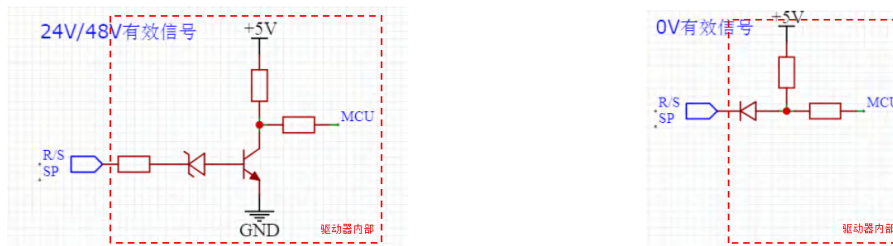

◆ Internal circuit diagram of R/S&SP ports

Connecting DC48V – (0V) wiring diagram (left), connecting DC48V+ wiring diagram (right)

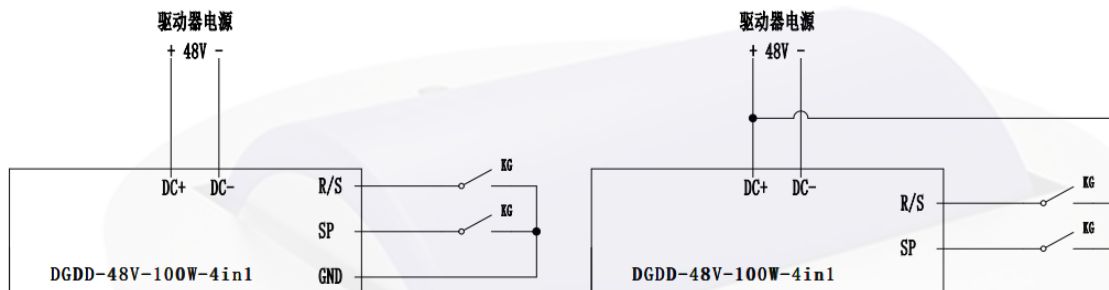

### ◎Output port (Err) wiring instructions

Open collector output, only low level output, Err Port Internal Circuit Diagram,

Err Port Internal Circuit Diagram

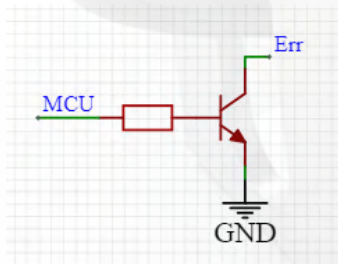

take Wiring Diagram for reference

Fault Output Low Level Wiring Diagram

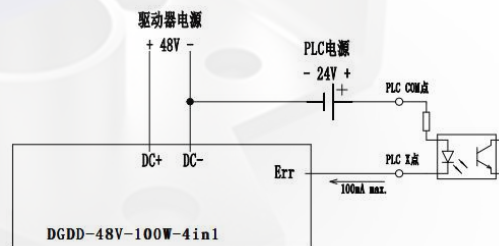

# 应用篇

## 窄带电动滚筒

### — NARROW BAND ELECTRIC ROLLER —

◎ 常规的滚筒驱动连接方式都是通过漏波电缆实现通讯的，随着市场对自动化的要求越来越高，也在不断的探索如何更加高效的驱动方式和滚筒配合。传统连接驱动漏波电缆虽然有着调试简单等优势，但是缺点也逐渐暴露，例如：覆盖距离中等；在大型应用上成本较高，随之而来的带来的就是安装比较复杂。在节距较短的应用场景下还极易收到干扰，带来产品失效。

◎ 针对现有技术的不足，本实用新型提供一种电动滚筒红外驱动控制方式，以解决现有滚筒控制成本高，容易收到干扰等技术问题。本实用新型采用的技术方案如下：一种红外模块驱动，包括红外发射板（主控芯片，红外发射头）和红外接收板（包含壳体，中控芯片，红外接收器）两个模块。

◎ 其进一步技术方案为：

所述红外发射板固定在线体出货口或进货口。所述红外接收板固定在线体单个小车下方通过驱动与滚筒连接本实用新型的有益效果如下：本实用新型在实际运用场合中，通过红外感应的方式，直接通过485或者IO的方式提供给驱动器信号，再由驱动器直接控制电机，极大的降低了使用成本。

**传统驱动方式：**

接收板 → PLC → 漏波电缆 → 485 → 驱动 → 滚筒

**红外感应驱动：**

接收板 → 485 → 驱动 → 滚筒





## Φ 50 DC brushless motor roller Parameter

| 版本 Rev.               | Unit | Specification                 | Description           |
|-----------------------|------|-------------------------------|-----------------------|
| Motor type            |      | DC brushless Hall/servo motor |                       |
| Motor form            |      | outer rotor motor             |                       |
| Roller outer diameter | mm   | 50                            |                       |
| Rated voltage         | V    | DC48                          | +/-10%                |
| Rated power           | W    | 100                           | S2 working system     |
| Maximum load weight   | kg   | 8                             | S2 working system     |
| Rotary speed range    | rpm  | 300-1000                      |                       |
| Line speed range      | m/s  | 1-3.5                         |                       |
| working system        |      | S2                            | Peak torque operation |
| Insulation grade      |      | F                             |                       |

## Overall size of the motor roller

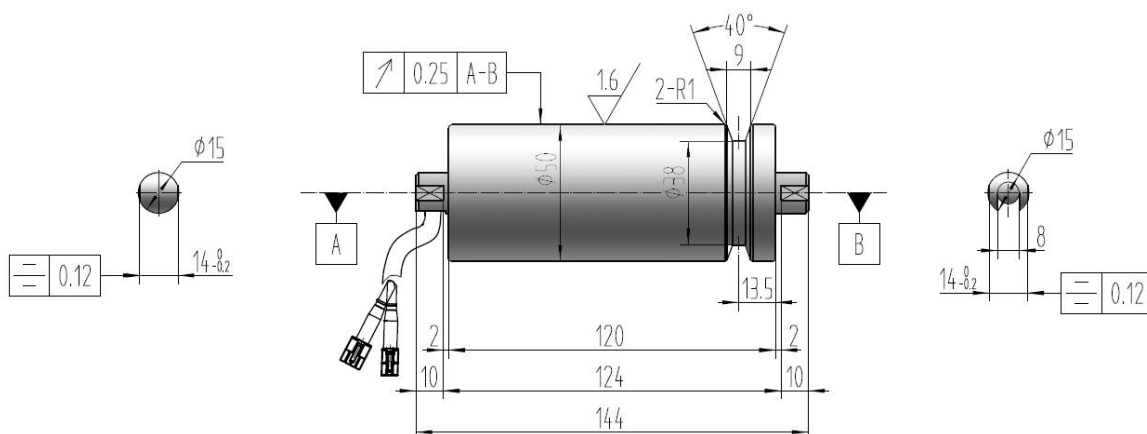

## II -AD-S48 Optoelectronic servo roller drive

### Overview of the drive

This product consists of two parts: a transmitter board and a drive board. The transmitter board is used to receive external signals (485 communication, IO) and then forward them to the drive board through IrDA. The board operates according to signal instructions.



Figure 1 System schematic diagram

### Basic specification of infrared emission plate:

| Item                            | Specification | Remark          |
|---------------------------------|---------------|-----------------|
| main power source               |               |                 |
| external communication mode     | RS485         | 38400,N,8,1     |
| Working environment temperature | 25°C ~60°C    |                 |
| Working environment moisture    | 85% under     | No condensation |

### Infrared receiving plate (drive) Basic specification:

| Item                            | Specification                         | Remark                                |
|---------------------------------|---------------------------------------|---------------------------------------|
| main power source               | DC48V -10%~+10%                       |                                       |
| motor type                      | Permanent magnet servo motor          |                                       |
| motor form                      | External rotor motor                  |                                       |
| rated power range               | 300W/400W                             |                                       |
| rotary speed range              | 30-1530RPM                            |                                       |
| maximum current                 | 25A                                   |                                       |
| working system                  | S2, intermittent work schedule of 25% | Depend on the environment temperature |
| Working environment temperature | -25°C ~ 60°C                          |                                       |
| Working environment moisture    | No condensation below 85%             |                                       |
| Roller insulation grade         | F                                     |                                       |

Infrared emitter size:

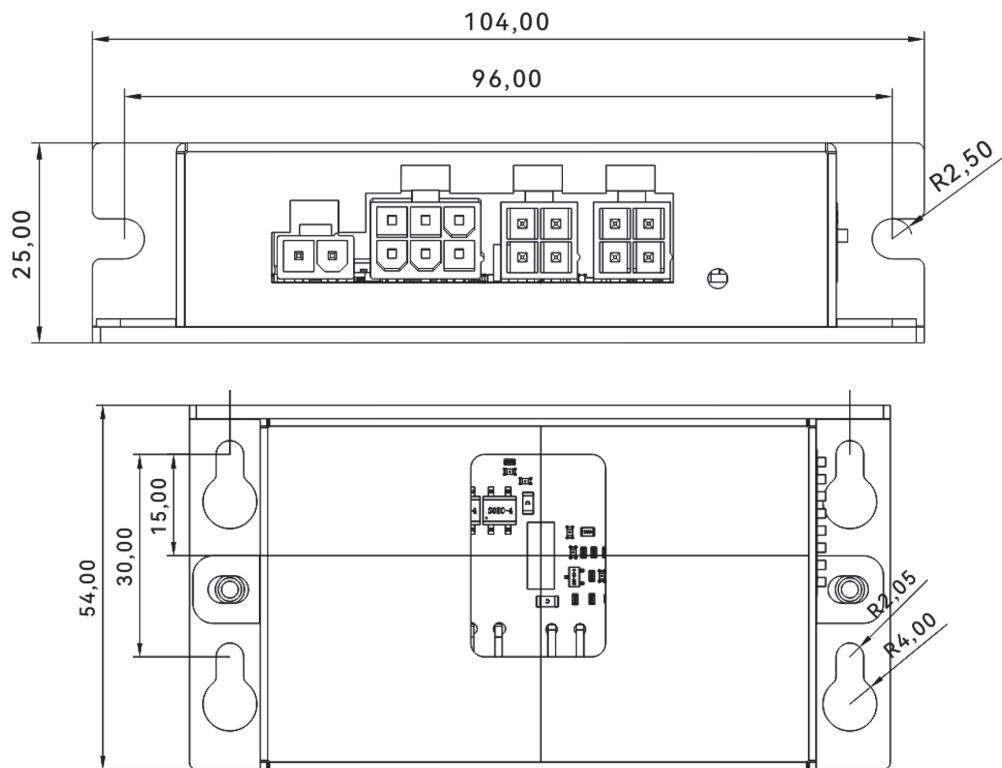

Infrared receivingboard size:

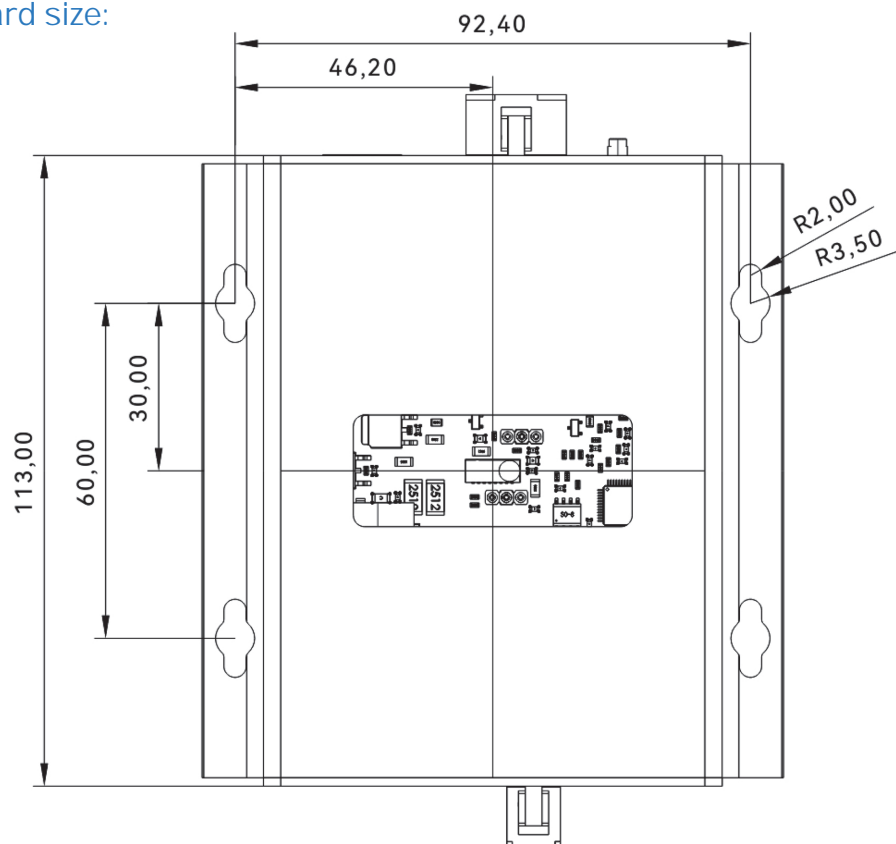

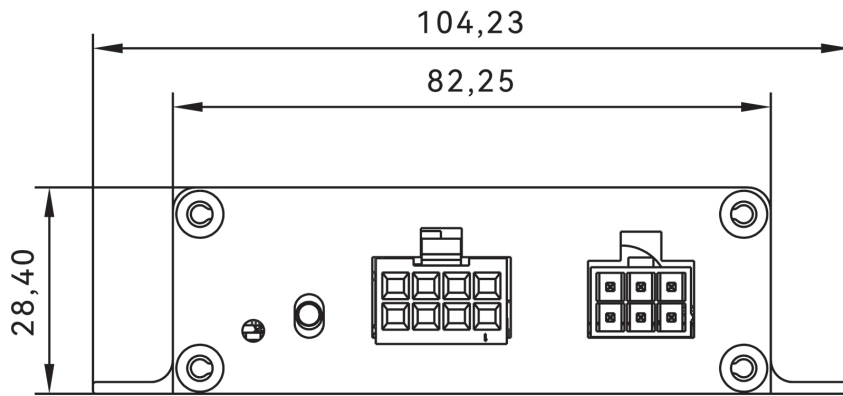

## Terminal definition and signal indication

### Infrared transmitting board terminal diagram

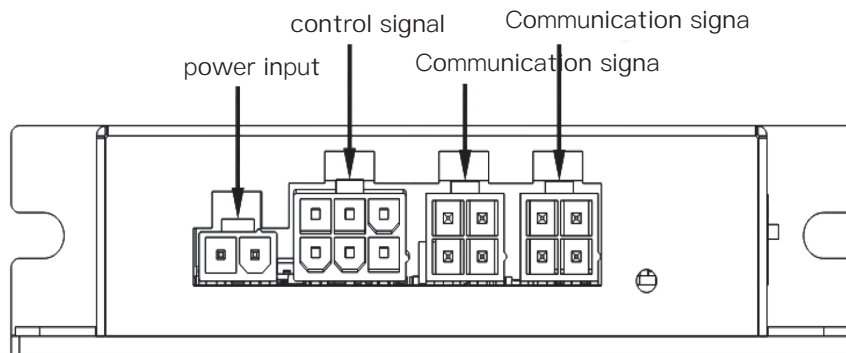

Figure 2.1 IR transmitter terminal signal 1

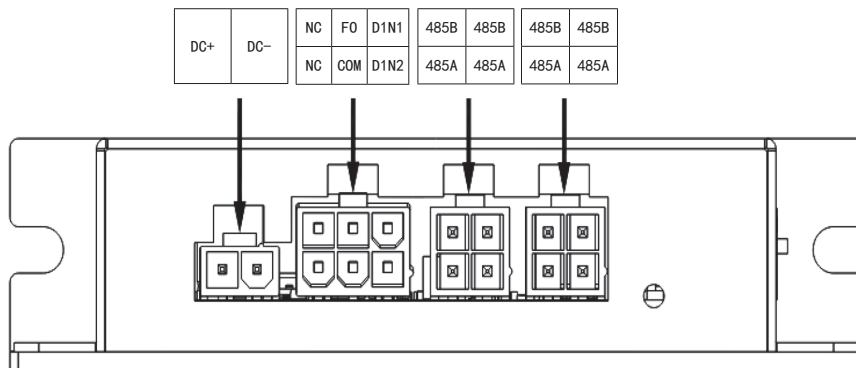

Figure 2.2 IR transmitter terminal signal 2

# Infrared transmitting board terminal diagram

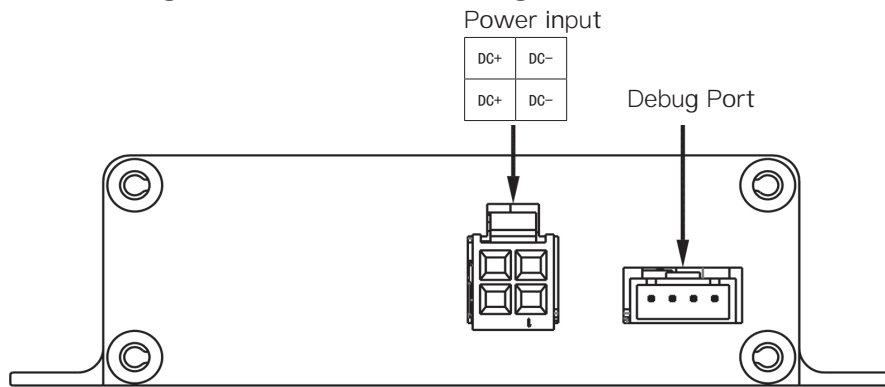

Figure 2.3 Infrared receiving board (drive) terminal signal 1

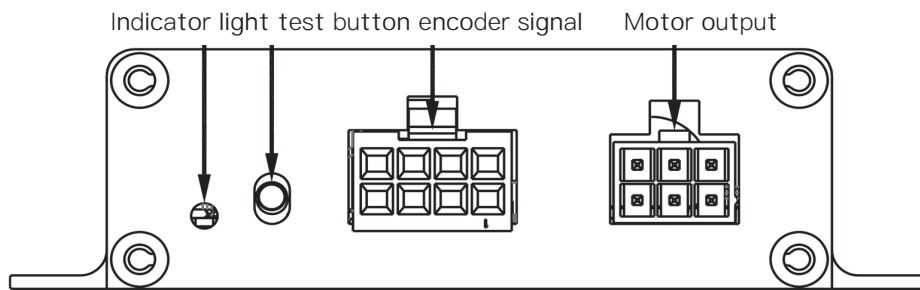

Figure 2.4 Infrared Receiver Board (Drive) Terminal signal 2

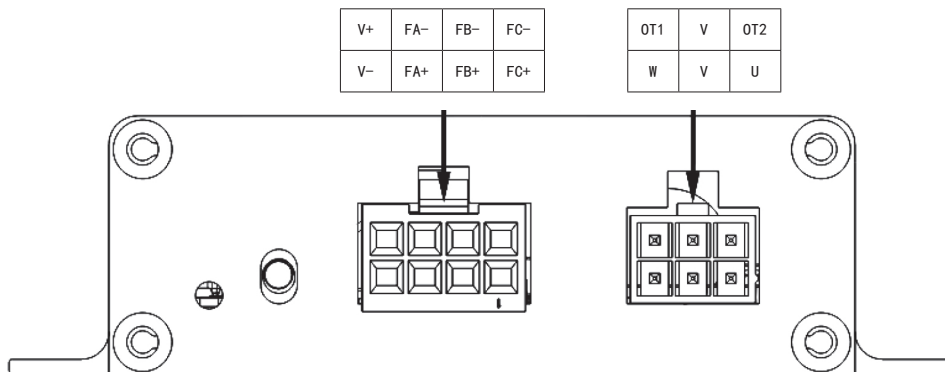
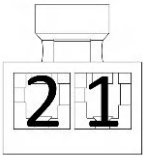



Figure 2.5 Infrared receiving board (drive) terminal signal 3

## Infrared emission plate terminal definition

### ④Description of the infrared transmitter power port

| port   | Model  | The pin order | The pin definition | Remark                                  |
|--|--|---------------|--------------------|---|
| Power input<br> | plug:<br>HX42000-02RN<br>(5557-02RN)<br>terminal:<br>HX42000-RT<br>(5556)<br>red star<br> | 2             | DC 24V+            | Positive input terminal of power supply |
|  |  | 1             | DC 24V-            | Negative input terminal of power supply |

This driver triggers operation through 10 signals, with DIN1 controlling the drum to rotate forward and DIN2 controlling the drum to reverse. The logic is as follows:

- The rising edge of DIN1 or DIN2 will trigger an operation, and it is recommended that the high level duration be greater than 5ms;
- After detecting the rising edge, the driver will run for a set distance and stop, as shown in Figure 2.6;
- If there is no clear zero situation, the system will not run, as shown in Figure 2.7;

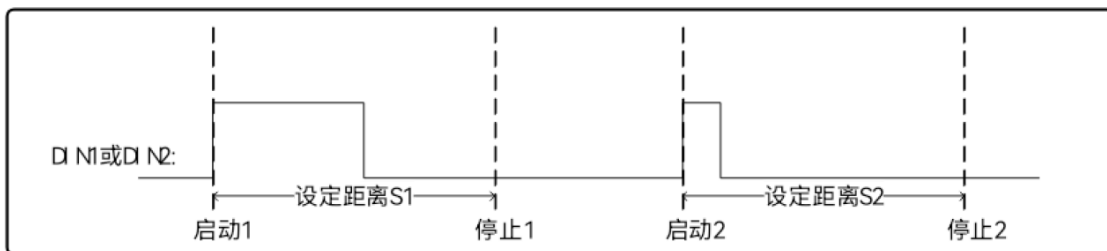

Figure 2.6 Zero Clearing signal after operation and run again

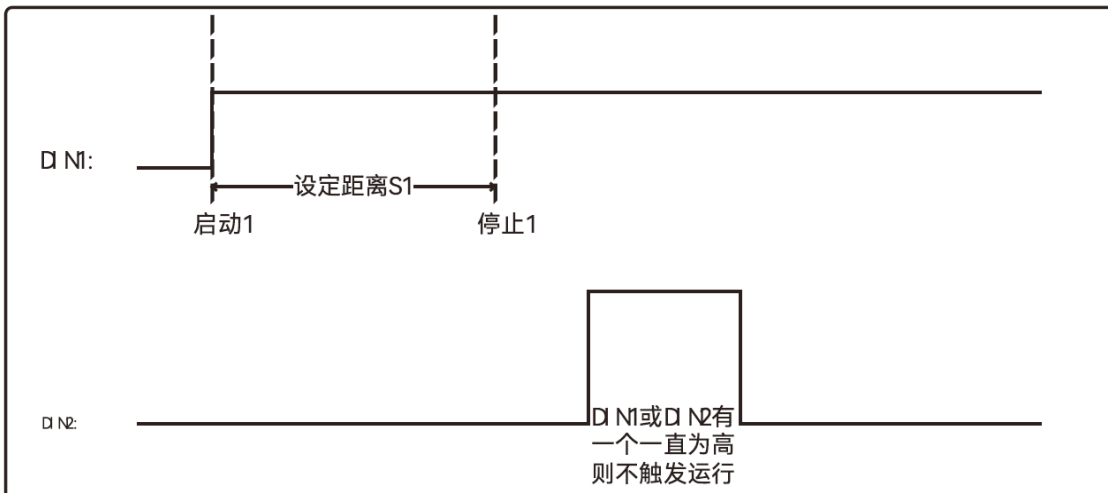





Figure 2.6 No zero clearing, no response

### ⊙ Infrared emission board control signal port description

| Port   | Model  | Pin order | Pin Definition | Remark            |
|--|--|-----------|----------------|-------------------|
| Control signal port<br> | plug: 42000-06R (5557-06R)<br>terminal: HX42000-RT (5556)<br>Red Star<br> | 2         | COM            | common port       |
|  |  | 3         | NC             | Empty pin         |
|  |  | 6         |                |                   |
|  |  | 4         | DIN1           | Forward running   |
|  |  | 1         | DIN12          | Reverse operation |
|  |  | 5         | FO             | Failure output    |

### ⊙ Infrared transmitter communication signal port description

| Port   | Model  | Pin order | Pin Definition | Remark                      |
|--|--|-----------|----------------|-----------------------------|
| Communication signal port<br> | plug: HX42000-04R (5557-04R)<br>terminal: HX42000-RT (5556)<br>Red Star<br> | 1         | RS485A         | Communication signal RS485A |
|  |  | 2         | RS485A         | Communication signal RS485A |
|  |  | 3         | RS485B         | Communication signal RS485B |
|  |  | 4         | RS485B         | Communication signal RS485B |

Note: An infrared transmitter has two sets of communication signal ports.

### ⊙ Dip switch port -RS485 operating mode

| Port  | Model            | Pin order |                     | Remark   |
|---|------------------|-----------|---------------------|--|
| Dip switch<br> | 8-bit Dip switch | 1         | 1                   | 1. Drive address code: $Add = X1 \cdot 1 + X2 \cdot 2 + X3 \cdot 4 + X4 \cdot 8 + X5 \cdot 16$<br>$X1 \sim 5$ is switch status |
|   |                  | 2         | 2                   |  |
|   |                  | 3         | 4                   |  |
|   |                  | 4         | 8                   |  |
|   |                  | 5         | 16                  |  |
|   |                  | 6         | reserve             |  |
|   |                  | 7         | reserve             |  |
|   |                  | 8         | terminal resistance | ON: Terminal resistance is valid<br>OFF: Terminal resistance is invalid  |

### ⊙Dip switch interface -I/O running mode



| Port       | Model   | Pin order | Pin Definition      | Remark   |
|------------|---|-----------|---------------------|--|
| Dip switch | 8-bit Dip switch<br> | 1         | X1                  | 1. Drive address code: Add=X1*1+X2*2+X3*4+X4*8+X5*16X15 is switch status |
|            |   | 2         | X2                  |  |
|            |   | 3         | X3                  |  |
|            |   | 4         | X4                  |  |
|            |   | 5         | X5                  | reserve  |
|            |   | 6         | reserve             |  |
|            |   | 7         | reserve             | ON: Terminal resistance is valid   |
|            |   | 8         | terminal resistance | OFF: Terminal resistance is invalid                                      |

### Infrared receiver board (driver) terminal definition



#### ⊙Description of power input ports on the infrared receiving board (driver)

| Port        | Model   | Pin order | Pin Definition | Remark                                  |
|-------------|---|-----------|----------------|---|
| Power input | HX42000-04R<br>(5557-04R)<br>terminal:<br>HX42000-RT<br>(5556)<br>red star<br> | 1         | DC 48V+        | Positive input terminal of power supply |
|             |   | 2         |                |   |
|             |   | 3         | DC 48V-        | Negative input terminal of power supply |
|             |   | 4         |                |   |

## Motor output port description

| Port   | Model   | Pin order | Pin Definition | Remark                         |
|--|---|-----------|----------------|--------------------------------|
| Motor output port<br> | plug: 42000-06R<br>(5557-06R)<br>terminal:<br>HX42000-RT<br>(5556)<br>Red Star<br> | 1         | U              | Motor UVW phase line           |
|  |   | 2         | V              |                                |
|  |   | 5         |                |                                |
|  |   | 3         | W              | TCMotor thermal protection PTC |
|  |   | 4         | OT2            |                                |
|  |   | 6         | OT1            |                                |

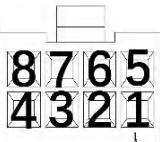
## Encoder Signal Port Description

| Port   | Model   | Pin order | Pin Definition | Remark                          |
|--|---|-----------|----------------|---------------------------------|
| Encoder Signal Port<br> | plug: 42000-08R<br>(5557-08R)<br>terminal:<br>HX42000-RT<br>(5556)<br>Red Star<br> | 1         | FC+            | Encoder differential signal FC+ |
|  |   | 2         | FB+            | Encoder differential signal FB+ |
|  |   | 3         | FA+            | Encoder differential signal FA+ |
|  |   | 5         | FC-            | Encoder differential signal FC- |
|  |   | 6         | FB-            | Encoder differential signal FB- |
|  |   | 7         | FA-            | Encoder differential signal FA- |
|  |   | 4         | V-             | Encoder signal power supply     |
|  |   | 8         | V+             |                                 |

test button:

- 1、 Press and hold the button, and after 500ms, the motor will rotate forward. Release the button and the motor will stop.
- 2、 Within 500ms, press the button first, release it, then press and hold the button to reverse the motor, and release the button to stop the motor.

## Signal indication

### Indicator light status in fault state

| No | Flash of indicator light   | Information description | Solution  |
|----|----------------------------|-------------------------|---|
| 1  | Flashing 1 times per cycle | Encoder failure         | Check the encoder cable and power it on again                                   |
| 2  | Flashing 2 times per cycle | Over temperature fault  | Over high temperature   |
| 3  | Flashing 3 times per cycle | Overcurrent fault       | Block the rotation or have too heavy load                                       |
| 4  | Flashing 4 times per cycle | Locked rotor fault      | Block the rotation or have too heavy load                                       |
| 5  | Flashing 5 times per cycle | Overload fault          | Block the rotation or have too heavy load                                       |
| 6  | Flashing 6 times per cycle | Low voltage failure     | If the voltage is below 25V, restore the voltage to above 30V.                  |
| 7  | Flashing 7 times per cycle | High voltage failure    | If the voltage is higher than 70V, reduce the voltage to below 65V and restore. |

### Indicator light status under normal state

| No | Flash of indicator light | Information description        | Remark   |
|----|--------------------------|--------------------------------|--|
| 1  | Version number flashing  | Version number                 | Power on and start flashing  |
| 2  | Cycle flashing           | The motor flashes at the speed | The flashing indicates that the correct instruction is received and executed |
| 3  | Keep bright              | standby state                  |  |

## Schematic diagram of the infrared emission plate wiring

In order to ensure better product performance, our product IO mode operation is compatible with both NPN wiring and PNP wiring. The following detailed below

### NPN wiring:

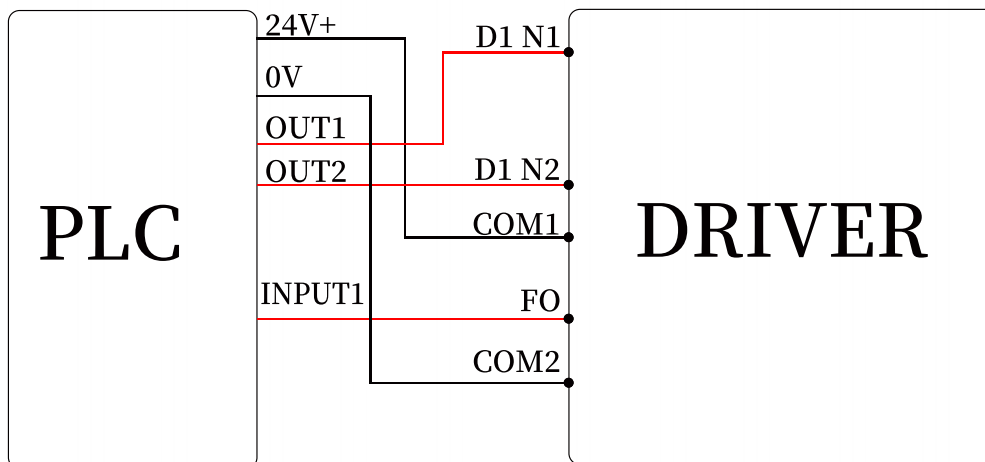

Drive external power supply NPN wiring

⊙ PNP connection method:

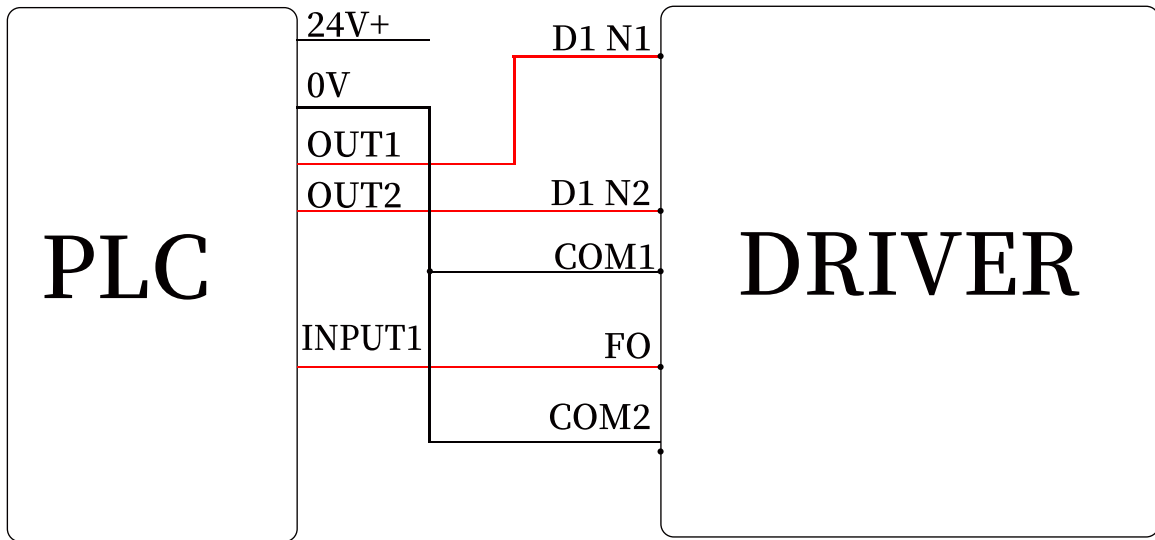

Drive PNP wiring

⊙ Communication control connection method:

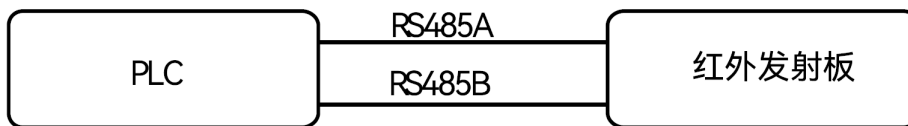

Drive communication line wiring

Attention: Please use star connection method for wiring;  
Please use twisted pair or shielded twisted pair;  
On site, please dial the end terminal resistance dial code or the end terminal resistance dial code on the RS485 bus according to the situation.  
Each RS485 bus can only dial up to two terminal resistors.  
Generally, each RS485 bus only needs to dial one terminal resistor. If you need to dial two terminal resistors, please contact the manufacturer for consultation.

## Attached: motor roller selection table

| Specific type and description of the motor roller |  |   |  |   |     |
|---|--|---|--|---|-----|
| Roller outer diameter                             | <input type="checkbox"/> 67            | <input type="checkbox"/> 50               | <input type="checkbox"/> 100                   | <input type="checkbox"/> Other  | mm  |
| Motor type  | <input type="checkbox"/> Non-inductive | <input type="checkbox"/> Brushless        | <input type="checkbox"/> servo                 |   |     |
| Roller length                                     |  |   |  |   | mm  |
| Drive mode  | <input type="checkbox"/> belt          | <input type="checkbox"/> Roller conveying | <input type="checkbox"/> Other                 |   |     |
| Length (transport gap)                            |  |   | If it is a belt conveyor                       |   |     |
| If it is a belt conveyor                          |  |   |  |   | rpm |
| Maximum speed                                     | rpm                                    |   |  |   |     |
| Load (single roller)                              | average                                |   | maximum  |   | Kg  |
| Voltage   | <input type="checkbox"/> 24±10%        | <input type="checkbox"/> 48±10%           | <input type="checkbox"/> 72±10%                | <input type="checkbox"/> 220±10%  | V   |
| Operating characteristics                         | continuous operation (S1)              | Intermittent operation (S2)               | Intermittent operation start/ stop frequency:: |   |     |
| Control method                                    | <input type="checkbox"/> RS485         | <input type="checkbox"/> IO               | <input type="checkbox"/> Other                 |   |     |
| The wire outlet length of roller                  | Brushless                              | ≤ 2000 (Total length)                     | servo  | ≤ 2500 (Total length)   | mm  |
| surface treatment                                 | <input type="checkbox"/> galvanization | <input type="checkbox"/> knurling         | <input type="checkbox"/> wire drawing          | <input type="checkbox"/> Encapsulation (please tell us the required material) |     |
| Protection level                                  | <input type="checkbox"/> dust proof    | <input type="checkbox"/> water proof      | <input type="checkbox"/> Remark                |   |     |
| Operating environment (temperature)               | Standard:-25℃ ~60℃                     |   |  | Other ℃   |     |
| Remark  |  |   |  |   |     |

### Product Application and Description

|   |   |  |  |
|---|---|--|--|
| <input type="checkbox"/> Cross belt trolley | <input type="checkbox"/> Weighing equipment | <input type="checkbox"/> Roller transmission | <input type="checkbox"/> Other (specific description required) |
| specific description:                       |   |  |  |



## **WINROLLER INTELLIGENT EQUIPMENT CO., LTD**

---

Tel : 400.780.5988

Website : [www.winroller.com](http://www.winroller.com)

Add : NO. 38, NORTH XIZHANG ROAD, HUIZHAN DIS,  
WUXI CITY, JIANGSU PROVINCE, CHINA