



Shanghai Shigan

Name: Mary

Tel: 0086 18069669221

E-mail: shigan7@checkweigher-sg.com

SG-150 Automatic checkweigher



Shanghai Shigan Industrial Co., Ltd. is a professional [automatic checkweigher manufacturer](http://www.online-checkweigher.com) and supplier. We have a professional team to independently develop and design checkweighers to solve your actual production problems!

Copyright © Shanghai Shigan Industrial Co., Ltd. All Rights Reserved
www.online-checkweigher.com



Shanghai Shigan

Name: Mary

Tel: 0086 18069669221

E-mail: shigan7@checkweigher-sg.com

Induction

The [automatic weight sorting machine](#) can accurately detect the unqualified products in the continuous production line, and perform the control of the upper and lower line discrimination or the automatic weight sorting according to this. The entire inspection does not change the original workflow of the packaging line. Packaging The products pass the checkweigher weighing test, the qualified ones will be sent back to the original conveyor belt, the unqualified ones will be rejected (or alarm shutdown), and it has the functions of classifying and counting the products according to the settings. The automatic weight sorting machine can save manpower, avoid unnecessary loss due to excessive packaging or customer complaints caused by insufficient weight, so as to improve customer satisfaction. It is a good quality inspection equipment for automatic production lines and packaging lines.





Shanghai Shigan

Name: Mary

Tel: 0086 18069669221

E-mail: shigan7@checkweigher-sg.com

Feature and advantage

1. Use imported special dynamic weighing unit to realize high-speed and stable measurement;
2. 10-inch large-size color touch screen interface, simple operation and intuitive display;
3. Fully automatic sorting method to avoid human error;
4. Automatic zero point analysis and tracking system to ensure stable detection;
5. Built-in temperature noise compensation system to ensure reliable data;
6. Powerful data statistics function, record daily inspection data, can store 100 sets of product data, convenient for customers to call, and sudden power failure data will not be lost;
7. The conveying system adopts frequency conversion speed regulation mode, which is convenient for front and rear speed coordination;
8. Dynamic weight compensation technology, the detection data is more real and effective;
9. Self fault diagnosis and prompt function, convenient for maintenance;
10. The reinforced stainless steel 304 frame is adopted, which conforms to GMP and HACCP specifications;
11. The simple mechanical structure can be quickly disassembled for cleaning and maintenance;
12. A variety of rejection devices are optional for customers: blow rejection, push rod rejection, shift rod rejection, drop rejection, etc.;
13. Data external communication interface, can be connected to other equipment in the production line (such as marking machine, inkjet printer, etc.), and peripheral USB interface, easy to realize data export and upload!



Shanghai Shigan

Name: Mary

Tel: 0086 18069669221

E-mail: shigan7@checkweigher-sg.com

Specification

Type: SG-150

Weighing range: 3-500g

Detection accuracy: $\pm 0.05\text{g}$ (detection accuracy is affected by product weight, product size, delivery mode, working environment, etc.)

Division Scale: 0.1g

Belt speed: 0-65 m/min

Large inspection speed: 150 PCS/min

Machine weight: 60kg

Pick out system: air blow pick out (other types can be customized)

Power supply: AC220V; 50 Hz; 1 p; 10 A

Case material: 304 stainless steel

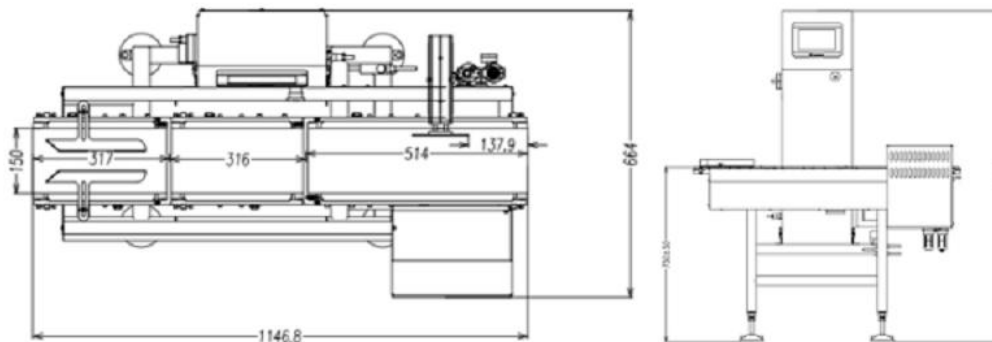

Copyright © Shanghai Shigan Industrial Co., Ltd. All Rights Reserved

www.online-checkweigher.com



Shanghai Shigan

Name: Mary

Tel: 0086 18069669221

E-mail: shigan7@checkweigher-sg.com

Application

It is mainly used for automatic weight detection, online and offline discrimination or weight classification selection on various automated packaging lines. It is widely used in online high-speed packaging checkweighing applications in pharmaceutical, food, health care products, daily chemicals, batteries, light industry and other industries.





Shanghai Shigan

Name:Mary

Tel:0086 18069669221

E-mail:shigan7@checkweigher-sg.com

Our Service

About price description:

1. Because the product specifications and models are different, the above prices are reference prices, and the specific prices are subject to customer service quotations.
2. Users who order in bulk can enjoy ultra-low discounts!

About quality description:

1. Replacement within seven days, warranty within one year and lifetime maintenance.) Before the product is sold, we will go through strict inspection to ensure that the product you sign for has no quality problems;
2. The products provided to customers are all produced by the original factory, and the factory materials and accessories are complete;
3. During the warranty period, our company will repair the parts damaged due to quality reasons for free, and the parts damaged outside the warranty period will only charge cost for the parts provided. If the equipment is damaged due to human factors, our company will repair or provide The accessories are calculated at cost.

About return and exchange instructions:

1. If there is a problem with the quality of the product itself (except for product deformation or damage caused by express delivery), the product can be returned and exchanged within seven days from the date of receipt, and the return postage will be borne by us!
2. The products sold by our company are all standard products. If you are not familiar with how to use the products, you can call us and we have professional technicians to answer you!
3. Once the product is sold, if there is no quality problem, such as special circumstances, it will not be returned!



Shanghai Shigan

Name: Mary

Tel: 0086 18069669221

E-mail: shigan7@checkweigher-sg.com

About payment method:

1. Support online transfer, WeChat, Alipay, door-to-door payment, regular manufacturers! Please rest assured to buy!

About billing instructions:

Customers who need to invoice can contact customer service!

About delivery instructions:

1. The products sold by the company are all genuine and licensed products, and are shipped in secondary packaging (the original packaging color box is added with a packaging carton or foam to prevent damage during express logistics)

Shanghai Shigan Industrial Co., Ltd. adopts advanced technology and advanced development concepts, constantly reforms and innovates, pursues excellent quality, provides the best automatic weighing solutions for various industries, and creates higher value for users. We also have a group of teams with high professional level, strong innovation ability and good service consciousness. The main products include automatic checkweighers, multi-stage checkweighers, metal detectors, etc. If you are interested in any of our automatic checkweigher. or would like to discuss a custom order, please feel free to [contact us](#).