

Theoborn factory reserve the right to change technical Characteristics without previous advice



The leading pneumatic valve enterprise of china

Theoborn auto-control valves co.,ltd



Theoborn auto-control valves co.,ltd

ADD: No. 119,4th road,3rd avenue,binhai industrial zone,economic and technical,Wenzhou,China.

P.C:325025

TEL:+86-577-86378000 86830000

FAX:+86-577-86887882

E-mail:tbn@theoborn.com

Http:www.theoborn.com

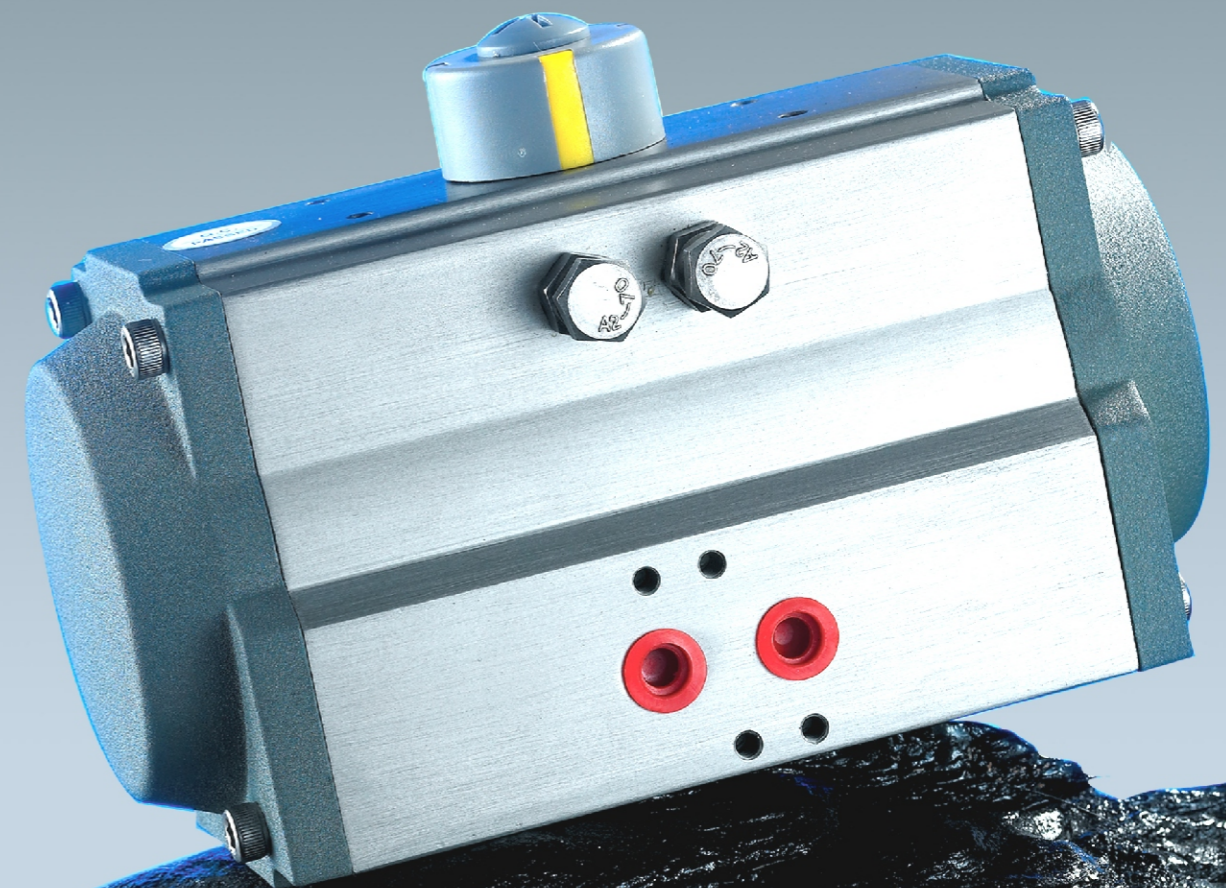



Consider people as a boat, consider seriousness as her helm,
and consider wisdom as her sail.

Brief Introduction

Theoborn Auto-control Valves Co., Ltd. is dedicated to manufacture pneumatic, electric, and hydraulic auto-driving equipment as well as all kinds of valves. Our products fundamentally transform the complex process of valves, greatly improving the efficient usage of valves, largely diminishing the controlling cost, and obtaining considerable profits for enterprises.

Theoborn Auto-control Valves Co., Ltd. is located in Wenzhou city which possess a long history of manufacturing valves and pumps. Inspired by centuries-old experience of manufacturing valves and pumps, supported by exquisite manufacturing technique, and enveloped with the special innovative consciousness and serious spirit, Theoborn endeavors to culminate the wisdom, aspires to make the best products, and desires to benefit human beings.

Theoborn people believe that we should: consider people as a boat, consider wisdom as her helm, and consider seriousness as her sail. Theoborn believes that: professional technology, along with the sincere service, will obtain customer's heart, win custom's credits, and move customers.

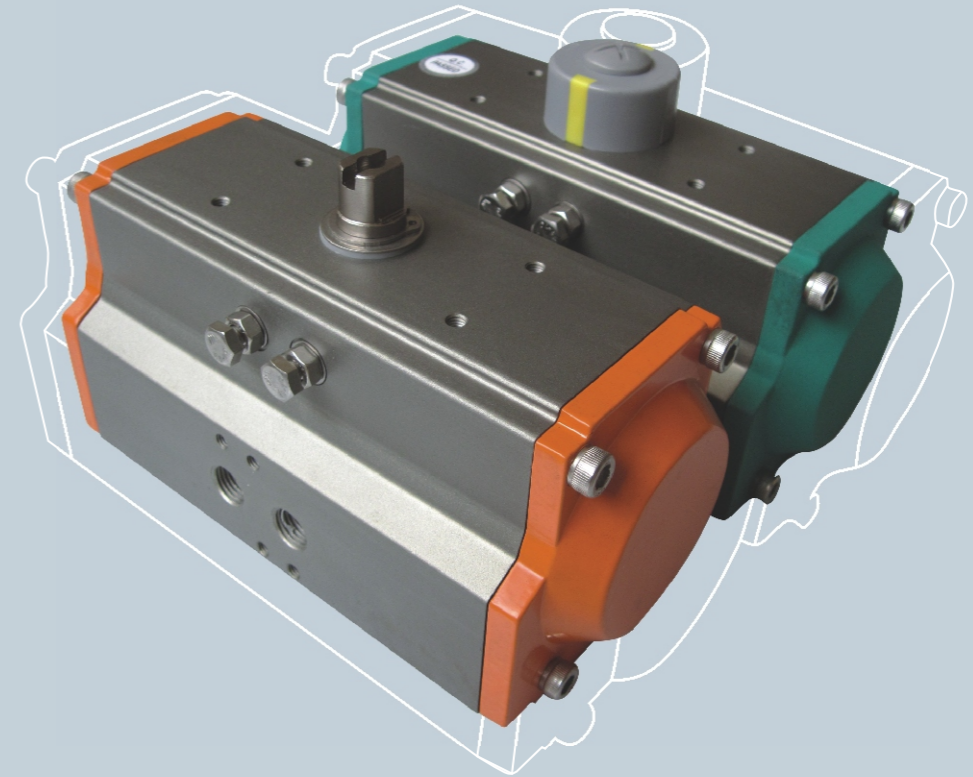

THEOBORN

Theoborn auto-control valves co.,ltd



Pneumatic Actuator

Model preparation

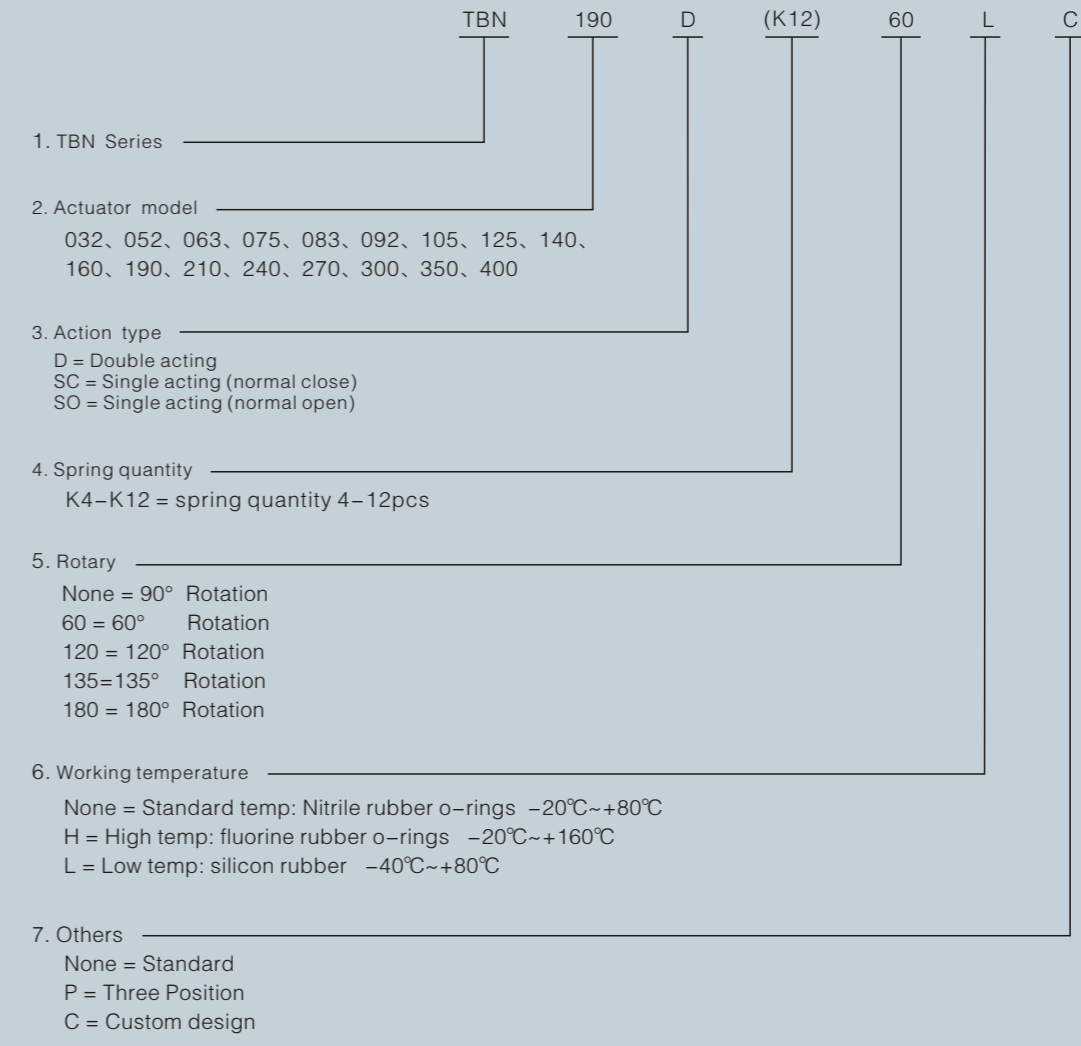

Parts and materials

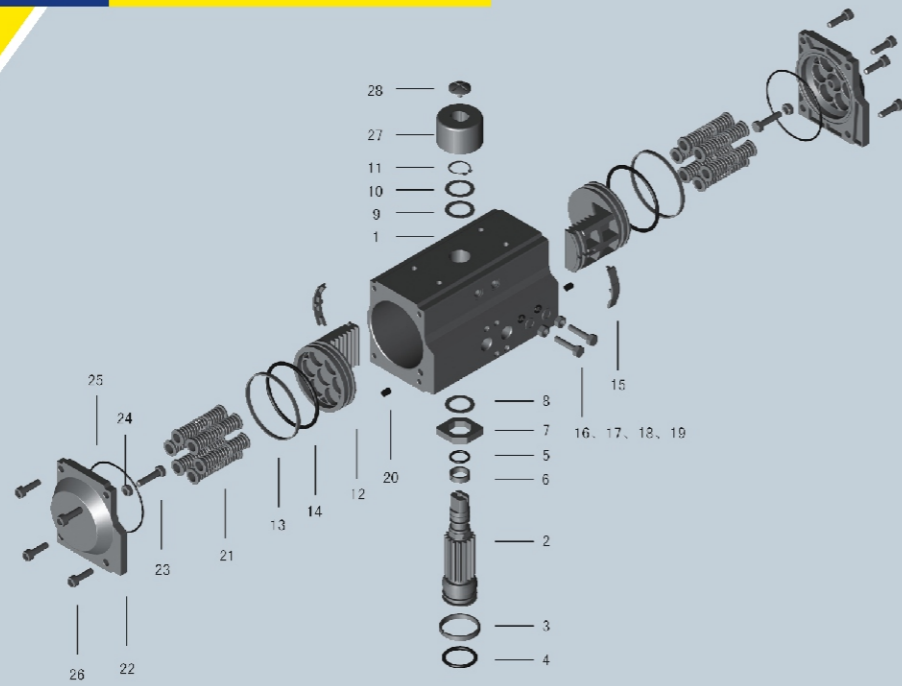

NO.	Description	Qty	Material	Protection
1	Cylinder	1	Aluminum Alloy	Anodized Oxygenation
2	Pinion	1	Carbon steel	Nickel Plated
3	Bearing(Lower Pinion)	1	POM	
4	O-Ring(Lower Pinion)	1	NBR	
5	O-Ring(Top Pinion)	1	NBR	
6	Bearing(Top Pinion)	1	POM	
7	Spacer	1	Carbon steel	phosphatized /galvanized
8	Thrust Bearing Pinion	1	Alloy Steel	
9	Thrust Bearing Pinion	1	POM	
10	Thrust Washer(Pinion)	1	Stainless Steel	
11	Spring Clip	1	Stainless Steel	
12	Piston	2	Aluminum Alloy	Anodized Oxygenation
13	Guide Ring(Piston)	2	POM	
14	O-Ring(Piston)	2	NBR	
15	Bearing Ring(Piston)	2	POM	
16	Adjusting Screw	2	Stainless Steel	
17	Adjusting Nut	2	Stainless Steel	
18	Washer(Adjusting Screw)	2	Stainless Steel	
19	O-Ring(Adjusting Screw)	2	NBR	
20	Plug	2	NBR	
21	Spring	4~12	Spring Steel	electrophoresis painted Epoxy coated
22	End Cap	2	Aluminum Alloy	Epoxy Coated
23	Adjusting Screw(End Cap)	2	Stainless Steel	
24	Adjusting Nut(End Cap)	2	Stainless Steel	
25	O-Ring(End Cap)	2	NBR	
26	Bolts(End Cap)	8	Stainless Steel	
27	Indicator	1	Engineering Plastics	
28	Nut(Indicator)	1	Engineering Plastics	

Note: Viton O-ring for high temperature application, and silicone rubber O-ring for low temperature application.

External Connection Dimension

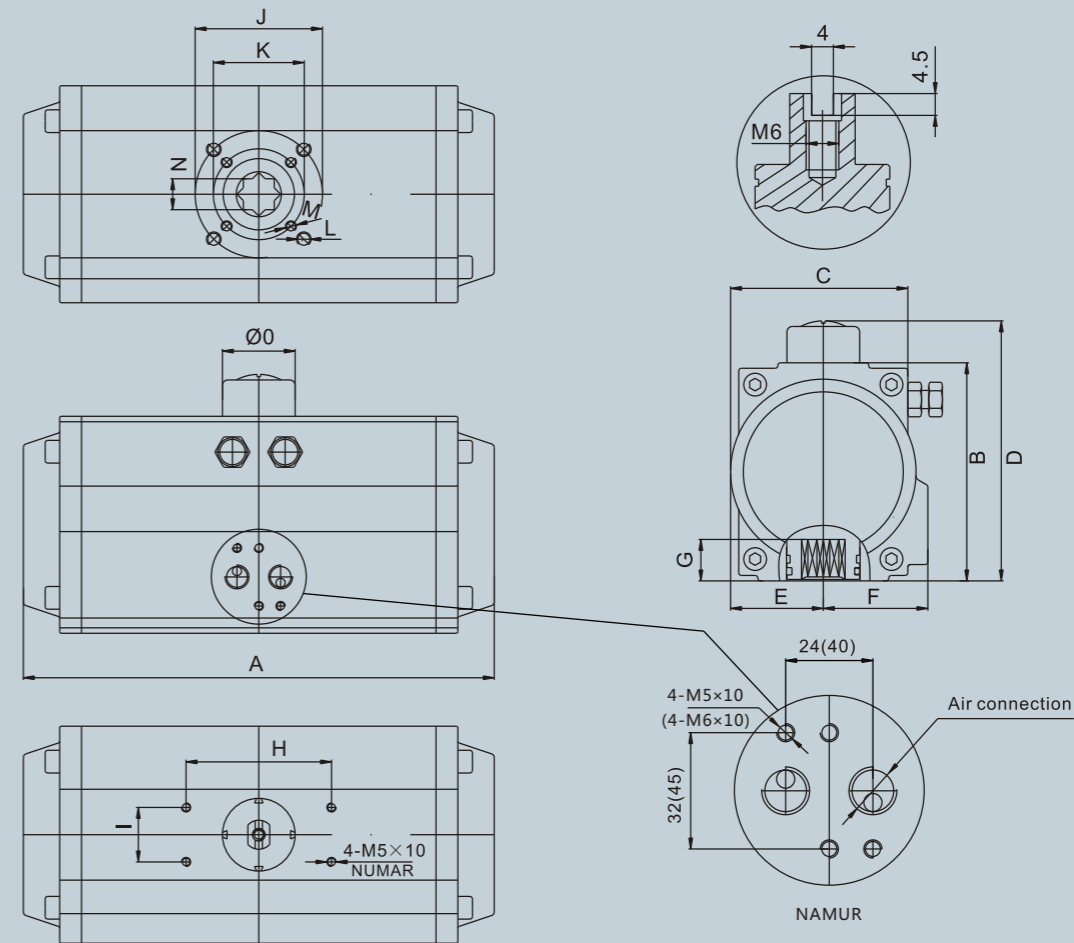

Model	A	B	C	D	E	F	G	H	I	J	K	L	M	N	Φ0	Air
TBN032	114	46	47	70	23.5	23.5	11	50	25		F03 Φ36		M5×8	9	30	G1/8
TBN052	158	74	60	99	30	41	14	80	30	F05 Φ50	F03 Φ36	M6×11	M5×10	11	40	G1/4
TBN063	190	88	69	113	36	45	18	80	30	F07 Φ70	F05 Φ50	M8×15	M6×12	14	40	G1/4
TBN075	206	100	79	125	42	52	20	80	30	F07 Φ70	F05 Φ50	M8×13	M6×11	14	40	G1/4
TBN083	213	109	88	134	46	52.5	20	80	30	F07 Φ70	F05 Φ50	M8×15	M6×12	17	40	G1/4
TBN092	259	120	97.5	145	51	57.5	22	80	30	F07 Φ70	F05 Φ50	M8×13	M6×12	17	40	G1/4
TBN105	284	133	105.5	158	57.5	64	24	80	30	F10 Φ102	F07 Φ70	M10×18	M8×14	22	40	G1/4
TBN125	340	155	120.5	182	67.5	70	27.5	80	30	F10 Φ102	F07 Φ70	M10×18	M8×14	22	65	G1/4
TBN140	414	171.5	137	198	76	77	32	80	30	F12 Φ125	F10 Φ102	M12×22	M10×18	27	65	G1/4
TBN160	476	197	159.5	224	86.5	87.5	34	80	30	F12 Φ125	F10 Φ102	M12×22	M10×18	27	65	G1/4
TBN190	524	230	186	269	103	103	40	130	30	F14 Φ140		M16×23		36	78	G1/4
TBN210	559	255	202	294	113	113	40	130	30	F14 Φ140		M16×25		36	78	G1/4
TBN240	668	291	233	330	129	129	50	130	30	F16 Φ165		M20×28		46	78	G3/8 (1/4)
TBN270	744	320	264	359	146	146	57	130	30	F16 Φ165		M20×28		46	78	G1/2 (1/4)
TBN300	830	362	312.5	402	194.5	194.5	57	130	30	F25 Φ254	F16 Φ165	M16×24	M20×28	46	78	G1/2
TBN350	920	413	353.5	453	221.5	221.5	60	130	30	F25 Φ254	F16 Φ165	M16×24	M20×28	55	95	G1/2
TBN400	1012	465	391	505	248	248	60	130	30	F25 Φ254	F16 Φ165	M16×24	M20×28	55	95	G1/2

Output torque of single acting actuator

Unit:Nm

		Output Torque of Air supply										Output Torque of spring		
Air pressure (bar)		3		4		5		6		7		0°	90°	
Model	Spring quantity	0° origin	90° End	0° origin	90° End	0° origin	90° End	0° origin	90° End	0° origin	90° End	End	origin	
TBN052S	5	7.8	5.3	11.6	8.9							3.8	6.1	
	6	7.1	4.2	10.9	7.8							4.6	7.4	
	7	6.4	3.2	10.2	6.7							5.2	8.5	
	8			9.5	5.7	13.3	9.3					6.0	9.7	
	9			8.8	4.6	12.6	8.2					6.7	11.0	
	10			8.0	3.5	11.9	7.1	15.7	10.7			7.5	12.2	
	11					11.1	6.0	15.0	9.6	18.8	13.1	8.3	13.4	
	12					10.4	5.0	14.2	8.6	18.1	12.1	9.0	14.6	
	TBN063S	5	14.6	9.3	21.6	15.4	28.7	21.4					6.2	11.0
		6	13.1	7.5	20.2	13.5	27.3	19.7					7.6	13.1
		7	11.6	5.7	18.8	11.8	25.9	17.8					8.8	15.3
		8			17.5	10.0	24.5	16.0	31.6	22.1			10.1	17.6
9				16.0	8.2	23.2	14.3	30.3	20.4			11.3	19.7	
10				14.8	6.4	21.9	12.5	29.0	18.5	36.1	24.6	12.5	21.9	
11				13.4	4.6	20.5	10.7	27.5	16.8	34.6	22.8	13.8	24.1	
12						19.1	8.9	26.2	14.9	33.3	21.0	15.0	26.3	
TBN075S		5	22.7	16.0	34.0	26.6							11.3	17.5
		6	20.5	12.9	31.8	23.4							13.5	21.0
		7	18.1	9.7	29.5	20.3							15.8	24.5
		8			27.2	17.1	38.6	27.7					18.1	28.0
	9			24.9	14.0	36.4	24.6					20.2	31.5	
	10			22.6	10.8	34.0	21.4	45.4	32.0	56.8	42.6	22.5	35.0	
	11					31.7	18.3	43.1	28.8	54.5	39.4	24.8	38.5	
	12					29.5	15.1	40.8	25.7	52.3	36.3	27.0	42.0	
	TBN083S	5	28.7	20.9	42.9	34.2							13.8	21.3
		6	26.1	17.2	40.3	30.4							16.5	25.5
		7	23.4	13.3	37.5	26.6							19.3	29.8
		8			34.8	22.8	48.9	36.2					22.0	34.0
9				32.1	18.9	46.2	32.3					24.8	38.3	
10				29.4	15.1	43.5	28.5	57.7	41.9	71.7	55.2	27.6	42.5	
11						40.8	24.7	55.0	38.1	69.0	51.4	30.3	46.7	
12						38.1	20.9	52.3	34.1	66.3	47.5	33.1	51.1	
TBN092S		5	43.2	32.5	65.0	54.2							21.9	32.7
		6	38.9	26.0	60.6	47.7							26.3	39.2
		7	34.5	19.4	56.2	41.1							30.7	45.8
		8			51.8	34.6	73.5	56.3					35.1	52.3
	9			47.4	28.1	69.1	49.8					39.5	58.8	
	10			43.0	21.5	64.8	43.3	86.5	65.0	108.2	86.7	43.9	65.4	
	11					60.4	36.7	82.1	58.4	103.8	80.2	48.2	71.9	
	12					56.0	30.2	77.7	51.9	99.4	73.6	52.6	78.4	
	TBN105S	5	64.7	44.2	97.7	74.0							29.9	48.8
		6	58.4	35.7	91.4	65.5							35.9	58.6
		7	52.1	27.3	85.2	57.0							41.9	68.3
		8			78.9	48.5	110.0	76.5					47.8	78.1
9				72.6	40.3	103.6	68.3					53.8	87.6	
10				66.4	31.6	97.4	59.6	129.5	88.4	161.4	117.3	59.8	97.6	
11						91.2	51.1	123.2	79.9	155.0	108.8	65.7	107.4	
12						84.9	42.7	116.8	71.5	148.9	100.4	71.7	117.1	
TBN125S		5	110.9	45.8	166.8	128.7							52.3	83.4
		6	99.5	37.0	155.4	113.4							62.7	100.1
		7	88.1	28.2	144.1	98.2							73.1	116.7
		8			132.7	82.9	188.6	134.2					83.6	133.4
	9			121.2	67.6	177.2	118.9					94.1	150.1	
	10			109.8	52.3	165.8	103.6	221.8	154.9			104.5	166.8	
	11					154.5	88.4	210.4	139.7	266.4	191.0	114.9	183.5	
	12					143.0	73.0	199.0	124.3	254.9	175.6	125.4	200.2	
	TBN140S	5	166.0	118.1	249.4	197.1							79.7	125.4
		6	149.2	94.3	232.6	173.3							95.6	150.5
		7	127.2	70.6	215.7	149.6							111.5	175.6
		8			198.9	125.8	282.2	204.8					127.4	200.6
9				182.1	102.1	265.4	181.0					143.4	225.7	
10				165.3	78.3	248.6	157.2	331.9	236.2	415.9	315.1	159.3	250.8	
11						231.8	133.5	315.1	212.4	398.5	291.4	175.2	275.9	
12						215.0	109.7	298.3	188.6	381.7	267.7	191.2	301.0	

Output torque of single acting actuator

Unit:Nm

		Output Torque of Air supply										Output Torque of spring		
Air pressure (bar)		3		4		5		6		7		0°	90°	
Model	Spring quantity	0° origin	90° End	0° origin	90° End	0° origin	90° End	0° origin	90° End	0° origin	90° End	End	origin	
TBN160S	5	254.0	185.3	382.4	311.0							124.2	191.8	
	6	227.8	146.8	356.2	272.5							149.1	230.2	
	7	201.6	108.5	330.0	234.2							173.9	268.6	
	8	175.4	71.8	303.7	195.8	432.1	321.4					198.7	306.9	
	9			277.5	157.5	405.9	283.1					223.6	345.3	
	10			251.3	119.1	379.7	244.8	508.0	370.5			248.4	383.6	
	11					353.5	206.4	481.8	332.1	610.2	457.8	273.3	422.0	
	12					327.3	168.1	455.6	293.8	584.0	419.4	298.1	460.3	
	TBN190S	5	411.8	288.4	618.7	482.3							195.7	309.7
		6	370.1	229.7	577.0	423.6							234.8	371.6
		7	328.3	171.0	535.2	365.0							274.0	433.6
		8			493.4	306.3	700.3	500.2					313.1	495.5
9				451.8	247.6	658.7	441.5					352.2	557.5	
10				410.0	188.9	616.9	382.9	823.8	576.8	1030.7	770.8	391.3	619.4	
11						575.1	324.2	782.0	518.1	988.9	712.1	430.5	681.3	
12						533.4	265.5	740.3	459.5	947.1	653.4	469.6	743.3	
TBN210S		5	566.0	409.8	850.3	685.1							268.9	420.9
		6	508.6	326.5	792.9	602.4							322.7	505.1
		7	451.3	243.2	735.6	518.6							376.5	589.3
		8			678.1	435.3	962.4	694.0					430.3	673.4
	9			620.8	349.2	905.1	624.6					484.0	760.5	
	10			563.4	268.8	847.7	544.1	1131.9	819.5	1416.2	1094.9	537.8	841.8	
	11					790.3	460.8	1074.5	736.2	1358.8	1011.6	591.7	926.0	
	12					733.0	377.6	1017.2	653.0	1301.5	928.3	645.3	1010.1	
	TBN240S	5	878	656	1414	1097							431	653
		6	788	523	1229	963							518	783
		7	700	389	1141	830							603	914
		8			1052	697	1493	1138					690	1045
9				963	563	1404	1004					776	1175	
10				874	430	1315	871	1756	1312	2197	1753	862	1306	
11						1226	738	1667	1179	2108	1619	948	1436	
12						1137	604	1578	1045	2019	1486	1034	1567	
TBN270S		5	1235	932	1855	1559							612	918
		6	1110	743	1730	1369							735	1101
		7	984	553	1605	1180							857	1285
		8			1479	990	2100	1617					980	1469
	9			1354	801	1974	1428					1102	1652	
	10			1324	611	1849	1238	2469	1865	3089	2491	1225	1836	
	11					1724	1049	2344	1675	2964	2302	1347	2019	
	12					1599	859	2219	1486	2839	2112	1470	2203	
	TBN300S	5	1521	1069									729	1143
		6	1379	885									874	1370
		7	1237	701	1983	1366							1019	1598
		8	1095	515	1840	1181	2585	1846					1165	1827
9				1697	997	2442	1662	3187	2326			1311	2054	
10				1555	811	2300	1476	3045	2141	3790	2805	1456	2284	
11						2158	1291	2903	1956	3647	2621	1602	2511	
12						2015	1107	2760	1771	3506	2436	1748	2740	
TBN350S		5	2319	1629									1072	1716
		6	2078	1308									1286	2059
		7	1837	986	3013	2066							1500	2402
		8	1594	664	2770	1744	3946	2824					1715	2746
	9			2528	1423	3704	2503	4879	3582			1930	3088	
	10			2288	1101									

Output torque of double acting actuator

Model	Air pressure (Bar)						
	2	3	4	5	6	7	8
TBN032D	2.7	4.1	5.9	7.4	8.8	9.8	11.3
TBN052D	7.7	11.6	15.5	19.3	23.2	27.1	31.0
TBN063D	13.8	20.6	27.5	34.4	41.3	48.2	55.0
TBN075D	22.3	33.7	44.7	55.9	67.0	78.2	89.3
TBN083D	28.2	42.3	56.4	70.5	84.6	98.7	112.9
TBN092D	43.2	64.8	86.5	108.0	129.6	151.2	172.8
TBN105D	63.1	94.7	127.2	157.8	189.4	220.9	252.5
TBN125D	108.4	162.7	216.9	271.1	325.3	379.5	433.8
TBN140D	163.2	244.8	326.4	408.0	489.6	571.2	652.8
TBN160D	251.4	377.0	502.7	628.4	754.1	879.7	1005.4
TBN190D	405.1	607.7	810.2	1012.8	1215.3	1417.9	1620.4
TBN210D	557	835	1113	1392	1670	1948	2227
TBN240D	873	1309	1745	2182	2618	3054	3491
TBN270D	1227	1841	2454	3068	3681	4295	4908
TBN300D	1506	2259	3013	3766	4519	5272	6024
TBN350D	2255	3382	4510	5638	6765	7893	9020
TBN400D	3213	4819	6427	8033	9640	11246	12853

Unit:Nm

Operating function and direction of rotation

Double acting

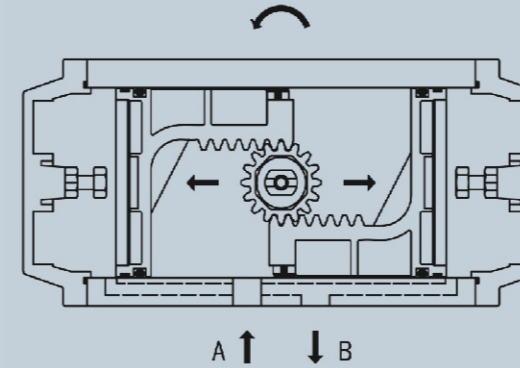

Air from Port A forces the pistons outwards, causing the springs to compress, the pinion turns counter-clockwise to open the valve while air is being exhausted from Port B.

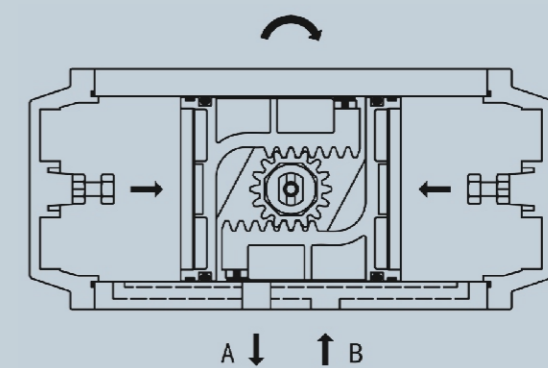

Air from Port B forces the pistons inwards, causing the springs to compress, the pinion turns clockwise to close the valve while air is being exhausted from Port A.

Single acting(FC)

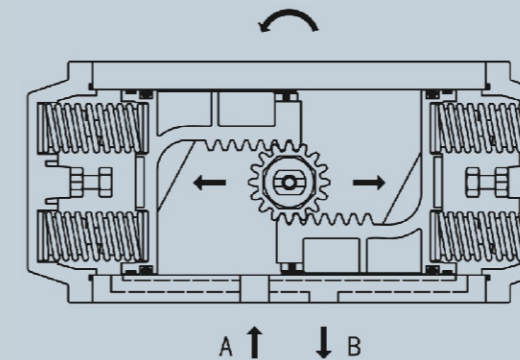

Air from Port A forces the pistons outwards, causing the spring to compress, the pinion turns counter-clockwise to open the valve while air is being exhausted from Port B.

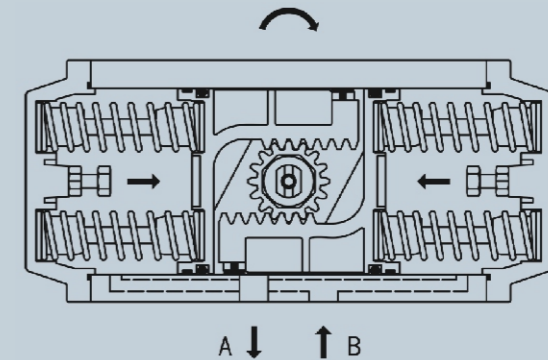

In case of air or power disruption, the rebound of springs forces the pistons inwards, the pinion turns clockwise to close the valve while air is being exhausted from Port A. Air from Port B can accelerate the close of the valve.

Note: 1. For double acting actuator, the standard rotation is clockwise for closing and counterclockwise for opening. If the assembly direction of the piston is reversed, then the rotation will be counter clockwise for closing and clockwise for opening.
 2. For single acting actuator, the standard is fail close type (FC), as shown above. If the assembly direction of the piston is reversed, then it will be fail open type (FO).

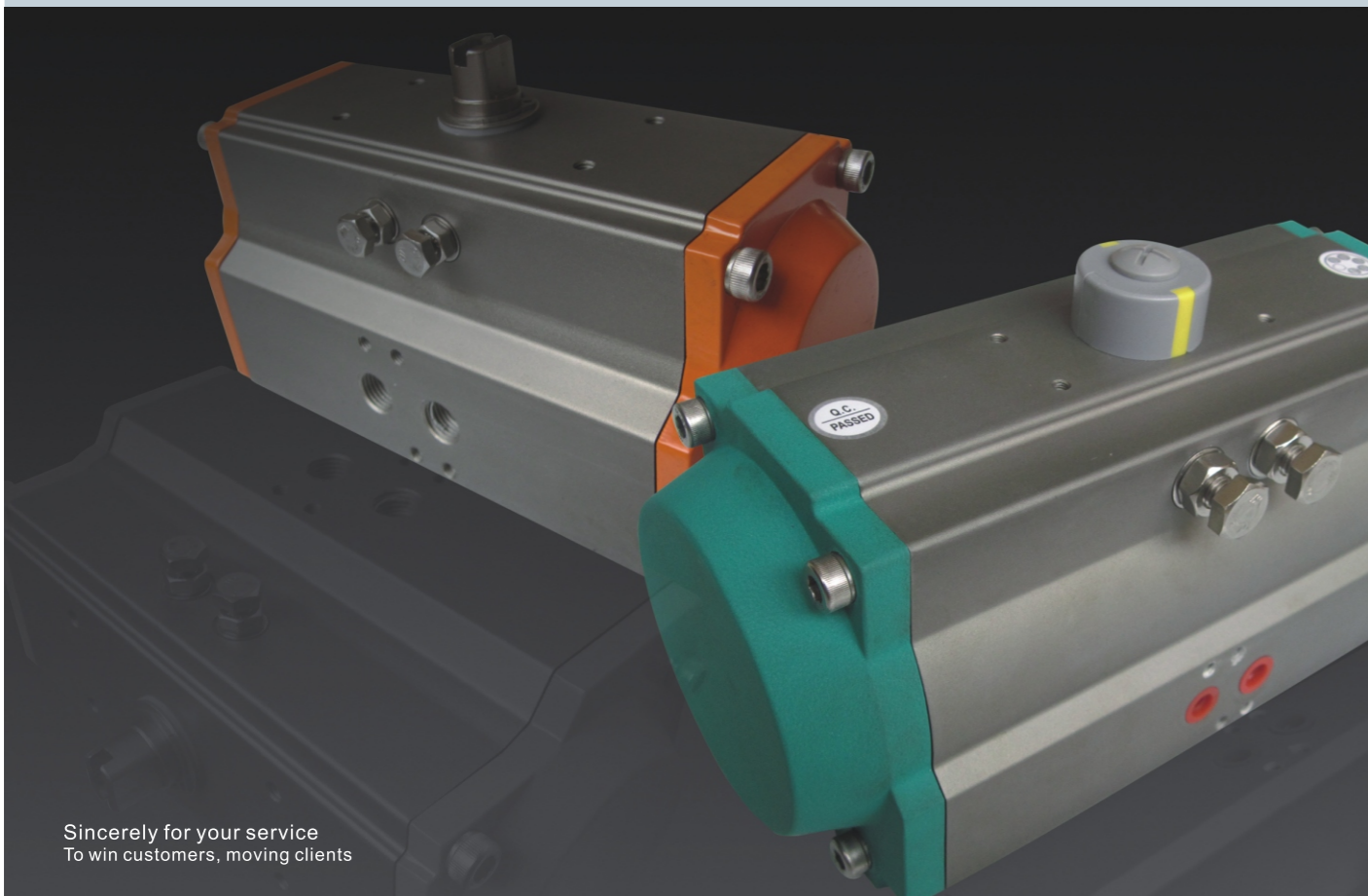

Sincerely for your service
To win customers, moving clients