

以人为舟，以严肃为舵，以智慧为帆

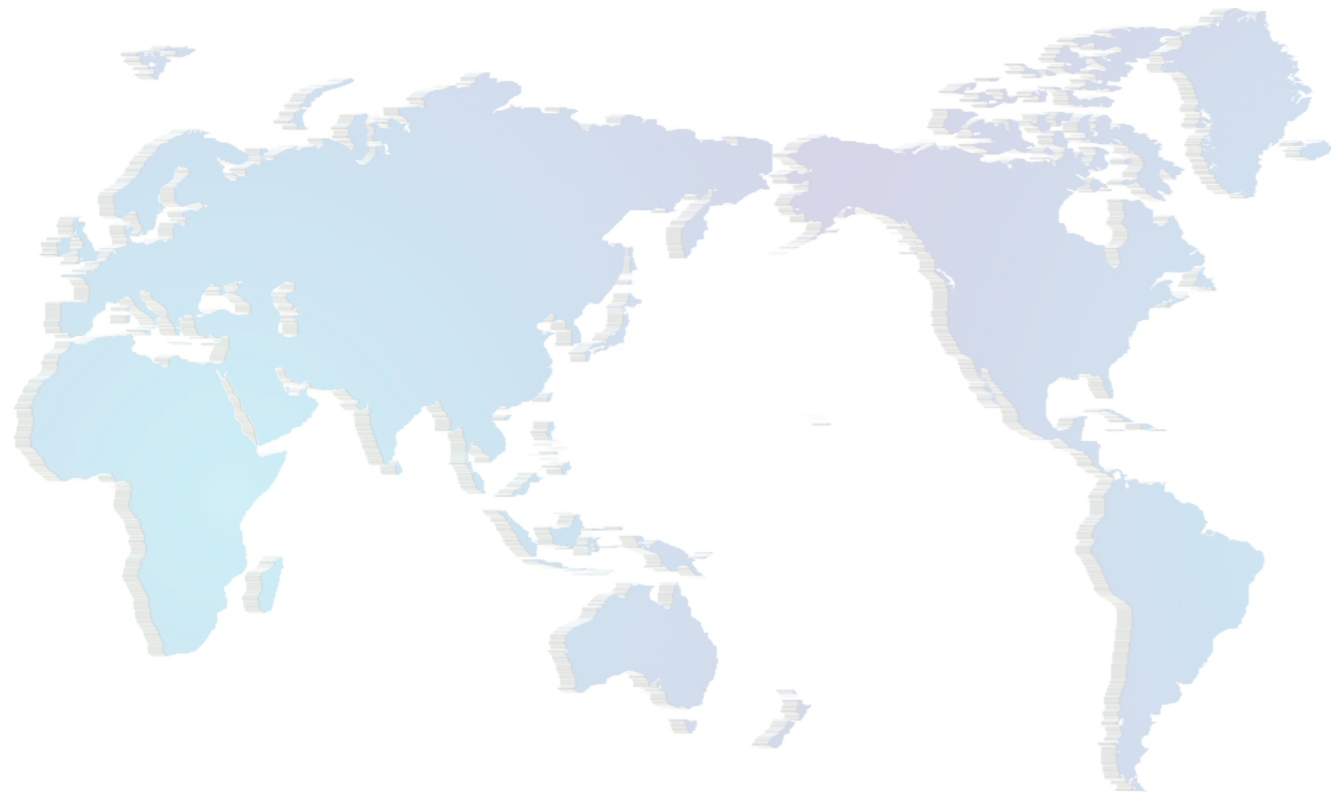

博恩

## 浙江博恩自控阀门有限公司

地址：浙江温州经济开发区滨海工业区三道四路119号

电话：+86-577-8637 8000 8683 0000

传真：+86-577-8688 7882

E-mail：Juen@theoborn.com

Http：//www.theoborn.com

邮编：325025



# THEOBORN AUTO-CONTROL

BP系列拨叉执行器

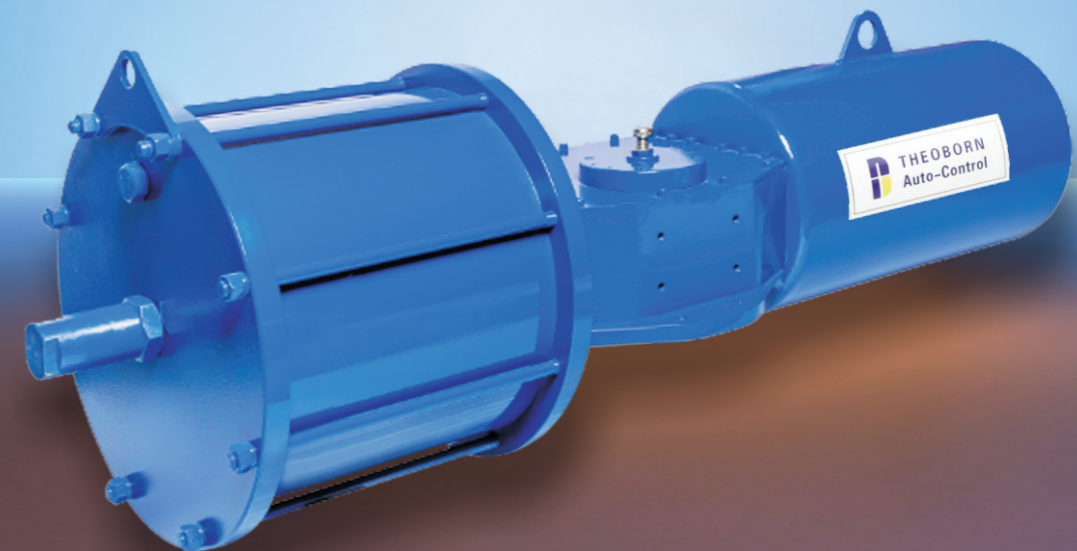

## 浙江博恩自控阀门有限公司

Zhejiang Theoborn Auto-control Valves Co.,Ltd.

[www.theoborn.com](http://www.theoborn.com)



专业品质 追求卓越



## 企业概况

浙江博恩自控阀门有限公司专业制造电动执行器、气动执行器及各类成套自控阀门。公司生产的自动化装置从根本上改变了传统上繁琐、复杂的阀门使用方法，将高科技融入阀门控制中，大大提高阀门使用效益，节省了大量的控制成本，给企业带来可观的效益。

浙江博恩自控阀门有限公司坐落在国内最具悠久泵阀制造历史的温州，公司借助当地悠久的泵阀业制造经验，结合精湛的生产工艺，加上博恩人独特的创新意识和严肃精神，努力将智慧发挥至极点，立志制造最好的产品，以之造福人类。

博恩人坚持以人为舟，以严肃为舵，以智慧为帆。博恩人相信，凭借自己的专业技术，加上真诚的服务会征服客户，赢得客户，感动客户。



## 简介

BP系列执行器采用典型的拨叉式结构设计，启闭两端实现最大的扭矩输出，可用于球阀、蝶阀、旋塞阀和各种90°旋转阀，广泛应用于化工、食品饮料、冶金、海上平台、制药、能源、造纸、纺织等行业。

### 环境温度

标准型：-20°C to +80°C  
 低温型：-40°C to +80°C  
 高温型：-20°C to +120°C

### 操作压力

气动：3~10 Bar  
 液动：50~250 Bar

## 型号编制

**BP-085S-335S-D1 HM**

**1 2 3 4 5 6 7**

### 1.产品系列

BP

### 5.温度

S：标准 -20°C~+80°C  
 L：低温 -40°C~+80°C  
 H：高温 -20°C~+120°C

### 2.中间箱体规格

065、058、100、130 160 200 270

### 6.作用型式

D1：单缸双作用  
 D2：双缸双作用  
 Sc1：单作用常闭型  
 So1：单作用常开型  
 (弹簧组合)

### 3.拨叉型式

S：对称式  
 C：倾斜式

### 7.手动模式

空白-无手动装置  
 HM：液压手动  
 DM：离合手动

### 4.气缸规格

180~1300

## 产品特性

### 1.封闭式箱体结构

中心箱体模块采用铸钢或者焊接板材质确保了足够的强度。

### 2.标准平台设计

底部与阀门连接法兰尺寸符合ISO5211标准，附件接口符合NAMUR VDI/VDE 3845标准，便于安装限位开关、定位器等附件。

### 3.耐磨设计

经过优良表面处理的活塞杆及导向杆与自润滑的轴承组合，保证优良的耐磨性，延长所有滑动零件的使用寿命

### 4.防水保护

箱体、箱盖、汽缸等连接处装有密封圈，以阻止外界的水分进入驱动装置内。

### 5.防腐蚀

BP系列气动执行器喷涂3层以上防护涂层，满足了石化、海滨等环境的要求。

### 6.自润滑性

BP系列气动执行器采用自润滑结构设计，无需再润滑，确保最大的耐磨性能和使用寿命。

### 7.模块化设计

BP系列气动执行器采用高效的和可互换的模块化设计，包括箱体、汽缸、弹簧、液压、手动等；模块化设计的部件具有可替换，可仓储等特性，满足较短的供货周期。

### 8.安全弹簧模块

为保证在安装和维护弹簧模块时操作者的安全，弹簧模块只能整体沿着汽缸模块轴线移出，避免弹簧力对人和执行器的伤害。

### 9.手动装置

可采用离合手动装置和液压手动装置。

### 10.免维护工作

BP系列气动执行器可以在免维护情况下提供长期高效的工作。

## 结构特点

### 1. 导向杆

镀硬铬合金钢导向杆对横向载荷提供良好支撑。

### 2. 滑块

铝青铜滑块及高频淬火合金钢轴销可降低接触应力、提高使用寿命。

### 3. 气缸

气缸采用镀镍抛光处理，可有效提高其耐腐蚀性和减少摩擦系数。

### 4. 导向环

采用低摩擦、长寿命复合材料，避免了金属和金属之间的直接接触，维修更换简单方便。

### 5. 弹簧

高强度合金钢弹簧提供持续稳定的扭矩输出，提高循环使用寿命。

### 6. 限位调节

双向行程限位螺钉，满足驱动装置 $90^\circ \pm 5^\circ$ 范围内可调，使阀门达到理想阀位。

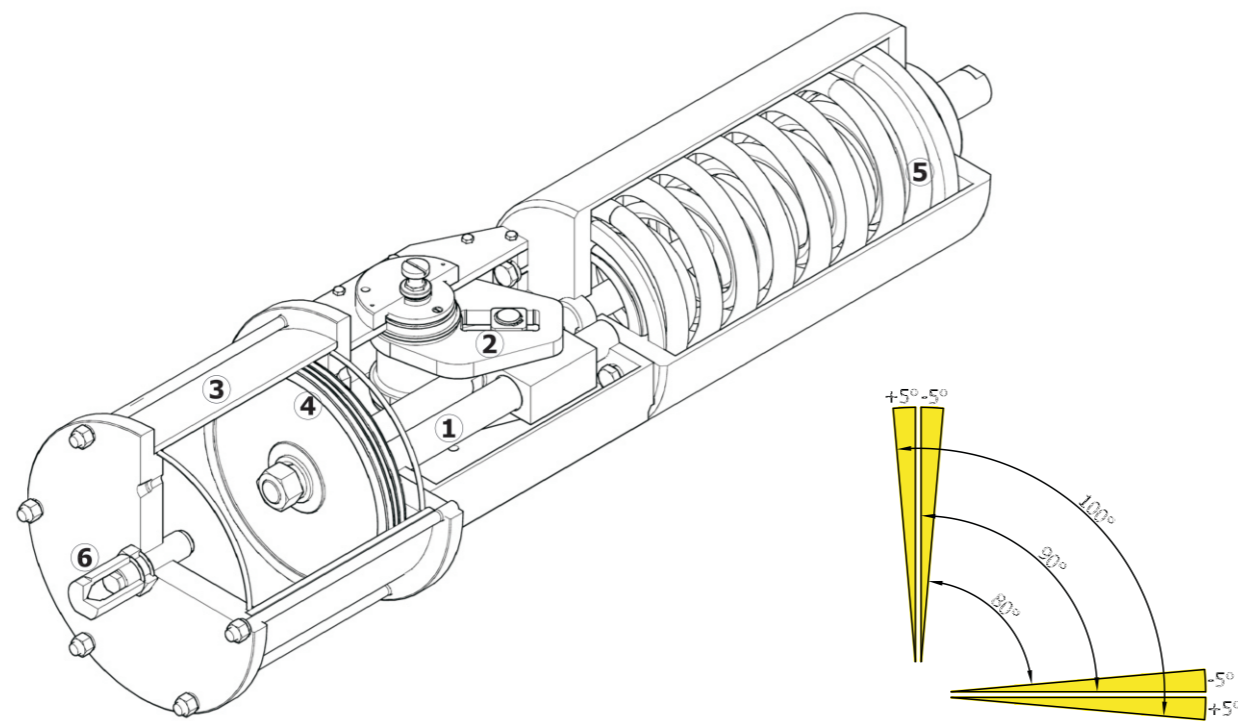

## 总装图及零部件列表

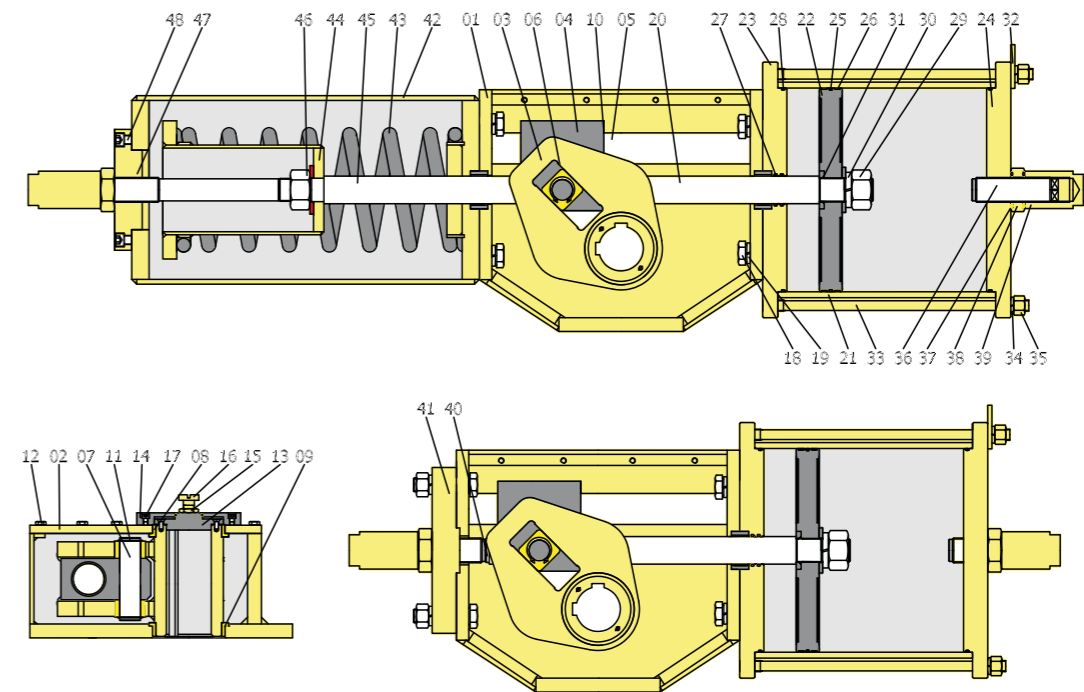

序号	名称	材质	序号	名称	材质	序号	名称	材质
1	箱体	碳钢	17	螺钉	不锈钢	33	螺柱	碳钢
2	箱盖	碳钢	18	螺栓	碳钢	34	螺母	碳钢
3	拨叉	碳钢	19	垫圈	弹簧钢	35	垫圈	弹簧钢
4	导向块	碳钢	20	活塞杆	碳钢	36	调节螺栓	碳钢
5	导向杆	合金钢	21	缸体	碳钢	37	螺母	碳钢
6	滑块	铜	22	活塞	碳钢	38	O形圈	NBR
7	轴销	合金钢	23	前端盖	碳钢	39	调节螺栓套	碳钢
8	上轴套	铜	24	后端盖	碳钢	40	柱塞	碳钢
9	下轴套	铜	25	O形圈	NBR	41	端盖法兰	碳钢
10	滑动轴承	铜+PTFE	26	导向环	PTFE	42	弹簧缸	碳钢
11	挡圈	弹簧钢	27	O形圈	NBR	43	弹簧	合金钢
12	螺栓	合金钢	28	O形圈	NBR	44	弹簧座	碳钢
13	指示盖板	碳钢	29	螺母	碳钢	45	拉杆	碳钢
14	拨叉盖板	碳钢	30	垫圈	弹簧钢	46	螺母	碳钢
15	螺母	不锈钢	31	O形圈	NBR	47	端盖压板	碳钢
16	指示螺钉	不锈钢	32	吊环	碳钢	48	螺钉	碳钢

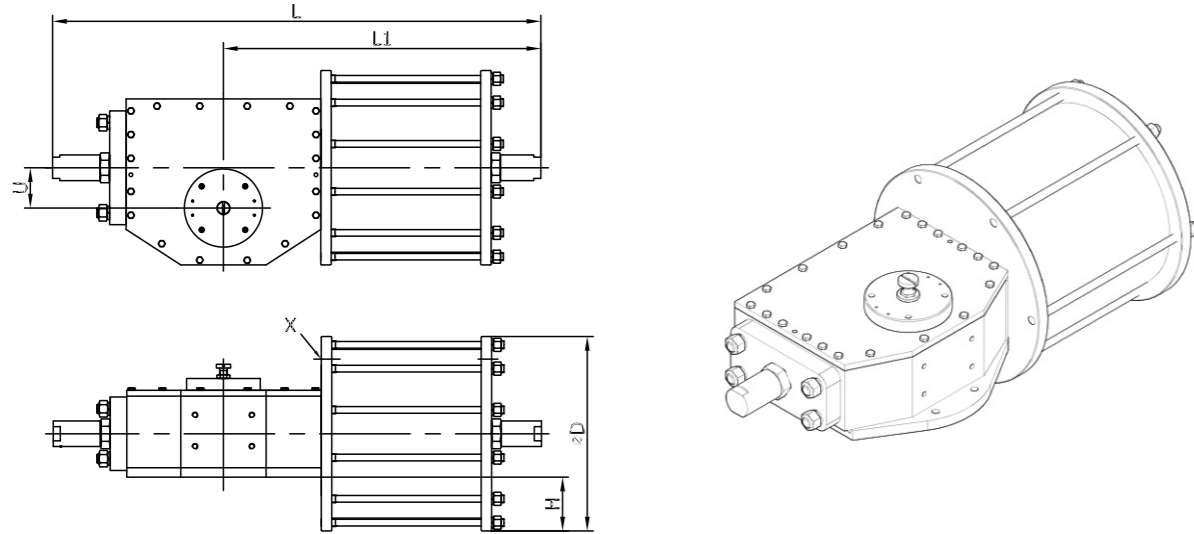
**结构尺寸表**
**双作用型**

型号	L1	L	D	U	H	X (NPT)	气腔容积	
							气开	气关
BP-065S-180*-D1	605	935	240	65	40	1/4"	5.4	4.1
BP-065S-235*-D1	605	935	310	65	75	1/2"	9.3	7.1
BP-065S-280*-D1	610	940	355	65	98	1/2"	13.2	10.2
BP-065S-335*-D1	630	960	415	65	128	1/2"	19.2	15
BP-085S-235*-D1	685	1045	310	85	70	1/2"	11.5	9.2
BP-085S-280*-D1	690	1050	355	85	93	1/2"	16.3	13.2
BP-085S-335*-D1	710	1070	415	85	123	1/2"	23.6	19.4
BP-085S-385*-D1	722	1080	465	85	148	1"	31	25.5
BP-085S-435*-D1	722	1080	515	85	173	1"	39.5	32.6
BP-100S-335*-D1	800	1210	415	100	104	1/2"	27.1	22.9
BP-100S-385*-D1	812	1220	465	100	129	1"	35.6	30.1
BP-100S-435*-D1	812	1220	515	100	154	1"	45.5	38.5
BP-100S-485*-D1	825	1235	570	100	181	1"	56.2	47.5
BP-100S-535*-D1	840	1250	620	100	206	1"	68.3	57.9
BP-130S-335*-D1	960	1460	415	130	97	1/2"	34.2	28.7
BP-130S-385*-D1	977	1475	465	130	122	1"	45.5	38.5
BP-130S-435*-D1	990	1490	515	130	147	1"	57.8	49
BP-130S-485*-D1	990	1490	570	130	174	1"	71.9	61
BP-130S-535*-D1	1005	1505	620	130	199	1"	87.4	74.4
BP-130S-585*-D1	1020	1520	680	130	229	1"	104.6	89.1
BP-130S-635*-D1	1020	1520	730	130	254	1"	123.2	105.1
BP-130S-685*-D1	1020	1520	780	130	279	1"	143.4	122.4

**双作用型**

型号	L1	L	D	U	H	X (NPT)	气腔容积	
							气开	气关
BP-160S-385*-D1	1102	1655	465	160	103	1"	54.2	47
BP-160S-435*-D1	1115	1665	515	160	128	1"	69	60
BP-160S-485*-D1	1115	1665	570	160	155	1"	85.7	74.8
BP-160S-535*-D1	1130	1680	620	160	180	1"	104.3	91.1
BP-160S-585*-D1	1145	1695	680	160	210	1"	124.7	109.1
BP-160S-635*-D1	1145	1695	730	160	235	1"	146.9	128.7
BP-160S-685*-D1	1145	1695	780	160	260	1"	171	149.9
BP-160S-735*-D1	1150	1700	840	160	285	1"	196.9	177
BP-160S-785*-D1	1150	1700	890	160	305	1"	224.6	202
BP-200S-485*-D1	1335	1995	570	200	135	1"	107	93.5
BP-200S-535*-D1	1345	2005	620	200	160	1"	129	113
BP-200S-585*-D1	1360	2020	680	200	190	1"	154.3	135.4
BP-200S-635*-D1	1375	2035	730	200	215	1"	181.8	159.8
BP-200S-685*-D1	1390	2050	780	200	240	1"	211.5	186.1
BP-200S-735*-D1	1390	2050	840	200	270	1"	243.5	214.5
BP-200S-785*-D2	1390	2050	890	200	295	1"	277.8	244.9
BP-200S-835*-D3	1390	2050	940	200	320	1"	314.3	277.3
BP-200S-885*-D4	1405	2065	990	200	345	1"	353.1	311.7
BP-200S-935*-D5	1405	2065	1040	200	370	1"	394.1	348
BP-200S-985*-D1	1405	2065	1090	200	395	1"	437.4	386.4
BP-270S-785*-D1	1700	2510	890	270	225	1"	328	293
BP-270S-835*-D1	1700	2510	940	270	270	1"	371	331
BP-270S-885*-D1	1715	2525	990	270	295	1"	417	372
BP-270S-935*-D1	1715	2525	1040	270	320	1"	466	415
BP-270S-985*-D1	1715	2525	1090	270	345	1"	517	461
BP-270S-1050*-D1	1730	2540	1165	270	385	1"	587	524
BP-270S-1100*-D1	1730	2540	1220	270	410	1"	644	575
BP-270S-1150*-D1	1730	2540	1270	270	435	1"	704	628
BP-270S-1200*-D1	1730	2540	1320	270	460	1"	767	684

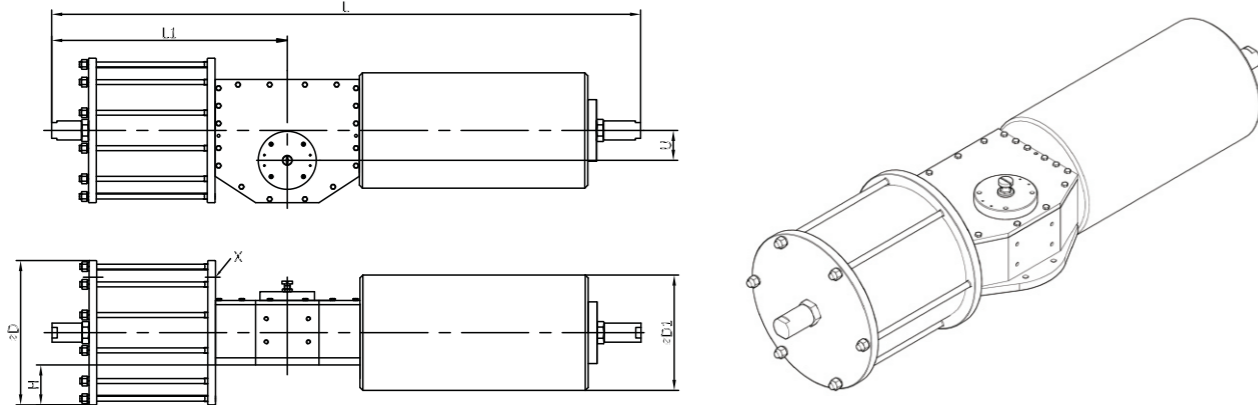
**结构尺寸表**
**单作用型**

型号	L1	L	D	D1	U	H	X (NPT)	气腔容积
BP-065S-235*-S1	605	1515	310	273	65	75	1/2"	7.1
BP-065S-280*-S1	610	1520	355	273	65	98	1/2"	10.2
BP-065S-280*-S2	610	1520	355	273	65	98	1/2"	10.2
BP-065S-335*-S2	630	1540	415	273	65	128	1/2"	15
BP-065S-280*-S3	610	1485	355	325	65	98	1/2"	10.2
BP-065S-335*-S3	630	1505	415	325	65	128	1/2"	15
BP-065S-335*-S4	630	1535	415	325	65	128	1/2"	15
BP-085S-235*-S1	685	1625	310	273	85	70	1/2"	9.2
BP-085S-280*-S1	690	1630	355	273	85	93	1/2"	13.2
BP-085S-280*-S2	690	1630	355	273	85	93	1/2"	13.2
BP-085S-335*-S2	710	1650	415	273	85	123	1/2"	19.4
BP-085S-385*-S2	722	1662	465	273	85	148	1"	25.5
BP-085S-280*-S3	690	1645	355	325	85	93	1/2"	13.2
BP-085S-335*-S3	710	1665	415	325	85	123	1/2"	19.4
BP-085S-385*-S3	722	1677	465	325	85	148	1"	25.5
BP-085S-435*-S3	722	1677	515	325	85	173	1"	32.6
BP-085S-335*-S4	709	1685	415	325	85	123	1/2"	19.4
BP-085S-385*-S4	722	1697	465	325	85	148	1"	25.5
BP-085S-435*-S4	722	1697	515	325	85	173	1"	32.6
BP-085S-335*-S5	710	1665	415	325	85	123	1/2"	19.4
BP-085S-385*-S5	722	1677	465	325	85	148	1"	25.5
BP-085S-435*-S5	722	1677	515	325	85	173	1"	32.6
BP-085S-385*-S6	722	1682	465	325	85	148	1"	25.5
BP-085S-435*-S6	722	1682	515	325	85	173	1"	32.6
BP-085S-435*-S7	722	1772	515	406	85	173	1"	32.6
BP-100S-385*-S1	812	2017	465	406	100	129	1"	22.9
BP-100S-435*-S1	812	2017	515	406	100	154	1"	30.1
BP-100S-485*-S1	825	2030	570	406	100	181	1"	38.5
BP-100S-535*-S1	840	2045	620	406	100	206	1"	47.5

**单作用型**

型号	L1	L	D	D1	U	H	X (NPT)	气腔容积
BP-100S-435*-S2	812	1957	515	406	100	154	1"	38.5
BP-100S-485*-S2	825	1970	570	406	100	181	1"	47.5
BP-100S-535*-S2	840	1985	620	406	100	206	1"	57.9
BP-130S-435*-S1	990	2365	515	457	130	147	1"	49
BP-130S-485*-S1	990	2365	570	457	130	174	1"	61
BP-130S-535*-S1	1005	2380	620	457	130	199	1"	74.4
BP-130S-585*-S1	1020	2395	680	457	130	229	1"	89.1
BP-130S-635*-S1	1020	2395	730	457	130	254	1"	105.1
BP-130S-535*-S2	1005	2390	620	508	130	199	1"	74.4
BP-130S-585*-S2	1020	2405	680	508	130	229	1"	89.1
BP-130S-635*-S2	1020	2405	730	508	130	254	1"	105.1
BP-130S-685*-S2	1020	2405	780	508	130	279	1"	122.4
BP-130S-585*-S3	1020	2425	680	508	130	229	1"	89.1
BP-130S-635*-S3	1020	2425	730	508	130	254	1"	105.1
BP-130S-685*-S3	1020	2425	780	508	130	279	1"	122.4
BP-130S-735*-S3	1035	2440	840	508	130	279	1"	140.8
BP-160S-535*-S1	1130	3250	620	560	160	180	1"	91.1
BP-160S-585*-S1	1145	3265	680	560	160	210	1"	109.1
BP-160S-635*-S1	1145	3265	730	560	160	235	1"	128.7
BP-160S-685*-S1	1145	3265	780	560	160	260	1"	149.9
BP-160S-735*-S1	1160	3280	840	560	160	285	1"	177
BP-160S-785*-S1	1160	3280	890	560	160	305	1"	202
BP-160S-585*-S2	1145	3095	680	560	160	210	1"	109.1
BP-160S-635*-S2	1145	3095	730	560	160	235	1"	128.7
BP-160S-685*-S2	1145	3095	780	560	160	260	1"	149.9
BP-160S-735*-S2	1140	3110	840	560	160	285	1"	177
BP-160S-785*-S2	1140	3110	890	560	160	305	1"	202
BP-160S-635*-S3	1145	3125	730	600	160	235	1"	128.7
BP-160S-685*-S3	1145	3125	780	600	160	260	1"	149.9
BP-160S-735*-S3	1160	3140	840	600	160	285	1"	177
BP-160S-785*-S3	1160	3140	890	600	160	305	1"	202
BP-200S-635*-S1	1375	3515	730	600	200	215	1"	159.8
BP-200S-685*-S1	1390	3530	780	600	200	240	1"	186.1
BP-200S-735*-S1	1390	3530	840	600	200	270	1"	214.5
BP-200S-785*-S1	1390	3530	890	600	200	295	1"	244.9
BP-200S-835*-S1	1390	3530	940	600	200	320	1"	277.3
BP-200S-885*-S1	1405	3545	990	600	200	345	1"	311.7
BP-200S-785*-S2	1390	3570	890	600	200	295	1"	244.9
BP-200S-835*-S2	1390	3570	940	600	200	320	1"	277.3
BP-200S-885*-S2	1405	3585	990	600	200	345	1"	311.7
BP-200S-935*-S2	1405	3585	1040	600	200	370	1"	348
BP-200S-985*-S2	1405	3585	1090	600	200	395	1"	386.4



BP-270S-785*-S1	1700	4410	890	720	270	225	1"	293
BP-270S-835*-S1	1700	4410	940	720	270	270	1"	331
BP-270S-885*-S1	1715	4425	990	720	270	295	1"	372
BP-270S-935*-S1	1715	4425	1040	720	270	320	1"	415
BP-270S-935*-S2	1715	4590	1040	720	270	320	1"	415
BP-270S-985*-S2	1715	4590	1090	720	270	345	1"	461
BP-270S-1050*-S2	1730	4605	1165	720	270	385	1"	524
BP-270S-1100*-S2	1730	4605	1220	720	270	410	1"	575
BP-270S-1150*-S2	1730	4605	1270	720	270	435	1"	628
BP-270S-1050*-S3	1730	4605	1165	720	270	385	1"	524
BP-270S-1100*-S3	1730	4605	1220	720	270	410	1"	575
BP-270S-1150*-S3	1730	4605	1270	720	270	435	1"	628
BP-270S-1200*-S3	1730	4605	1320	720	270	460	1"	684
BP-270S-1300*-S3	1730	4605	1420	720	270	510	1"	900

平台连接尺寸

阀门连接平台尺寸

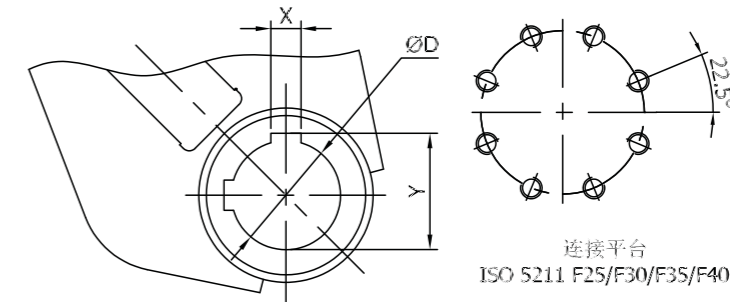
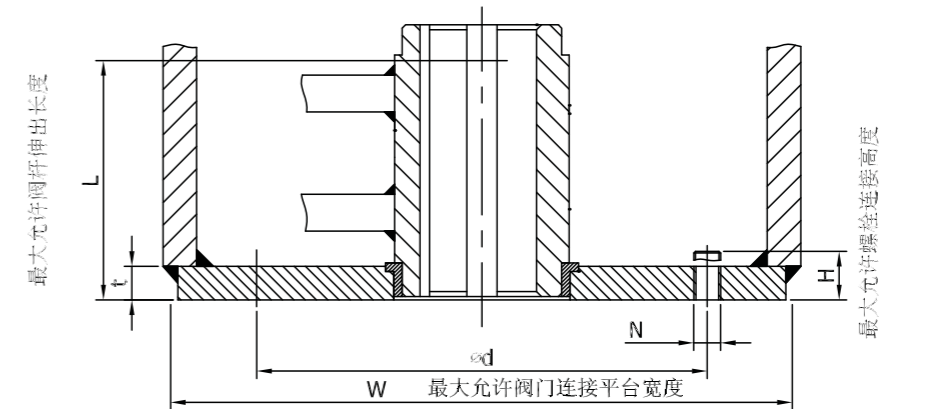

型号	ISO 5211 连接平台	D	d	N	t	H	L	W	X	Y
BP-065	F25	50 <sup>+0.2</sup> / <sub>+0.1</sub>	254	8-M16	20	24	130	320	14 <sup>+0.12</sup> / <sub>+0.05</sub>	53.8 <sup>+0.2</sup> / <sub>+0</sub>
BP-085	F25	65 <sup>+0.2</sup> / <sub>+0.1</sub>	254	8-M16	20	24	140	390	18 <sup>+0.12</sup> / <sub>+0.05</sub>	69.4 <sup>+0.2</sup> / <sub>+0</sub>
BP-100	F30	80 <sup>+0.25</sup> / <sub>+0.15</sub>	298	8-M20	25	28	170	460	22 <sup>+0.149</sup> / <sub>+0.065</sub>	85.4 <sup>+0.2</sup> / <sub>+0</sub>
BP-130	F30	110 <sup>+0.25</sup> / <sub>+0.15</sub>	298	8-M20	25	28	180	550	28 <sup>+0.149</sup> / <sub>+0.065</sub>	116.4 <sup>+0.2</sup> / <sub>+0</sub>
BP-160	F35	140 <sup>+0.30</sup> / <sub>+0.15</sub>	356	8-M30	30	35	210	660	36 <sup>+0.18</sup> / <sub>+0.08</sub>	148.4 <sup>+0.2</sup> / <sub>+0</sub>
BP-200	F40	160 <sup>+0.30</sup> / <sub>+0.15</sub>	406	8-M36	35	40	240	800	40 <sup>+0.18</sup> / <sub>+0.08</sub>	169.4 <sup>+0.2</sup> / <sub>+0</sub>
BP-270	F48	200 <sup>+0.30</sup> / <sub>+0.15</sub>	483	12-M36	45	50	300	1000	50 <sup>+0.18</sup> / <sub>+0.08</sub>	211.4 <sup>+0.3</sup> / <sub>+0</sub>

附件连接平台尺寸

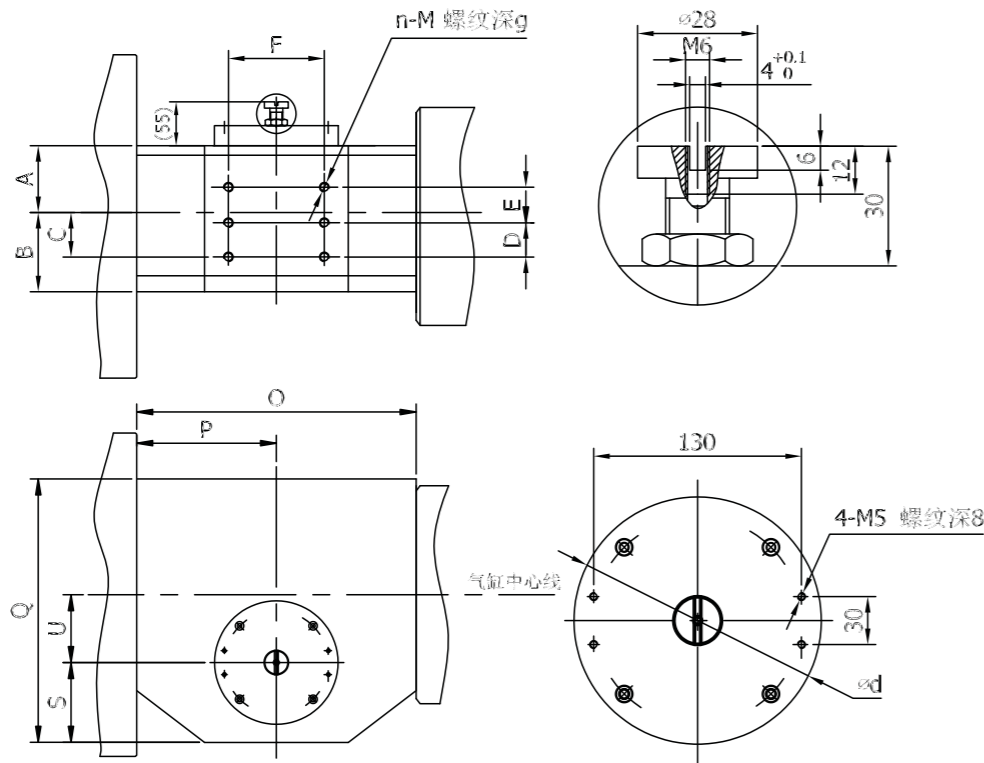

型号	A	B	C	D	E	F	n	M	g	O	P	Q	U	S	d
BP-065	75	80	27	60	-	120	4	M12	12	350	175	297	65	80	155
BP-085	78	85	30	60	-	120	4	M12	12	410	205	330	85	100	155
BP-100	92	104	50	60	35	120	6	M12	16	490	245	385	110	120	175
BP-130	102	111	50	60	35	120	6	M12	16	590	295	500	130	180	215
BP-160	115	130	60	60	60	120	6	M12	18	690	345	590	160	210	255
BP-200	135	150	70	60	60	120	6	M12	18	830	415	710	200	250	285
BP-270	180	200	100	60	60	120	6	M12	18	1050	525	890	270	290	330

输出扭矩

双作用型

型号	输出扭矩											
	4 Bar			5 Bar			6 Bar			8 Bar		
	0°	45°	90°	0°	45°	90°	0°	45°	90°	0°	45°	90°
BP-065S-180*-D1	818	508	887	1,024	637	1,111	1,230	765	1,335	1,643	1,021	1,783
BP-065S-235*-D1	1,427	887	1,548	1,786	1,111	1,938	2,145	1,334	2,328	2,863	1,780	3,107
BP-065S-280*-D1	2,046	1,272	2,220	2,560	1,592	2,778	3,075	1,912	3,336			
BP-065S-335*-D1	2,950	1,834	3,201	3,691	2,295	4,005						
BP-085S-235*-D1	1,909	1,187	2,072	2,390	1,486	2,594	2,870	1,785	3,115	3,831	2,382	4,158
BP-085S-280*-D1	2,737	1,702	2,971	3,426	2,130	3,718	4,114	2,558	4,465	5,490	3,413	5,958
BP-085S-335*-D1	3,947	2,454	4,283	4,938	3,070	5,359	5,929	3,686	6,435	7,912	4,919	8,586
BP-085S-385*-D1	5,234	3,254	5,681	6,548	4,071	7,107	7,862	4,888	8,532			
BP-085S-435*-D1	6,701	4,166	7,273	8,382	5,212	9,097						
BP-100S-335*-D1	4,688	2,914	5,090	5,866	3,646	6,369	7,043	4,378	7,647	9,398	5,842	10,204
BP-100S-385*-D1	6,218	3,865	6,751	7,778	4,835	8,445	9,339	5,806	10,140	12,460	7,746	13,529
BP-100S-435*-D1	7,960	4,948	8,643	9,957	6,190	10,811	11,954	7,431	12,979			
BP-100S-485*-D1	9,915	6,164	10,765	12,401	7,710	13,465						
BP-100S-535*-D1	12,083	7,512	13,119									
BP-130S-335*-D1	6,120	3,804	6,649	7,657	4,759	8,319	9,194	5,715	9,989	12,268	7,626	13,329
BP-130S-385*-D1	8,133	5,055	8,836	10,174	6,324	11,054	12,216	7,593	13,272	16,298	10,131	17,707
BP-130S-435*-D1	10,426	6,481	11,327	13,042	8,107	14,169	15,657	9,732	17,011	20,889	12,984	22,694
BP-130S-485*-D1	12,999	8,080	14,123	16,259	10,107	17,665	19,519	12,133	21,207	26,040	16,186	28,290
BP-130S-535*-D1	15,853	9,854	17,223	19,827	12,324	21,541	23,802	14,795	25,859	31,751	19,736	34,495
BP-130S-585*-D1	18,986	11,802	20,628	23,745	14,760	25,798	28,504	17,718	30,968			
BP-130S-635*-D1	22,400	13,924	24,337	28,014	17,413	30,435	33,627	20,902	36,534			
BP-130S-685*-D1	26,094	16,220	28,350	32,632	20,284	35,453						
BP-160S-385*-D1	10,077	6,262	10,955	12,606	7,834	13,704	15,135	9,406	16,454	20,193	12,550	21,953
BP-160S-435*-D1	12,918	8,028	14,043	16,159	10,042	17,567	19,399	12,056	21,090	25,881	16,085	28,136
BP-160S-485*-D1	16,106	10,010	17,509	20,145	12,520	21,901	24,184	15,030	26,292	32,263	20,051	35,074
BP-160S-535*-D1	19,642	12,207	21,353	24,566	15,267	26,706	29,490	18,328	32,060	39,339	24,448	42,766
BP-160S-585*-D1	23,524	14,620	25,574	29,420	18,284	31,984	35,317	21,949	38,394	47,109	29,278	51,214
BP-160S-635*-D1	27,754	17,248	30,172	34,709	21,571	37,733	41,664	25,893	45,294			
BP-160S-685*-D1	32,330	20,093	35,147	40,431	25,127	43,954	48,531	30,161	52,760			
BP-160S-735*-D1	37,254	23,153	40,500	46,587	28,953	50,646						
BP-160S-785*-D1	42,525	26,429	46,230									





双作用型

型号	输出扭矩											
	4 Bar			5 Bar			6 Bar			8 Bar		
	0°	45°	90°	0°	45°	90°	0°	45°	90°	0°	45°	90°
BP-200S-485*-D1	20,349	12,653	22,077	25,453	15,827	27,614	30,556	19,000	33,150	40,763	25,346	44,224
BP-200S-535*-D1	24,837	15,444	26,946	31,064	19,316	33,702	37,292	23,188	40,458	49,746	30,932	53,969
BP-200S-585*-D1	29,766	18,509	32,293	37,227	23,148	40,388	44,688	27,787	48,482	59,610	37,065	64,671
BP-200S-635*-D1	35,136	21,847	38,119	43,941	27,322	47,671	52,745	32,797	57,224	70,355	43,747	76,329
BP-200S-685*-D1	40,946	25,460	44,422	51,205	31,839	55,552	61,464	38,218	66,682	81,982	50,977	88,942
BP-200S-735*-D1	47,196	29,347	51,204	59,020	36,699	64,031	70,843	44,050	76,858	94,490	58,754	102,513
BP-200S-785*-D1	53,888	33,508	58,463	67,386	41,901	73,107	80,884	50,294	87,751	107,879	67,080	117,039
BP-200S-835*-D1	61,020	37,942	66,201	76,302	47,445	82,781	91,585	56,948	99,361			
BP-200S-885*-D1	68,593	42,651	74,416	85,770	53,332	93,052						
BP-200S-935*-D1	76,606	47,634	83,110	95,788	59,561	103,921						
BP-200S-985*-D1	85,060	52,890	92,282									
BP-270S-785*-D1	73,763	45,898	79,805	92,239	57,394	99,795	110,716	68,891	119,784	147,669	91,884	159,764
BP-270S-835*-D1	83,570	52,000	90,416	104,501	65,024	113,061	125,432	78,047	135,706	167,293	104,095	180,995
BP-270S-885*-D1	93,984	58,480	101,682	117,520	73,125	127,146	141,056	87,769	152,610	188,129	117,059	203,538
BP-270S-935*-D1	105,003	65,336	113,604	131,297	81,697	142,051	157,590	98,057	170,498			
BP-270S-985*-D1	116,629	72,570	126,181	145,830	90,740	157,775	175,032	108,910	189,369			
BP-270S-1050*-D1	132,647	82,537	143,512	165,857	103,201	179,422	199,067	123,865	215,372			
BP-270S-1100*-D1	145,666	90,638	157,598	182,133	113,329	197,051						
BP-270S-1200*-D1	173,522	107,971	187,735									

扭矩特性图

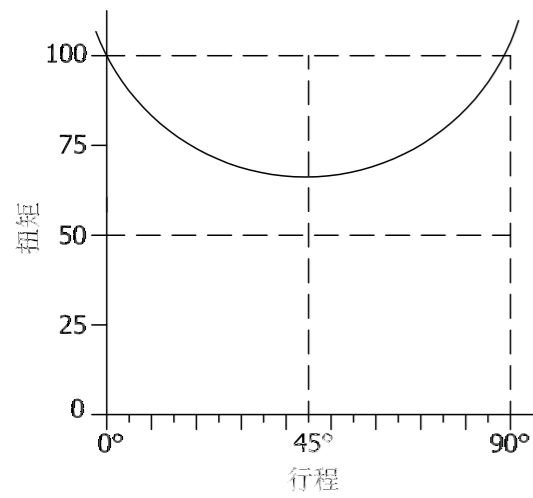

双作用扭矩曲线

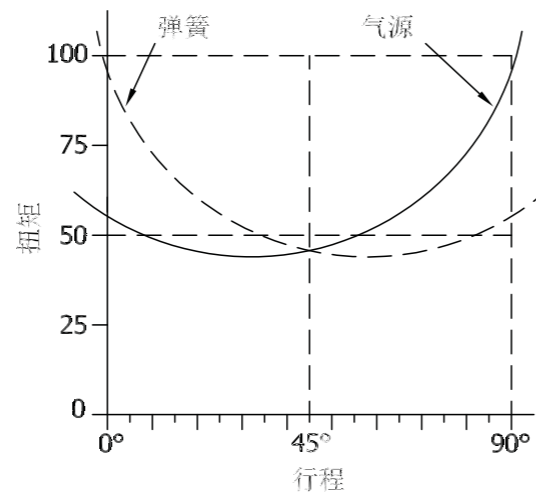

单作用扭矩曲线

输出扭矩

单作用型

型号	输出扭矩															
	Spring			3 Bar			4 Bar			5 Bar			6 Bar			
	0°	45°	90°	90°	45°	0°	90°	45°	0°	90°	45°	0°	90°	45°	0°	
BP-065S-235*-S1	948	485	664				741	345	400	1,100	568	790	1,459	792	1,180	
BP-065S-280*-S1	946	484	662	845	410	514	1,360	730	1,072							
BP-065S-280*-S2	1,582	810	1,109							1,418	689	867	1,932	1,009	1,425	
BP-065S-335*-S2	1,580	808	1,107	1,067	471	486	1,808	932	1,290	2,548	1,392	2,094				
BP-065S-280*-S3	1,968	1,033	1,470										1,564	762	963	
BP-065S-335*-S3	1,966	1,032	1,468				1,440	685	827	2,180	1,145	1,631	2,921	1,606	2,435	
BP-065S-335*-S4	2,833	1,467	2,045										2,334	1,125	1,395	
BP-085S-235*-S1	1,407	692	888							1,471	713	891	1,952	1,011	1,413	
BP-085S-280*-S1	1,404	690	885	1,131	501	522	1,819	929	1,269							
BP-085S-280*-S2	2,347	1,155	1,484										2,585	1,271	1,631	
BP-085S-335*-S2	2,344	1,153	1,481				2,419	1,167	1,450	3,410	1,783	2,526	4,401	2,400	3,601	
BP-085S-385*-S2	2,342	1,151	1,478	2,392	1,151	1,421	3,706	1,968	2,847							
BP-085S-280*-S3	2,570	1,265	1,626										2,441	1,150	1,364	
BP-085S-335*-S3	2,567	1,263	1,623				2,274	1,046	1,183	3,266	1,662	2,259	4,257	2,278	3,334	
BP-085S-385*-S3	2,564	1,261	1,620	2,248	1,030	1,154	3,562	1,846	2,580							
BP-085S-435*-S3	2,561	1,259	1,617	3,348	1,713	2,348										
BP-085S-335*-S4	3,791	1,841	2,312										3,555	1,640	1,866	
BP-085S-385*-S4	3,788	1,839	2,309							4,173	2,024	2,538	5,487	2,841	3,964	
BP-085S-435*-S4	3,785	1,837	2,306				4,326	2,120	2,704	6,008	3,165	4,528				
BP-085S-335*-S5	3,986	1,962	2,524										3,339	1,505	1,632	
BP-085S-385*-S5	3,983	1,961	2,521							3,958	1,890	2,304	5,271	2,707	3,729	
BP-085S-435*-S5	3,981	1,959	2,518				4,111	1,985	2,470	5,792	3,031	4,294	7,473	4,076	6,119	
BP-085S-385*-S6	4,926	2,425	3,120										4,661	2,193	2,598	
BP-085S-435*-S6	4,924	2,424	3,117							5,182	2,517	3,163	6,863	3,562	4,988	
BP-085S-435*-S7	6,315	3,165	4,196										5,765	2,743	3,319	
BP-100S-385*-S1	6,306	2,857	3,132										6,124	2,631	2,542	
BP-100S-435*-S1	6,303	2,855	3,128										6,742	3,015	3,213	
BP-100S-485*-S1	6,300	2,853	3,125				6,700	2,990	3,168	9,186	4,535	5,868				
BP-100S-535*-S1	6,297	2,851	3,121	5,839	2,454	2,233	8,868	4,337	5,522							
BP-100S-435*-S2	7,330	3,493	4,243										7,604	3,552	4,150	
BP-100S-485*-S2	7,326	3,491	4,239							8,052	3,830	4,636	10,538	5,376	7,336	
BP-100S-535*-S2	7,323	3,489	4,236				7,733	3,632	4,290	10,763	5,515	7,579				
BP-130S-435*-S1	9,462	4,789	6,461										9,044	4,414	5,605	
BP-130S-485*-S1	9,458	4,786	6,456							9,646	4,788	6,259	12,906	6,815	9,801	
BP-130S-535*-S1	9,454	4,784	6,452				9,240	4,536	5,817	13,214	7,006	10,135	17,189	9,477	14,453	
BP-130S-585*-S1	9,450	4,781	6,447	7,615	3,525	4,051	12,373	6,484	9,222	17,132	9,442	14,392				
BP-130S-635*-S1	9,445	4,778	6,442	10,174	5,116	6,832	15,787	8,605	12,930							



## 单作用型

型号	输出扭矩														
	Spring			3 Bar			4 Bar			5 Bar			6 Bar		
	0°	45°	90°	90°	45°	0°	90°	45°	0°	90°	45°	0°	90°	45°	0°
BP-130S-535*-S2	12,429	6,291	8,488							11,143	5,340	6,562	15,117	7,811	10,880
BP-130S-585*-S2	12,425	6,288	8,483				10,302	4,817	5,648	15,061	7,776	10,819			
BP-130S-635*-S2	12,421	6,286	8,479				13,716	6,939	9,357	19,329	10,429	15,456			
BP-130S-685*-S2	12,417	6,283	8,474	10,872	5,172	6,267	17,410	9,236	13,370						
BP-130S-585*-S3	16,402	8,093	10,472										17,796	8,739	11,214
BP-130S-635*-S3	16,397	8,091	10,468							17,305	8,434	10,681			
BP-130S-685*-S3	16,393	8,088	10,463				15,386	7,241	8,596	21,924	11,305	15,699			
BP-130S-735*-S3	16,389	8,085	10,459	11,828	5,029	4,730	19,360	9,711	12,913						
BP-160S-535*-S1	16,275	8,880	13,372										15,834	8,475	12,437
BP-160S-585*-S1	16,270	8,876	13,366							15,764	8,432	12,361	21,660	12,096	18,771
BP-160S-635*-S1	16,265	8,873	13,360				14,097	7,396	10,549	21,052	11,718	18,110			
BP-160S-685*-S1	16,260	8,870	13,355				18,674	10,240	15,524	26,774	15,275	24,331			
BP-160S-735*-S1	16,255	8,867	13,349	14,265	7,500	10,731	23,598	13,300	20,877						
BP-160S-785*-S1	16,249	8,863	13,344	18,217	9,956	15,028									
BP-160S-585*-S2	18,940	10,209	15,127										19,870	10,623	15,563
BP-160S-635*-S2	18,935	10,206	15,121							19,262	10,245	14,902	26,217	14,567	22,463
BP-160S-685*-S2	18,929	10,203	15,116				16,884	8,767	12,317	24,984	13,801	21,123			
BP-160S-735*-S2	18,924	10,200	15,110				21,808	11,827	17,670	31,140	17,627	27,816			
BP-160S-785*-S2	18,919	10,196	15,104	16,427	8,483	11,820	27,078	15,103	23,400						
BP-160S-635*-S3	23,942	12,890	19,068										22,204	11,601	16,447
BP-160S-685*-S3	23,937	12,887	19,062							20,972	10,835	15,106	29,072	15,869	23,913
BP-160S-735*-S3	23,931	12,884	19,057				17,795	8,861	11,653	27,128	14,661	21,799			
BP-160S-785*-S3	23,926	12,880	19,051				23,066	12,136	17,383	33,718	18,756	28,963			
BP-200S-635*-S1	31,409	16,372	23,055										29,165	14,644	19,460
BP-200S-685*-S1	31,403	16,368	23,047							27,625	13,686	17,788	37,884	20,065	28,918
BP-200S-735*-S1	31,396	16,364	23,040				23,616	11,194	13,440	35,440	18,546	26,267			
BP-200S-785*-S1	31,390	16,360	23,033				30,308	15,355	20,699	43,806	23,748	35,343			
BP-200S-835*-S1	31,383	16,356	23,026	22,157	10,287	11,857	37,440	19,789	28,437						
BP-200S-885*-S1	31,376	16,351	23,019	27,835	13,817	18,017	45,013	24,498	36,652						
BP-200S-785*-S2	45,558	22,967	30,719										49,474	24,838	32,998
BP-200S-835*-S2	45,551	22,963	30,712							44,893	21,989	28,027	60,175	31,492	44,608
BP-200S-885*-S2	45,545	22,959	30,704				37,183	17,195	19,663	54,360	27,876	38,299			
BP-200S-935*-S2	45,538	22,955	30,697				45,196	22,178	28,357	64,378	34,105	49,168			
BP-200S-985*-S2	45,532	22,951	30,690	32,353	14,192	14,423	53,650	27,434	37,528						

## 单作用型

型号	输出扭矩																	
	Spring			3 Bar			4 Bar			5 Bar			6 Bar					
	0°	45°	90°	90°	45°	0°	90°	45°	0°	90°	45°	0°	90°	45°	0°			
BP-270S-785*-S1	63,158	30,925	39,212												70,500	34,612	44,090	
BP-270S-835*-S1	63,149	30,919	39,202										64,285	30,745	37,366	85,216	43,769	60,011
BP-270S-885*-S1	63,140	30,914	39,192							53,768	24,201	25,988	77,304	38,846	51,452			
BP-270S-935*-S1	63,131	30,908	39,182							64,788	31,058	37,910						
BP-270S-935*-S2	85,791	41,446	51,313										78,688	35,771	39,259	104,982	52,131	67,706
BP-270S-985*-S2	85,782	41,441	51,303										93,222	44,814	54,984	122,424	62,984	86,578
BP-270S-1050*-S2	85,770	41,433	51,290							80,039	36,611		113,249	57,275	76,651			
BP-270S-1100*-S2	85,761	41,428	51,280							93,058	44,712							
BP-270S-1150*-S2	85,752	41,422	51,271	66,808	28,378	26,406	106,683	53,190										
BP-270S-1050*-S3	121,590	57,225	67,452										96,738	39,821	33,817	129,948	60,485	69,747
BP-270S-1100*-S3	121,581	57,219	67,442										113,014	49,949	51,426	149,481	72,639	90,880
BP-270S-1150*-S3	121,572	57,214	67,432										130,048	60,547	69,855			
BP-270S-1200*-S3	121,563	57,208	67,422							104,404	44,591		147,839	71,617	89,103			
BP-270S-1300*-S3	121,545	57,197	67,403							134,683	63,432							