

Consider People As a Boat,
Consider Seriousness As Her Helm,
And Consider Wisdom As Her Sail.



THEOBORN

Zhejiang Theoborn Auto-control Valves Co.,Ltd

ADD : No.119 , 4th Road , 3rd Avenue , Binhai Industrial Zone ,
Economic & Technical , Wenzhou , China.

TEL : +86-577-8637 8000 8683 0000

FAX : +86-577-8688 7882

E-mail : Juen@theoborn.com

Http : //www.theoborn.com

P.C : 325025



THEOBORN

THEOBORN AUTO-CONTROL

TBNS Series Stainless Steel Pneumatic Actuator



Zhejiang Theoborn Auto-control Valves Co.,Ltd.

www.theoborn.com



Company Profile

Zhejiang Theoborn Auto-Control Valves Co., Ltd. is dedicated to manufacture pneumatic actuators , electric actuators. Our products fundamentally transform the complex traditional usage of valves , incorporating high technology with the control process of valves , greatly improving the efficient usage of valves , largely diminishing the controlling cost , and obtaining considerable profits for enterprises.

Theoborn company is located in wenzhou city which possesses a long history of manufacturing valves and pumps. Inspired by our experience of manufacturing valves and pumps, supported by exquisite manufacturing technique , and enveloped with the special innovative consciousness and serious spirit. Theoborn endeavors to culminate the wisdom , aspires to make the best products , and desires to benefit human beings.



Theoborn people believe that we should consider people as boat , consider wisdom as helm and consider seriousness as sail Theoborn believes that professional technology , along with the sincere service, will obtain customers' hearts , win customers'credits , and move customers.

Product Introduction

TBNS Series stainless steel pneumatic actuator is powered by compressed air, through the linear motion of the piston rack drives the gear output shaft, to angle stroke output pneumatic actuators. A double action and single action type, widely applicable to ball valve, butterfly valve switch, plug valve isometric stroke of the valve and adjusting, can also be used in other rotary occasions, is to realize the ideal device for industrial pipeline automation control.



Features of the TBNS Series stainless steel pneumatic actuator

- ◆ ASTM316L、 316、 304 stainless steel pneumatic actuator with electro-polish finish offer excellent resistance to most corrosive chemicals as well as industrial atmospheres.
- ◆ Dual piston rack and pinion design for compact construction, symmetric mounting position, high-cycle life and fast operation, reverse rotation can be accomplished in the field by simply inverting the pistons.
- ◆ Multiple bearings and guides on racks and pistons, low friction, high cycle life and prevent shaft blowout.
- ◆ Modular preloaded spring cartridge design, with coated spring for simple versatile range, greater safety and corrosion resistance, longer cycle life.
- ◆ Fully machined teeth on piston and pinion for accurate low backlash rack and pinion engagement, maximum efficiency.
- ◆ The two independent external travel stop adjustment bolts can adjust $\pm 5^\circ$ at both open and close directions easily and precisely.
- ◆ Stainless steel fasteners for long term corrosion resistance.
- ◆ Full conformance to the latest specifications:ISO5211,DIN3337 and Namur or product interchangeability and easy mounting of solenoids, limit switches and other accessories.

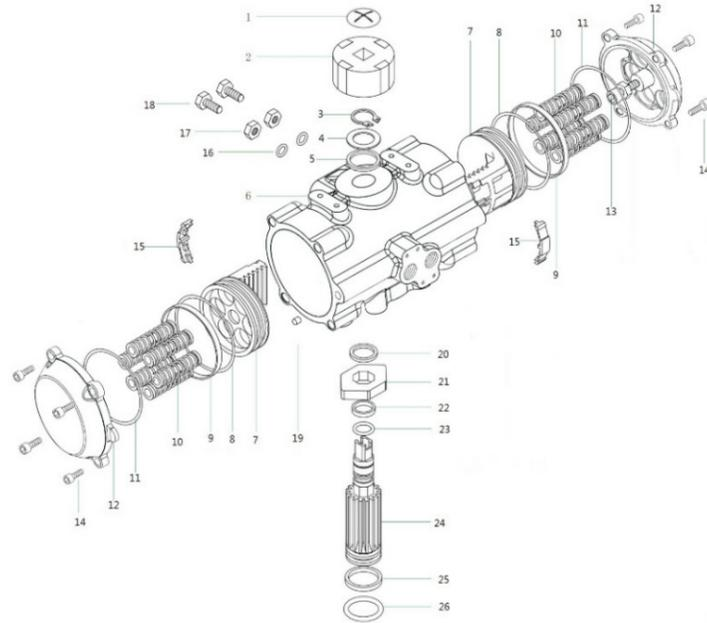

Operating Principle and Out Torque

Operating Principle

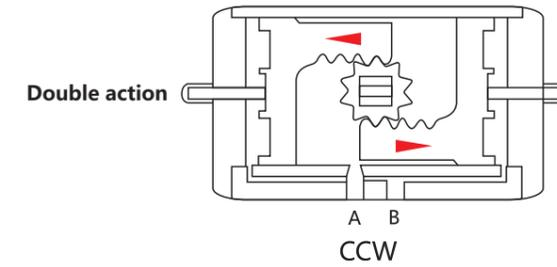

Air to Port A forces the pistons outwards, causing the pinion to turn counterclockwise while the air is being exhausted from Port B.

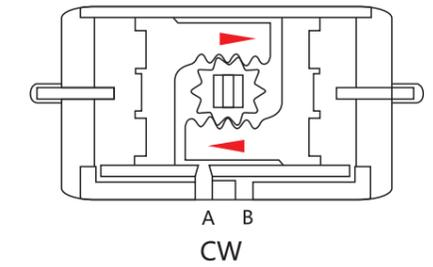

Air to Port B forces the pistons inwards, causing the pinion to turn clockwise while the air is being exhausted from Port A.

Parts and Materials

NO	Description	Qty	Standards Material
1	Indicator Screw	1	Plastic
2	Indicator	1	Plastic
3	Snap Ring	1	Stainless steel
4	Washer	1	Stainless steel
5	Outside Washer	1	Engineering Plastics
6	Body	1	Stainless steel
7	Piston	2	Stainless steel
8	Piston O-ring	2	Viton/NBR
9	Piston Bearing	2	Engineering Plastics
10	Spring Spring Retainer(L,R) Retainer Connector	0-12	Spring Steel 66 Nylon 66 Brass
11	End-Cap O-ring	2	Viton/NBR
12	End-Cap	2	Stainless steel
13	Stop screw	2	Stainless steel
14	End-Cap Stop Screw	8	Stainless steel
15	Guide Piston	2	Nylon 66
16	O-ring(Adjust screw)	2	NBR
17	Nut(Adjust screw)	2	Stainless steel
18	Adjust screw	2	Stainless steel
19	Plug	2	NBR
20	Inside Washer	1	Engineering Plastics
21	Cam	1	Stainless steel
22	Bearing Top	1	Engineering Plastics
23	O-ring(Top)	1	Viton/NBR
24	Pinion	1	Stainless steel
25	Bearing Bottom	1	Engineering Plastics
26	O-ring Bottom	1	Viton/NBR

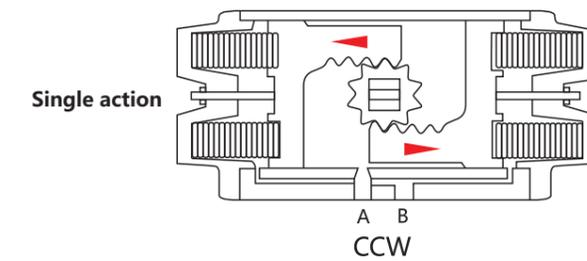

Air to Port A forces the pistons outwards, causing the springs to compress. The pinion turns counterclockwise while air is being exhausted from Port B.

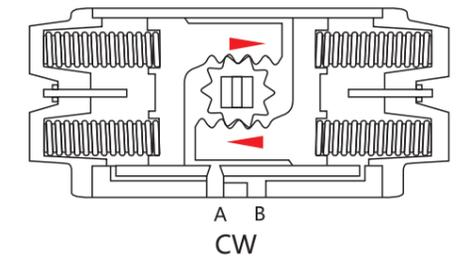

Loss of air pressure, the stored energy in the springs forces the pistons inwards, the pinion turns clockwise while air is being exhausted from Port A.

Output Torque With Double Acting

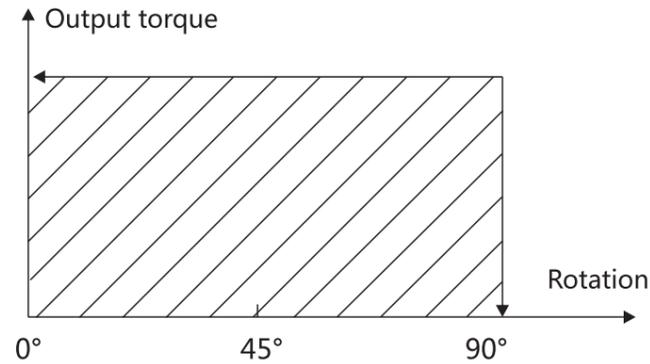

Output Torque Table of SK Series Pneumatic Actuators with Double Acting

Model	Air Pressure					
	3bar	4bar	5bar	6bar	7bar	8bar
TBNS-052DA	11.6	15.4	19.2	23.0	26.8	30.6
TBNS-063DA	20.9	28.1	35.3	42.4	49.6	56.8
TBNS-075DA	28.8	38.8	49.0	58.8	68.6	78.4
TBNS-083DA	44.0	58.7	73.5	88.2	102.9	117.6
TBNS-092DA	66.2	88.3	110.3	132.5	154.5	176.6
TBNS-105DA	95.6	127.2	158.8	190.4	222.0	253.6
TBNS-125DA	145.3	193.9	242.5	291.1	339.6	388.2
TBNS-140DA	250	337	425	511	596	681
TBNS-160DA	381	514	649	779	908	1038
TBNS-190DA	615	828	1046	1255	1464	1673
TBNS-210DA	782	1043	1303	1564	1825	2085
TBNS-240DA	1131	1508	1885	2262	2639	3016
TBNS-270DA	1720	2293	2866	3440	4013	4586
TBNS-300DA	2291.4	3055.2	3819.0	4582.8	5346.6	6110.4
TBNS-350DA	3426.0	4568.0	5710.0	6852.0	7994.0	9136.0
TBNS-400DA	4872.0	6496.0	8120.0	9744.0	11368.0	12992.0

Sizing: Spring Return Actuators

The suggested safety factor for double acting actuators under normal working conditions is 20%-30%.

Example:

The torque needed by valve=100N.m

The torque considered safety factor

(1+30%)=130N.m Air Supply=5Bar

According to the above table, we can choose the minimum model is TBNS-105DA.

Output Torque with Spring Return

Output Torque of Pneumatic Actuator with Spring Return

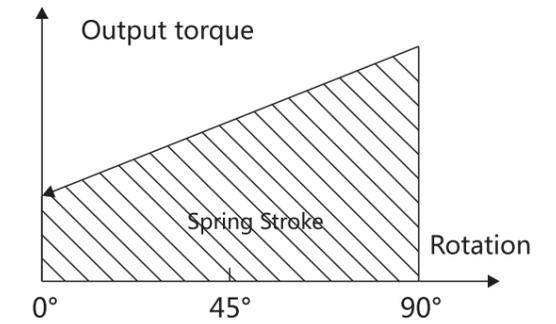
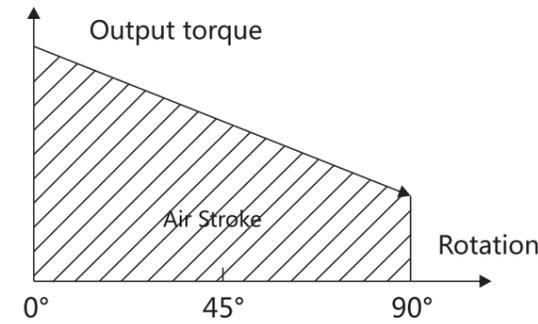

Model	Spring Qty.	Output Torque of Spring		Output Torque of Air Supply											
		0°	90°	3bar		4bar		5bar		6bar		7bar			
				0°	90°	0°	90°	0°	90°	0°	90°	0°	90°		
TBNS-052SK	5	3.6	5.4	6.5	4.6	10.8	8.6								
	6	4.3	6.7	6	3.3	10.2	7.3								
	7	5.1	7.9			9.6	6.1	13.7	10.1						
	8	5.8	9.2			9	4.8	13	8.8						
	9	6.6	10.4			8.4	3.6	12.4	7.6	16.4	11.6				
	10	7.3	11.7			7.8	2.3	11.8	6.3	15.7	10.3	19.6	14.3		
	11	8.1	12.9					11.1	5.1	15	9.1	18.8	13.1		
12	8.8	14.2					10.5	3.8	14.3	7.8	18	11.8			
TBNS-063SK	5	6.1	12	16.3	10.6	23.2	17.7								
	6	7.3	13.7	14.5	7.9	21.4	15								
	7	8.6	15.5			19.7	12.4	26.6	19.5						
	8	9.8	17.2			17.9	9.8	25	17						
	9	11.1	19			16.2	7.2	23.3	14.4	30.4	21.7				
	10	12.3	20.7			14.4	4.5	21.6	11.9	28.8	19.2	35.9	26.5		
	11	13.6	22.5					19.9	9.3	27.1	16.7	34.4	24.1		
12	14.8	24.2					18.2	6.7	25.5	14.2	32.8	21.7			
TBNS-075SK	5	9.5	14.3	18.8	14.1	28.2	23.5								
	6	11.4	17.1	16.9	11.3	26.3	20.7								
	7	13.3	20	15	8.5	24.4	17.9								
	8	15.2	22.8			22.6	15	32	24.4						
	9	17.1	25.7			20.7	12.2	30.1	21.6	39.5	31				
	10	19	28.5			18.8	9.4	28.2	18.8	37.6	28.2	47	37.6		
	11	20.9	31.4			16.9	6.6	26.3	16	35.7	25.4	45.1	34.8		
12	22.8	34.2					24.4	13.2	33.8	22.6	43.2	32			
TBNS-083SK	5	15	20.4	30.2	22.8	45.3	39.2								
	6	18	24.6	26.9	17.6	41.9	33.9								
	7	21	28.7			38.5	28.6	53.4	44.8						
	8	24	32.9			35.1	23.2	49.9	39.3						
	9	27	37.1			31.6	17.9	46.5	33.8	61.3	49.8				
	10	30	41.2			28.2	12.6	43	28.4	57.7	44.2	72.5	60.1		
	11	33	45.4					39.5	22.9	54.2	38.6	68.9	54.3		
12	36	49.6					36	17.5	50.6	33.1	65.3	48.6			
TBNS-092SK	5	22.1	32.3	41	32.6	62.4	53.8								
	6	26.5	38.7	36.8	26.4	58.1	47.6								
	7	30.9	45.2			53.8	41.4	74.8	62.5						
	8	35.3	51.6			49.6	35.2	70.5	56.3						
	9	39.7	58.1			45.3	29	66.2	50.1	87.2	71.3				
	10	44.2	64.6			41	22.7	61.9	43.9	83	65.1	103.9	86.3		
	11	48.6	71.1					57.7	37.7	78.7	58.9	99.6	80.1		
12	53	77.5					53.4	31.5	74.4	52.7	95.3	73.9			
TBNS-105SK	5	30.3	45.4	59.9	44.5	92.1	75.5								
	6	36.4	54.7	54.7	36.5	86.3	67.1								
	7	42.6	63.8			80.6	58.7	111.9	88.8						

Mounting Connection and Dimension

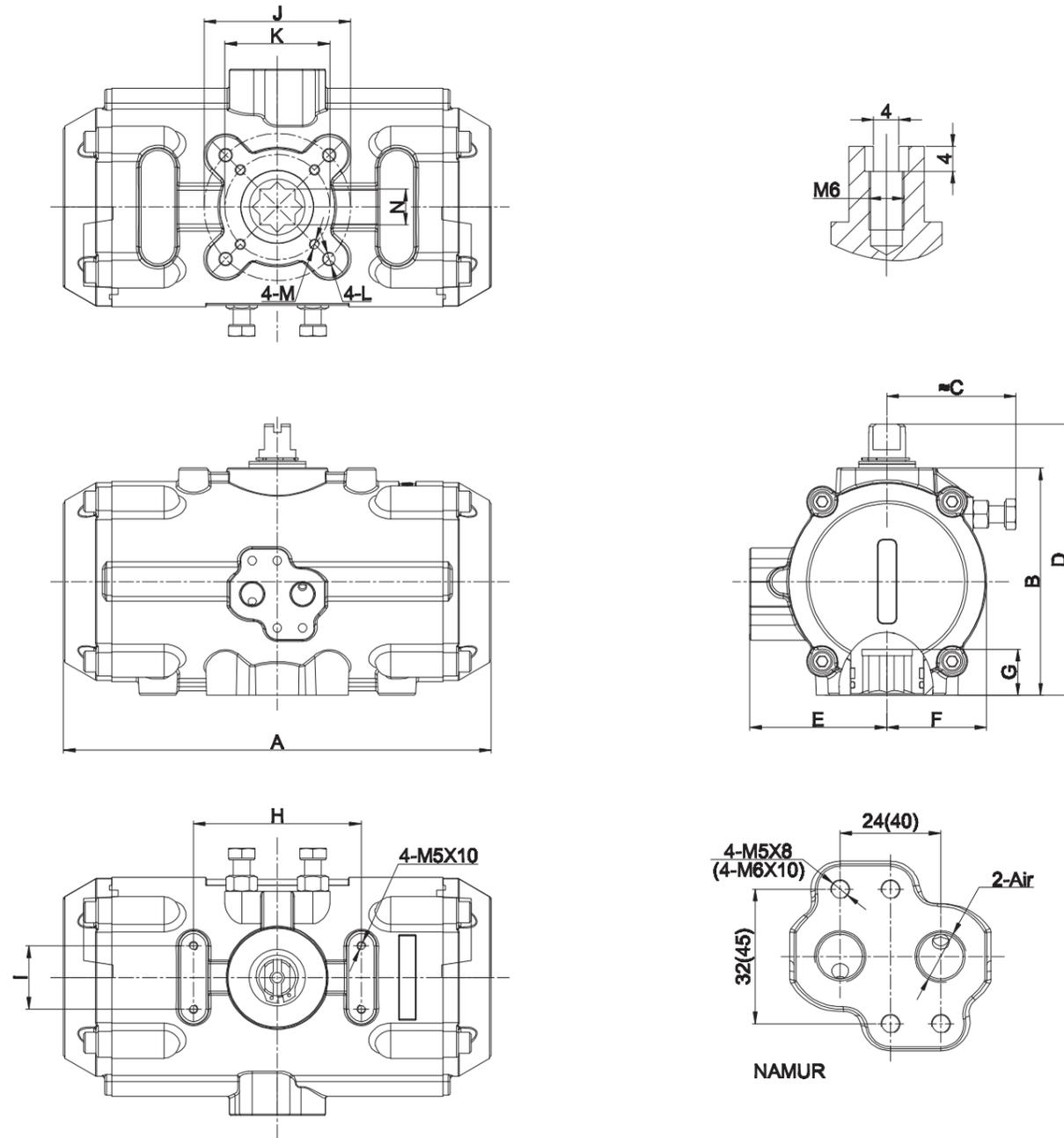

TBNS Series Actuator Dimension Table

Model	A	B	C	D	E	F	G	H	I	N	J	K	L	M	Air Connection
TBNS-052	146	72	45	92	47	32	13	80	30	11	Φ50	Φ36	M6*10	M5*8	G1/4"
TBNS-063	173	88	50	108	54	39	18	80	30	14	Φ70	Φ50	M8*13	M6*10	G1/4"
TBNS-075	184	99.5	60	119.5	61.5	44	19	80	30	14	Φ70	Φ50	M8*13	M6*10	G1/4"
TBNS-083	211	108	65	128	65.5	48	19	80	30	17	Φ70	Φ50	M8*13	M6*10	G1/4"
TBNS-092	262	118	65	138	73	52.5	22	80	30	17	Φ70	Φ50	M8*13	M6*10	G1/4"
TBNS-105	270	133	70	153	77	60	26	80	30	22	Φ102	Φ70	M10*15	M8*13	G1/4"
TBNS-125	302	155	80	185	87	69.5	27	130	30	22	Φ102	Φ70	M10*15	M8*13	G1/4"
TBNS-140	394	172	90	202	95.5	77	32	130	30	27	Φ125	Φ102	M12*20	M10*16	G1/4"
TBNS-160	456	198	100	228	106	89	32	130	30	27	Φ125	Φ102	M12*20	M10*16	G1/4"
TBNS-190	528	230	120	260	131	104	40	130	30	36	Φ140		M16*24		G1/4"
TBNS-210	532	255	140	285	140	115	40	130	30	36	Φ140		M16*24		G1/4"
TBNS-240	608	292	160	322	160	134	48	130	30	46	Φ165		M20*28		G1/4"
TBNS-270	714	331	160	361	180	147	48	130	30	46	Φ165		M20*28		G1/2"
TBNS-300	783	354	176	384	194	160	60	130	30	46	Φ165		M20*25		G1/2"
TBNS-350	926	414	215	444	227	188	60	130	30	46	Φ165		M20*25		G1/2"
TBNS-400	940	464	220	491	223	246	60	130	30	55	Φ254	Φ165	M16*25	M20*25	G1/2"

Mounting Standard



Air supply connection is designed in accordance with NAMUR Standard to install solenoid valves.



The Namur drive pinion and the Namur top mounting connection permit direct installation of accessories such as limit switch box and positioner.



Bottom mounting connection is designed in accordance with ISO5211 and DIN3337 standards for direct mounting with valve gear boxes or mounting brackets.