

Consider People As Boat,
Consider Seriousness As Her Helm,
And Consider Wisdom As Her Sail.



www.theoborn.com



Theoborn auto-control valves co.,ltd
ADD:No.119,4th Road,3rd Avenue,Binhai Industrial Zone,Wenzhou city
P.C:325025
TEL:+86-577-86378000 86830000
FAX:+86-577-86887882
E-mail:juen@theoborn.com
www.theoborn.com

Theoborn factory reserve the right to change technical
Characteristics without previous advice



TBNII Series Pneumatic Actuator



高新技术企业

Zhejiang Theoborn Auto-control Valves Co.,Ltd



THEOBORN

TBNII Series Pneumatic Actuator

Company Profile

Zhejiang Theoborn Auto-Control Valves Co.,Ltd. is dedicated to manufacturing pneumatic actuators and electric actuators.

Our products fundamentally transform the complex traditional usage of valves, incorporating high technology with the control process of valves, greatly improving the efficient usage of valves, largely diminishing the controlling cost, and obtaining considerable profits for enterprises. Our company is located



in Wenzhou City which possesses a long history of manufacturing valves and actuators. Inspired by our experience of manufacturing valves and actuators, supported by exquisite manufacturing technique, and enveloped with the special innovative consciousness and serious spirit, Theoborn endeavors to culminate the wisdom, aspires to make the best products, and desires to benefit human beings.

Theoborn people believe that we should consider people as boat, consider wisdom as helm and consider seriousness as sail. Theoborn believes that professional technology, along with sincere service, will obtain customers' hearts, win customers' credits, and move customers.



Consider people as a boat, consider seriousness as her helm, and consider wisdom as her sail.

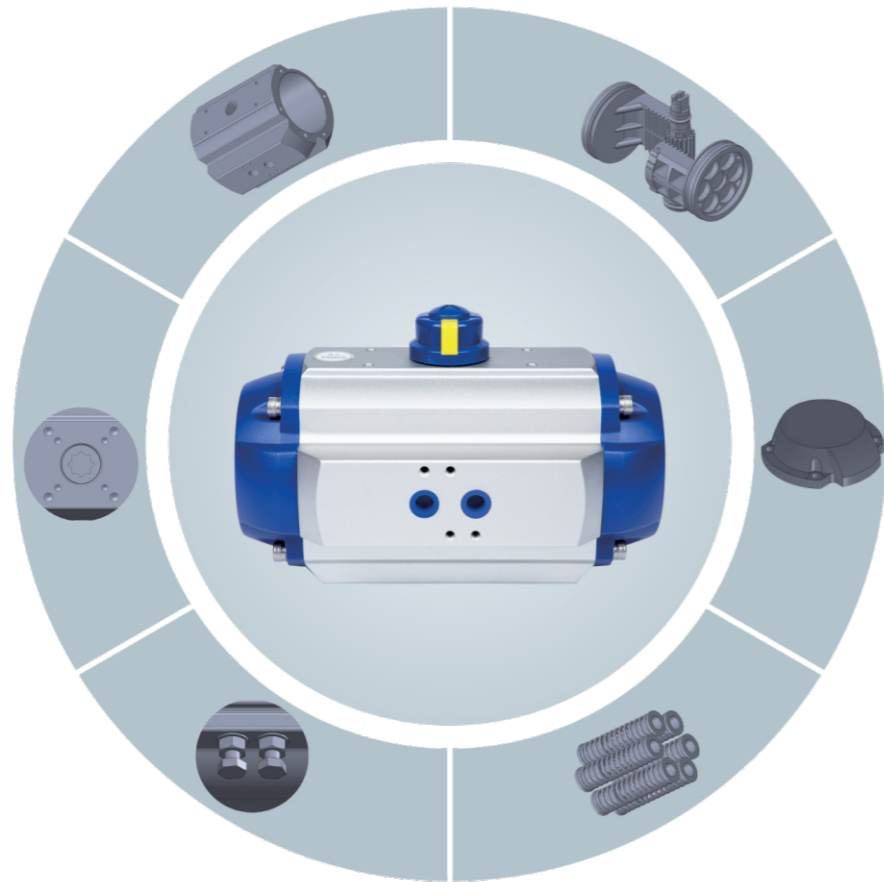

- 1、 Extruded aluminium body, with both internal and external hard anodized corrosion protection having honed cylinder surface for longer life and lower coefficient of friction.
- 2、 Dual piston rack and pinion design for compact construction, symmetric mounting position, high cycle life and fast operation, reverse rotation can be accomplished in the field by simply inverting the pistons.
- 3、 One-piece gear output shaft, with nickel plated, long service life. And can be customized size and stainless steel material as option.
- 4、 Die-cast aluminum alloy end caps, epoxy coated with high anti-corrosion performance. Can be customized various colors or PTFE coating.
- 5、 Two independent external travel stop adjustments. Permits an easy and precise adjustment of +/-5° in both directions, in the open and close positions for an accurate valve alignment.
- 6、 Selected high quality bearings and seal for low friction, high cycle life and a wide operating temperature range.
- 7、 Modular preloaded spring cartridge design. With coated spring for simple versatile range, greater safety and corrosion resistance.
- 8、 Internal and external stainless steel fasteners for long term corrosion resistance.
- 9、 ISO 5211, DIN 3337 and VDI/VDE 3845 NAMUR: Full conformance to the latest specifications: ISO 5211, DIN 3337 and VDI/VDE 3845 NAMUR for product interchangeability and easy mounting of solenoids, limit switches and other accessories.

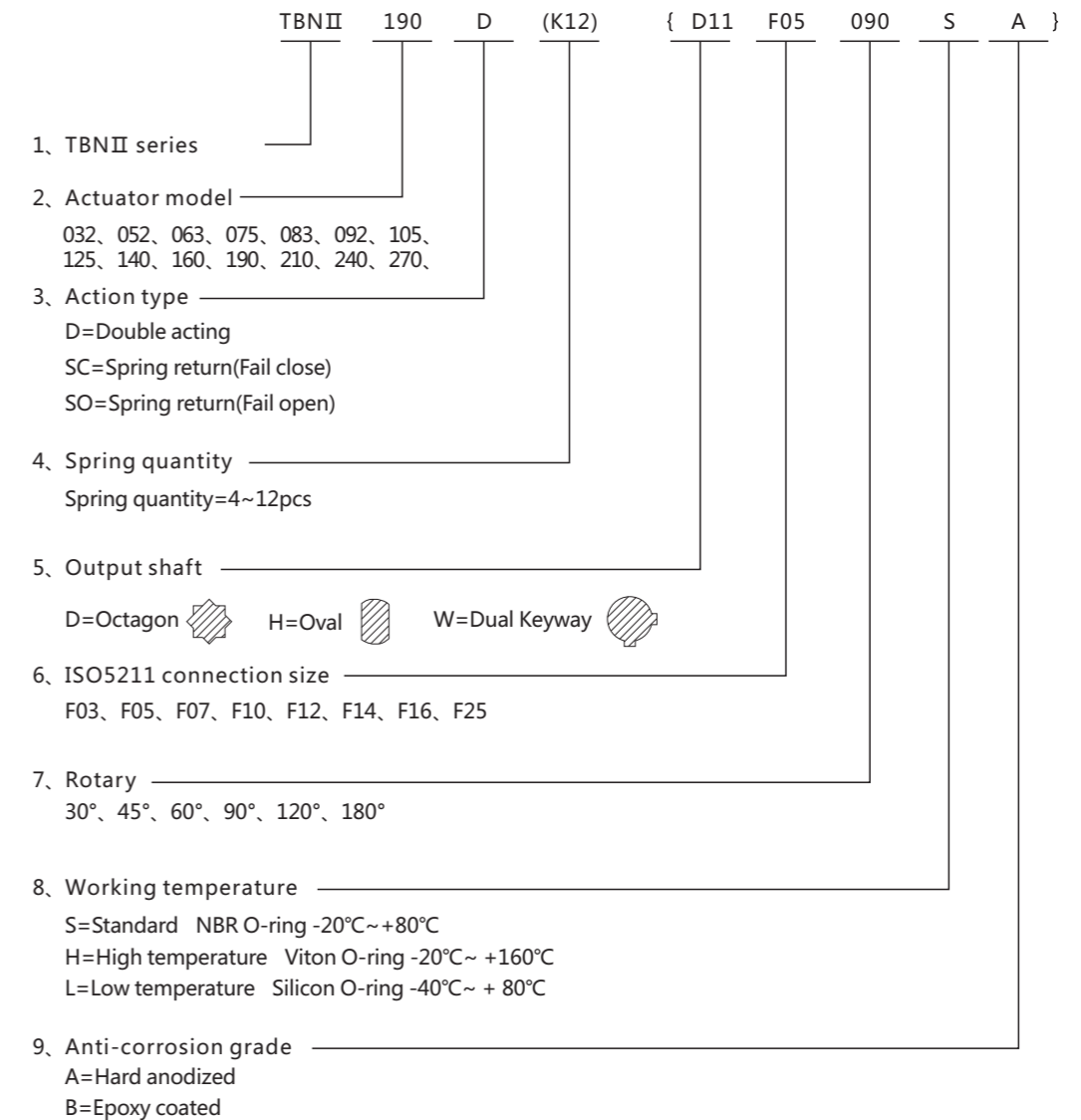

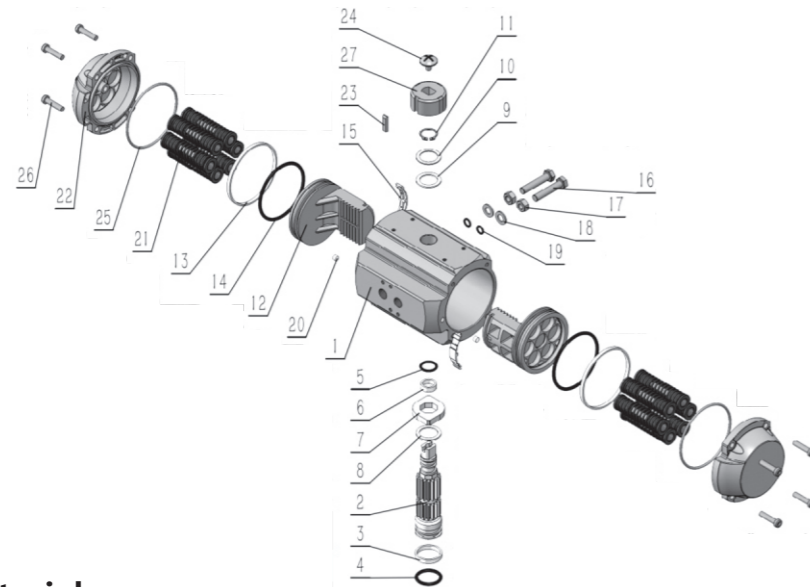

Parts and Materials

NO.	Description	Qty	Material	Material
1	Body	1	Aluminium Alloy	Anodized Oxygenation
2	Pinion	1	Alloy Steel	Nickel Plated
3	Bearing(Lower Pinion)	1	POM	
4	O-Ring(Lower Pinion)	1	NBR	
5	O-Ring(Top Pinion)	1	NBR	
6	Bearing(Top Pinion)	1	POM	
7	Spacer	1	Alloy Steel	
8	Thrust Bearing Pinion	1	POM	
9	Thrust Bearing Pinion	1	POM	
10	Thrust Washer(Pinion)	1	Stainless Steel	
11	Spring Clip	1	Stainless Steel	
12	Piston	2	Alloy Steel	Hard Anodized
13	Guide Ring(Piston)	2	POM	
14	O-Ring(Piston)	2	NBR	
15	Bearing Ring(Piston)	2	POM	
16	Adjusting Screw	2	Stainless Steel	
17	Adjusting Nut	2	Stainless Steel	
18	Washer(Adjusting Screw)	2	Stainless Steel	
19	O-Ring(Adjusting Screw)	2	NBR	
20	Plug	2	NBR	
21	Spring	4~12	Spring steel	Zinc Phosphate Coated
22	End Cap	2	Alloy Steel	Epoxy Coated
23	Adjusting Screw(End Cap)	2	Stainless Steel	
24	Adjusting Nut(End Cap)	2	Stainless Steel	
25	O-Ring(End Cap)	2	NBR	
26	Bolts(End Cap)	8	Stainless Steel	
27	Indicator	1	Engineering Plastics	
28	Nut(Indicator)	1	Engineering Plastics	

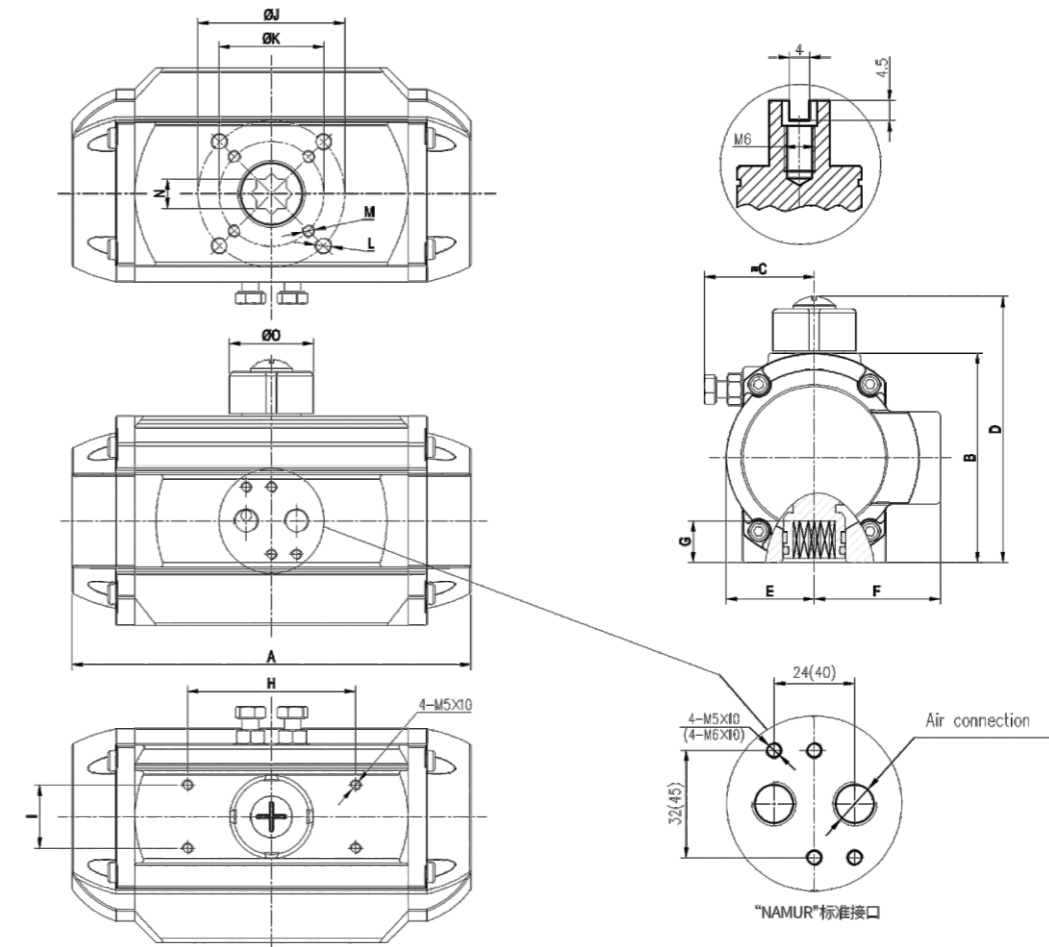

Model	A	B	C	D	E	F	G	H	I	J	K	L	M	N	O	Air
TBNII032	111	46	52	66	21	31	14	50	25	/	F03Φ36	/	M5X8	9	40	G1/8
TBNII052	154	74	45	99	30	47	14	80	30	F05Φ50	F03Φ36	M6X11	M5X10	11	40	G1/4
TBNII063	173	88	50	113	36	54	18	80	30	F07Φ70	F05Φ50	M8X14	M6X11	14	40	G1/4
TBNII075	190	100	55	125	42	60	20	80	30	F07Φ70	F05Φ50	M8X14	M6X11	14	40	G1/4
TBNII083	208	109	60	134	46	65	20	80	30	F07Φ70	F05Φ50	M8X14	M6X11	17	40	G1/4
TBNII092	254	120	70	145	51	70	22	80	30	F07Φ70	F05Φ50	M8X14	M6X11	17	40	G1/4
TBNII105	282	135	70	160	58	76	24	80	30	F10Φ102	F07Φ70	M10X18	M8X14	22	40	G1/4
TBNII125	312	155	80	182	68	87	28	80	30	F10Φ102	F07Φ70	M10X18	M8X14	22	65	G1/4
TBNII140	380	178	95	205	76	96	32	80	30	F12Φ125	F10Φ102	M12X22	M10X18	27	65	G1/4
TBNII160	426	197	100	224	87	107	34	80	30	F12Φ125	F10Φ102	M12X22	M10X18	27	65	G1/4
TBNII190	484	235	125	275	103	126	40	130	30	F14Φ140	/	M16X23	/	36	78	G1/4
TBNII210	532	260	130	300	113	137	40	130	30	F14Φ140	/	M16X25	/	36	78	G1/4
TBNII240	610	292	145	330	146	158	50	130	30	F16Φ165	/	M20X28	/	46	78	G1/2(1/4)
TBNII270	704	330	170	370	165	175	57	130	30	F16Φ165	/	M20X28	/	46	78	G1/2
TBNII300	782	352	308	385	160	170	50	130	30	F16Φ165	/	M20X25	/	46	80	G1/2
TBNII350	920	410	362	440	190	195	50	130	30	F25Φ254	F16Φ165	M16X24	M20X25	55	80	G1/2
TBNII400	935	460	446	494	260	260	60	130	30	F25Φ254	F16Φ165	M16X24	M20X25	55	80	G1/2

Unit:Nm

Model	(Bar) Air Pressure						
	2	3	4	5	6	7	8
TBNII032D	2.7	4.2	5.8	7.4	9.0	10.5	11.8
TBNII052D	7.9	11.9	15.9	19.9	23.8	27.8	31.7
TBNII063D	14.0	21.0	28.0	35.0	42.0	49.0	55.9
TBNII075D	19.8	29.7	39.6	49.5	59.4	69.2	79.1
TBNII083D	28.3	42.5	56.6	70.7	84.9	99.0	113.2
TBNII092D	44.7	67.1	89.5	118.9	134.2	156.6	179.0
TBNII105D	64.8	97.1	129.5	161.9	194.3	226.7	259.0
TBNII125D	101.0	151.4	201.9	252.4	302.9	353.4	403.8
TBNII140D	158.3	237.5	316.6	395.8	474.9	554.1	633.2
TBNII160D	225	338	451	564	677	790	902
TBNII190D	361	541	721	901	1082	1262	1442
TBNII210D	518	777	1036	1295	1554	1813	2072
TBNII240D	761	1142	1523	1903	2284	2665	3045
TBNII270D	1156	1734	2312	2891	3469	4047	4625
TBNII300D	1526	2289	3052	3815	4578	5341	6104
TBNII350D	2285	3427	4570	5712	6854	7997	9139
TBNII400D	3256	4884	6512	8140	9768	11396	13024



■ Dual action

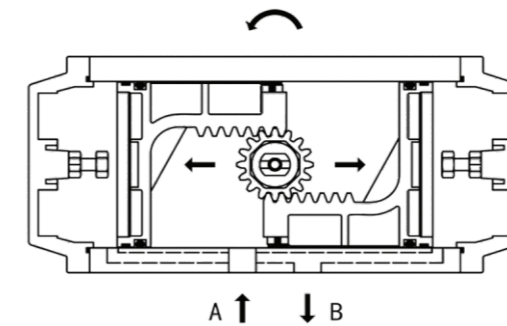

Air from Port A forces the pistons outwards, causing the springs to compress, the pinion turns counter-clockwise to open the valve while air is being exhausted from Port B.

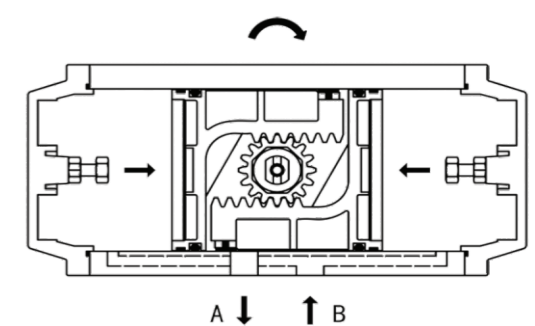

Air from Port B forces the pistons inwards, causing the springs to compress, the pinion turns clockwise to close the valve while air is being exhausted from Port A.

■ Spring return (FC)

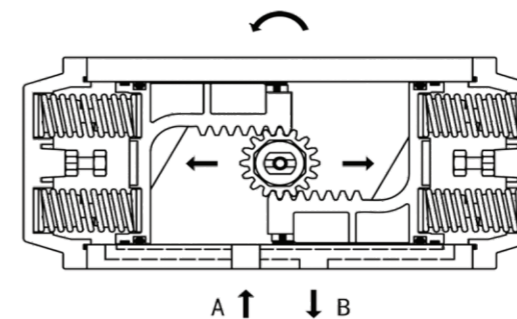

Air from Port A forces the pistons outwards, causing the springs to compress, the pinion turns counter-clockwise to open the valve while air is being exhausted from Port B.

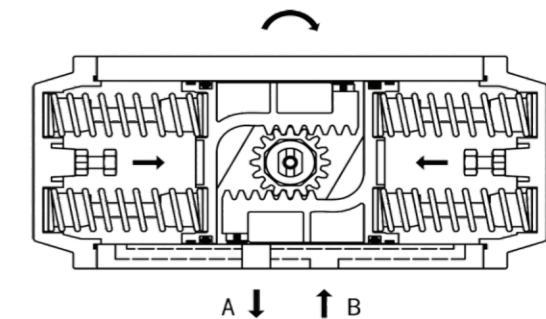

In case of air or power disruption, the rebound of springs forces the pistons inwards, the pinion turns clockwise to close the valve while air is being exhausted from Port A. Air from Port B can accelerate the close of the valve.

■ Spring return (F0)

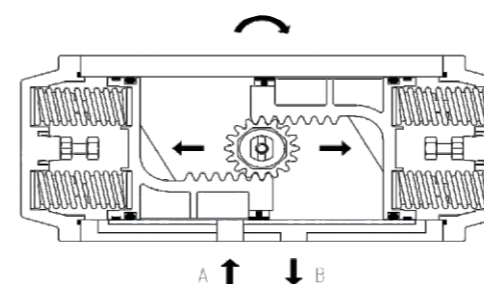

Air from Port A forces the pistons outwards, causing the springs to compress, the pinion turns clockwise to close the valve while air is being exhausted from Port B.

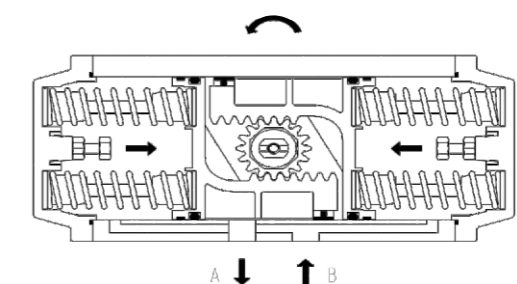

In case of air or power disruption, the rebound of springs forces the pistons inwards, the pinion turns counter-clockwise to open the valve while air is being exhausted from Port A. Air from Port B can accelerate the open of the valve.