



**XI'AN XICHI ELECTRIC CO., LTD.**

Headquarters address: 15/F, Block B, Xi'an National Digital Publishing Base, No.996 Tianguqi Road, High-tech Zone, Xi'an, China

Factory address: No.2 West Qinlingsi Road, Caotang Technology Industrial Base, High-tech Zone, Xi'an, China

Tel: +86-29-88626546

Web: [www.xichielectric.com](http://www.xichielectric.com)

Email: [support@xichielectric.com](mailto:support@xichielectric.com)

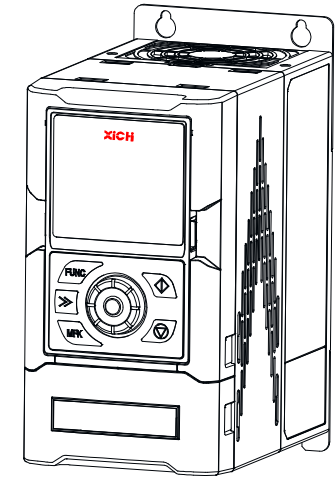


XICHI Frequency converter XFC550 Technical Manual

File No. : TDOC-XFC550-T-EN

[ Technical Manual ]

Please read through this technical manual for the safe use of the product.



**XICHI Frequency Converter XFC550**

High performance vector control

Power supply voltage: three-phase 380V-480V

Range of power: 1.5kW-450kW

©2018 Xi'an XiChi Electric Co., Ltd. All rights reserved

Reserve the final interpretation right V2.0

If the product's size and parameters change, the latest actual product shall prevail.



XI'AN XICHI ELECTRIC CO.,LTD.

## About the Manual

The manuals related to this converter are listed below. Please choose to use them as needed.

XFC550 series quick usage manual of XICHI Frequency converter

File No:TDOC-XFC550-Q-EN

This manual shall be attached to the converter in delivery

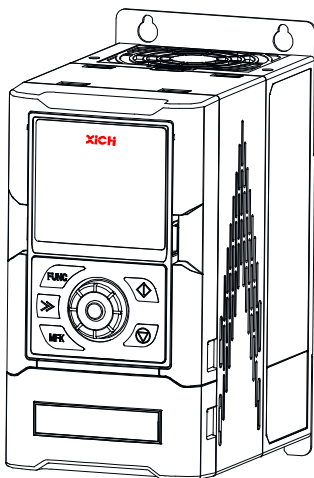
This manual covers the basic knowledge of this series product

XFC550 series technical usage manual of XICHI Frequency converter

File No:TDOC-XFC550-T-EN

According to customer demand

This manual covers the detailed knowledge of this series product



<b>Safety Information and Precautions</b>	<b>1</b>
<b>Product Information</b>	<b>2</b>
<b>Installation</b>	<b>3</b>
<b>Wiring</b>	<b>4</b>
<b>Operation</b>	<b>5</b>
<b>Functional parameter list</b>	<b>6</b>
<b>Details of Parameters</b>	<b>7</b>
<b>Fault Diagnosis and Troubleshooting</b>	<b>8</b>
<b>Maintenance</b>	<b>9</b>
<b>Peripheral Elements and Optional Parts</b>	<b>10</b>
<b>Communication protocol</b>	<b>A</b>
<b>The Corresponding Foreign Standards</b>	<b>B</b>

# Preface

Thank you for choosing XFC550 series frequency converter of Xi'an Xi Chi Electric Co., Ltd.

XFC550 series frequency converter is a universal high-performance current vector frequency converter independently developed by our company, which can realize the control and adjustment of asynchronous motor. XFC550 adopts high-performance vector control technology, featuring low speed, high-torque output, good dynamic characteristics, superior overload capability, and support for multiple function cards. It supports embedded and wall-mounted installations. With powerful and stable performance, it can be used for driving fans, pumps, and various automated production equipment in the field of textile, paper making, packaging, and food.

This manual introduces the features and usage of the XFC550 series frequency converter, including product features, type selection, structural features, installation wiring, operation, parameter functions, fault diagnosis, maintenance and servicing. Please read this manual carefully before you start the use of the machine. Please use this product on the premise of ensuring personal safety and mastering product safety precautions.

The product specifications used in this product are subject to change without notice. The user manual of this product should be kept properly until the frequency converter is out of use.

## IMPORTANT

1. Be sure to confirm that the rating on the nameplate of your machine matches your order.
2. Always ensure the integrity of the product shell and all safety covers installed.
3. The illustrations in this manual are for illustrative purposes only and may differ from the products you ordered.
4. Due to product updating, specification changes, and improvement of the user manual, the contents of the user manual will be changed.
5. If you have any problems during use, please contact our regional agent or directly contact our customer service center.
6. After the product is powered on, if there is any abnormality, stop the machine for inspection as soon as possible and seek technical service.



# content

<b>preface</b> .....	<b>I</b>
<b>content</b> .....	<b>II</b>
<b>1. Safety Information and Precautions</b> .....	<b>1</b>
1.1 Description of safety symbols .....	1
1.2 Precautions for using frequency converter.....	1
1.2.1 Type selection.....	2
1.2.2 Setting .....	3
1.2.3 Use .....	3
1.3 Precautions for use of motor .....	4
1.3.1 Standard motor.....	4
1.3.2 Special motor.....	5
1.3.3 Description of warning symbols.....	6
<b>2. Product Information</b> .....	<b>7</b>
2.1 Confirm information before use .....	7
2.1.1 Model description .....	7
2.1.2 Description of nameplate.....	8
2.1.3 Specification .....	8
2.2 System wiring .....	11
2.2.1 Instruction to use of peripheral elements.....	12
2.3 Components of frequency converter .....	13
<b>3. Installation</b> .....	<b>14</b>
3.1 Safety cautions and installation requirement.....	14
3.2 Dimensions and mounting dimensions.....	15
3.3 Mounting direction and space .....	16
3.3.1 Mounting direction .....	16
3.3.2 Mounting of single frequency converter.....	17
3.3.3 Installation of multiple frequency converters in parallel.....	17
3.3.4 Installation of top and down frequency converters .....	18
3.4 Wall-mounting and flush installation .....	19
3.4.1 Wall-mounting type .....	19
3.4.2 Embedded installation .....	19
3.5 Installation of operating panel .....	21
<b>4. Wiring</b> .....	<b>22</b>
4.1 Installation precautions and installation site requirements .....	22
4.2 Standard wiring diagram .....	23
4.3 Removal and installation of operating panel and cover plate .....	23
4.3.1 Removal and installation of operating panel .....	23
4.3.2 Removal and installation of bottom cover.....	24
4.3.3 Removal of wiring baffle .....	25



---

4.4 Main circuit .....	25
4.4.1 Functions of main circuit terminals .....	26
4.4.2 Wire size and tightening torque for main circuit wiring .....	26
4.4.3 Connection of the motor to the main circuit terminals .....	28
4.4.4 Wiring distance between the frequency converter and the motor .....	28
4.4.5 Grounding mode .....	28
4.4.6 Power grid system requirements for main circuit connection .....	28
4.5 Control circuit .....	29
4.5.1 Functions of control circuit terminals .....	29
4.5.2 Wire size and tightening torque for control loop wiring .....	31
4.5.3 Wiring for control circuit terminal block .....	31
4.5.4 Control circuit grounding .....	31
4.6 Connection of input/output signals .....	32
4.6.1 Analog input terminals AI1 and AI2 .....	32
4.6.2 DI terminal .....	33
4.6.3 DO terminal .....	34
<b>5. Operation .....</b>	<b>36</b>
5.1 Safety precautions .....	36
5.2 Description of operating panel .....	36
5.2.1 Components of operating panel and functions .....	36
5.2.2 Correspondence table of number and characters .....	38
5.2.3 Description of LED indicators .....	39
5.2.4 Hierarchy of operating panel's display function .....	39
5.2.5 Frequency command setting .....	40
5.3 Control board's indicator .....	40
5.4 Operating steps before running the frequency converter .....	41
5.5 Confirmation of power on and display state .....	42
5.5.1 Power on .....	42
5.5.2 Display state .....	43
5.6 Test run .....	43
5.6.1 Test run under no-load condition .....	43
5.6.2 Test run with load .....	44
<b>6. Functional parameter list .....</b>	<b>45</b>
6.1 Description of parameter's access authority .....	45
6.2 Quick Start Parameters Table .....	45
6.3 Parameters list of function code .....	47
<b>7. Details of Parameters .....</b>	<b>91</b>
7.1 Group b: System parameters .....	91
7.1.1 b0: Basic system parameters .....	91
7.2 Group C: Power control parameters .....	93
7.2.1 C0: Power control parameters .....	93
7.2.2 C1: The 1st motor's parameters .....	96
7.2.3 C2、C3、C4: The 2nd, 3rd and 4th motor's parameters .....	102

---

7.2.4 C5: V/F control parameters .....	102
7.2.5 C6: Vector control parameters.....	105
7.3 Group F: Function control parameters.....	108
7.3.1 F0: Control and set parameters.....	108
7.3.2 F1: Input terminal's parameters .....	123
7.3.3 F2: Output terminal parameters.....	136
7.3.4 F3: AIAO calibration .....	146
7.3.5 F4: Multistage speed and simple PLC parameters .....	148
7.3.6 F5: PID control parameters .....	151
7.3.7 F6: Expansion functional parameters .....	155
7.3.8 F7: Communication parameters .....	156
7.3.9 F8: Protection and fault parameters .....	156
7.4 Group P: Operating panel's parameters.....	164
7.4.1 P0: Universal keyboard's parameters.....	164
7.4.2 P1: LED keyboard's parameters .....	165
7.5 Group A: Application software's parameters .....	167
7.5.1 A0: Swing frequency, fixed length and count.....	167
7.5.2 A2: Virtual IO .....	169
7.6 Group U: Optional card's parameters.....	171
7.6.1 U0: User- programmable card's parameters .....	171
7.7 Group d: Monitor parameters .....	173
<b>8. Fault Diagnosis and Troubleshooting .....</b>	<b>178</b>
8.1 Fault .....	178
8.2 Common faults and treatment methods .....	184
<b>9. Maintenance .....</b>	<b>186</b>
9.1 Safety precautions.....	186
9.2 Daily maintenance and maintenance .....	186
9.3 Regular maintenance .....	187
9.4 Replacement of wearing parts.....	188
<b>10. Peripheral Elements and Optional Parts .....</b>	<b>189</b>
10.1 Expansion card.....	189
10.1.1 Installation of optional card.....	190
10.1.2 Wiring diagram of encoder card XFC550-EN1-00 .....	191
10.2 Method of connection with peripheral machines and precautions .....	195
10.2.1 Optional parts of braking resistor.....	195
10.3 Type selection of external bracket for embedded mounting brake unit .....	197
<b>A Communication protocol.....</b>	<b>198</b>
<b>B The Corresponding Foreign Standards .....</b>	<b>207</b>
<b>History of version change .....</b>	<b>212</b>
<b>Warranty Agreement .....</b>	<b>213</b>

# 1. Safety Information and Precautions

## 1.1 Description of safety symbols

### PRECAUTIONS

✓The legends in this manual are for illustrative purposes only and may differ slightly from the products you ordered.


✓To describe the details of the product, the legends in this manual sometimes show the state of removing the cover or the safety cover. When operating this product, be sure to install the cover and safety cover as required and follow the instructions in the technical manual.

### WARNING

✓Please read this manual carefully before installing, wiring, operating, and inspecting the frequency converter. Please install the frequency converter according to the manual.

✓This manual uses the following symbols to indicate that it is an important part of safety. Failure to follow these precautions can result in death, serious injury, and damage to the product and related equipment systems.

 **DANGER** Marked as dangerous information which is essential to avoid safety incidents.

 **WARNING** Marked as dangerous information which is necessary to avoid damage to the product or other equipment.

 **ATTENTION** Marked as dangerous information which helps ensure proper product operation.

1

## 1.2 Precautions for using frequency converter

### DANGER

✓Please pay attention to all the information in this manual.

✓Failure to follow the warnings may result in serious injury or even death, so please pay attention.

✓The company is not responsible for any injury or loss caused by the user's failure to comply with the contents of this manual.

✓Do not perform wiring work while the power is on, otherwise there is a risk of electric shock.

✓In order to prevent electric shock, please confirm that the wiring breaker (MCCB) and the electromagnetic contactor (MC) are in the OFF state before wiring, otherwise there is a risk of electric shock.

✓Before performing the inspection, cut off the power of all equipment and wait for 10 minutes before operation.

 **WARNING**

- ✓ Before powering on the frequency converter, please make sure that there are no people around the equipment and motor to prevent injury caused by sudden operation of the equipment.
- ✓ It is strictly forbidden to modify the frequency converter. The company is not responsible for any loss or casualty caused by the user's transformation.
- ✓ Non-professional or untrained personnel should not perform maintenance, inspection or parts replacement.
- ✓ Do not remove the frequency converter while the power is on.
- ✓ Confirm that the rated voltage of the frequency converter is consistent with the power supply voltage before power-on.

---

**ATTENTION**

- ✓ When handling the frequency converter, be sure to grasp the housing to prevent the main body from falling, causing injury or death.
- ✓ When operating the frequency converter, follow the procedures specified in the static electricity prevention measures (ESD).
- ✓ The withstand voltage test is not possible for each part of the frequency converter.
- ✓ Do not run an equipment that is already damaged.
- ✓ Do not power on or operate the equipment immediately when the fuse blows or the wiring breaker trips. Check the cable connections and whether the correct type is selected. If you are unsure of the cause, please contact the company in time. Do not connect the power or operate the equipment randomly.

1

---

### 1.2.1 Type selection

#### Capacity of frequency converter

When running a special motor, please make sure that the rated current of the motor is not higher than the rated output current of the frequency converter. In addition, when multiple induction motors are operated in parallel with a frequency converter, the total rated current of the motor should be 1.1 times smaller than the rated output current of the frequency converter in selecting the capacity of the frequency converter.

#### Reactor

The use of DC reactors or AC reactors helps to improve the grid side power factor, suppress peak currents in the power input loop, and reduce harmonics in the input current. 11K0 and above machines are built in DC reactors. Users can use input AC reactors according to the actual conditions of the input power supply.

#### Emergency stop

Although the protection function will be activated when the frequency converter fails, the output will stop, but the motor will not stop suddenly. Therefore, please install a mechanical stop and holding structure on the mechanical equipment that requires an emergency stop.

#### Pull-in torque

The starting and accelerating characteristics of the motor driven by the frequency converter are limited by the combined overload rated current of the frequency converter. Compared with the starting

of the general power frequency power supply, the torque characteristics are small. If a large starting torque is required, increase the capacity of the frequency converter by one stage or increase the capacity of the motor and frequency converter at the same time.

## 1.2.2 Setting

### Upper limit

The maximum output frequency of this frequency converter can be set to 500Hz. If the setting is wrong, the motor will run at high speed, which is very dangerous. Please set the upper limit via the upper limit frequency setting function. (The maximum output frequency in delivery is set to 50 Hz.)

### DC braking

If the value of DC braking current and operating time is set too large, the motor will overheat.

### Acceleration-deceleration time

The acceleration and deceleration time of the motor is determined by the torque and load torque generated by the motor and the inertia moment of the load. When preventing the stall function during acceleration/deceleration, reset the longer acceleration/deceleration time. Moreover, the acceleration/deceleration time will be extended as the time to prevent the stall function. If you want to further shorten the acceleration and deceleration time, please add optional brake resistor and brake unit (For 30K0 and above) or increase the capacity of the motor and frequency converter at the same time.

## 1.2.3 Use

### Wiring inspection

If the power supply is connected to the output terminals U, V, W of the frequency converter, which will be damaged. Before power-on, carefully check the wiring and wiring sequence for errors. Check for short circuit and wiring errors in the control circuit terminals. Failure to do so may result in malfunction or fault.

### Three-phase input cannot be changed to two-phase input.

### Thermal protection of motor

If the selected motor does not match the rated capacity of the frequency converter, be sure to adjust the related parameters for motor's protection in the frequency converter or install a thermal relay to the motor.

### Installation and selection of wiring circuit breaker or earth leakage circuit breaker

In order to protect the wiring of the frequency converter and prevent secondary losses in the event of an accident, it is recommended to install an earth leakage circuit breaker (ELCB). In addition, if the upper power system allows to cut off the leakage, a wiring breaker (MCCB) can also be used.

When selecting an ELCB, it is recommended to use an earth leakage circuit breaker for high-frequency leakage current. When selecting MCCB, it is necessary to consider the power factor of the power supply side of the frequency converter (varies according to the power supply voltage, output frequency, and load).

### Installation of electromagnetic contactor

In order to cut off the power supply to the frequency converter, it is recommended to install a magnetic contactor (MC). When installing the magnetic contactor, please design a circuit that disconnects the MC through the fault contact output of the frequency converter. When setting MC on the power supply side, do not start and stop the MC frequently. Failure to do so will result in malfunction of the frequency converter. When switching the ON/OFF by MC, please set it to a maximum of 1 time in 30 minutes.

### Maintenance and inspection

The built-in capacitor requires a certain discharge time even if the power supply to the frequency converter is cut off. Therefore, when checking, cut off the power supply and wait until the time indicated on the frequency converter has elapsed before starting the operation. Otherwise, if there is residual voltage on the capacitor, it may cause electric shock.

The heat sink of the frequency converter will generate high temperature and should not be touched. Otherwise there is a risk of burns.

Please cut off the power supply to the frequency converter for more than 10 minutes, and make sure that the heat sink is sufficiently cooled before replacing the cooling fan.

When performing operations on live parts, be sure to pay attention to the following items.

1. If the frequency converter is in the stop state and the motor is still driven by the load, be sure to install a low voltage manual switch on the output side of the frequency converter.
2. When performing maintenance, inspection and wiring, please cut off the output side low voltage manual switch and wait until the time indicated on the frequency converter has started.
3. Do not turn on/off the low voltage manual switch while the motor is running, otherwise the frequency converter will be damaged.
4. When the low voltage manual switch needs to be turned on during free running of the motor, please power on the frequency converter first, and then operate when the frequency converter is stopped.

### Transportation or Installation

1. Do not fumigate the frequency converter.
2. Do not expose the frequency converter to halogens (fluorine, chlorine, bromine, iodine, etc.) or DOP gases (phthalates) under any circumstances of transportation or installation.
3. In areas where the altitude is more than 1000m, the heat dissipation effect of the frequency converter deteriorates due to the thin air, so it is necessary to derate the equipment for use. Please contact our professional staff for this situation.
4. For the use of frequent lightning, please add lightning protection device to the frequency converter.

## 1.3 Precautions for use of motor

### 1.3.1 Standard motor

#### Insulation withstand voltage

When the input voltage is high (above 440V) or the wiring distance is long, the insulation withstand voltage of the motor must be considered. For details, please contact the motor manufacturer.

#### High-speed running

When it is used under conditions higher than the motor's rated speed, dynamic balance and poor bearing durability may occur. Please contact the motor manufacturer for more information.

#### Torque characteristics

The torque characteristics are different when the motor is respectively driven by a frequency converter and power-frequency power supply, it is necessary to confirm the load torque characteristics of the connected machine.

### **Vibration**

The XFC550 series of frequency converters can use high carrier modulation PWM control (depending on the parameters, low carrier modulation PWM control can also be selected). When high carrier modulation PWM control is selected, the vibration of the motor will be reduced, which is basically the same as when it is driven by the power frequency power supply. However, the vibration will increase slightly in the following cases.

- Resonance with the vibration frequency inherent in the mechanical system

Attention should be paid when changing a motor that runs at a constant speed to run at variable frequencies. In this case, it is effective to install anti-vibration rubber or perform frequency jump control under the motor frame.

### **Noise**

The noise varies depending on the carrier frequency. When the motor runs at a high carrier frequency, it is basically the same as that with power-frequency power supply, but operation above the rated speed will generate large wind noise.

## **1.3.2 Special motor**

### **Explosion proof motor**

When a pressure-proof explosion-proof motor is being driven, it is necessary to conduct the explosion-proof test for the combination of the motor and the frequency converter, and the same applies to the existing explosion-proof motor. In addition, since the frequency converter body is not explosion-proof, please install it in a safe place.

### **Gear drive motor**

The gear drive motor has different rotation ranges depending on the lubrication method and the manufacturer. Especially when oil lubrication is applied, there is a risk of sintering only at low speed. In addition, for the application of running at a high speed of 50 Hz or higher, please contact the manufacturer.

### **Variable-pole motor**

The rated current of the pole-changing motor is different from that of the standard motor. Please confirm the maximum current of the motor and select the corresponding frequency converter. Be sure to switch the poles after the motor has stopped. If switching is performed during rotation, the regenerative overvoltage or overcurrent protection circuit will operate and the motor will stop running freely.

### **Underwater motor**

The rated current of the underwater motor is larger than that of the standard motor, so be careful when selecting the frequency converter capacity. In addition, when the wiring distance between the motor and the frequency converter is long, the maximum torque of the motor will decrease due to the voltage drop, so use the cable thick enough for wiring.

### **URAS vibration motor**

The URAS vibration motor rotates with weight droppers (unbalanced weight) attached to the two shaft ends of the motor rotor and outputs the centrifugal force as vibration force. When the frequency converter is used to drive the motor, attention should be paid to the following items and select the capacity of the frequency converter. For specific selection method, please contact our agent or sales manager.

- URAS vibration motor should be used below the rated frequency.
- The control mode of the frequency converter uses V/f control .
- Since the vibration torque (load inertia) is as high as 10 to 20 times the motor inertia, set the acceleration time to 5~15s.
- Due to the large torque of the eccentric torque part (the static friction torque starting from a standstill), sometimes it may be unable to start for insufficient torque.

### **Motor with brake**

When a frequency converter is used to drive a motor with a brake, if the brake circuit is directly connected to the output side of the frequency converter, the brake will not be enabled due to the low voltage at startup. Please use a motor with brake powered separately to connect the brake's power supply to the side of the frequency converter. In general, when a motor with a brake is used, the noise in the low speed range may become high.

### **Power transmission structure (reducer, belt and chain)**

When an oil-lubricated gearbox and reducer are used in the power transmission system, if the engine only continuously operates at a low speed, the oil lubrication effect will be deteriorated. In addition, when performing high-speed operation of 50 Hz or more, attention should be paid to problems such as noise produced by the power transmission structure, strength due to centrifugal force, and reduced life.

### **1.3.3 Description of warning symbols**

Fig. 1-1 shows the frequency converter Warning symbol, be sure to follow the Warning symbol when using the frequency converter.

1



**Fig. 1-1 Warning symbol**

### **WARNING**

Risk of electric shock

Be sure to read through this technical manual before operation

Please wait for 10 minutes after powering down.



## 2. Product Information

### 2.1 Confirm information before use

When the product is received:

1. Make sure that the rating indicated on the nameplate of this machine is consistent with your ordering requirements;
2. If you find that the product is in bad conditions, please contact our agent in time.

#### 2.1.1 Model description

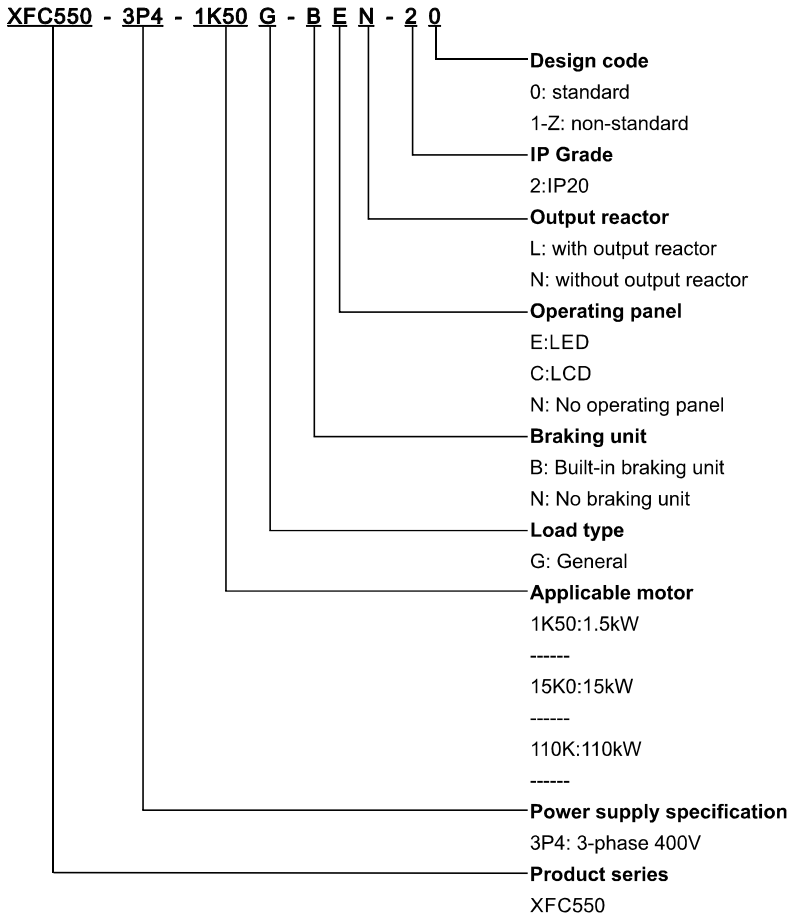


Fig. 2-1 Model description of frequency converter

2.1.2 Description of nameplate



Fig. 2-2 Description of frequency converter's nameplate

2.1.3 Specification

Table 2-1 Technical parameters of XFC550

Model XFC550-3P4-□	Motor power kW	Rated input capacity kVA	Rated input current A	Rated output current A
1K50	1.5	3.2	4.8	4
2K20	2.2	4.5	6.8	5.6
4K00	4	7.9	12	9.7
5K50	5.5	11	16	13
7K50	7.5	14	21	17
11K0	11	16	24	25
15K0	15	21	32	33
18K5	18.5	26	39	40
22K0	22	29	44	45
30K0	30	39	60	61
37K0	37	48	73	74
45K0	45	58	88	90
55K0	55	71	107	109
75K0	75	96	145	147
90K0	90	114	174	176
110K	110	139	211	211
132K	132	167	253	253
160K	160	201	306	303
185K	185	233	353	350
200K	200	250	380	378
220K	220	275	418	416
250K	250	312	474	467
280K	280	350	531	522
315K	315	393	597	588
355K	355	441	669	659
400K	400	489	743	732
450K	450	550	835	822

Built-in DC reactor for 11K0 and above models.

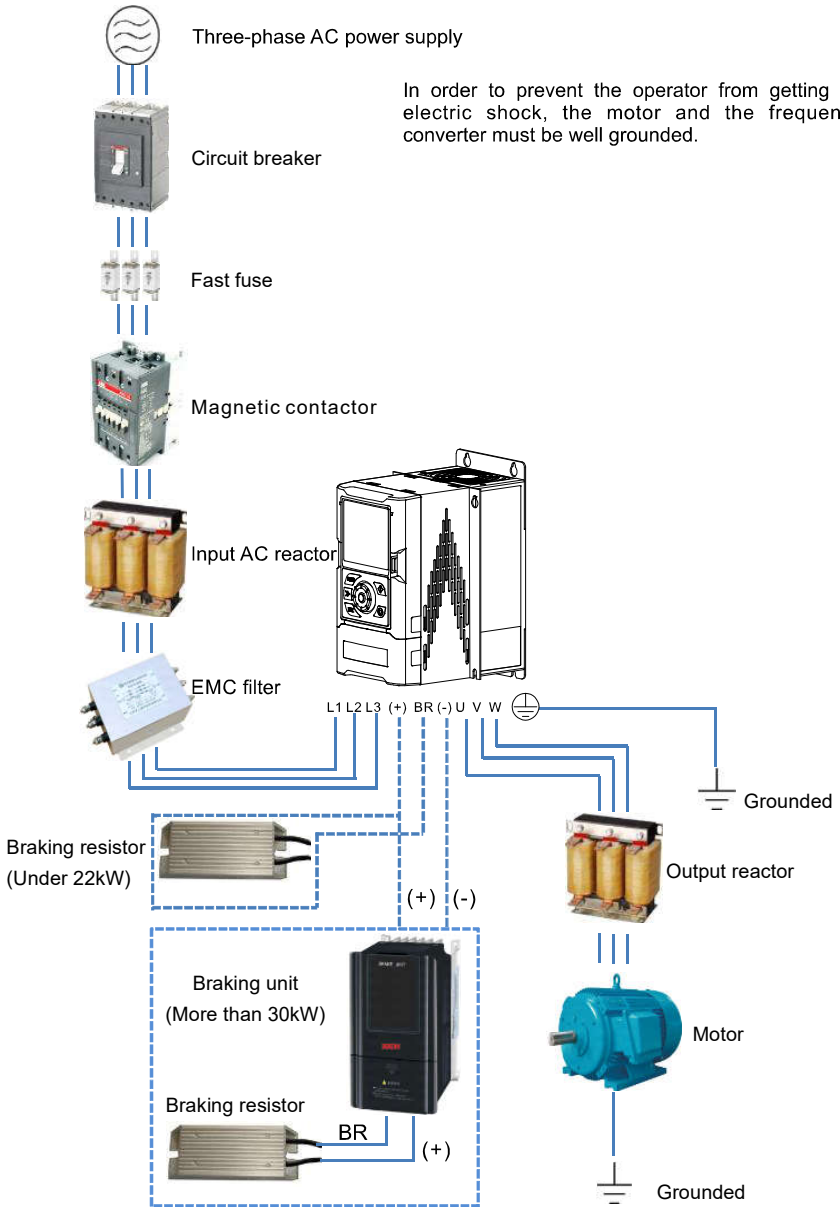
Table 2-2 Technical specification of XFC550

Item		Specification
Power supply	Rated voltage	3-phase 380~480V
	Allowable voltage fluctuation	-15%~+10%
	Rated frequency	50~60Hz
	Allowable frequency fluctuation	± 5%
Output	Max output voltage	Go after input voltage
	Max output frequency	500Hz
	Carrier frequency	0.5~16kHz (Automatic adjustment as per temperature. The adjustment range differs for different types)
	Overload capacity	150% rated current 60s 180% rated current 3s
Basic functions	Frequency setting resolution	Digital setting: 0.01Hz Analog setting: max frequency × 0.025%
	Control mode	Open-loop vector control (SVC) Closed-loop vector control (FOC) V/F control
	Pull-in torque	0.3Hz/150% (SVC) 0Hz/180% (FOC)
	Speed range	1:200 (SVC) 1:1000 (FOC)
	Speed stabilizing accuracy	± 0.5% (SVC) ± 0.02% (FOC)
	Control accuracy of torque	± 5% (SVC)
	Torque boost	Automatic torque boost Manual torque boost 0.1%~30.0%
	V/F curve	Three modes: straight line type; multipoint type; Nth power type V/F curve(1.2th power, 1.4th power, 1.6th power, 1.8th power, 2th power)
	Acceleration-deceleration curve	Straight line or S curve acceleration-deceleration method; four kinds of acceleration-deceleration time, acceleration-deceleration range: 0.0~6500.0s
	DC braking	DC braking frequency: 0.00Hz~max frequency Braking time: 0.0s~36.0s Braking action current value: 0.0%~100.0%
	Jogging control	Jogging freq. range: 0.00Hz~50.00Hz Jogging acceleration-deceleration time: 0.0s~6500.0s
	Simple PLC, multistage speed operation	Up to 16-stage speed operation via built-in PLC or control terminal
	Built-in PID	Closed-loop control realized in process control application
	Overvoltage and overcurrent stall control	Automatically limit current and voltage during operation to prevent shutdown due to frequent overcurrent and overvoltage
Fast current-limiting function	Minimize shutdown due to overcurrent to ensure the normal operation of frequency converter	

## 2. Product Information

	Item	Specification
Control interface	Digital input	5 multi-functional digital inputs, of which, one supports max 100kHz pulse input
	Analog input	2 analog inputs, both supporting 0~10V or 0~20mA analog input, switch voltage or current input via jumper
	Digital output	2 open collector digital outputs, of which, one supports max 100kHz square wave output
	Analog output	1 analog output, supporting 0~10V or 0~20mA analog input, switch voltage or current input via jumper
	Relay output	1-way relay output, including 1 normally-open contact and 1 normally-closed contact
	Standard comm. interface	1-way RS485 comm. Interface
Expansion interface	Functional expansion interface	Connectable to IO expansion card and PLC programmable expansion card
	Coder expansion interface	Connectable to compatible difference and OC coder expansion card
Operating interface	LED digital display	5-digit display of parameter and setting
	Indicator lamp	4 status indications and 3 unit indications
	Button's function	5 functional buttons, including 1 multi-functional button. Function can be set via parameter P0-00
	Shuttle knob	Add and minus plus confirm
	Parameter copy	Fast upload and download of parameters
Protection function	Basic protection	Phase loss, overvoltage, undervoltage, overcurrent, overload, overheat, interphase short circuit, grounding fault
Environment	Operation condition	Indoor without conductive dust and oil dirt
	Operational ambient temperature	-10℃~40℃(40℃~50℃ Derate 1.5% when the temperature rises by 1℃)
	Humidity	Less than 95%RH, without condensation
	Altitude	No derating less than 1000m, 1% derating when the altitude every rises by 100m
	Ambient temperature for storage	-20℃~+60℃
	Vibration	Less than 5.9m/s <sup>2</sup> (0.6g)
	Installation mode	Wall-mounted or embedded installation in cabinet (installation accessories needed)
	IP grade	IP20

## 2.2 System wiring



2

Fig. 2-3 External wiring of the system

### 2.2.1 Instruction to use of peripheral elements

Table 2-3 Instruction to use of peripheral elements of XFC550 series frequency converter

Name of accessories	Position of installation	Description of function
Circuit breaker	Front end of input loop	Break power supply in case of overcurrent of downstream equipment
Electromagnetic contactor	Input side of air switch and frequency converter	The frequency converter should avoid frequent power-on and -off operation or direct start operation through the contactor.
Input AC reactor	Input side of frequency converter	Improve the power factor on the input side; effectively eliminate the higher harmonics on the input side, prevent damage to other equipment caused by voltage waveform distortion; eliminate input current imbalance caused by power phase imbalance.
EMC filter	Input side of frequency converter	Reduce the external conduction and radiation interference of the frequency converter; reduce the conduction interference from the power supply end to the frequency converter, and improve the anti-interference ability of the frequency converter.
DC reactor	XFC550 series frequency converter. DC reactors of 11K0 and above are standard configuration	Improve the power factor on the input side; improve the efficiency and thermal stability of the frequency converter; effectively eliminate the influence of the higher harmonics on the input side of the frequency converter and reduce external conduction and radiation interference.
AC output reactor	Installed close to frequency converter between output side of frequency converter and motor	The output side of the frequency converter generally contains more high-order harmonics. When the distance between the motor and the frequency converter is long, as there is a large distributed capacitance in the line, the harmonics may generate resonance in the loop, bringing about effects in two aspects; destroy the insulation performance of the motor, and damage the click function. Large leakage current will cause frequent protection of the frequency converter; when the distance between the frequency converter and the motor is too long, it is recommended to install an output AC reactor.

1. Do not install capacitors or surge suppressors on the output side of the frequency converter. This will result in malfunction of the frequency converter or damage to the capacitor and surge suppressor.

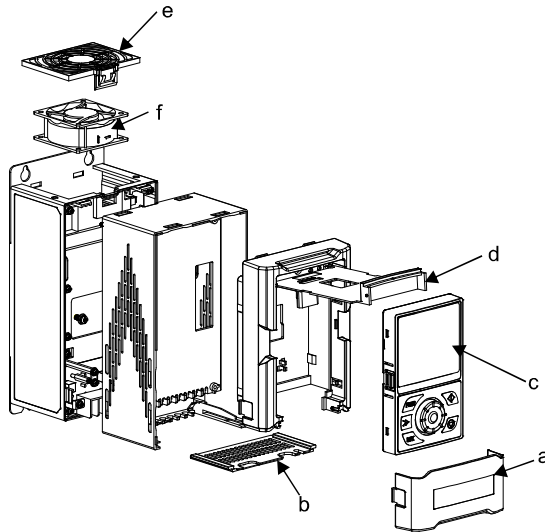
2. The input/output (main circuit) of the frequency converter contains harmonics that may cause interference to the communication equipment near the frequency converter. Therefore, install an anti-interference filter to minimize interference.

3. Refer to section 10 for peripheral components and options for details of peripheral devices and options.

#### ATTENTION:

Frequent ON and OFF may cause the frequency converter to malfunction. Considering the service life of the relay contacts and electrolytic capacitors inside the frequency converter, the maximum running and stopping frequency should not exceed 30 minutes. Please try to run and stop the motor through the operation of the frequency converter.

## 2.3 Components of frequency converter



- a-Bottom cover
- b-Wiring back plate
- c-Operating panel
- d-Rotational push plate
- e-Fan cover plate
- f-Fan

**Fig. 2-4 Parts of frequency converter**

## 3. Installation

### 3.1 Safety cautions and installation requirement



#### DANGER

- ✓ Do not install if the components of the frequency converter are incomplete or damaged.
- ✓ The frequency converter should be installed on a flame-retardant object such as metal and kept away from flammable and explosive objects.
- ✓ The operation should be performed 10 minutes after the frequency converter is disconnected from the power supply.



#### Warning

- ✓ When transporting, please firmly hold the bottom of the frequency converter, not just the operating panel or cover.
- ✓ Do not drop the debris produced in drilling holes into the frequency converter during installation.

Confirm that the installation site meets the following conditions:

1. Avoid installation in places where there is direct sun shining, damp, or water;
2. Avoid installation in places with oily dust, fibers and metal particles;
3. Vertically mounted on an object that is flame retardant and can withstand the weight of the body;
4. There is enough heat dissipation space around the frequency converter to ensure the ambient temperature is within -20~ 50 °C;
5. The installation base is solid enough to meet the vibration requirements of the product, and the vibration is less than 5.9 m/s<sup>2</sup> (0.6g).

3

---

#### ATTENTION:

The higher the ambient temperature, the shorter the life of the frequency converter.

Installation in a well ventilated area or with additional cooling device to increase the reliability of the frequency converter.

Do not install equipment such as transformer that generates electromagnetic waves or interference around the frequency converter. Otherwise, the frequency converter will malfunction.

To install such a device, a shield should be placed between it and the frequency converter.

---



## 3.2 Dimensions and mounting dimensions

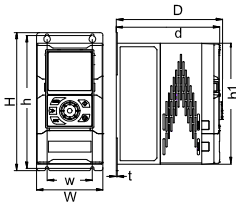


Fig. 3-1 Outside view A

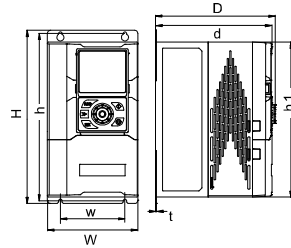


Fig. 3-2 Outside view B

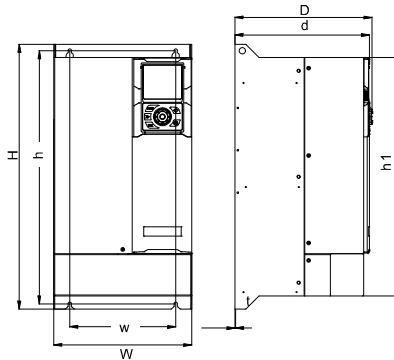


Fig. 3-3 Outside view C

Table 3-1 Dimensions

Model XFC550-3P4-□	Dimensions (mm)										
	Outside view	W	H	D	w	h	h1	d	t	Set screw	Weight (kg)
1K50	A	110	228	177	75	219	200	172	1.5	M5	2.5
2K20											
4K00											
5K50	B	140	268	185	100	259	240	180	1.5	M5	3.2
7K50											
11K0											
15K0											
18K5											
22K0	C	190	348	245	150	339	320	240	1.5	M5	9
30K0											
37K0											
45K0											
55K0											
75K0											
90K0											
110K											
132K		350	661	350	250	634	611	345	2	M10	61.5
160K		450	850	355	300	824	800	350	2	M10	91

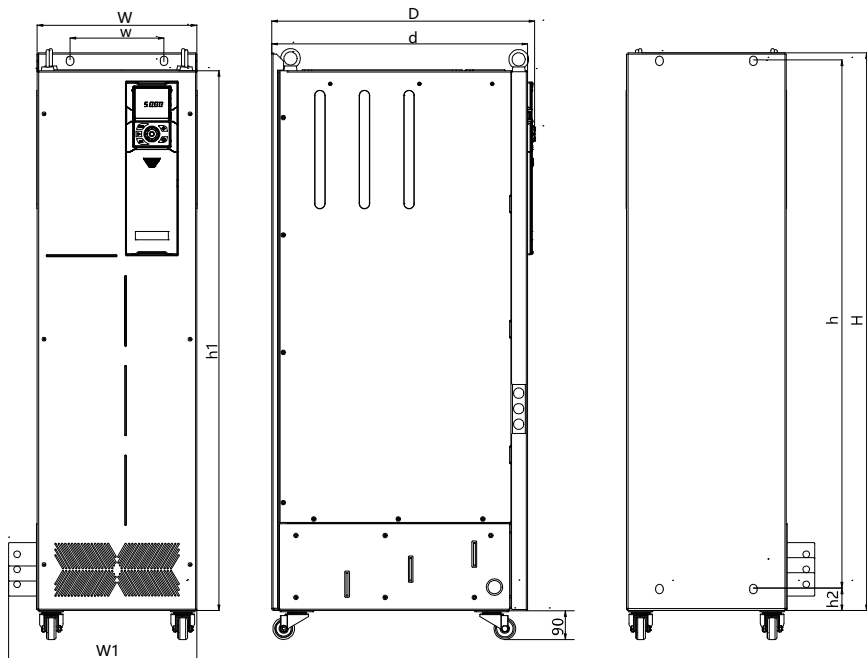


Fig. 3-4 Outside view D  
Table 3-2 Dimensions

Model XFC550-3P4-□	Dimensions (mm)											
	Outside view	W	H	D	w	h	h1	h2	d	W1	Set screw	Weight (kg)
185K	D	340	1218	560	200	1150	1180	53	545	400	M12	210
200K												
220K												
250K												
280K												
315K												
355K												
400K												
450K	340	1445	560	200	1375	1410	56	545	400	M12	245	

### 3.3 Mounting direction and space

#### 3.3.1 Mounting direction

Install the frequency converter in a vertical upward direction.

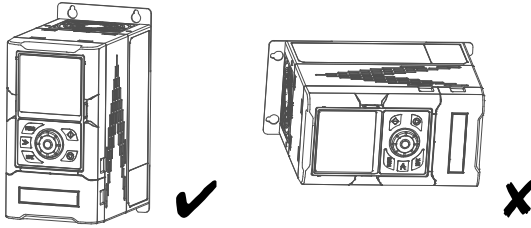


Fig. 3-5 Mounting direction

### 3.3.2 Mounting of single frequency converter

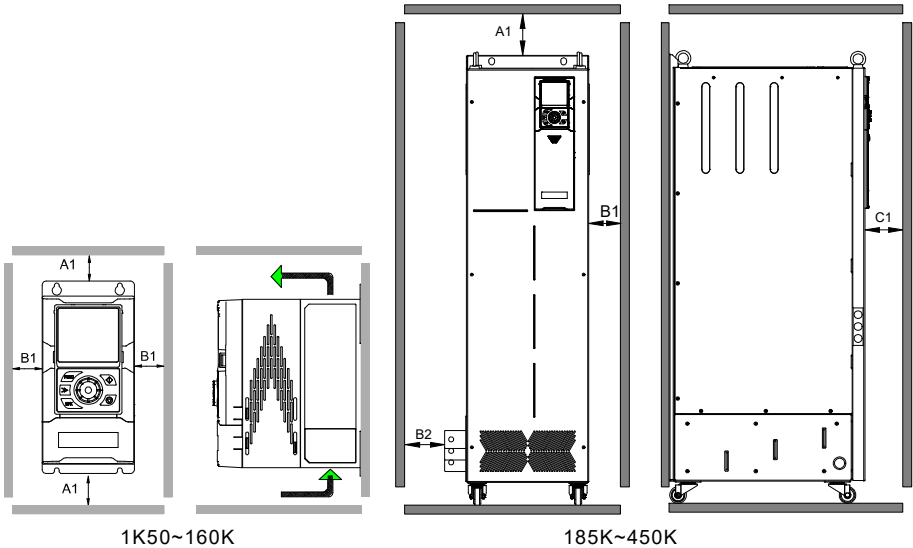


Fig. 3-6 Installation space (single machine)

In order to ensure the ventilation space and wiring space required for the frequency converter, the installation space should be reserved around the frequency converter. Be sure to follow the installation conditions shown in Table 3-3.

Table 3-3 Installation space and size (single machine)

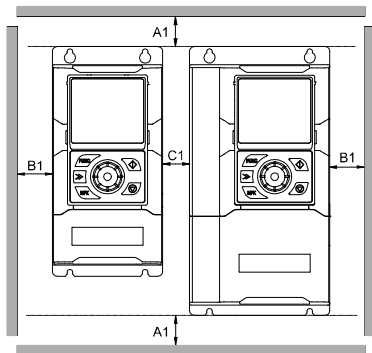
Model XFC550-3P4-□	Size (mm)			
1K50~15K0	A1 ≥ 150	B1 ≥ 10		
18K5~160K	A1 ≥ 150	B1 ≥ 30		
Model XFC550-3P4-□	Size (mm)			
185K~450K	A1 ≥ 250	B1 ≥ 10	B2 ≥ 20	C1 ≥ 20

### 3.3.3 Installation of multiple frequency converters in parallel

When the XFC550 series frequency converters dissipate heat, the heat is dissipated from bottom to top. When multiple frequency converters work at the same time, they are usually installed side by side. The upper part of the machine should be aligned, especially the frequency converters of different sizes, as shown in Figure 3-7.

### 3. Installation

When the frequency converter is installed in the cabinet, the verticality and space should be fully considered to facilitate heat dissipation. The installation dimensions are as specified in Table 3-4.

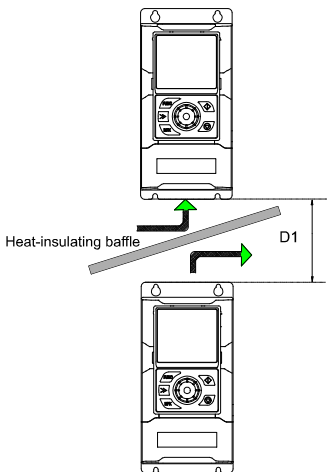


**Fig. 3-7 Installation space (multiple frequency converters in parallel)**

**Table 3-4 Installation space and size (multiple frequency converters in parallel)**

Model XFC550-3P4-□	Size (mm)		
1K50~15K0	$A1 \geq 150$	$B1 \geq 10$	$C1 \geq 10$
18K5~160K	$A1 \geq 150$	$B1 \geq 30$	$C1 \geq 10$

#### 3.3.4 Installation of top and down frequency converters



When the frequency converters need to be installed in top and down rows, the heat of the down row of frequency converters will cause the temperature of the top row of frequency converters to rise, which will cause overheating/overloading faults of the top row of frequency converters. Therefore, measures such as installing heat-insulating baffles should be taken, such as Figure 3-8 shows.

Note: Over 160K does not support top and down installation.

**Fig. 3-8 Installation space for frequency converter (top and down installation)**

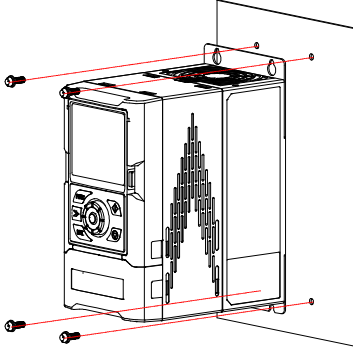
**Table 3-5 Installation space and size (top and down installation)**

Model XFC550-3P4-□	Size (mm)
1K50~15K0	$D1 \geq 300$
18K5~160K	$D1 \geq 400$

### 3.4 Wall-mounting and flush installation

The XFC550 series frequency converters have different installation methods depending on the power level. Please follow the installation instructions below for product installation in accordance with the specific model and installation requirements.

#### 3.4.1 Wall-mounting type



#### ATTENTION:

In this type of installation, fix the frequency converter with four screws as shown on the left picture. Otherwise, the fixed part of the frequency converter may fall off due to uneven force during long-term operation. Over 160K does not support wall-mounting installation.

Fig. 3-9 Wall-mounting type of frequency converter

#### 3.4.2 Embedded installation

##### Steps for plastic structure embedded installation(1K50-22K0)

1. Secure the left and right external brackets to the machine with screws.
2. The machine body passes through the mounting plate from the back.
3. Screw the body of the external bracket to the mounting plate with screws.

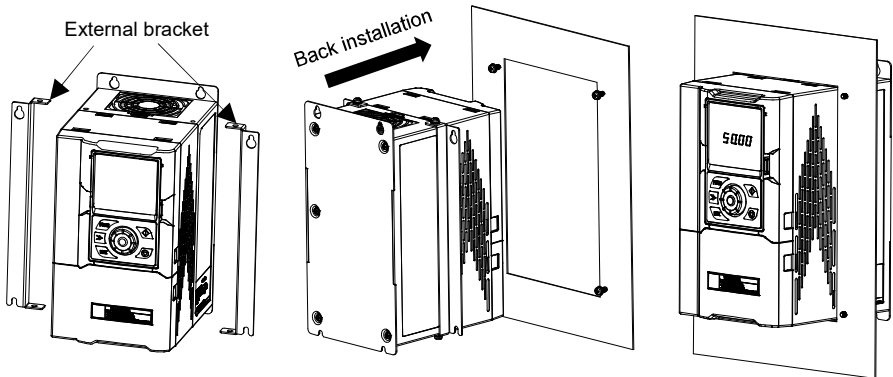
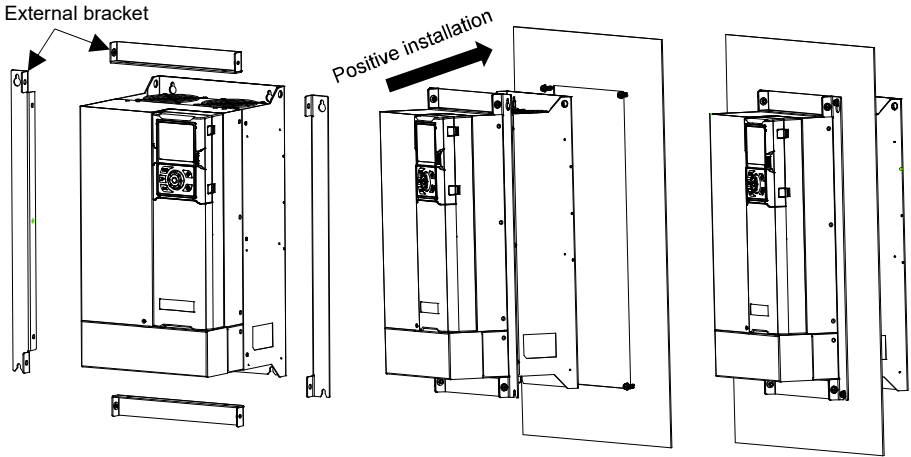


Fig. 3-10 Diagram of steps for plastic structure embedded installation

##### Steps for sheet metal structure embedded installation(30K0-160K)

1. Fix the upper, lower, left and right external brackets to the machine body with screws.
2. The machine body passes through the mounting plate from the front.
3. Screw the body of the external bracket to the mounting plate with screws.

### 3. Installation



**Fig. 3-11 Diagram of steps for sheet metal structure embedded installation**  
**Table 3-6 Table of accessories shape and assembly size for embedded installation**

Model XFC550-3P4-□	Installation plate's hole position and size (mm)				Set Screw	Fixing moment (N.m)	Diagram of embedded mounting plate size
	H1	W1	H2	W2			
1K50	204	114	186	136	M5	2	<p>The diagram shows a rectangular mounting plate with a central red crosshair. The width is labeled W1 and W2, and the height is labeled H1 and H2. The plate is shown being embedded into a larger structure.</p>
2K20							
4K00							
5K50							
7K50	244	144	226	166	M5	2	
11K0							
15K0							
18K5	324	194	306	216	M5	2	
22K0							
30K0	510	285	500	306	M6	4	
37K0							
45K0							
55K0	580	317	570	335	M8	8	
75K0							
90K0	666	372	654	408	M10	20	
110K							
132K							
160K	872	472	843	508	M10	20	

The embedded mounting bracket selection is commonly found in section 10.3.  
 Note: Over 160K does not support embedded installation.

### 3.5 Installation of operating panel

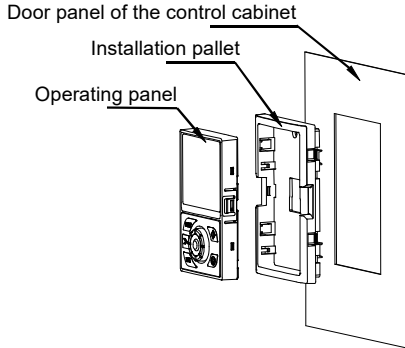


Fig. 3-12 Diagram of operating panel installed on the outside of the control cabinet

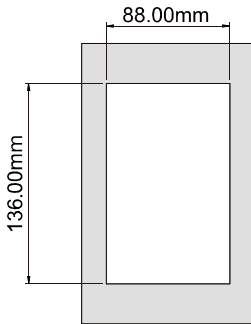


Fig. 3-13 Diagram of hole size of door panel

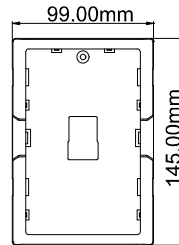


Fig. 3-14 Diagram of installation pallet

3

When the operating panel is installed on the outside of the control cabinet, it needs to process the door panel of the control cabinet, with the hole size as shown in Fig. 3-13.

The mounting pallet's model and size are uniform, its model is XFC5-PHO-00, and can be purchased with our company if necessary.

## 4. Wiring

### 4.1 Installation precautions and installation site requirements



#### DANGER

- ✓ To prevent electric shock, do not wire when the power is on, otherwise there is a risk of electric shock.



#### WARNING

- ✓ Do not operate with the frequency converter cover removed, otherwise there is a risk of electric shock.
- ✓ Be sure to ground the ground terminal on the motor side, otherwise it may cause electric shock or fire due to contact with the motor case.
- ✓ Do not wear loose clothing or accessories, and do not operate the frequency converter in the case without wearing eye protector.
- ✓ Tighten the terminal screws to the specified torque. If the connection of the main circuit wires is loose, it may cause a fire due to overheating at the wire connection.
- ✓ Do not allow inflammables to come into contact with the frequency converter or attach flammable materials to the frequency converter, otherwise there is a risk of fire.
- ✓ Do not use the wrong voltage for the main circuit power supply, otherwise there is a risk of fire.
- ✓ Before powering on, please confirm whether the rated voltage of the frequency converter is consistent with the power supply voltage.
- ✓ Please connect the brake resistor and brake unit according to the wiring diagram.

4

#### ATTENTION:

- ✓ Do not unplug the motor when the frequency converter is outputting voltage, otherwise the frequency converter will be damaged.
  - ✓ When wiring the control circuit, do not use cables other than shielded wires. Please use double stranded shielded wires and connect the shield to the ground terminal of the frequency converter for grounding.
  - ✓ Do not change the circuit of the frequency converter, otherwise the frequency converter will be damaged. The damage caused shall not be covered by the company.
  - ✓ After wiring the frequency converter and other machines, please confirm that all wiring is correct.
-



## 4.2 Standard wiring diagram

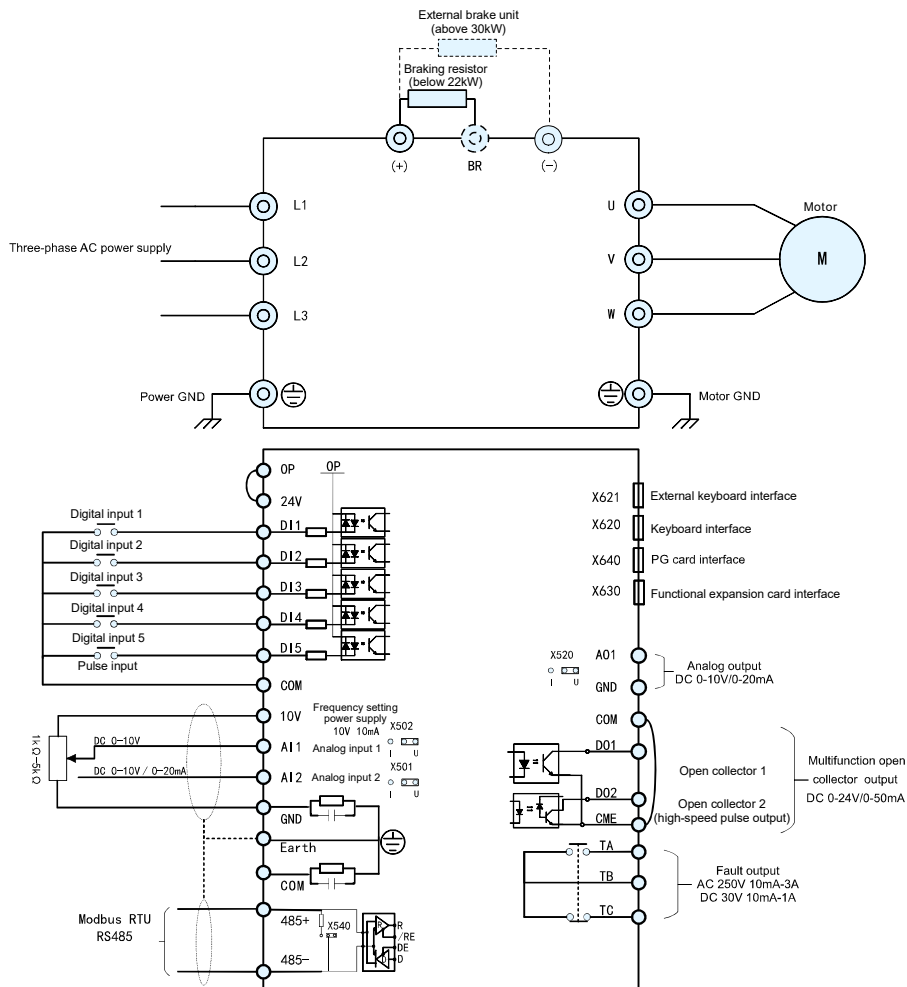


Fig. 4-1 Standard wiring diagram of frequency converter

## 4.3 Removal and installation of operating panel and cover plate

### ATTENTION:

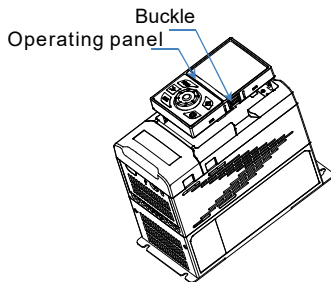
Do remember to power off the machine during the removal and installation process.

### 4.3.1 Removal and installation of operating panel

#### Removal

Put your fingers on the buckles on both sides of the operating panel and squeeze them in at the same time, and then lift them up slightly until the buckle of the operating panel is disengaged

from the case, that is, the operating panel is removed.



**Fig. 4-2 Removal of frequency converter's operating panel**

### Installation

Put the operating panel in the original position, press the buckles on both sides while pressing inward until you hear a click.

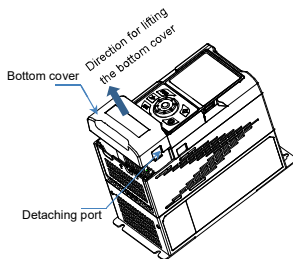
### 4.3.2 Removal and installation of bottom cover

XFC550 series frequency converters need to remove the bottom cover for main circuit and control circuit wiring.

#### Model of below 22K0

**Removal:** Put your fingers into the detaching ports on both sides of the bottom cover, and squeeze them on both sides with force, and lift them up slightly until the bottom cover is disengaged from the case, thus the bottom cover is removed.

**Installation:** Put the lower cover in the original position, press the buckles on both sides while pressing inward until you hear a click.



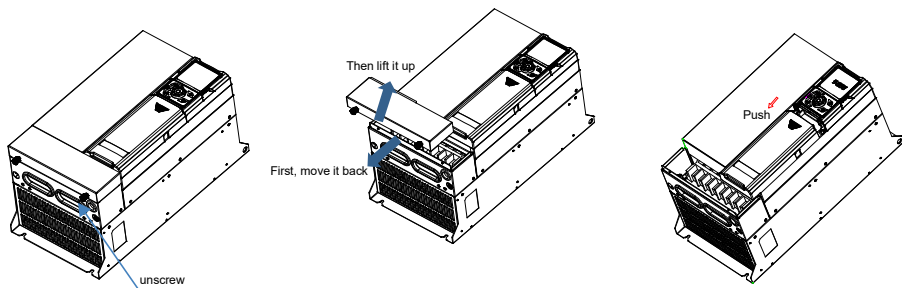
**Removal and installation of model below 22K0**

4

#### Model of above 30K0

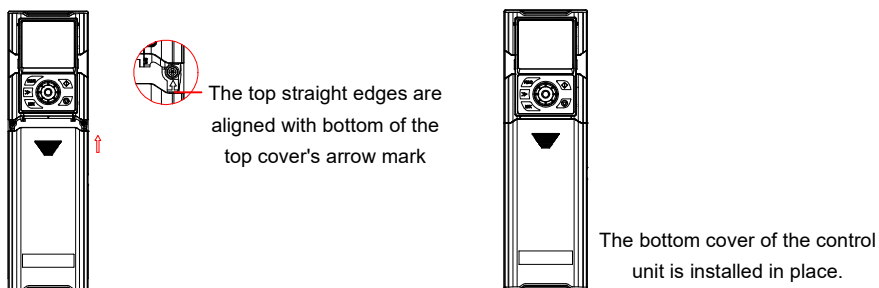
The bottom cover of the model above 30K0 is divided into two types: the sheet metal bottom cover and the control unit bottom cover.

**Removal:** The bottom cover of the control unit must be removed after the sheet-metal bottom cover is removed. The steps are as follows: 1. Unscrew the two captive screws at the bottom by hand; 2. Hold the bottom cover of the sheet metal with both hands, and move it backwards until the tongue of the sheet-metal bottom cover is retracted to the upper cover card slot. By lifting it up, you can remove the sheet-metal bottom cover; 3. Push the bottom cover of the control unit in the direction of the arrow to complete the disassembly.



### Removal of model of above 30K0

Installation: Place the bottom cover of the control unit in place (the straight edges on both sides of the top are aligned with the bottom of the control unit's upper cover arrow mark), then push the bottom cover of the control unit horizontally in the direction of the arrow, place the sheet metal bottom cover in the original place, and finally press captive screws and tighten them, thus the installation is completed.



### Installation of model of above 30K0

Fig. 4-3 Removal and installation of frequency converter's bottom cover

#### 4.3.3 Removal of wiring baffle

4

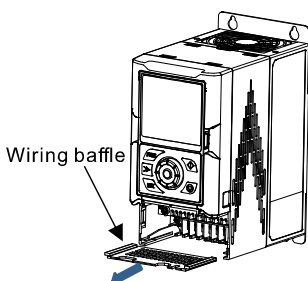


Fig. 4-4 Removal of frequency converter's wiring baffle

## 4.4 Main circuit

In order to safely and correctly wire the main circuit of the frequency converter, the main circuit will be described in detail below.

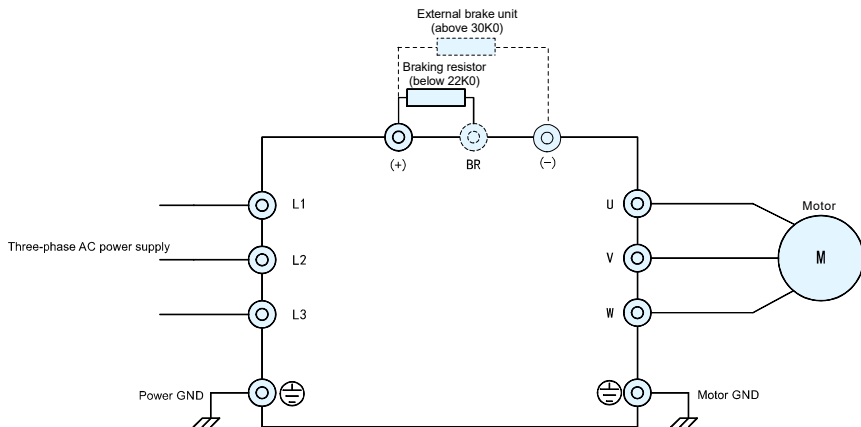


Fig. 4-5 Wiring diagram of main circuit

4.4.1 Functions of main circuit terminals

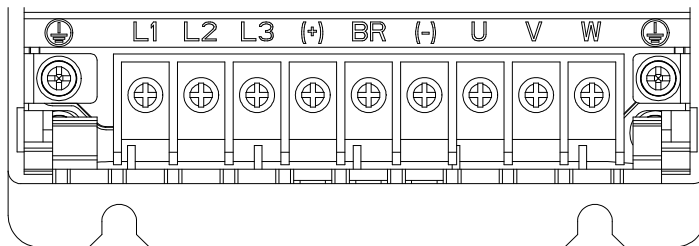


Fig. 4-6 Distribution diagram of main circuit terminal

Table 4-1 Functions of main circuit terminals

Terminal symbol	Description	Functions
L1	Power inputs of frequency converter	Input terminal of the frequency converter's main circuit power supply
L2		
L3		
(+)	DC bus (+)	To connect braking resistor or braking unit
BR	Braking resistor connection	To connect braking resistor (No BR terminal for above 30kW model)
(-)	DC bus (-)	To connect braking unit
U	Frequency converter outputs	Frequency converter's output terminal to connect motor
V		
W		
⊕	Earth	Input and Output Grounding of Frequency converter

4.4.2 Wire size and tightening torque for main circuit wiring

When wiring is conducted, select the wires used in the main circuit from Table 4-2.

**ATTENTION:**

Please take the voltage drop of the wire into consideration when selecting the wire size.

For main circuit wiring, please use terminals with insulated ends.

**Table 4-2 Size of main circuit wire and tightening torque**

Model XFC550-3P4-□	Fuse (A)	Recommended size of input/output power cable (mm <sup>2</sup> )	Size of GND cable (mm <sup>2</sup> )	Screw size	Tightening torque N·m/lbf·in
1K50	10	2.5	2.5	M3	0.8~1/7~8.78
2K20	10	2.5	2.5	M3	0.8~1/7~8.78
4K00	16	2.5	2.5	M4	1.2~1.5/10.6~13.3
5K50	20	4	4	M4	1.2~1.5/10.6~13.3
7K50	32	4	4	M4	1.2~1.5/10.6~13.3
11K0	40	6	6	M4	1.2~1.5/10.6~13.3
15K0	50	6	6	M4	1.2~1.5/10.6~13.3
18K5	80	10	10	M5	2~2.5/17.7~22.1
22K0	100	16	16	M5	2~2.5/17.7~22.1
30K0	100	16	16	M8	9~11/79.7~97.4
37K0	125	16	16	M8	9~11/79.7~97.4
45K0	150	25	16	M8	9~11/79.7~97.4
55K0	200	50	25	M8	9~11/79.7~97.4
75K0	250	70	35	M10	18~23/159~204
90K0	275	95	50	M10	18~23/159~204
110K	325	120	70	M10	18~23/159~204
132K	400	150	95	M10	18~23/159~204
160K	500	185	95	M10	18~23/159~204
185K	600	240	95	M12	32~40/283~354
200K	600	2*95	95	M12	32~40/283~354
220K	700	2*120	120	M12	32~40/283~354
250K	800	2*120	120	M12	32~40/283~354
280K	800	2*150	150	M12	32~40/283~354
315K	1000	2*185	185	M12	32~40/283~354
355K	1000	2*185	185	M12	32~40/283~354
400K	1400	2*240	240	M12	32~40/283~354
450K	1400	2*300	300	M12	32~40/283~354

### 4.4.3 Connection of the motor to the main circuit terminals

The procedures, precautions, and inspection points in wiring the main circuit terminals are explained below.

1. Connect the frequency converter's output terminals U, V, W to the input terminals U, V, W of the motor. In this case, be sure to match the phase sequence of the motor terminals to the frequency converter terminals. If the phase sequence is inconsistent, it will cause the motor to rotate in the opposite direction.

2. Do not connect the power supply to the output terminals of the frequency converter. Failure to do so may result in damage to the frequency converter or even a fire.

### 4.4.4 Wiring distance between the frequency converter and the motor

The length of the cable connected between the frequency converter and the motor is too long, and the large distributed capacitance is prone to generate high-order harmonic current. The user can select the cable length according to the specific working conditions. Make sure that the wiring distance is as short as possible or that the output reactor is configured at the same time.

### 4.4.5 Grounding mode

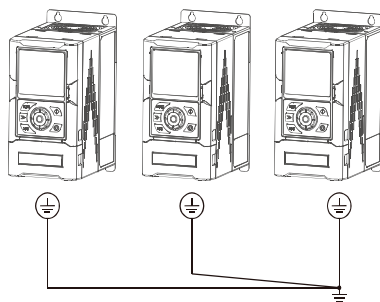
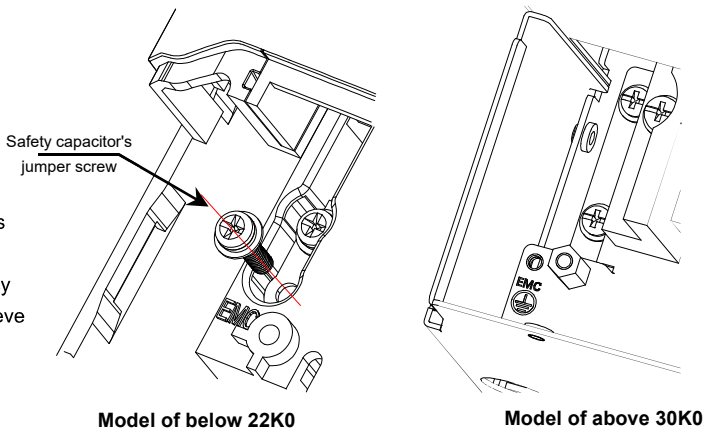


Fig. 4-7 Grounding mode

### 4.4.6 Power grid system requirements for main circuit connection




Note: When the EMC's connection screws are removed, the frequency converter will not achieve the nominal EMC performance.

Fig. 4-8 Requirements of power network system

This product is suitable for neutral grounded power grid systems. If used in an IT grid system (neutral ungrounded power grid system), the safety capacitor's (EMC) ground jumper screw need to be removed, as shown in the figure above. And the filter cannot be installed, otherwise, the product may be damaged. In the application with a leakage circuit breaker equipped, if there is a jump leakage during start-up, the safety capacitor's (EMC) jumper screw can be removed.

## 4.5 Control circuit

### 4.5.1 Functions of control circuit terminals

	<b>Warning</b>
<ul style="list-style-type: none"> <li>✓ Safety measures when the machine is restarted After the emergency stop circuit is wired, be sure to check if it works properly. In order to enable the frequency converter to perform the stop action safely and quickly, an emergency stop circuit needs to be set. Otherwise there is a risk of personal accidents.</li> <li>✓ Before the test run, please confirm the input and output signals of the frequency converter.</li> </ul>	

**Table 4-3 Functions of control circuit**

Category	Terminal symbol	Name of terminal	Description of function
Power supply	10V-GND	External+10V power supply	Supply+10V power to the outside Max output current:10mA Generally used as working power supply for external potentiometer. Potentiometer resistance range: 1kΩ-5kΩ
	24V-COM	External+24V power supply	Supply +24V power to the outside, generally used as working power supply for digital input and output terminals and external sensor. Maximum output current: 200mA
	OP	Digital input Common port of terminal	Connected to +24V by default. When driving DI1~DI5 with external power supply, the OP needs to be connected to the external power supply and disconnected from the +24V power supply terminal
Analog input	AI1-GND	Analog input terminal 1	1. Input range: DC0V-10V/4mA-20mA, the signal type is dependent on X502 jumper on the control board. 2. Input impedance: 22kΩ for voltage input and 500Ω for current input
	AI2-GND	Analog input terminal 2	1. Input range: DC0V-10V/4mA-20mA, the signal type is dependent on X501 jumper on the control board. 2. Input impedance: 22kΩ for voltage input and 500Ω for current input

#### 4. Wiring

Category	Terminal symbol	Name of terminal	Description of function
Digital input	D11-OP	Digital input 1	1. Optocoupler isolation, compatible with bipolar inputs 2. Input impedance: 2.4kΩ 3. Level input voltage range: 9V~30V
	D12-OP	Digital input 2	
	D13-OP	Digital input 3	
	D14-OP	Digital input 4	
	D15-OP	Digital input 5	In addition to the characteristics of D11~D14, it can also be used as a high-speed pulse input channel. Maximum input frequency: 100kHz
Analog output	AO1-GND	Analog output 1	The voltage or current output is determined by the X520 jumper selection on the control board. Output voltage range: 0V~10V (maximum output current: 5mA) Output current range: 0mA~20mA (maximum load resistance: 500Ω)
Digital output	DO1-CME	Digital output 1	Optocoupler isolation, bipolar open collector output Output voltage range: 0V-24V Output current range: 0mA-50mA Note: CME and COM have been externally shorted at the factory
	DO2-CME	Digital output 2 (high-speed pulse output)	The output mode is constrained by the functional code F2-00 "DO2 terminal output mode selection". When it is output as a high-speed pulse, the highest frequency reaches 100kHz. When it is output as open collector, it is the same as DO1.
Communication	485+ - 485-	RS485	Standard RS485 interface, Terminal resistance is plugged in or not is determined by the X540 jumper selection on the control board.
Relay output	TA-TB	Normally-open terminal	Contact drive capability: 250VAC, 3A, COSØ=0.4, 30VDC, 1A
	TB-TC	Normally-closed terminal	
Auxiliary interface	X630	Expansion card interface	22-pin terminal, interface between control board and optional card (I/O expansion card, programmable card, etc.)
	X640	PG card interface	16-pin terminal, optional single-ended, differential, resolver, etc. for coder interface
	X620/X621	Keyboard interface	Standard keyboard interface/remote keyboard interface



### 4.5.2 Wire size and tightening torque for control loop wiring

In order to ensure the reliability of the wiring, please select the wiring wire for the actual situation.

**Table 4-4 Wire size and tightening torque for control loop wiring**

Terminal block	Terminal symbol	Screw size	Tightening torque ( N.m)(LB-IN)	Wire dia. (mm <sup>2</sup> ) (AWG)
X602/ X603	10V/AI1/AI2/GND/DI1/DI2/DI3/DI4/ DI5/COM/485+/485-/GND/AO1/DO1/ DO2/CME/COM/OP/24V	M2	0.2 (1.7)	0.5-1.5 (28-16)
X601	TA/TB/TC	M2.5	0.4 (3.5)	2.5 (28-12)

### 4.5.3 Wiring for control circuit terminal block

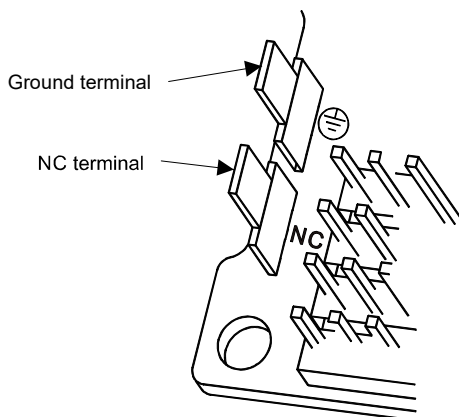
Steps for wiring control circuit

1. Processing of the end of the wire. After removing the protective layer of the wire, use the finger to gently rub the core wire or the crimping bar terminal in order to prevent the core wire from spreading;
2. Loosen the screw and insert the wire. Connect wire in the order of X602, X603, and X601.

### 4.5.4 Control circuit grounding

Connect the ground wire of the control board to the ground terminal under the condition that the frequency converter and the system are reliably grounded. Otherwise, connect the frequency converter to the NC terminal to avoid interference with the control board.

The ground terminal and NC terminal position are as shown in the figure below:



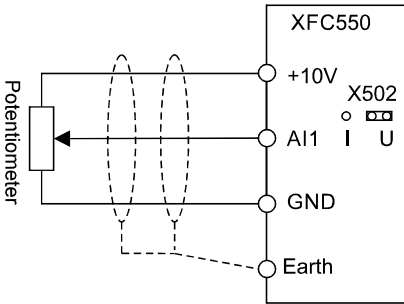
**Fig. 4-9 Diagram of control board's ground terminal and NC terminal's position**

## 4.6 Connection of input/output signals

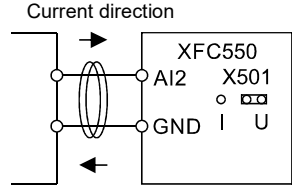
### 4.6.1 Analog input terminals AI1 and AI2

The weak current analog input signal is susceptible to external interference. Therefore, it is generally necessary to use a shielded cable, and make the wiring distance as short as possible. When the signal is seriously disturbed, a filter capacitor or a ferrite core should be added to the analog signal source.

Both AI1 and AI2 can be input with voltage signal and current signal. The schematic diagram is as follows:



Voltage signal input



Current signal input

Fig. 4-10 Wiring diagram of analog input terminal

The shield of the analog terminal should be led out of the shield on the frequency converter side and connected to the PE.

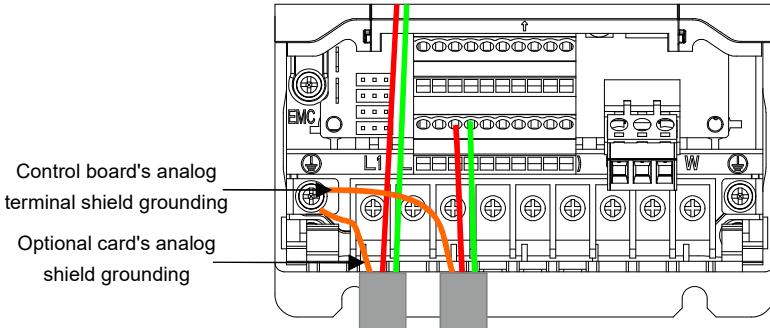


Fig. 4-11 Diagram of the shield grounding of the 1K50/2K20 analog terminal

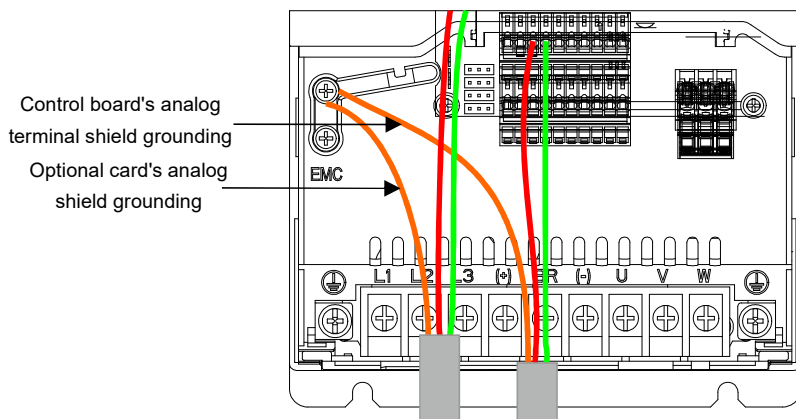


Fig. 4-12 Diagram of the shield grounding of the 4K00/5K50/7K50 analog terminal

#### 4.6.2 DI terminal

##### Leakage wiring mode

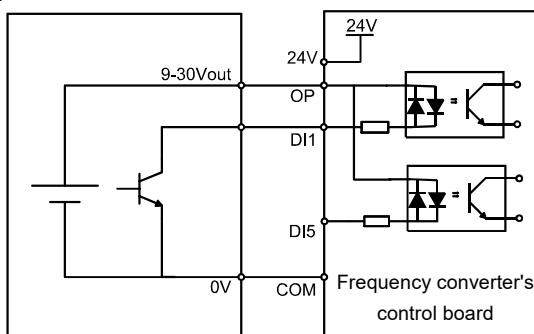


Fig. 4-13 Diagram of external power supply for leakage wiring mode

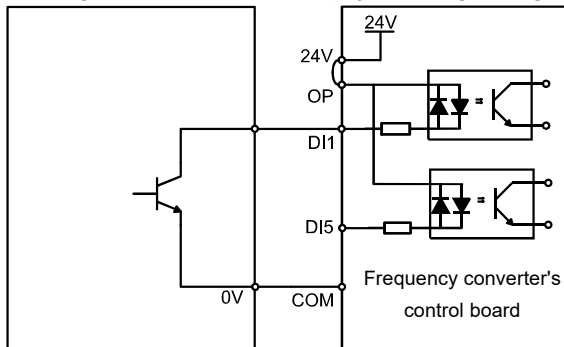


Fig. 4-14 Diagram of internal power supply for leakage wiring mode

Source wiring mode

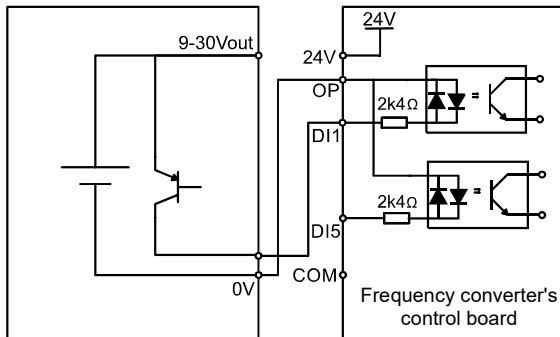


Fig. 4-15 Diagram of external power supply for source wiring mode

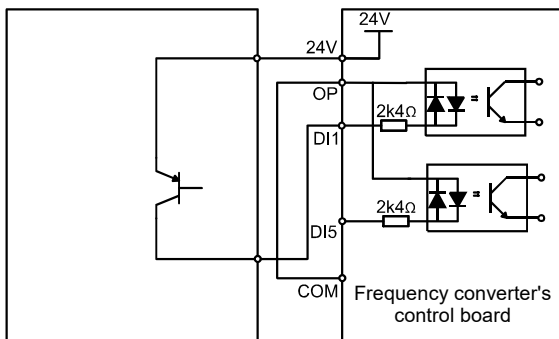


Fig. 4-16 Diagram of internal power supply for source wiring mode

4

4.6.3 DO terminal

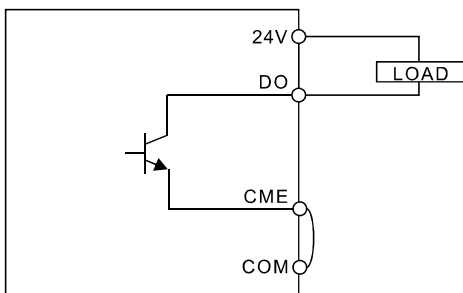
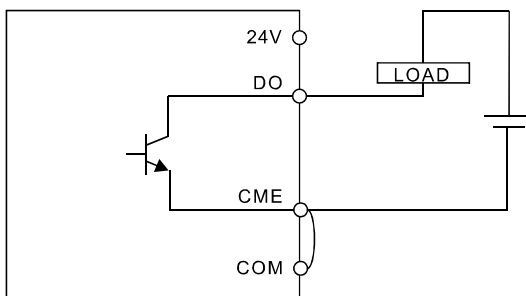


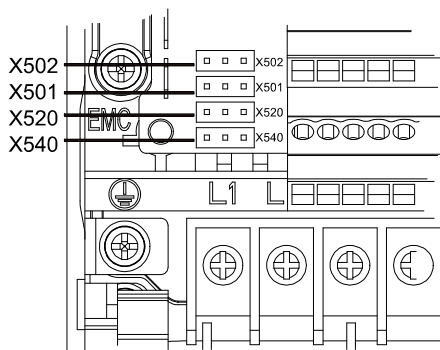
Fig. 4-17 Diagram of internal power supply wiring for digital output terminal



The digital output CME must be shorted to COM for normal use. When external power supply is adopted, the external power reference ground needs to be connected to COM.

**Fig. 4-18 Diagram of external power supply wiring for digital output terminal**

Note 1: The position of X502\X501 \X520\X540 appearing in the manual on the control board is as shown below:



**Fig. 4-19 The position of X502\X501\X520\X540**

# 5. Operation

## 5.1 Safety precautions

**DANGER**

- ✓ The frequency converter can be powered only after the housing is installed. It is forbidden to remove the housing after power-on.
- ✓ Before starting the motor and mechanical equipment, be sure to confirm that the motor and mechanical equipment are working within the permissible range.

**WARNING**

- ✓ It is forbidden to check and measure the signal during the running of the frequency converter.
- ✓ Do not change the parameter settings at will.
- ✓ Before switching the frequency converter running command channel, be sure to switch the debugging first.
- ✓ Do not touch the energy consumption braking resistor because it is very hot and easy to burn.

## 5.2 Description of operating panel

### 5.2.1 Components of operating panel and functions

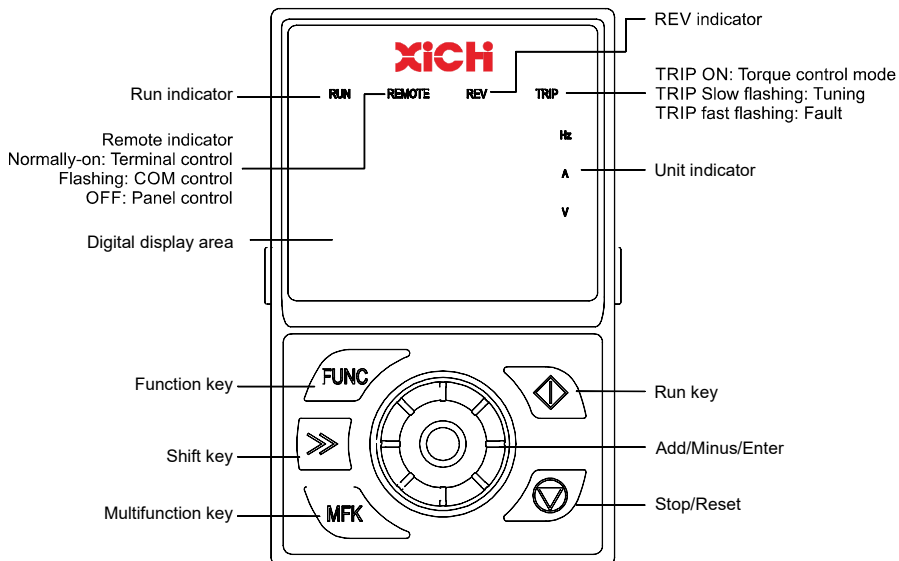








Fig. 5-1 Components of operating panel and functions

Table 5-1 Components of operating panel and functions

Symbol	Buttons	Function
	Function button	<ol style="list-style-type: none"> <li>1. Enter the level 1 menu from level 0 menu</li> <li>2. Go back to the level 1 menu</li> <li>3. Function code parameter abandons save and return</li> </ol>
	Add (rotate clockwise)	<ol style="list-style-type: none"> <li>1. Function code increases at level 1 or 2 menu</li> <li>2. Data increases at level 3 menu</li> <li>3. Frequency increases by set value in stop/run status</li> </ol>
	Minus (rotate anticlockwise)	<ol style="list-style-type: none"> <li>1. Function code decreases at level 1 or 2 menu</li> <li>2. Data decreases at level 3 menu</li> <li>3. Frequency decreases by set value in stop/run status</li> </ol>
	Enter (Press)	Enter the menu interface step by step and enter the parameters
	Shift	<ol style="list-style-type: none"> <li>1. Use &gt;&gt; to shift menu edit bit at level 2 menu</li> <li>2. Use &gt;&gt; to shift menu edit bit at level 3 menu</li> <li>3. Switch the parameters such as frequency, current and voltage displayed operating panel during stop/run</li> </ol>
	Run	Used for start control of frequency converter when operation command is reference on operating panel
	Stop/Reset	<ol style="list-style-type: none"> <li>1. Used for stop control of frequency converter when operation command is reference on operating panel</li> <li>2. When fails and stops, it is used as a reset button to clear the fault prompt.</li> </ol>
	Multifunction	<ol style="list-style-type: none"> <li>1. Switching of FWD and REV</li> <li>2. FWD jogging</li> <li>3. REV jogging</li> <li>4. Switching between operating panel command channel and remote channel</li> <li>5. Switching of modified parameter list</li> </ol>

### 5.2.2 Correspondence table of number and characters

The numbers and characters displayed on the operating panel are shown in the following table:

**Table 5-2 Number and characters of operating panel**

Expected display characters	Actual characters	Expected display characters	Actual characters
0	0	L	L
1	1	n	n
2	2	r	r
3	3	U	U
4	4	y	y
5	5	G	G
6	6	h	h
7	7	l	l
8	8	N	N
9	9	o	o
A	A	q	q
b	b	T	T
C	C	t	t
d	d	u	u
E	E	c	c
F	F	H	H
P	P		



### 5.2.3 Description of LED indicators

Table 5-3 Description of LED indicators

Indicator	Description of function
RUN	When the indicator lights on, it indicates that the frequency converter is in running state, when the indicator goes off, it indicates that the frequency converter is in the stop state.
REMOTE	REMOTE OFF: Panel start/stop control method REMOTE Normally ON: Terminal start/stop control method REMOTE FLASHING: Comm. start/stop control method
REV	REV OFF: Forward rotation REV ON: Reverse rotation
TRIP	TRIP ON: Torque control mode TRIP SLOW FLASHING: Tuning control mode TRIP FASH FLASHING: Faulty state
Hz-A-V	Hz ON: Frequency unit A ON: Current unit V ON: Voltage unit Hz and A ON: rpm A and V ON: %

### 5.2.4 Hierarchy of operating panel's display function

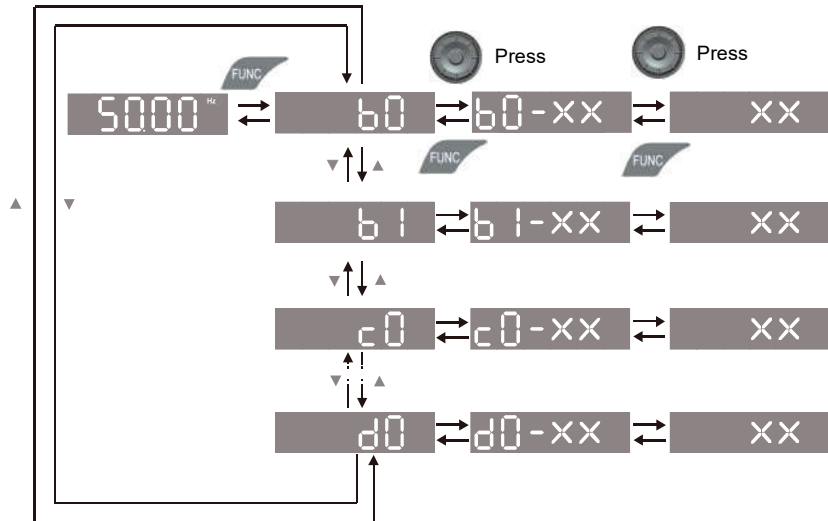


Fig. 5-2 Hierarchy of operating panel's display function

### 5.2.5 Frequency command setting

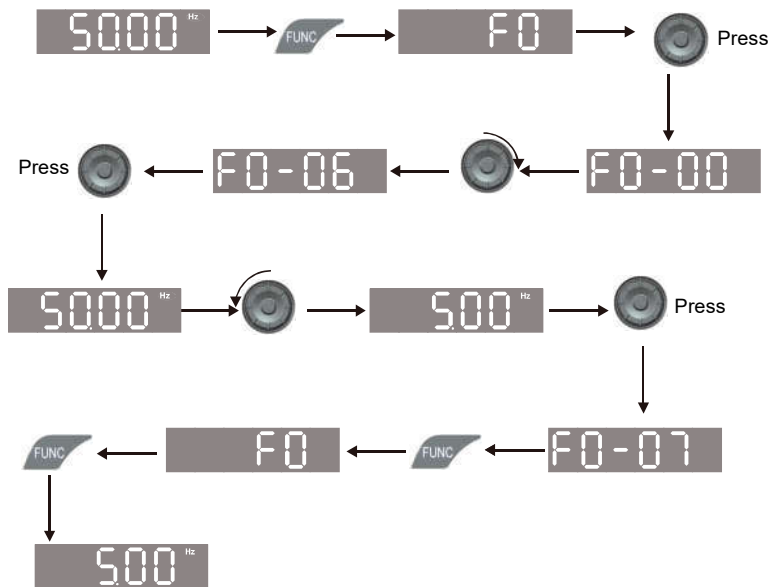
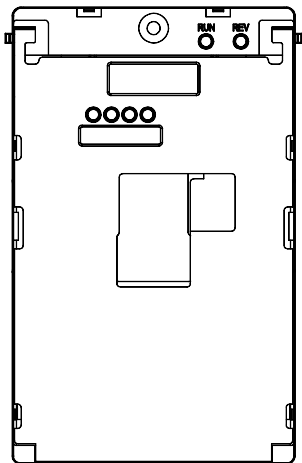


Fig. 5-3 Example for frequency command setting

### 5.3 Control board's indicator

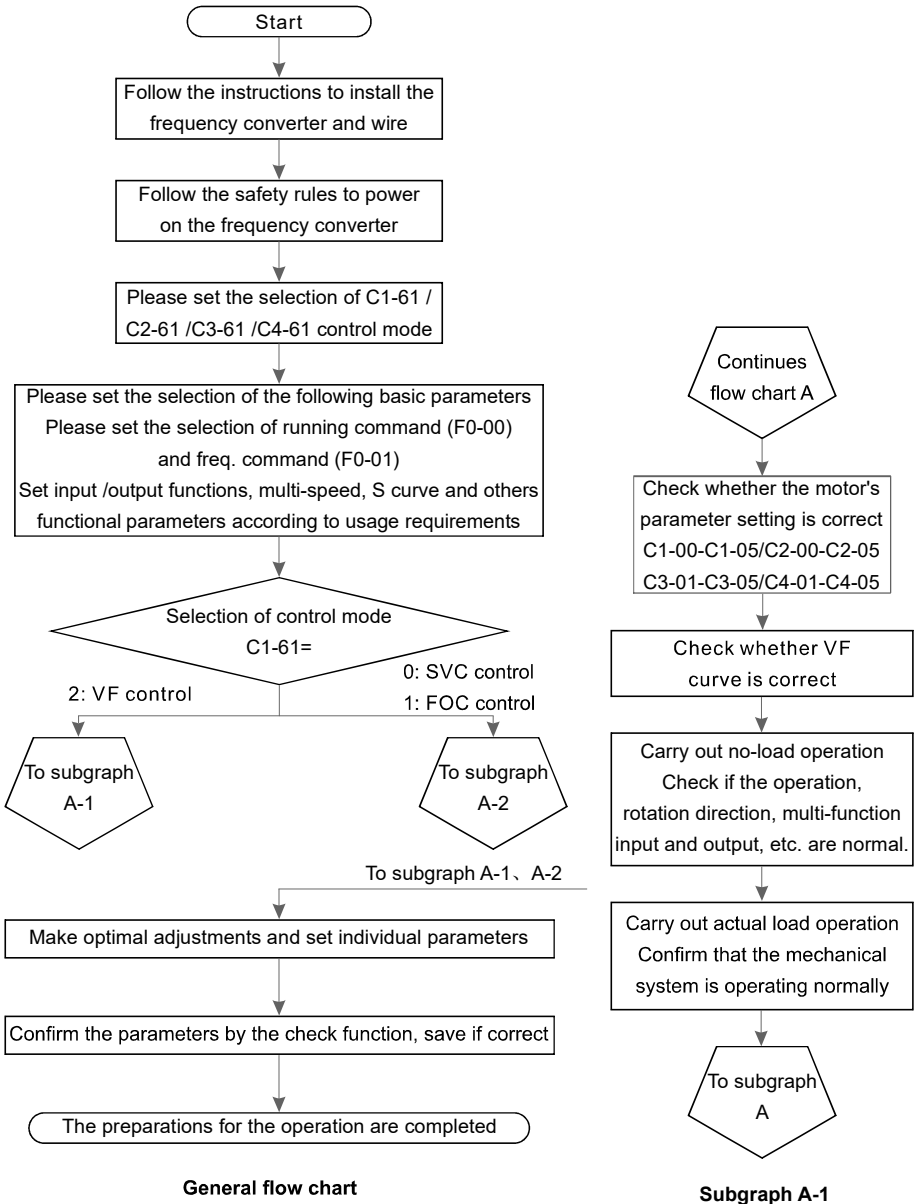


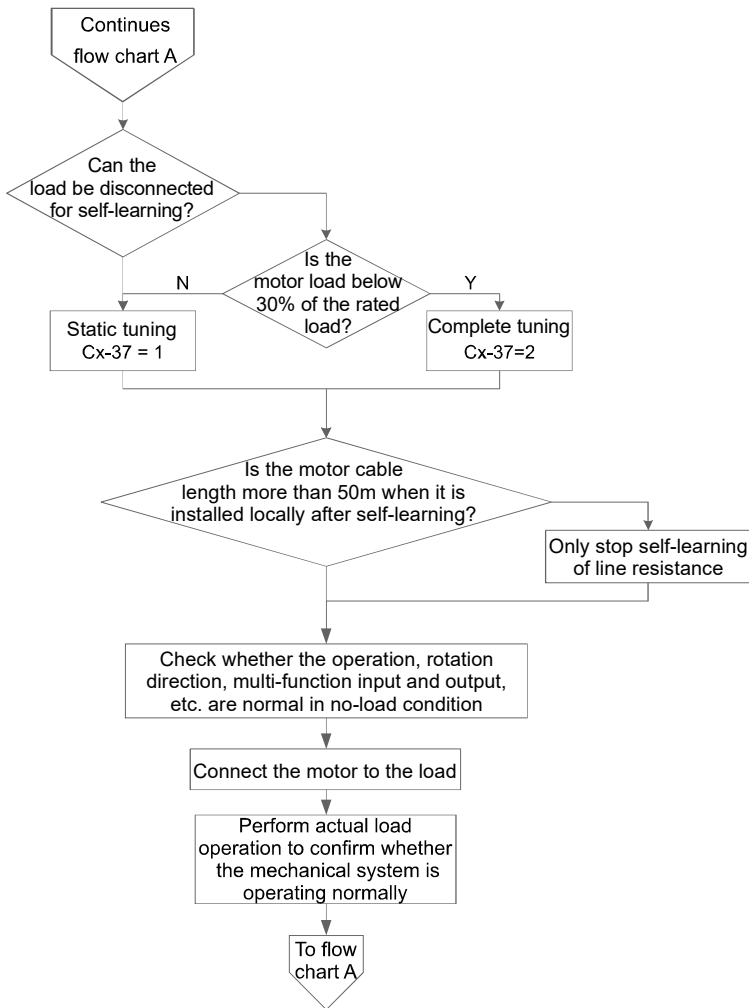
Indicator		Function
LED1	RUN	Light ON: Run
		Light OFF: Stop
		Slow flashing: Tuning
LED2	REV	Fast flashing: Fault
		OFF: Forward
		ON: Reverse

Fig. 5-4 Control board's indicator

5

## 5.4 Operating steps before running the frequency converter





Subgraph A-2

Fig. 5-5 Basic steps before operation

## 5.5 Confirmation of power on and display state

### 5.5.1 Power on

Items:

1. Confirmation of the power supply voltage. Please confirm that the power supply voltage is correct.

200V: Three phase AC200V~240V 50/60Hz

400V: Three phase AC380V~ 480V 50/60Hz

Please connect the power input terminals L1, L2, and L3 reliably. Confirm that the frequency converter and motor are properly grounded.

2. Confirmation of connection between frequency converter's output terminal and motor's terminal.

Confirm that the connection between the frequency converter output terminals (U, V, W) and the motor terminals (U, V, W) is secure.

3. Connection confirmation of the frequency converter's control circuit terminal.

Confirm that the connection between the control circuit terminals of the frequency converter and other control devices is secure.

4. Confirmation of the status of the frequency converter's control terminals.

Confirm if the frequency converter's control circuit terminals are all in the OFF state (the frequency converter is not running)

5. Confirmation of load status.

Check if the motor is in the no-load state (the state not connected to the mechanical system).

## 5.5.2 Display state

**Table 5-4 Confirmation of display state**

NO	Content
Normal	The data display will show the monitoring status of the frequency command
Faulty	The display result varies depending on the fault. Please refer to "Troubleshooting and measures" and take appropriate measures. TRIP light flashes quickly

## 5.6 Test run

### 5.6.1 Test run under no-load condition

Precautions before running:

1. Please confirm the safety around the motor and machinery.

2. Please confirm whether the emergency stop circuit and the mechanical safety device operate normally



Items need to be confirmed during running:



1. Does the motor rotate smoothly?

2. Are the acceleration and deceleration of the motor smooth?

Steps for run

**Table 5-5 Operating steps for test run without load**

Operating steps	LED display
1 The initial image is displayed after power-on	
2 Select function code F0-06, set running frequency to 5Hz	

Operating steps		LED display
3	Press the RUN button on the operation panel, the RUN indicator lights up, and the motor rotates forward at 5 Hz	
4	Confirm that the motor rotates in the correct direction and the frequency converter has no fault display	
5	If there is no fault in step 4, modify F0-06 to increase the frequency command value. When changing the set value, it is necessary to confirm the responsiveness and change it in units of 10 Hz. For each increase of set value, please confirm the output current (d0-04) through the manipulator to ensure that the current does not exceed the rated current of the motor. For example: 5Hz→50 Hz	
6	After confirming, press STOP to stop running. The RUN indicator goes off after it is completely stopped.	

### 5.6.2 Test run with load

After confirming the operation in the no-load state, connect the motor to the mechanical system for test run.

#### Precautions when connected to the mechanical system:

1. Please confirm the safety around the motor and machinery.
2. Please confirm that the motor is completely stopped.
3. Please connect the mechanical system.
4. Please confirm that the mounting screws are tight, and connect the motor shaft to mechanical system firmly.
5. Please confirm that the emergency stop circuit and the mechanical safety device operate correctly.
6. To prevent abnormal operation, please be prepared to press the stop button at any time.

#### Confirmation during running

1. Does the machine work in correct direction? (Is the direction of rotation of the motor correct?)
2. Are the acceleration and deceleration of the motor smooth?

#### Steps for running

1. After connecting the mechanical system to the motor, perform the test run in the same operation as the no-load operation.
2. Check if d0-04 (output current) is too large?
3. Change the frequency command and direction of rotation to confirm if there is abnormal sound and vibration?
4. If a control failure such as an offset or vibration occurs, handle it.

## 6. Functional parameter list

### 6.1 Description of parameter's access authority

Function code	Item	Setting range	Factory default	Change
b0-00	Access authority settings	0: Basic parameters 1: Standard parameters 2: Advanced parameters 3: Start parameters	0	☆

#### 0: Basic parameters

Only access to b0 basic system parameters, C0 power control parameters, d0 monitoring parameters, F0 control and setting parameters, P0 general keyboard parameters, and P1 LED keyboard parameters.

#### 1: Standard parameters

Only access to b0 basic system parameters, C0 power control parameters, C1 first motor parameters, C2 the second motor parameters, C3 the third motor parameters, C4 the fourth motor parameters, C5 V/f control parameters, C6 vector control parameters, d0 monitoring parameters, F0 control and setting parameters, F6 extended function parameters, F7 communication parameters, P0 general keyboard parameters, and P1 LED keyboard parameters.

#### 2: Advanced parameters

Only access to b0 basic system parameters, C0 power control parameters, C1 the first motor parameters, C2 the second motor parameters, C3 the third motor parameters, C4 the fourth motor parameters, C5 V/f control parameters, C6 vector control parameters, d0 monitoring parameters, F0 control and setting parameters, F1 input terminal parameters, F2 output terminal parameters, F3 AIAO correction, F4 multi-speed and simple PLC parameters, F5 PID control parameters, F6 extended function parameters, F7 standard communication parameters, F8 protection and fault parameters, P0 general keyboard parameters, P1 LED keyboard parameters, A0 swing frequency, fixed length and counting parameters, A2 virtual IO, U0 user programmable card parameters.

#### 3: Startup parameters

Only access to C0, C1, C5, group F0 (see the Quick Start Parameters Table).

6

### 6.2 Quick Start Parameters Table

The symbols in the parameter table are described as follows:

“☆” indicates that the set value of this parameter can be changed while the frequency converter is in the stop and running state;

“★” indicates that the set value of this parameter cannot be changed while the frequency converter is running;

“●” indicates that the value of this parameter is the actual detected record value and cannot be changed.

**Table 6-1 Quick Start Parameters Table**

Function code	Item	Setting range	Factory default	Change
C0-03	Carrier frequency	0.5kHz ~ 16.0kHz	Dependent on model	☆
C0-04	Carrier frequency adjusted along with temperature	0: NO 1: YES	1	☆
C1-01	Motor's rated power	0.1kW ~ 1000.0kW	Dependent on model	★
C1-02	Motor's rated voltage	1V ~ 2000V	Dependent on model	★
C1-03	Motor's rated current	0.01A ~ 655.35A(frequency converter's power <=55kW) 0.1A ~ 6553.5A(frequency converter's power >55kW)	Dependent on model	★
C1-04	Motor's rated frequency	0.01Hz ~ max frequency	Dependent on model	★
C1-05	Motor's rated speed	1rpm ~ 65535rpm	Dependent on model	★
C5-00	VF curve setting	0: straight line V/F 1: multipoint V/F 2: square V/F 3: 1.2nd power V/F 4: 1.4th power V/F 6: 1.6th power V/F 8: 1.8th power V/F 10: VF complete separation mode 11: VF semi-separation mode	0	★
F0-01	Main frequency source X selection	0: Digital setting(preset freq. F0-06, UP/DOWN modifiable, no memory when power off) 1: Digital setting(preset freq. F0-06, UP/DOWN modifiable, memory when power off) 2: AI1 3: AI2 4: AI3 5: PULSE setting 6: Multistage command 7: Simple PLC 8: PID 9: Communication setting	1	★
F0-07	Max frequency	50.00Hz ~ 500.00Hz	50.00Hz	★
F0-09	Upper limit frequency	Lower limit frequency F0-11 ~ max frequency F0-07	50.00Hz	☆
F0-11	Lower limit frequency	0.00Hz ~ upper limit frequency F0-09	0.00Hz	☆



Function code	Item	Setting range	Factory default	Change
F0-16	Frequency command during running UP/DOWN reference	0: Running frequency 1: Set frequency	0	★
F0-21	Running direction	0: Same direction 1: Opposite direction	0	☆
F0-26	Start mode	0: Direct start 1: Speed tracking restart 2: Pre-excitated start (AC asynchronous)	0	☆
F0-32	Stop mode	0: Deceleration stop 1: Free stop 2: Positioning stop	0	☆
F0-39	Acceleration time 1	0.00s ~ 650.00s (F0-37=2) 0.0s ~ 6500.0s (F0-37=1) 0s ~ 65000s (F0-37=0)	Dependent on model	☆
F0-40	Deceleration time 1	Same as F0-39	Dependent on model	☆
F0-41	Acceleration time 2	0.0s ~ 6500.0s	Dependent on model	☆
F0-42	Deceleration time 2	0.0s ~ 6500.0s	Dependent on model	☆
F0-43	Acceleration time 3	0.0s ~ 6500.0s	Dependent on model	☆
F0-44	Deceleration time 3	0.0s ~ 6500.0s	Dependent on model	☆
F0-45	Acceleration time 4	0.0s ~ 6500.0s	Dependent on model	☆
F0-46	Deceleration time 4	0.0s ~ 6500.0s	Dependent on model	☆
F0-47	Acceleration-deceleration mode	0: Linear acceleration and deceleration 1: S curve acceleration and deceleration A 2: S curve acceleration and deceleration B	0	★

### 6.3 Parameters list of function code

#### Group b: System parameters

Function code	Item	Setting range	Factory default	Change
<b>b0: Basic system parameters</b>				
b0-00	Access authority setting	0: Basic parameters 1: Standard parameters 2: Advanced parameters 3: Start parameters	0	☆

6. Functional parameter list

Function code	Item	Setting range	Factory default	Change
b0-01	Parameter initialization	0: No operation 1: Restore factory parameter, excluding motor's parameter 2: Clear records	0	★
b0-03	Function code's modification property	0: Modifiable 1: Non-modifiable	0	☆
b0-04	Parameter copy	0: InEffective 1: Back up parameters to the operating panel 2: Copy parameters from the operating panel	0	★
b0-05	User's password	0 ~ 65535	0	☆
b0-06	Total power-on hours	0h ~ 65535h	-	●
b0-07	Total power consumption	0kW ~ 65535 kWh of electricity	-	●
b0-08	Total running hours	0h ~ 65535h	-	●
b0-09	Product number	-	-	●
b0-10	Software version	-	-	●

**Group C: Power control parameters**

Function code	Item	Setting range	Factory default	Change
<b>C0: Power control parameters</b>				
C0-00	Reserved			
C0-01	Selection of motor	0: Motor 1 1: Motor 2 2: Motor 3 3: Motor 4	0	★
C0-02	SVC optimal mode selection	0: No optimization 1: Optimal mode 1 2: Optimal mode 2	1	☆
C0-03	Carrier frequency	0.5kHz ~ 16.0kHz	Dependent on model	☆
C0-04	Carrier frequency adjusted along with temperature	0: No 1: Yes	1	☆
C0-05	DPWM switches upper limit frequency	0.00Hz ~ 15.00Hz	12.00Hz	☆
C0-06	PWM modulation mode	0: Asynchronous 1: Synchronous	0	☆
C0-07	Random PWM depth	0: Random PWM inEffective 1 ~ 10: PWM carrier freq. random depth	0	☆
C0-08	Fast current limit enable	0: Disenable 1: Enable	1	☆
C0-09	Current detection compensation	0 ~ 100	5	☆

Function code	Item	Setting range	Factory default	Change
C0-10	Undervoltage point setting	60.0% ~ 140.0%	100.00%	☆
C0-11	Cooling fan control	0: Fan works during running 1: Fan always works	0	☆
C0-12	Selection of dead zone compensation mode	0: No compensation 1: Compensation mode 1 2: Compensation mode 2	1	☆
C0-13	Dead zone time adjustment	100% ~ 200%	150%	★
C0-14	Overvoltage	200.0~2500.0V	Dependent on model	★
C0-15	Motor overload warning coefficient	50% ~ 100%	80%	☆
C0-16	Type of motor's temperature sensor	0: No temperature sensor 1: PT100 2: PT1000	0	☆
<b>C1: The 1st motor's parameters</b>				
C1-00	Motor type selection	0: Common asynchronous motor 1: Variable frequency asynchronous motor	0	★
C1-01	Motor's rated power	0.1kW ~ 1000.0kW	Dependent on model	★
C1-02	Motor's rated voltage	1V ~ 2000V	Dependent on model	★
C1-03	Motor's rated current	0.01A ~ 655.35A (power of frequency converter<=55kW) 0.1A ~ 6553.5A (power of frequency converter >55kW)	Dependent on model	★
C1-04	Motor's rated frequency	0.01Hz ~ max frequency	Dependent on model	★
C1-05	Motor's rated speed	1rpm ~ 65535rpm	Dependent on model	★
C1-06	Asynch motor's stator resistance	0.001Ω ~ 65.535Ω (power of frequency converter<=55kW) 0.0001Ω ~ 6.5535Ω (power of frequency converter >55kW)	Tuning parameter	★
C1-07	Asynch motor's rotor resistance	0.001Ω ~ 65.535Ω (power of frequency converter<=55kW) 0.0001Ω ~ 6.5535Ω (power of frequency converter >55kW)	Tuning parameter	★
C1-08	Leakage reactance of asynch motor	0.01mH ~ 655.35mH (power of frequency converter<=55kW) 0.001mH ~ 65.535mH (power of frequency converter >55kW)	Tuning parameter	★

6. Functional parameter list

Function code	Item	Setting range	Factory default	Change
C1-09	Mutual inductive reactance of asynch motor	0.1mH ~ 6553.5mH (power of frequency converter<=55kW) 0.01mH ~ 655.35mH (power of frequency converter>=55kW)	Tuning parameter	★
C1-10	No-load current of asynch motor	0.01A ~ C1-03 (power of frequency converter<=55kW) 0.1A ~ C1-03 (power of frequency converter>=55kW)	Tuning parameter	★
C1-16	Reserved			
C1-17	Reserved			
C1-18	Reserved			
C1-19	Reserved			
C1-20	Reserved			
C1-21	Reserved			
C1-27	Encoder lines	1 ~ 65535	1024	★
C1-28	Encoder type	0:ABZ incremental encoder 1: UVW incremental encoder 2: Rotary transformer 3: Sine and cosine encoder 4: Line-saving UVW encoder	0	★
C1-29	Reserved			
C1-30	A/B phase sequence of ABZ encoder	0: Forward 1: Reverse	0	★
C1-31	UVW encoder's mounting angle	0.0 ~ 359.9°	0.0°	★
C1-32	UVW phase sequence of ABZ encoder	0: Forward 1: Reverse	0	★
C1-33	UVW encoder's offset angle	0.0 ~ 359.9°	0.0°	★
C1-34	Number of pole pairs of resolver	1 ~ 65535	1	★
C1-35	Reserved			
C1-36	Speed feedback PG broken line detecting time	0.0: No action 0.1s~10.0s	0.0	★
C1-37	Tuning selection	0: No operation 1: Static tuning of asynchronous motor 2: Complete tuning of asynchronous motor	0	★
C1-38	Speed loop proportional gain 1	1 ~ 100	30	☆
C1-39	Speed loop integral time 1	0.01s ~ 10.00s	0.50s	☆
C1-40	Switchover frequency 1	0.00 ~ C1-43	5.00Hz	☆
C1-41	Speed loop proportional gain 2	1 ~ 100	20	☆

Function code	Item	Setting range	Factory default	Change
C1-42	Speed loop integral time 2	0.01s ~ 10.00s	1.00s	☆
C1-43	Switchover frequency 2	C1-40 ~ max frequency	10.00Hz	☆
C1-44	Vector control slip gain	50% ~ 200%	100%	☆
C1-45	Speed loop filter time constant	0.000s ~ 0.100s	0.000s	☆
C1-46	Vector control overexcitation gain	0 ~ 200	64	☆
C1-47	Torque's upper limit source in speed control mode	0: Function code C1-48 setting 1: AI1 2: AI2 3: AI3 4: PULSE setting 5: Communication reference 6: MIN (AI1,AI2) 7: MAX (AI1,AI2) The full range of 1 ~ 7 correspond to C1-48	0	☆
C1-48	Torque's upper limit digit setting in speed control mode	0% ~ 200.0%	150%	☆
C1-49	Reserved			
C1-50	Reserved			
C1-51	Excitation adjustment proportional gain	0 ~ 60000	2000	☆
C1-52	Excitation adjustment integral gain	0 ~ 60000	1300	☆
C1-53	Torque adjustment proportional gain	0 ~ 60000	2000	☆
C1-54	Torque adjustment integral gain	0 ~ 60000	1300	☆
C1-55	Speed loop integral property	Integral separation 0: InEffective 1: Effective	0	☆
C1-56	Reserved			
C1-57	Reserved			
C1-58	Max weak magnetic current	1% ~ 300%	50%	★
C1-59	Weak magnetic automatic adjustment gain	10% ~ 500%	100%	☆
C1-60	Weak magnetic integral multiple	2 ~ 10	2	☆
C1-61	The first motor's control mode	0: No-speed sensor vector control 1: Speed sensor vector control 2: V/F control	2	★
C1-62	Torque boost	0.0%: (Automatic torque boost) 0.1% ~ 30.0%	Dependent on model	☆
C1-63	VF oscillation suppression gain	0 ~ 100	Dependent on model	☆

6. Functional parameter list

Function code	Item	Setting range	Factory default	Change
<b>C2: The 2nd motor's parameters</b>				
C2-00	Selection of motor type	0: Ordinary asynch. motor 1: Freq.-conversion asynch. motor	0	★
C2-01	Motor's rated power	0.1kW ~ 1000.0kW	Dependent on model	★
C2-02	Motor's rated voltage	1V ~ 2000V	Dependent on model	★
C2-03	Motor's rated current	0.01A ~ 655.35A (power of frequency converter≤55kW) 0.1A ~ 6553.5A (power of frequency converter>55kW)	Dependent on model	★
C2-04	Motor's rated frequency	0.01Hz ~ max frequency	Dependent on model	★
C2-05	Motor's rated speed	1rpm ~ 65535rpm	Dependent on model	★
C2-06	Asynch motor's stator resistance	0.001Ω ~ 65.535Ω (power of frequency converter≤55kW) 0.0001Ω ~ 6.5535Ω (power of frequency converter>55kW)	Dependent on model	★
C2-07	Asynch motor's rotor resistance	0.001Ω ~ 65.535Ω (power of frequency converter≤55kW) 0.0001Ω ~ 6.5535Ω (power of frequency converter>55kW)	Dependent on model	★
C2-08	Leakage reactance of asynch motor	0.01mH ~ 655.35mH (power of frequency converter≤55kW) 0.001mH ~ 65.535mH (power of frequency converter>55kW)	Dependent on model	★
C2-09	Mutual inductive reactance of asynch motor	0.1mH ~ 6553.5mH (power of frequency converter≤55kW) 0.01mH ~ 655.35mH (power of frequency converter>55kW)	Dependent on model	★
C2-10	No-load current of asynch motor	0.01A ~ C2-03 (power of frequency converter≤55kW) 0.1A ~ C2-03 (power of frequency converter>55kW)	Dependent on model	★
C2-16	Reserved			
C2-17	Reserved			
C2-18	Reserved			
C2-19	Reserved			
C2-20	Reserved			
C2-21	Reserved			
C2-27	Encoder lines	1 ~ 65535	1024	★

Function code	Item	Setting range	Factory default	Change
C2-28	Encoder type	0:ABZ incremental encoder 1: UVW incremental encoder 2: Rotary transformer 3: Sine and cosine encoder 4: Line-saving UVW encoder	0	★
C2-29	Reserved			
C2-30	ABZ phase sequence of ABZ encoder	0: Forward 1: Reverse	0	★
C2-31	Encoder's mounting angle	0.0 ~ 359.9°	0.0°	★
C2-32	UVW phase sequence of UVW encoder	0: Forward 1: Reverse	0	★
C2-33	UVW encoder's offset angle	0.0 ~ 359.9°	0.0°	★
C2-34	Number of pole pairs of resolver	1 ~ 65535	1	★
C2-35	Reserved			
C2-36	Speed feedback PG broken line detecting time	0.0: No action 0.1s ~ 10.0s	0.0	★
C2-37	Tuning selection	0: No operation 1: Static tuning of asynch motor 2: Complete tuning of asynch motor	0	★
C2-38	Speed loop proportional gain 1	1 ~ 100	30	☆
C2-39	Speed loop integral time 1	0.01s ~ 10.00s	0.50s	☆
C2-40	Switchover frequency 1	0.00 ~ C2-43	5.00Hz	☆
C2-41	Speed loop proportional gain 1	1 ~ 100	20	☆
C2-42	Speed loop integral time 2	0.01s ~ 10.00s	1.00s	☆
C2-43	Switchover frequency 2	C2-40 ~ max frequency	10.00Hz	☆
C2-44	Vector control slip gain	50% ~ 200%	100%	☆
C2-45	Speed loop filter time constant	0.000s ~ 0.100s	0.000s	☆
C2-46	Vector control overexcitation gain	0 ~ 200	64	☆
C2-47	Torque's upper limit source in speed control mode	0: Function code C2-48 setting 1: A11 2: A12 3: A13 4: PULSE setting 5: Communication reference 6: MIN (A11,A12) 7: MAX (A11,A12) The full range of 1 ~ 7 correspond to C2-48	0	☆

6. Functional parameter list

Function code	Item	Setting range	Factory default	Change
C2-48	Torque's upper limit digit setting in speed control mode	0.0% ~ 200.0%	150%	☆
C2-49	Reserved			
C2-50	Reserved			
C2-51	Excitation adjustment proportional gain	0 ~ 60000	2000	☆
C2-52	Excitation adjustment integral gain	0 ~ 60000	1300	☆
C2-53	Torque adjustment proportional gain	0 ~ 60000	2000	☆
C2-54	Torque adjustment integral gain	0 ~ 60000	1300	☆
C2-55	Speed loop integral property	Integral separation 0: InEffective 1: Effective	0	☆
C2-56	Reserved			
C2-57	Reserved			
C2-58	Max weak magnetic current	1% ~ 300%	50%	★
C2-59	Weak magnetic automatic adjustment gain	10% ~ 500%	100%	☆
C2-60	Weak magnetic integral multiple	2 ~ 10	2	☆
C2-61	The 2nd motor's control mode	0: No-speed sensor vector control 1: Speed sensor vector control 2: V/F control	2	★
C2-62	Selection of the 2nd motor's accel-decel time	0: The same as the 1st motor 1: Accel-decel time 1 2: Accel-decel time 2 3: Accel-decel time 3 4: Accel-decel time 4	0	☆
C2-63	The 2nd motor's torque boost	0.0%(Automatic torque boost) 0.1% ~ 30.0%	Dependent on model	☆
C2-65	VF oscillation suppression gain of the 2nd motor	0 ~ 100	Dependent on model	☆



Function code	Item	Setting range	Factory default	Change
<b>C3: The 3rd motor's parameters</b>				
C3-00	Selection of motor type	0: Ordinary asynch. motor 1: Freq.-conversion asynch. motor	0	★
C3-01	Motor's rated power	0.1kW ~ 1000.0kW	Dependent on model	★
C3-02	Motor's rated voltage	1V ~ 2000V	Dependent on model	★
C3-03	Motor's rated current	0.01A ~ 655.35A (power of frequency converter≤55kW) 0.1A ~ 6553.5A (power of frequency converter>55kW)	Dependent on model	★
C3-04	Motor's rated frequency	0.01Hz ~ max frequency	Dependent on model	★
C3-05	Motor's rated speed	1rpm ~ 65535rpm	Dependent on model	★
C3-06	Asynch motor's stator resistance	0.001Ω ~ 65.535Ω (power of frequency converter≤55kW) 0.0001Ω ~ 6.5535Ω (power of frequency converter>55kW)	Dependent on model	★
C3-07	Asynch motor's rotor resistance	0.001Ω ~ 65.535Ω (power of frequency converter≤55kW) 0.0001Ω ~ 6.5535Ω (power of frequency converter>55kW)	Dependent on model	★
C3-08	Leakage reactance of asynch motor	0.01mH ~ 655.35mH (power of frequency converter≤55kW) 0.001mH ~ 65.535mH (power of frequency converter>55kW)	Dependent on model	★
C3-09	Mutual inductive reactance of asynch motor	0.1mH ~ 6553.5mH (power of frequency converter≤55kW) 0.01mH ~ 655.35mH (power of frequency converter>55kW)	Dependent on model	★
C3-10	No-load current of asynchronous motor	0.01A ~ C3-03 (power of frequency converter≤55kW) 0.1A ~ C3-03 (power of frequency converter>55kW)	Dependent on model	★
C3-16	Reserved			
C3-17	Reserved			
C3-18	Reserved			
C3-19	Reserved			
C3-20	Reserved			
C3-21	Reserved			
C3-27	Encoder lines	1 ~ 65535	1024	★

6. Functional parameter list

Function code	Item	Setting range	Factory default	Change
C3-28	Encoder type	0: ABZ incremental encoder 1: UVW incremental encoder 2: Rotary transformer 3: Sine and cosine encoder 4: Line-saving UVW encoder	0	★
C3-29	Reserved			
C3-30	A/B phase sequence of ABZ encoder	0: Forward 1: Reverse	0	★
C3-31	Encoder's mounting angle	0.0 ~ 359.9°	0.0°	★
C3-32	UVW phase sequence of UVW encoder	0: Forward 1: Reverse	0	★
C3-33	UVW encoder's offset angle	0.0 ~ 359.9°	0.0°	★
C3-34	Number of pole pairs of resolver	1 ~ 65535	1	★
C3-35	Reserved			
C3-36	Speed feedback PG broken line detecting time	0.0: No action 0.1s ~ 10.0s	0.0	★
C3-37	Tuning selection	0: No operation 1: Static tuning of asynch motor 2: Complete tuning of asynch motor	0	★
C3-38	Speed loop proportional gain 1	1 ~ 100	30	☆
C3-39	Speed loop integral gain 1	0.01s ~ 10.00s	0.50s	☆
C3-40	Switchover frequency 1	0.00 ~ C3-43	5.00Hz	☆
C3-41	Speed loop proportional gain 2	1 ~ 100	20	☆
C3-42	Speed loop integral time 2	0.01s ~ 10.00s	1.00s	☆
C3-43	Switchover frequency 2	C3-40 ~ max frequency	10.00Hz	☆
C3-44	Vector control slip gain	50% ~ 200%	100%	☆
C3-45	Speed loop filter time constant	0.000s ~ 0.100s	0.000s	☆
C3-46	Vector control overexcitation gain	0 ~ 200	64	☆
C3-47	Torque's upper limit source in speed control mode	0: Function code C3-48 setting 1: AI1 2: AI2 3: AI3 4: PULSE setting 5: Communication reference 6: MIN (AI1,AI2) 7: MAX (AI1,AI2) The full range of 1 ~ 7 correspond to C3-48	0	☆

Function code	Item	Setting range	Factory default	Change
C3-48	Torque's upper limit digit setting in speed control mode	0.0% ~ 200.0%	150%	☆
C3-49	Reserved			
C3-50	Reserved			
C3-51	Excitation adjustment proportional gain	0 ~ 60000	2000	☆
C3-52	Excitation adjustment integral gain	0 ~ 60000	1300	☆
C3-53	Torque adjustment proportional gain	0 ~ 60000	2000	☆
C3-54	Torque adjustment integral gain	0 ~ 60000	1300	☆
C3-55	Speed loop integral property	Integral separation 0: InEffective 1: Effective	0	☆
C3-56	Reserved			
C3-57	Reserved			
C3-58	Max weak magnetic current	1% ~ 300%	50%	★
C3-59	Weak magnetic automatic adjustment gain	10% ~ 500%	100%	☆
C3-60	Weak magnetic integral multiple	2 ~ 10	2	☆
C3-61	The 2nd motor's control mode	0: No-speed sensor vector control 1: Speed sensor vector control 2: V/F control	2	★
C3-62	Selection of the 2nd motor's accel-decel time	0: The same as the 1st motor 1: Accel-decel time 1 2: Accel-decel time 2 3: Accel-decel time 3 4: Accel-decel time 4	0	☆
C3-63	The 2nd motor's torque boost	0.0%(Automatic torque boost) 0.1% ~ 30.0%	Dependent on model	☆
C3-65	VF oscillation suppression gain of the 2nd motor	0 ~ 100	Dependent on model	☆

6. Functional parameter list

Function code	Item	Setting range	Factory default	Change
<b>C4: The 4th motor's parameters</b>				
C4-00	Selection of motor type	0: Ordinary asynch. motor 1: Freq.-conversion asynch. motor	0	★
C4-01	Motor's rated power	0.1kW ~ 1000.0kW	Dependent on model	★
C4-02	Motor's rated voltage	1V ~ 2000V	Dependent on model	★
C4-03	Motor's rated current	0.01A ~ 655.35A (power of frequency converter≤55kW) 0.1A ~ 6553.5A (power of frequency converter>55kW)	Dependent on model	★
C4-04	Motor's rated frequency	0.01Hz ~ max frequency	Dependent on model	★
C4-05	Motor's rated speed	1rpm ~ 65535rpm	Dependent on model	★
C4-06	Asynch motor's stator resistance	0.001Ω ~ 65.535Ω (power of frequency converter≤55kW) 0.0001Ω ~ 6.5535Ω (power of frequency converter>55kW)	Dependent on model	★
C4-07	Asynch motor's rotor resistance	0.001Ω ~ 65.535Ω (power of frequency converter≤55kW) 0.0001Ω ~ 6.5535Ω (power of frequency converter>55kW)	Dependent on model	★
C4-08	Leakage reactance of asynch motor	0.01mH ~ 655.35mH (power of frequency converter≤55kW) 0.001mH ~ 65.535mH (power of frequency converter>55kW)	Dependent on model	★
C4-09	Mutual inductive reactance of asynch motor	0.1mH ~ 6553.5mH (power of frequency converter≤55kW) 0.01mH ~ 655.35mH (power of frequency converter>55kW)	Dependent on model	★
C4-10	No-load current of asynchronous motor	0.01A ~ C4-03 (power of frequency converter≤55kW) 0.1A ~ C4-03 (power of frequency converter>55kW)	Dependent on model	★
C4-16	Reserved			
C4-17	Reserved			
C4-18	Reserved			
C4-19	Reserved			
C4-20	Reserved			
C4-21	Reserved			
C4-27	Encoder lines	1 ~ 65535	1024	★

Function code	Item	Setting range	Factory default	Change
C4-28	Encoder type	0: ABZ incremental encoder 1: UVW incremental encoder 2: Rotary transformer 3: Sine and cosine encoder 4: Line-saving UVW encoder	0	★
C4-29	Reserved			
C4-30	A/B phase sequence of ABZ encoder	0: Forward 1: Reverse	0	★
C4-31	Encoder's mounting angle	0.0 ~ 359.9°	0.0°	★
C4-32	UVW phase sequence of UVW encoder	0: Forward 1: Reverse	0	★
C4-33	UVW encoder's offset angle	0.0 ~ 359.9°	0.0°	★
C4-34	Number of pole pairs of resolver	1 ~ 65535	1	★
C4-35	Reserved			
C4-36	Speed feedback PG broken line detecting time	0.0: No action 0.1s ~ 10.0s	0.0	★
C4-37	Tuning selection	0: No operation 1: Static tuning of asynch motor 2: Complete tuning of asynch motor	0	★
C4-38	Speed loop proportional gain 1	1 ~ 100	30	☆
C4-39	Speed loop integral gain 1	0.01s ~ 10.00s	0.50s	☆
C4-40	Switchover frequency 1	0.00 ~ C4-43	5.00Hz	☆
C4-41	Speed loop proportional gain 2	1 ~ 100	20	☆
C4-42	Speed loop integral time 2	0.01s ~ 10.00s	1.00s	☆
C4-43	Switchover frequency 2	C4-40 ~ max frequency	10.00Hz	☆
C4-44	Vector control slip gain	50% ~ 200%	100%	☆
C4-45	Speed loop filter time constant	0.000s ~ 0.100s	0.000s	☆
C4-46	Vector control overexcitation gain	0 ~ 200	64	☆
C4-47	Torque's upper limit source in speed control mode	0: Function code C4-48 setting 1: AI1 2: AI2 3: AI3 4: PULSE setting 5: Communication reference 6: MIN (AI1,AI2) 7: MAX (AI1,AI2) The full range of 1 ~ 7 correspond to C4-48	0	☆

6. Functional parameter list

Function code	Item	Setting range	Factory default	Change
C4-48	Torque's upper limit digit setting in speed control mode	0.0% ~ 200.0%	150%	☆
C4-49	Reserved			
C4-50	Reserved			
C4-51	Excitation adjustment proportional gain	0 ~ 60000	2000	☆
C4-52	Excitation adjustment integral gain	0 ~ 60000	1300	☆
C4-53	Torque adjustment proportional gain	0 ~ 60000	2000	☆
C4-54	Torque adjustment integral gain	0 ~ 60000	1300	☆
C4-55	Speed loop integral property	Integral separation 0: InEffective 1: Effective	0	☆
C4-56	Reserved			
C4-57	Reserved			
C4-58	Max weak magnetic current	1% ~ 300%	50%	★
C4-59	Weak magnetic automatic adjustment gain	10% ~ 500%	100%	☆
C4-60	Weak magnetic integral multiple	2 ~ 10	2	☆
C4-61	The 2nd motor's control mode	0: No-speed sensor vector control 1: Speed sensor vector control 2: V/F control	2	★
C4-62	Selection of the 2nd motor's accel-decel time	0: The same as the 1st motor 1: Accel-decel time 1 2: Accel-decel time 2 3: Accel-decel time 3 4: Accel-decel time 4	0	☆
C4-63	The 2nd motor's torque boost	0.0%(Automatic torque boost) 0.1% ~ 30.0%	Dependent on model	☆
C4-65	VF oscillation suppression gain of the 2nd motor	0 ~ 100	Dependent on model	☆

Function code	Item	Setting range	Factory default	Change
<b>C5: V/F control parameters</b>				
C5-00	V/F curve setting	0: Linear V/F 1: Multipoint V/F 2: Square V/F 3: 1.2nd power V/F 4: 1.4th power V/F 6: 1.6th power V/F 8: 1.8th power V/F 10: VF complete separation mode 11: VF semi-separation mode	0	★
C5-01	Cutoff freq. of torque boost	0.00Hz ~ max frequency	50.00Hz	★
C5-02	Multipoint VF freq. point 1	0.00Hz ~ C5-04	0.00Hz	★
C5-03	Multipoint VF voltage point 1	0.0% ~ 100.0%	0.0%	★
C5-04	Multipoint VF freq. point 2	C5-02 ~ C5-06	0.00Hz	★
C5-05	Multipoint VF voltage point 2	0.0% ~ 100.0%	0.0%	★
C5-06	Multipoint VF freq. point 3	C5-04 ~ C1-04	0.00Hz	★
C5-07	Multipoint VF voltage point 3	0.0% ~ 100.0%	0.0%	★
C5-08	VF slip freq. comp. gain	0.0% ~ 200.0%	0.0%	☆
C5-09	VF overexcitation gain	0 ~ 200	64	☆
C5-10	Voltage source of VF separation	0: digit setting (C5-11) 1: AI1 2: AI2 3: AI3 4: PULSE setting (D15) 5: multistage command 6: simple PLC 7: PID 8: Communication setting Note: 100.0% corresponds to motor's rated voltage	0	☆
C5-11	Voltage digital setting of VF separation	0V ~ motor's rated voltage	0V	☆
C5-12	Voltage rising time of VF separation	0.0s ~ 1000.0s Note: It means the time that 0V rises to the motor's rated voltage	0.0s	☆
<b>C6: Vector control parameters</b>				
C6-00	Speed/torque control mode selection	0: Speed control 1: Torque control	0	★

6. Functional parameter list

Function code	Item	Setting range	Factory default	Change
C6-01	Selection of torque setting source in torque control mode	0: digit setting 1 (C6-03) 1: AI1 2: AI2 3: AI3 4: PULSE 5: Communication reference 6: MIN (AI1,AI2) 7: MAX (AI1,AI2) (The full range of 1 ~ 7 corresponds to digit setting of C6-03)	0	★
C6-02	Reserved			
C6-03	Torque digit setting in torque control mode	-200.0% ~ 200.0%	150.0%	☆
C6-04	Reserved			
C6-05	Forward max freq. of torque control	0.00Hz ~ max frequency	50.00Hz	☆
C6-06	Reverse max freq. of torque control	0.00Hz ~ max frequency	50.00Hz	☆
C6-07	Torque control accel time	0.00s ~ 650.00s	0.00s	☆
C6-08	Torque control decel time	0.00s ~ 650.00s	0.00s	☆

**Group F: Functional control parameters**

Function code	Item	Setting range	Factory default	Change
<b>F0: Control and set parameters</b>				
F0-00	Selection of command source	0: Operating panel's command channel (REMOTE OFF) 1: Terminal command channel (REMOTE ON) 2: Communication command channel (REMOTE FLASHING)	0	☆
F0-01	Main frequency source X selection	0: Digit setting (preset frequency F0-06, UP/DOWN modifiable, no memory when power off) 1: Digit setting (preset frequency F0-06, UP/DOWN modifiable, memory when power off) 2: AI1 3: AI2 4: AI3 5: PULSE setting (DI5) 6: Multistage command 7: Simple PLC 8: PID 9: Communication setting	1	★

6



Function code	Item	Setting range	Factory default	Change
F0-02	Auxiliary frequency source Y selection	Same as F0-01 (main frequency source X selection)	0	★
F0-03	Range selection of auxiliary frequency source Y when superposing	0: Relative to max frequency 1: Relative to frequency source X	0	☆
F0-04	Range of auxiliary frequency source Y when superposing	0% ~ 150%	100%	☆
F0-05	Frequency source selection	Ones place: Frequency source selection 0: Main frequency source X 1: Main and auxiliary operation result (operation relation is determined by tens place) 2: Switch between main frequency source X and auxiliary freq. source Y 3: Switch between main frequency source X and main & auxiliary operation results 4: Switch between auxiliary frequency Source Y and main & auxiliary operation results Tens place: Main & auxiliary operation relation of frequency source 0: Main + Auxiliary 1: Main – Auxiliary 2: Max value of the two 3: Min value of the two	00	☆
F0-06	Preset frequency	0.00Hz ~ max frequency (F0-07)	50.00Hz	☆
F0-07	Max frequency	50.00Hz ~ 500.00Hz	50.00Hz	★
F0-08	Upper limit frequency source	0: F0-09 setting 1: AI1 2: AI2 3: AI3 4: PULSE setting 5: Communication reference	0	★
F0-09	Upper limit frequency	Lower limit frequency F0-11 ~ max frequency F0-07	50.00Hz	☆
F0-10	Upper limit frequency offset	0.00Hz ~ max frequency F0-07	0.00Hz	☆
F0-11	Lower limit frequency	0.00Hz ~ upper limit frequency F0-09	0.00Hz	☆
F0-12	Reserved			
F0-13	Auxiliary frequency source's offset frequency in superimposing	0.00Hz ~ max frequency F0-07	0.00Hz	☆
F0-14	Reserved			

6. Functional parameter list

Function code	Item	Setting range	Factory default	Change
F0-15	Digital setting frequency shutdown memory selection	0: No memory 1: Memory	1	☆
F0-16	Frequency command UP/DOWN reference when running	0: Running frequency 1: Set frequency	0	★
F0-17	Command source's bound frequency source	Ones place: Operating panel command binds frequency source selection 0: No binding 1: Digital set frequency 2: AI1 3: AI2 4: AI3 5: PULSE setting (DI5) 6: Multistage speed 7: Simple PLC 8: PID 9: Communication setting Tens place: Terminal command binds frequency source selection Hundreds place: Communication Command binds frequency source selection Thousands place: Auto run binds frequency source selection	0000	☆
F0-18	Skip frequency 1	0.00Hz ~ max frequency	0.00Hz	☆
F0-19	Skip frequency 2	0.00Hz ~ max frequency	0.00Hz	☆
F0-20	Amplitude of skip frequency	0.00Hz ~ max frequency	0.01Hz	☆
F0-21	Running direction	0: Same direction 1: Opposite direction	0	☆
F0-22	FWD/REV dead zone time	0.0s ~ 3000.0s	0.0s	☆
F0-23	REV control enable	0: Enable 1: Disenable	0	☆
F0-24	Operation mode that set frequency lower than the lower limit frequency	0: Run with lower limit frequency. 1: Shutdown 2: Run at zero speed	0	☆
F0-25	Drop control	0.00Hz ~ 10.00Hz	0.00Hz	☆
F0-26	Start mode	0: Direct start 1: Speed tracking restart 2: Pre-excitation start (AC asynch motor)	0	☆
F0-27	Start protection selection	0: No protection 1: Protection	0	☆

Function code	Item	Setting range	Factory default	Change
F0-28	Start frequency	0.00Hz ~ 10.00Hz	0.00Hz	☆
F0-29	Start frequency holding time	0.0s ~ 100.0s	0.0s	★
F0-30	Start DC braking time/pre-excitation time	0.0s ~ 100.0s	0.0s	★
F0-31	Start DC braking current/pre-excitation current	0% ~ 100%	0%	★
F0-32	Stop mode	0: Decel stop 1: Free stop 2: Positioning stop	0	☆
F0-33	Initial frequency of stop DC braking	0.00Hz ~ max frequency	0.00Hz	☆
F0-34	Stop DC braking waiting time	0.0s ~ 100.0s	0.0s	☆
F0-35	Stop DC braking time	0.0s ~ 100.0s	0.0s	☆
F0-36	Stop DC braking current	0% ~ 100%	0%	☆
F0-37	Acceleration/Deceleration time unit	0: 1s 1: 0.1s 2: 0.01s	1	★
F0-38	Acceleration/Deceleration time base frequency	0: Max frequency (F0-07) 1: Set frequency 2: 100.00Hz	0	★
F0-39	Acceleration time 1	0.00s ~ 650.00s (F0-37=2) 0.0s ~ 6500.0s (F0-37=1) 0s ~ 65000s (F0-37=0)	Dependent on model	☆
F0-40	Deceleration time 1	Same as F0-39	Dependent on model	☆
F0-41	Acceleration time 2	0.0s ~ 6500.0s	Dependent on model	☆
F0-42	Deceleration time 2	0.0s ~ 6500.0s	Dependent on model	☆
F0-43	Acceleration time 3	0.0s ~ 6500.0s	Dependent on model	☆
F0-44	Deceleration time 3	0.0s ~ 6500.0s	Dependent on model	☆
F0-45	Acceleration time 4	0.0s ~ 6500.0s	Dependent on model	☆
F0-46	Deceleration time 4	0.0s ~ 6500.0s	Dependent on model	☆
F0-47	Acceleration/Deceleration mode	0: Linear acceleration/deceleration 1: S-curve acceleration/deceleration A 2: S-curve acceleration/deceleration B	0	★

6. Functional parameter list

Function code	Item	Setting range	Factory default	Change
F0-48	S curve beginning-segment time proportion	0.0% ~ (100.0%-F0-49)	30.00%	★
F0-49	S curve ending-segment time proportion	0.0% ~ (100.0%-F0-48)	30.00%	★
F0-50	Jump frequency during acceleration/deceleration	0: Ineffective 1: Effective	0	☆
F0-51	Reserved			
F0-52	Reserved			
F0-53	Frequency switchover point between acceleration time 1 and acceleration time 2	0.00Hz ~ max frequency	0.00Hz	☆
F0-54	Frequency switchover point between deceleration time 1 and deceleration time 2	0.00Hz ~ max frequency	0.00Hz	☆
F0-55	Terminal jogging priority	0: InEffective 1: Effective	0	☆
F0-56	JOG running frequency	0.00Hz ~ max frequency	2.00Hz	☆
F0-57	JOG acceleration time	0.0s ~ 6500.0s	20.0s	☆
F0-58	JOG deceleration time	0.0s ~ 6500.0s	20.0s	☆
F0-59	Speed tracking mode	0: Start from stop frequency 1: Start from zero 2: Start from max frequency	0	★
F0-60	Speed tracking	1 ~ 100	20	☆
F0-61	Brake rate	0% ~ 100%	100%	☆
<b>F1: Input terminal's parameters</b>				
F1-00	DI1 terminal's function selection	0: No function 1: FWD running 2: REV running 3: Three-line running control 4: FJOG 5: RJOG 6: Terminal UP 7: Terminal DOWN 8: Free stop 9: Fault RESET 10: PAUSE 11: External fault's normally-open input 12: Multistage command terminal 1 13: Multistage command terminal 2 14: Multistage command terminal 3 15: Multistage command terminal 4	1	★

Function code	Item	Setting range	Factory default	Change
F1-01	DI2 terminal's function selection	16: Acceleration and deceleration time selection terminal 1	4	★
F1-02	DI3 terminal's function selection	17: Acceleration and deceleration time selection terminal 2	9	★
F1-03	DI4 terminal's function selection	18: Switchover of frequency source 19: UP/DOWN setting clear (terminal and keyboard)	12	★
F1-04	DI5 terminal's function selection	20: Running command switching terminal	13	★
F1-05	DI6 terminal's function selection	21: Acceleration and deceleration forbidden	0	★
F1-06	DI7 terminal's function selection	22: PID Pause	0	★
F1-07	DI8 terminal's function selection	23: PLC Reset	0	★
F1-08	DI9 terminal's function selection	24: Swing frequency pause 25: Counter input 26: Counter reset	0	★
F1-09	DI10 terminal's function selection	27: Length count input 28: Length reset 29: Torque control forbidden 30: PULSE frequency input (Effective for DI5 only) 32: Immediate DC brake 33: External fault's normally-close input 34: Frequency modification enable 35: PID acting direction reverse 36: External stop terminal 1 37: Control command switching terminal 2 38: PID integration pause 39: Switch between frequency source X and preset frequency 40: Switch between frequency source Y and preset frequency 41: Motor's selection terminal 1 42: Motor's selection terminal 2 43: PID parameters' switching 44: User's defined fault 1 45: User's defined fault 2 46: Switching between speed control and torque control 47: Emergency stop 48: External stop terminal 2 49: Deceleration DC braking 50: Current running hour clear 51: Location arrive input signal 52 ~ 59: Reserved	0	★

6. Functional parameter list

Function code	Item	Setting range	Factory default	Change
F1-10	DI filter time	0.000s ~ 1.000s	0.010s	☆
F1-11	DI1 delay time	0.0s ~ 3600.0s	0.0s	★
F1-12	DI2 delay time	0.0s ~ 3600.0s	0.0s	★
F1-13	DI3 delay time	0.0s ~ 3600.0s	0.0s	★
F1-14	DI terminal's effective mode selection 1	0: High level effective 1: Low level effective Ones place: DI1 Tens place: DI2 Hundreds place: DI3 Thousands place: DI4 Ten thousands place: DI5	00000	★
F1-15	DI terminal's effective mode selection 2	0: High level effective 1: Low level effective Ones place: DI6 Tens place: DI7 Hundreds place: DI8 Thousands place: DI9 Ten thousands place: DI10	00000	★
F1-16	Terminal command mode	0: Two-line type 1 1: Two-line type 2 2: Three-line type 1 3: Three-line type 2	0	★
F1-17	Terminal UP/DOWN change rate	0.001Hz/s ~ 65.535Hz/s	1.000Hz/s	☆
F1-18	PULSE min input	0.00kHz ~ F1-20	0.00kHz	☆
F1-19	Setting corresponding to PULSE min input	-100.0% ~ 100.0%	0.00%	☆
F1-20	PULSE max input	F1-18 ~ 100.00kHz	50.00kHz	☆
F1-21	Setting corresponding to PULSE max input	-100.0% ~ 100.0%	100.00%	☆
F1-22	PULSE filter time	0.00s ~ 10.00s	0.10s	☆
F1-23	AI curve selection	Ones place: AI1 curve selection 1: Curve 1 (2 points, see F1-25 ~ F1-28) 2: Curve 2(2 points, see F1-32 ~ F1-35) 3: Curve 3(2 points, see F1-37 ~ F1-40) 4: Curve 4(2 points, see F1-42 ~ F1-49) 5: Curve 5(2 points, see F1-50 ~ F1-57) Tens place: AI2 curve selection, Same as above Hundreds place: AI3 curve selection, Same as above	321	☆

Function code	Item	Setting range	Factory default	Change
F1-24	Setting selection of AI lower than min input	Ones place: setting selection of AI1 lower than min input 0: Corresponding to min input setting 1: 0.0% Tens place: setting selection of AI2 lower than min input, Same as above Hundreds place: setting selection of AI3 lower than min input, Same as above	000	☆
F1-25	Min input of AI curve 1	0.00V ~ F1-27	0.00V	☆
F1-26	Setting corresponding to min input of AI curve 1	-100.0% ~ +100.0%	0.0%	☆
F1-27	Max input of AI curve 1	F1-25 ~ +10.00V	10.00V	☆
F1-28	Setting corresponding to max input of AI curve 1	-100.0% ~ +100.0%	100.0%	☆
F1-29	AI1 filter time	0.00s ~ 10.00s	0.10s	☆
F1-30	Lower limit of AI1 input voltage protection value	0.00V ~ F1-31	3.10V	☆
F1-31	Upper limit of AI1 input voltage protection value	F1-30 ~ 10.00V	6.80V	☆
F1-32	Min input of AI curve 2	0.00V ~ F1-34	0.00V	☆
F1-33	Setting corresponding to min input of AI curve 2	-100.0% ~ +100.0%	0.0%	☆
F1-34	Max input of AI curve 2	F1-32 ~ +10.00V	10.00V	☆
F1-35	Setting corresponding to max input of AI curve 2	-100.0% ~ +100.0%	100.0%	☆
F1-36	AI 2 filter time	0.00s ~ 10.00s	0.10s	☆
F1-37	Min input of AI curve 3	-10.00V ~ F1-39	-10.00V	☆
F1-38	Setting corresponding to min input of AI curve 3	-100.0% ~ +100.0%	-100.0%	☆
F1-39	Max input of AI curve 3	F1-37 ~ +10.00V	10.00V	☆
F1-40	Setting corresponding to max input of AI curve 3	-100.0% ~ +100.0%	100.0%	☆
F1-41	AI 3 filter time	0.00s ~ 10.00s	0.10s	☆
F1-42	Min input of AI curve 4	-10.00V ~ F1-44	0.00V	☆
F1-43	Setting corresponding to min input of AI curve 4	-100.0% ~ +100.0%	0.0%	☆
F1-44	Inflection point 1 input of AI curve 4	F1-42 ~ F1-46	3.00V	☆
F1-45	Setting corresponding to inflection point 1 input of AI curve 4	-100.0% ~ +100.0%	30.0%	☆
F1-46	Inflection point 2 input of AI curve 4	F1-44 ~ F1-48	6.00V	☆

6. Functional parameter list

Function code	Item	Setting range	Factory default	Change
F1-47	Setting corresponding to inflection point 2 input of AI curve 4	-100.0% ~ +100.0%	60.0%	☆
F1-48	Max input of AI curve 4	F1-46 ~ +10.00V	10.00V	☆
F1-49	Setting corresponding to max input of AI curve 4	-100.0% ~ +100.0%	100.0%	☆
F1-50	Min input of AI curve 5	-10.00V ~ F1-52	-10.00V	☆
F1-51	Setting corresponding to min input of AI curve 5	-100.0% ~ +100.0%	-100.0%	☆
F1-52	Inflection point 1 input of AI curve 5	F1-50 ~ F1-54	-3.00V	☆
F1-53	Setting corresponding to inflection point 1 input of AI curve 5	-100.0% ~ +100.0%	-30.0%	☆
F1-54	Inflection point 2 input of AI curve 5	F1-52 ~ F1-56	3.00V	☆
F1-55	Setting corresponding to inflection point 2 input of AI curve 5	-100.0% ~ +100.0%	30.0%	☆
F1-56	Max input of AI curve 5	F1-54 ~ +10.00V	10.00V	☆
F1-57	Setting corresponding to max input of AI curve 5	-100.0% ~ +100.0%	100.0%	☆
F1-66	AI1 set skip point	-100.0% ~ +100.0%	0.0%	☆
F1-67	AI1 set skip amplitude	0.0% ~ +100.0%	0.5%	☆
F1-68	AI2 set skip point	-100.0% ~ +100.0%	0.0%	☆
F1-69	AI2 set skip amplitude	0.0% ~ +100.0%	0.5%	☆
F1-70	AI3 set skip point	-100.0% ~ +100.0%	0.0%	☆
F1-71	AI3 set skip amplitude	0.0% ~ +100.0%	0.5%	☆
<b>F2: Output terminal parameters</b>				
F2-00	DO2 terminal output mode selection	0: Pulse output (FMP) 1: On-off output (FMR)	0	☆
F2-01	On-off output function selection	0: No output 1: Frequency converter in operation 2: Fault output (fault stop)	0	☆



Function code	Item	Setting range	Factory default	Change
F2-02	Control board's relay function selection (TA-TB-TC)	3: Frequency level detection FDT1 output 4: Frequency reach	2	☆
F2-03	Expansion card's relay output function selection (EA-EB-EC)	5: Running at zero speed (no output at stop) 6: Motor overload alarm	0	☆
F2-04	DO1 output function selection	7: frequency converter overload alarm	1	☆
F2-05	Expansion card DO3 output selection	8: Set count value reach 9: Designated count value reach 10: Length reach 11: PLC circulation complete 12: Total runtime reach 13: Frequency in limitation 14: Torque in limitation 15: Ready for run 16: AI1>AI2 17: Upper limit frequency reach 18: Lower limit frequency reach 19: Undervoltage state output 20: Communication Setting 23: Running 2 at zero speed (output at stop) 24: Total power-on time reach 25: Frequency level detection FDT2 output alarm 26: Frequency 1 reach output 27: Frequency 2 reach output 28: Current 1 reach output 29: Current 2 reach output 30: Timing reach output 31: AI1 input overrun 32: Load dropping 33: REV running 34: Zero current state 35: Module temperature reach 36: Output current overrun 37: Lower limit frequency reach (Continue output after stopping) 38: Alarm output (Continue running) 39: Motor over temp warning 40: Current runtime reach 41: Fault output	4	☆

6. Functional parameter list

Function code	Item	Setting range	Factory default	Change
F2-06	Pulse output function selection	0: Operating frequency	0	☆
F2-07	AO1 output function selection	1: Set frequency	0	☆
F2-08	Expansion card AO2 output function selection	2: Output current 3: Output torque 4: Output power 5: Output voltage 6: Pulse input (100% corresponds to 100kHz) 7: AI1 8: AI2 9: AI3(expansion card) 10: Length 11: Count value 12: Communication setting 13: Motor speed 14: Output current (100% corresponds to 100A) 15: Bus voltage (100% corresponds to 100V) 16: Motor output torque (actual value, Percent relative to the motor)	1	☆
F2-09	Pulse output max freq.	0.01kHz ~ 100.00kHz	50.00kHz	☆
F2-10	AO1 bias coefficient	-100.0% ~ +100.0%	0.0%	☆
F2-11	AO1 gain	-10.00 ~ +10.00	1.00	☆
F2-12	Expansion card AO2 bias coefficient	-100.0% ~ +100.0%	0.0%	☆
F2-13	Expansion card AO2 gain	-10.00 ~ +10.00	1.00	☆
F2-14	Reserved			
F2-15	Reserved			
F2-16	Reserved			

Function code	Item	Setting range	Factory default	Change
F2-17	On-off output delay time	0.0s ~ 3600.0s	0.0s	☆
F2-18	RELAY1 output delay time	0.0s ~ 3600.0s	0.0s	☆
F2-19	RELAY 2 output delay time	0.0s ~ 3600.0s	0.0s	☆
F2-20	DO1 output delay time	0.0s ~ 3600.0s	0.0s	☆
F2-21	DO3 output delay time	0.0s ~ 3600.0s	0.0s	☆
F2-22	DO output terminal's effective state selection	0: Positive logic 1: Negative logic Ones place: on-off Tens place: RELAY 1 Hundreds place: RELAY 2 Thousands place: DO1 Ten thousands place: DO3	00000	☆
F2-23	Freq. detection value (FDT1)	0.00Hz ~ max frequency	50.00Hz	☆
F2-24	Freq. detection value (FDT2)	0.00Hz ~ max frequency	50.00Hz	☆
F2-25	Freq. detection width	0.0% ~ 100.0%(max frequency)	0.0%	☆
F2-26	Freq. detection lagged value(FDT1)	0.0% ~ 100.0% (FDT1 level)	5.0%	☆
F2-27	Freq. detection lagged value (FDT2)	0.0% ~ 100.0% (FDT2 level)	5.0%	☆
F2-28	Random reach freq. detection value 1	0.00Hz ~ max frequency	50.00Hz	☆
F2-29	Random reach freq. detection width 1	0.00Hz ~ 100% (max frequency)	0.0%	☆
F2-30	Random reach freq. detection value 2	0.00Hz ~ max frequency	50.00Hz	☆
F2-31	Random reach freq. detection width 2	0.00Hz ~ 100% (max frequency)	0.0%	☆
F2-32	Zero current detection level	0.0% ~ 300.0% 100% corresponding to motor's rated current	5.0%	☆
F2-33	Zero current detection delay time	0.01s ~ 600.00s	0.10s	☆
F2-34	Output current overrun	0(No detection) 0.1%~300.0% (motor's rated current)	200.0%	☆
F2-35	Output current overrun detection delay time	0.00s ~ 600.00s	0.00s	☆
F2-36	Random reach current 1	0.0% ~ 300.0% (motor's rated current)	100.0%	☆
F2-37	Width of random reach current 1	0.0% ~ 300.0% (motor's rated current)	0.0%	☆
F2-38	Random reach current 2	0.0% ~ 300.0% (motor's rated current)	100.0%	☆

6. Functional parameter list

Function code	Item	Setting range	Factory default	Change
F2-39	Width of random reach current 2	0.0% ~ 300.0%(motor's rated current)	0.0%	☆
F2-40	Module temp reach	0℃ ~ 100℃	75℃	☆
F2-41	Set total power-on reach time	0h ~ 65000h	0h	☆
F2-42	Set total run reach time	0h ~ 65000h	0h	☆
F2-43	Timing function selection	0: Effective 1: Ineffective	0	★
F2-44	Timing run time selection	0: F2-45 setting 1: AI1 2: AI2 3: AI3 Analog input range corresponds to F2-45	0	★
F2-45	Timing run time	0.0min ~ 6500.0min	0.0min	★
F2-46	Current run reach time setting	0.0min ~ 6500.0min	0.0min	☆
<b>F3: AIAO calibration</b>				
F3-00	AI1 measured voltage 1	0.500V ~ 4.000V	factory calibration	☆
F3-01	AI1 displayed voltage 1	0.500V ~ 4.000V	factory calibration	☆
F3-02	AI1 measured voltage 2	6.000V ~ 9.999V	factory calibration	☆
F3-03	AI1 displayed voltage 2	6.000V ~ 9.999V	factory calibration	☆
F3-04	AI2 measured voltage 1	0.500V ~ 4.000V	factory calibration	☆
F3-05	AI2 displayed voltage 1	0.500V ~ 4.000V	factory calibration	☆
F3-06	AI2 measured voltage 2	6.000V ~ 9.999V	factory calibration	☆
F3-07	AI2 displayed voltage 2	6.000V ~ 9.999V	factory calibration	☆
F3-08	AI3 measured voltage 1	-9.999V ~ 10.000V	factory calibration	☆
F3-09	AI3 displayed voltage 1	-9.999V ~ 10.000V	factory calibration	☆
F3-10	AI3 measured voltage 2	-9.999V ~ 10.000V	factory calibration	☆
F3-11	AI3 displayed voltage 2	-9.999V ~ 10.000V	factory calibration	☆
F3-12	AO1 target voltage 1	0.500V ~ 4.000V	factory calibration	☆

Function code	Item	Setting range	Factory default	Change
F3-13	AO1 measured voltage 1	0.500V ~ 4.000V	factory calibration	☆
F3-14	AO1 target voltage 2	6.000V ~ 9.999V	factory calibration	☆
F3-15	AO1 measured voltage 2	6.000V ~ 9.999V	factory calibration	☆
F3-16	AO2 target voltage 1	0.500V ~ 4.000V	factory calibration	☆
F3-17	AO2 measured voltage 1	0.500V ~ 4.000V	factory calibration	☆
F3-18	AO2 target voltage 2	6.000V ~ 9.999V	factory calibration	☆
F3-19	AO2 measured voltage 2	6.000V ~ 9.999V	factory calibration	☆
<b>F4: Multistage speed and simple PLC parameters</b>				
F4-00	Multistage command 0	-100.0% ~ 100.0%	0.0%	☆
F4-01	Multistage command 1	-100.0% ~ 100.0%	0.0%	☆
F4-02	Multistage command 2	-100.0% ~ 100.0%	0.0%	☆
F4-03	Multistage command 3	-100.0% ~ 100.0%	0.0%	☆
F4-04	Multistage command 4	-100.0% ~ 100.0%	0.0%	☆
F4-05	Multistage command 5	-100.0% ~ 100.0%	0.0%	☆
F4-06	Multistage command 6	-100.0% ~ 100.0%	0.0%	☆
F4-07	Multistage command 7	-100.0% ~ 100.0%	0.0%	☆
F4-08	Multistage command 8	-100.0% ~ 100.0%	0.0%	☆
F4-09	Multistage command 9	-100.0% ~ 100.0%	0.0%	☆
F4-10	Multistage command 10	-100.0% ~ 100.0%	0.0%	☆
F4-11	Multistage command 11	-100.0% ~ 100.0%	0.0%	☆
F4-12	Multistage command 12	-100.0% ~ 100.0%	0.0%	☆
F4-13	Multistage command 13	-100.0% ~ 100.0%	0.0%	☆
F4-14	Multistage command 14	-100.0% ~ 100.0%	0.0%	☆
F4-15	Multistage command 15	-100.0% ~ 100.0%	0.0%	☆
F4-16	Simple PLC running mode	0: Stop after single running 1: Retain final value after single running 2: Continue circulating	0	☆
F4-17	Simple PLC power-off memory selection	Ones place: Power-off memory selection 0: No memory after power-off 1: Memory after power-off Tens place: Stop memory selection 0: No memory after stopping 1: Memory after stopping	00	☆
F4-18	Simple PLC runtime at stage 0	0.0s (h) ~ 6553.5s (h)	0.0s (h)	☆

6. Functional parameter list

Function code	Item	Setting range	Factory default	Change
F4-19	Simple PLC accel/decel time selection at stage 0	0 ~ 3	0	☆
F4-20	Simple PLC runtime at stage 1	0.0s (h) ~ 6553.5s (h)	0.0s (h)	☆
F4-21	Simple PLC accel/decel time selection at stage 1	0 ~ 3	0	☆
F4-22	Simple PLC runtime at stage 2	0.0s (h) ~ 6553.5s (h)	0.0s (h)	☆
F4-23	Simple PLC accel/decel time selection at stage 2	0 ~ 3	0	☆
F4-24	Simple PLC runtime at stage 3	0.0s (h) ~ 6553.5s (h)	0.0s (h)	☆
F4-25	Simple PLC accel/decel time selection at stage 3	0 ~ 3	0	☆
F4-26	Simple PLC runtime at stage 4	0.0s (h) ~ 6553.5s (h)	0.0s (h)	☆
F4-27	Simple PLC accel/decel time selection at stage 4	0 ~ 3	0	☆
F4-28	Simple PLC runtime at stage 5	0.0s (h) ~ 6553.5s (h)	0.0s (h)	☆
F4-29	Simple PLC accel/decel time selection at stage 5	0 ~ 3	0	☆
F4-30	Simple PLC runtime at stage 6	0.0s (h) ~ 6553.5s (h)	0.0s (h)	☆
F4-31	Simple PLC accel/decel time selection at stage 6	0 ~ 3	0	☆
F4-32	Simple PLC runtime at stage 7	0.0s (h) ~ 6553.5s (h)	0.0s (h)	☆
F4-33	Simple PLC accel/decel time selection at stage 7	0 ~ 3	0	☆
F4-34	Simple PLC runtime at stage 8	0.0s (h) ~ 6553.5s (h)	0.0s (h)	☆
F4-35	Simple PLC accel/decel time selection at stage 8	0 ~ 3	0	☆
F4-36	Simple PLC runtime at stage 9	0.0s (h) ~ 6553.5s (h)	0.0s (h)	☆
F4-37	Simple PLC accel/decel time selection at stage 9	0 ~ 3	0	☆
F4-38	Simple PLC runtime at stage 10	0.0s (h) ~ 6553.5s (h)	0.0s (h)	☆
F4-39	Simple PLC accel/decel time selection at stage 10	0 ~ 3	0	☆

Function code	Item	Setting range	Factory default	Change
F4-40	Simple PLC runtime at stage 11	0.0s (h) ~ 6553.5s (h)	0.0s (h)	☆
F4-41	Simple PLC accel/decel time selection at stage 11	0 ~ 3	0	☆
F4-42	Simple PLC runtime at stage 12	0.0s (h) ~ 6553.5s (h)	0.0s (h)	☆
F4-43	Simple PLC accel/decel time selection at stage 12	0 ~ 3	0	☆
F4-44	Simple PLC runtime at stage 13	0.0s (h) ~ 6553.5s (h)	0.0s (h)	☆
F4-45	Simple PLC accel/decel time selection at stage 13	0 ~ 3	0	☆
F4-46	Simple PLC runtime at stage 14	0.0s (h) ~ 6553.5s (h)	0.0s (h)	☆
F4-47	Simple PLC accel/decel time selection at stage 14	0 ~ 3	0	☆
F4-48	Simple PLC runtime at stage 15	0.0s (h) ~ 6553.5s (h)	0.0s (h)	☆
F4-49	Simple PLC accel/decel time selection at stage 15	0 ~ 3	0	☆
F4-50	Simple PLC runtime unit	0: s (s) 1: h (h)	0	☆
F4-51	Multistage command 0 reference	0: Function code F4-00 reference 1: AI1 2: AI2 3: AI3 4: PULSE 5: PID 6: Preset frequency (F0-06) reference UP/DOWN modifiable	0	☆
<b>F5: PID control parameters</b>				
F5-00	PID reference source	0: F5-01 reference 1: AI1 2: AI2 3: AI3 4: Pulse setting (DI5) 5: Communication reference 6: Multistage command reference	0	☆
F5-01	PID value reference	0.0% ~ 100.0%	50.0%	☆

6. Functional parameter list

Function code	Item	Setting range	Factory default	Change
F5-02	PID feedback source	0: AI1 1: AI2 2: AI3 3: AI1-AI2 4: Pulse setting (DI5) 5: Communication give 6: AI1+AI2 7: MAX ( AI1 ,  AI2 ) 8: MIN ( AI1 ,  AI2 )	0	☆
F5-03	PID action direction	0: Positive action 1: Negative action	0	☆
F5-04	PID reference feedback range	0 ~ 65535	1000	☆
F5-05	Proportional gain Kp1	0.0 ~ 100.0	20.0	☆
F5-06	Integral time Ti1	0.01s ~ 10.00s	2.00s	☆
F5-07	Derivative time Td1	0.000s ~ 10.000s	0.000s	☆
F5-08	PID reverse cutoff freq.	0.00 ~ max frequency	2.00Hz	☆
F5-09	PID deviation limit	0.0% ~ 100.0%	0.0%	☆
F5-10	PID derivative amplitude limiting	0.00% ~ 100.00%	0.10%	☆
F5-11	PID reference change time	0.00 ~ 650.00s	0.00s	☆
F5-12	PID feedback filter time	0.00 ~ 60.00s	0.00s	☆
F5-13	PID output filter time	0.00 ~ 60.00s	0.00s	☆
F5-15	Proportional gain kP2	0.0 ~ 100.0	20.0	☆
F5-16	Integral time Ti2	0.01s ~ 10.00s	2.00s	☆
F5-17	Derivative time Td2	0.000s ~ 10.000s	0.000s	☆
F5-18	PID parameter switching conditions	0: No switching 1: Switched via DI terminal 2: Auto switching via deviation	0	☆
F5-19	PID parameter switching deviation 1	0.0% ~ F5-20	20.0%	☆
F5-20	PID parameter switching deviation 2	F5-19 ~ 100.0%	80.0%	☆
F5-21	PID initial value	0.0% ~ 100.0%	0.0%	☆
F5-22	PID initial value holding time	0.00 ~ 650.00s	0.00s	☆
F5-23	Positive max value of two output deviations	0.00% ~ 100.00%	1.00%	☆
F5-24	Negative max value of two output deviations	0.00% ~ 100.00%	1.00%	☆



Function code	Item	Setting range	Factory default	Change
F5-25	PID integral properties	Ones place: integral separation 0: Ineffective 1: Effective Tens place: Does it stop integration after output reaches limit? 0: Continue integrating 1: Stop integrating	00	☆
F5-26	PID feedback loses detection value	0.0%: No judgment of feedback loss 0.1% ~ 100.0%	0.0%	☆
F5-27	PID feedback loses detection time	0.0s ~ 20.0s	0.0s	☆
F5-28	PID stop operation	0: No operating after stopping 1: Operating after stopping	0	☆
<b>F6: Expansion functional parameters</b>				
F6-00	Dormant frequency	0.00Hz ~ wake-up freq.(F6-02)	0.00Hz	☆
F6-01	Dormant delay time	0.0s ~ 6500.0s	0.0s	☆
F6-02	Wake-up frequency	Dormant freq. (F6-00) ~ Max freq. (F0-07)	0.00Hz	☆
F6-03	Wake-up delay time	0.0s ~ 6500.0s	0.0s	☆
<b>F7: Communication parameters</b>				
F7-00	Comm. baud rate	Ones place: MODBUS 0: 300bps 1: 600bps 2: 1200bps 3: 2400bps 4: 4800bps 5: 9600bps 6: 19200bps 7: 38400bps 8: 57600bps 9: 115200bps Tens place: Profibus-DP 0: 9.6 kbps 1: 19.2kbps 2: 45.45kbps 3: 93.75kbps 4: 187.5kbps 5: 500kbps 6: 1.5Mbps 7: 3Mbps 8: 6Mbps 9: 12Mbps Hundreds place: CANopen 0: 125kbps 1: 250kbps 2: 500kbps 3: 1Mbps	005	☆

6. Functional parameter list

Function code	Item	Setting range	Factory default	Change
F7-01	Data format	0: No check (8-N-2) 1: Even parity check (8-E-1) 2: Odd parity check (8-O-1) 3: No check (8-N-1) MODBUS effective	0	☆
F7-02	Machine address	1 ~ 249 0 is broadcast address	1	☆
F7-03	Response delay	0ms ~ 20ms	2ms	☆
F7-04	Comm. timeout	0.0 (Ineffective) 0.1s ~ 60.0s	0.0s	☆
F7-05	Data transmission format selection	Ones place: MODBUS 0: Non-standard MODBUS protocol 1: Standard MODBUS protocol Tens place: Profibus-DP 0: PPO1 format 1: PPO2 format 2: PPO3 format 3: PPO5 format	30	☆
F7-06	Comm. read current resolution	0: 0.01A 1: 0.1A	0	☆
<b>F8: Protection and fault parameters</b>				
F8-00	Auto reset times of fault	0 ~ 20	0	☆
F8-01	Auto reset interval of fault	0.1s ~ 100.0s	1.0s	☆
F8-02	Motor's overload protection selection	0: Disenable 1: Enable	1	☆
F8-03	Motor's overload protection gain	0.20 ~ 10.00	1.00	☆
F8-04	Overvoltage stall gain	0 ~ 100	0	☆
F8-05	Overvoltage stall protection voltage	650.0V ~ 800.0V	770.0V	☆
F8-06	Overcurrent stall gain	0 ~ 100	20	☆
F8-07	Overcurrent stall protection current	100% ~ 200%	150%	☆
F8-08	Power-on ground short circuit protection selection	0: Ineffective 1: Effective	0	☆
F8-09	Braking unit's initial voltage	650V ~ 800V	760V	★
F8-10	Fault DO action selection in auto reset period of fault	0: No action 1: Action	0	☆
F8-11	Input phase loss protection selection	0: Disenable 1: Enable	1	☆
F8-12	Output phase loss protection selection	0: Disenable 1: Enable	1	☆

Function code	Item	Setting range	Factory default	Change
F8-13	The 3rd (latest) fault type	0: No fault	-	●
F8-14	The 2nd fault type	1: Reserved	—	●
F8-15	The 1st fault type	2: Accel overcurrent 3: Decel overcurrent 4: Constant speed overcurrent 5: Accel overvoltage 6: Decel overvoltage 7: Constant speed overvoltage 8: Buffer resistance overload 9: Undervoltage 10: Frequency converter overload 11: Motor overload 12: Input phase loss 13: Output phase loss 14: Module overheat 15: External fault 16: Comm. abnormal 17: Contactor abnormal 18: Current detection abnormal 19: Motor tuning abnormal 20: Function code/PG card abnormal 21: Parameter reading abnormal 22: Freq. converter abnormal 23: Motor grounding short circuit 26: Runtime reach 27: User-defined fault 1 28: User-define fault 2 29: Power-on time reach 30: Load drop 31: PID feedback loses during running 40: Fast current limiting times out 41: Switch motor during running 42: Speed deviation too large 43: Motor overspeed 45: Motor overtemperature 51: Initial position error 55: Load allocation slave fault	—	●
F8-16	Freq. at the 3rd (latest) fault	—	—	●
F8-17	Current at the 3rd (latest) fault	—	—	●
F8-18	Bus voltage at the 3rd (latest) fault	—	—	●
F8-19	Input terminal state at the 3rd (latest) fault	—	—	●

6. Functional parameter list

Function code	Item	Setting range	Factory default	Change
F8-20	Output terminal state at the 3rd (latest) fault	—	—	●
F8-21	Freq. state at the 3rd (latest) fault	—	—	●
F8-22	Power-on time at the 3rd (latest) fault	—	—	●
F8-23	Runtime at the 3rd (latest) fault	—	—	●
F8-26	Freq. at the 2nd fault	—	—	●
F8-27	Current at the 2nd fault	-	-	●
F8-28	Bus voltage at the 2nd fault	-	-	●
F8-29	Input terminal state at the 2nd fault	-	-	●
F8-30	Output terminal state at the 2nd fault	-	-	●
F8-31	Freq. converter's status at the 2nd fault	-	-	●
F8-32	Power-on time at the 2nd fault	-	-	●
F8-33	Runtime at the 2nd fault	-	-	●
F8-36	Freq. at the 1st fault	-	-	●
F8-37	Current at the 1st fault	-	-	●
F8-38	Bus voltage at the 1st fault	-	-	●
F8-39	Input terminal state at the 1st fault	-	-	●
F8-40	Output terminal state at the 1st fault	-	-	●
F8-41	Freq. converter's status at the 1st fault	-	-	●
F8-42	Power-on time at the 1st fault	-	-	●
F8-43	Runtime at the 1st fault	-	-	●
F8-46	Fault protection selection 1	Ones place: motor overload (Err11) 0: Free stop 1: Stop by stop mode 2: Continue running Tens place: Input phase loss (Err12) Hundreds place: Output phase loss (Err13) Thousands place: External fault (Err15) Ten thousands place: Comm. abnormal (Err16)	00000	☆

Function code	Item	Setting range	Factory default	Change
F8-47	Fault protection selection 2	<p>Ones place: Encoder/PG card abnormal (Err20) 0: Free stop</p> <p>Tens place: Function code reading &amp; writing abnormal (Err21) 0: Free stop 1: Stop by stop mode</p> <p>Hundreds place: Reserved</p> <p>Thousands place: Motor overheat (Err25) (the same ones place as F8-46)</p> <p>Ten thousands place: Runtime reach (Err26)( the same ones place as F8-46)</p>	00000	☆
F8-48	Fault protection selection 3	<p>Ones place: User-defined fault 1 (Err27) 0: Free stop 1: Stop by stop mode 2: Continue running</p> <p>Tens place: User-defined fault 2 (Err28) 0: Free stop 1: Stop by stop mode 2: Continue running</p> <p>Hundreds place: Power-on time reach (Err29) 0: Free stop 1: Stop by stop mode 2: Continue running</p> <p>Thousands place: load drop (Err30) 0: Free stop 1: Decel stop 2: Decelerates to 7% of the motor's rated frequency and continues to run, automatically resumes to the set frequency when no load drop</p> <p>Ten thousands place: PID feedback loses when running (Err31) 0: Free stop 1: Stop by stop mode 2: Continue running</p>	00000	☆

6. Functional parameter list

Function code	Item	Setting range	Factory default	Change
F8-49	Fault protection selection 4	Ones place: Speed deviation too large (Err42) 0: Free stop 1: Stop by stop mode 2: Continue running Tens place: Motor overspeed (Err43) (same as F8-46 ones place) Hundreds place: Initial position error (Err51) (same as F8-46 ones place) Thousands place: Reserved Ten thousands place: Reserved	00000	☆
F8-53	Selection of frequency to continue running when fault occurs	0: Run with the current freq. 1: Run with the set freq. 2: Run with the upper limit freq. 3: Run with the lower limit freq. 4: Run with the abnormal standby freq.	0	☆
F8-54	Abnormal standby freq.	0.0% ~ 100.0% (100% corresponds to max freq F0-07)	100.0%	☆
F8-55	Motor overheat protection threshold	0℃ ~ 200℃	110℃	☆
F8-56	Motor overheat warning threshod	0℃ ~ 200℃	90℃	☆
F8-57	Instant power-off action selection	0: Ineffective 1: Accel 2: Decel stop	0	☆
F8-58	Instant action pause judgment voltage	80.0%~100.0%	90.0%	☆
F8-59	Instant power-off voltage recovery judgment time	0.00s ~ 100.00s	0.50s	☆
F8-60	Instant power-off action judgment voltage	60.0%~100.0% (standard bus voltage)	80.0%	☆
F8-61	Load drop protection selection	0: Ineffective 1: Effective	0	☆
F8-62	Load drop detection level	0.0 ~ 100.0%	10.0%	☆
F8-63	Load drop detection time	0.0 ~ 60.0s	1.0s	☆
F8-65	Overspeed detection value	0.0% ~ 50.0% (max frequency)	20.0%	☆
F8-66	Overspeed detection time	0.0s ~ 60.0s	5.0s	☆
F8-67	Detection value when speed deviation is too large	0.0% ~ 50.0% (max frequency)	20.0%	☆
F8-68	Detection time when speed deviation is too large	0.0s ~ 60.0s	5.0s	☆
F8-69	Radiator's temp of inverter module	0.1℃		
F8-70	Radiator's temp of rectifier bridge	0.1℃		

## Group P: Operating panel's parameters

Function code	Item	Setting range	Factory default	Change
<b>P0: Universal keyboard's parameters</b>				
P0-00	MFK key's function selection	0: MFK ineffective 1: Switching between operation panel command channel and remote command channel (terminal command channel or comm. command channel) 2: Switching between FWD and REV 3: FWD jogging 4: REV jogging 5: Switching of modified parameter list	0	★
P0-01	Stop/reset key's function	0: Stop/reset key's stop function affects only in keyboard operation mode 1: Stop/reset key's stop function affects in any operation mode	1	☆
P0-02	Load speed display coefficient	0.0001 ~ 6.5000	1.0000	☆
P0-03	Load speed displays decimal places	0: 0 decimal place 1: 1 decimal place 2: 2 decimal places 3: 3 decimal places	1	☆
<b>P1: LED keyboard's parameters</b>				
P1-00	LED running display parameters 1	0000 ~ FFFF Bit00: Running frequency (Hz) Bit01: Set frequency (Hz) Bit02: Bus voltage (V) Bit03: Output voltage (V) Bit04: Output current (A) Bit05: Output power (kW) Bit06: Output torque (%) Bit07: DI input state Bit08: DO output state Bit09: AI1 voltage (V) Bit10: AI2 voltage (V) Bit11: AI3 voltage (V) Bit12: Count value Bit13: Length value Bit14: Load speed display Bit15: PID setting	H.001F	☆

6. Functional parameter list

Function code	Item	Setting range	Factory default	Change
P1-01	LED running display parameters 2	0000~FFFF Bit00: PID feedback Bit01: PLC stage Bit02: PULSE input pulse freq (kHz) Bit03: Running freq 2 (Hz) Bit04: Remaining runtime Bit05: AI1 pre-correction voltage (V) Bit06: AI2 pre-correction voltage (V) Bit07: AI3 pre-correction voltage (V) Bit08: Linear speed Bit09: Current power-on time (hour) Bit10: Current runtime (min) Bit11: PULSE input pulse freq (Hz) Bit12: Comm. set value Bit13: Encoder feedback speed (Hz) Bit14: Main freq. X display (Hz) Bit15: Aux freq. Y display (Hz)	H.0000	☆
P1-02	LED stop display parameters	0000~FFFF Bit00: Set frequency (Hz) Bit01: Bus voltage (V) Bit02: DI state Bit03: DO state Bit04: AI1 voltage (V) Bit05: AI2 voltage (V) Bit06: AI3 voltage (V) Bit07: Count value Bit08: Length value Bit09: PLC stage Bit10: Load speed Bit11: Pulse input freq. (kHz) Bit13-15: Reserved	H.0033	☆

6

**Group A: Application software's parameters**

Function code	Item	Setting range	Factory default	Change
<b>A0: Swing frequency, fixed length and count</b>				
A0-00	Swing frequency setting mode	0: Relative to the center freq. 1: Relative to the max freq.	0	☆
A0-01	Swing frequency amplitude	0.0% ~ 100.0%	0.0%	☆
A0-02	Startup frequency amplitude	0.0% ~ 50.0%	0.0%	☆
A0-03	Swing frequency period	0.1s ~ 3000.0s	10.0s	☆
A0-04	Triangular wave rise time of swing frequency	0.1% ~ 100.0%	50.0%	☆
A0-05	Fixed length	0m ~ 65535m	1000m	☆



Function code	Item	Setting range	Factory default	Change
A0-06	Actual length	0m ~ 65535m	0m	☆
A0-07	Pulse number per meter	0.1 ~ 6553.5	100.0	☆
A0-08	Set count value	1 ~ 65535	1000	☆
A0-09	Designated count value	1 ~ 65535	1000	☆
<b>A2: Virtual IO</b>				
A2-00	Virtual VDI1 terminal function selection	0 ~ 59	0	★
A2-01	Virtual VDI2 terminal function selection	0 ~ 59	0	★
A2-02	Virtual VDI3 terminal function selection	0 ~ 59	0	★
A2-03	Virtual VDI4 terminal function selection	0 ~ 59	0	★
A2-04	Virtual VDI5 terminal function selection	0 ~ 59	0	★
A2-05	Virtual VDI terminal state setting mode	Ones place: Virtual VDI1 0: Whether VDI is effective by the state of virtual VDOx 1: Whether VDI is effective by the setting of function code A2-06 Tens place: Virtual VDI2 (0 ~ 1) Hundreds place: Virtual VDI3 (0 ~ 1) Thousands place: Virtual VDI4 (0 ~ 1)	00000	★
A2-06	Virtual VDI terminal state setting	Ones place: Virtual VDI1 0: Ineffective 1: effective Tens place: Virtual VDI2 (0 ~ 1) Hundreds place: Virtual VDI3 (0 ~ 1) Thousands place: Virtual VDI4 (0 ~ 1) Ten thousands place: Virtual VDI5 (0 ~ 1)	00000	★
A2-07	Function selection when AI1 terminal serves as DI	0 ~ 59	0	★
A2-08	Function selection when AI2 terminal serves as DI	0 ~ 59	0	★
A2-09	Function selection when AI3 terminal serves as DI	0 ~ 59	0	★
A2-10	Effective mode selection when AI terminal serves as DI	0: High level effective 1: Low level effective Ones place: AI1 Tens place: AI2 Hundreds place: AI3	000	★

6. Functional parameter list

Function code	Item	Setting range	Factory default	Change
A2-11	Virtual VDO1 output function selection	0: Internal short circuit with physical Dix 1 ~ 41: See group F2 physical DO output selection	0	☆
A2-12	Virtual VDO2 output function selection	0: Internal short circuit with physical Dix 1 ~ 41: See group F2 physical DO output selection	0	☆
A2-13	Virtual VDO3 output function selection	0: Internal short circuit with physical Dix 1 ~ 41: See group F2 physical DO output selection	0	☆
A2-14	Virtual VDO4 output function selection	0: Internal short circuit with physical Dix 1 ~ 41: See group F2 physical DO output selection	0	☆
A2-15	Virtual VDO5 output function selection	0: Internal short circuit with physical Dix 1 ~ 41: See group F2 physical DO output selection	0	☆
A2-16	VDO1 output delay time	0.0s ~ 3600.0s	0.0s	☆
A2-17	VDO2 output delay time	0.0s ~ 3600.0s	0.0s	☆
A2-18	VDO3 output delay time	0.0s ~ 3600.0s	0.0s	☆
A2-19	VDO4 output delay time	0.0s ~ 3600.0s	0.0s	☆
A2-20	VDO5 output delay time	0.0s ~ 3600.0s	0.0s	☆
A2-21	VDO output terminal's effective state selection	Ones place: VDO1 0: Positive logic 1: Negative logic Tens place: Virtual VDO2 (0 ~ 1) Hundreds place: Virtual VDO3 (0 ~ 1) Thousands place: Virtual VDO4 (0 ~ 1) Ten thousands place: Virtual VDO5 (0 ~ 1)	00000	☆

**Group U: Optional card's parameters**

Function code	Item	Setting range	Factory default	Change
<b>U0: User-programmable card's parameters</b>				
U0-00	Comm. expansion card type	0: None 1: Profibus-DP comm. card 2: CANopen comm. Card 3: PLC card 4: PLC card ( Frequency given by MODBUS) 5: EtherCAT comm. Card	0	☆

Function code	Item	Setting range	Factory default	Change
U0-01	CANopen slave station address setting	1 ~ 63	1	☆
U0-02	Profibus slave station address setting	1 ~ 125	1	☆
U0-03	Control mode selection of control board's output terminal	0: Controlled by frequency converter 1: Controlled by user programmable control card Ones place: pulse (DO2 terminal serves as pulse output) Tens place: relay (TA-TB-TC) Hundreds place: DO1 Thousands place: on-off value (DO2 terminal serves as on-off output) Ten thousands place: AO1	00000	★
U0-05	Pulse output	0.0% ~ 100.0%	0.0%	☆
U0-06	AO1 output	0.0% ~ 100.0%	0.0%	☆
U0-07	On-off output	Binary system setting Ones place: on-off value Tens place: relay 1 Hundreds place: DO	001	☆

**Group d: Monitor parameters**

Function code	Item	Min unit	Comm. address
d0-00	Running frequency (Hz)	0.01Hz	7000H
d0-01	Set frequency (Hz)	0.01Hz	7001H
d0-02	Bus voltage (V)	0.1V	7002H
d0-03	Output voltage (V)	1V	7003H
d0-04	Output current (A)	0.01A	7004H
d0-05	Output power (kW)	0.1kW	7005H
d0-06	Output torque (%) motor rated percentage output value	0.1%	7006H
d0-07	DI state	1	7007H
d0-08	DO state	1	7008H
d0-09	AI1 voltage (V)	0.01V	7009H
d0-10	AI2 voltage (V)/current (mA)	0.01V/0.01mA	700AH
d0-11	AI3 voltage (V)	0.01V	700BH
d0-12	Count value	1	700CH
d0-13	Length value	1	700DH
d0-14	Load speed display	1	700EH
d0-15	PID setting	1	700FH
d0-16	PID feedback	1	7010H
d0-17	PLC stage	1	7011H
d0-18	PULSE input pulse frequency (Hz)	0.01kHz	7012H
d0-19	Feedback speed (Hz)	0.01Hz	7013H
d0-20	Remaining runtime	0.1min	7014H
d0-21	AI1 voltage before correction	0.001V	7015H

6. Functional parameter list

Function code	Item	Min unit	Comm. address
d0-22	AI2 voltage(V)/current (mA) before correction	0.001V/0.01mA	7016H
d0-23	AI3 voltage before correction	0.001V	7017H
d0-24	Linear speed	1m/min	7018H
d0-25	Current power-on time	1min	7019H
d0-26	Linear speed	0.1min	701AH
d0-27	Current power-on time	1Hz	701BH
d0-28	Comm. set value	0.01%	701CH
d0-29	Encoder feedback speed	0.01Hz	701DH
d0-30	Main freq. X display	0.01Hz	701EH
d0-31	Aux freq. Y display	0.01Hz	701FH
d0-32	Main freq. X display	1	7020H
d0-34	Aux freq. Y display	1℃	7022H
d0-35	Target torque (%)	0.1%	7023H
d0-36	Resolver position	1	7024H
d0-37	Power factor angle	0.1°	7025H
d0-38	ABZ position	1	7026H
d0-39	VF separation target voltage	1V	7027H
d0-40	VF separation output voltage	1V	7028H
d0-41	DI state visual display	1	7029H
d0-42	DO state visual display	1	702AH
d0-43	DI function state visual display1 (function 01-40)	1	702BH
d0-44	DI function state visual display2 (function 41-80)	1	702CH
d0-58	Z signal counter	1	703AH
d0-59	Set frequency (%)	0.01%	703BH
d0-60	Running frequency (%)	0.01%	703CH
d0-61	Frequency converter's state	1	703DH
d0-62	Current fault code	1	703EH
d0-63	Point-to-point comm. sending value	0.01%	703FH
d0-64	Number of slave station	1	7040H
d0-65	Upper limit of torque	0.01%	7041H
d0-66	Comm. expansion card model	100: CANOpen 200: Profibus-DP	7042H
d0-67	Comm. expansion card version	Display range	-
d0-68	DP card frequency converter's state	Bit0: Running state Bit1: Running direction Bit2: Does frequency converter fail? Bit3: Target frequency reach Bit4 ~ Bit7: Reserved Bit8 ~ Bit15: Fault code	7043H

## 7. Details of Parameters

### 7.1 Group b: System parameters

#### 7.1.1 b0: Basic system parameters

Function code	Item	Setting range	Factory default
b0-00	Access authority setting	0: Basic parameters 1: Standard parameters 2: Advanced parameters 3: Start parameters	0

The description of the function code is reference in the access authority setting.

Function code	Item	Setting range	Factory default
b0-01	Parameter initialization	0: No operation 1: Restore factory parameter, excluding motor's parameter 2: Clear record	0

1: Restore factory set value, excluding motor parameters.

After setting b0-01 to 1, most of the frequency converter's function parameters are restored to the factory default parameters, but the motor parameters, frequency command decimal point, fault record information, total running time, total power-on hours, and total power consumption are not restored.

2: Clear recorded information

Clear the frequency converter's fault recorded information, total runtime, total power-on hours, and total power consumption.

Function code	Item	Setting range	Factory default
b0-03	Function code's modification property	0: Modifiable 1: Non-modifiable	0

Whether the function code parameters can be modified to prevent the risk of the function parameter being mistakenly changed. When the function code is set to 0, all function codes can be modified; when set to 1, all function codes the only be viewed and cannot be modified.

Function code	Item	Setting range	Factory default
b0-04	Parameter copy	0: InEffective 1: Back up parameters to the operating panel 2: Copy parameters from the operating panel	0

b0-04 can realize the setting of function code for parameter copy.

0: The key does not function.

1: Back up the frequency converter's parameters to the operating panel. When the function code is set to 1, the word "copy" will appear on the operating panel, and the frequency converter's parameters will be copied to the operating panel.

2: Copy parameters from the operating panel to the frequency converter. When the function code

## 7. Details of Parameters

is set to 2, the word "load" will appear on the operating panel and the operating panel will be downloaded to the frequency converter.

Function code	Item	Setting range	Factory default
b0-05	User's password	0 ~ 65535	0

If b0-05 sets any non-zero number, the password protection function takes effect. When you enter the menu next time, you must enter the password correctly. Otherwise, you cannot view and modify the function parameters. Please remember the user password you set. Setting b0-05 to 00000 will clear the user password and invalidates the password protection function.

Function code	Item	Setting range	Factory default
b0-06	Total power-on hours	0h ~ 65535h	-

b0-06 shows the total power-on hours of the frequency converter since leaving the factory. When this time reaches the set power-on hours (F2-41), the frequency converter's multi-function digital output function (24) outputs the ON signal.

Function code	Item	Setting range	Factory default
b0-07	Total power consumption	0kW ~ 65535 kWh of electricity	-

It displays the total power consumption of the frequency converter so far.

Function code	Item	Setting range	Factory default
b0-08	Total running hours	0h ~ 65535h	-

It display the total runtime of the frequency converter.

When the runtime reaches F2-42 set runtime, the frequency converter's multi-function digital output function (12) outputs the ON signal.

Function code	Item	Setting range	Factory default
b0-09	Product number	-	-
b0-10	Software version	-	-

b0-09 and b0-10 respectively display the product number and software version number of the frequency converter.

## 7.2 Group C: Power control parameters

### 7.2.1 C0: Power control parameters

Function code	Item	Setting range	Factory default
C0-01	Selection of motor	0: Motor 1 1: Motor 2 2: Motor 3 3: Motor 4	0

XFC550 supports the application of frequency converter to drive 4 motors in time-share. 4 motors allow the setting of motor nameplate parameters, independent parameter tuning, selection of different control modes, and independently setting of parameters related to running performance.

The motor parameter group 1 corresponds to the function parameter group C1, the motor parameter group 2 corresponds to the function parameter group C2, the motor parameter group 3 corresponds to the function parameter group C3, and the motor parameter group 4 corresponds to the function parameter group C4.

The user can select the current motor parameter group through the C0-01 function code, and can also switch the motor parameters through the digital input terminal DI. When the function code selection conflicts with the terminal selection, the terminal selection shall prevail.

Function code	Item	Setting range	Factory default
C0-02	SVC optimal mode selection	0: No optimization 1: Optimal mode 1 2: Optimal mode 2	1

Asynchronous motor SVC optimization mode generally does not need to be adjusted.

Function code	Item	Setting range	Factory default
C0-03	Carrier frequency	0.5kHz ~ 16.0kHz	Dependent on model

This function is used to adjust the carrier frequency of the frequency converter. By adjusting the carrier frequency, the motor noise can be reduced to avoid the resonance point of the mechanical system and reduce the line-to-ground leakage current and the interference generated by the frequency converter. When the carrier frequency is low, high-order harmonic component of the output current increases, the motor loss increases, and the motor temperature rise increases. When the carrier frequency is much higher, the motor loss reduces and the motor temperature rise reduces, but the frequency converter loss increases, the temperature rise of the frequency converter increases, and the interference increases.

Adjusting the carrier frequency has the following effects:

Carrier frequency	Low → High
Motor noise	Large → Small
Output current wave form	Bad → Good
Motor's temp rise	High → Low
Frequency converter's temp rise	Low → High
Leakage current	Small → Large
Radiation interference	Small → Large

The factory setting of the carrier frequency is different for frequency converters with different powers.

## 7. Details of Parameters

Although the user can modify it according to needs, it should be noted that if the carrier frequency is set higher than the factory value, the temperature rise of the frequency converter's radiator will increase. At this time, the user needs to derate the frequency converter, otherwise the frequency converter has the risk of overheating alarm.

Function code	Item	Setting range	Factory default
C0-04	Carrier frequency adjusted along with temperature	0: No 1: Yes	1

The carrier frequency being adjusted along with temperature means that when the frequency converter detects that its own radiator temperature is high, it automatically reduces the carrier frequency to reduce the temperature rise of the frequency converter. When the radiator's temperature is low, the carrier frequency gradually restores to the set value. This feature reduces the chance of the drive overheating alarm.

Function code	Item	Setting range	Factory default
C0-05	DPWM switches upper limit frequency	0.00Hz ~ 15.00Hz	12.00Hz

Only valid for VF control. The wave-forming mode of the asynchronous motor running in VF mode determines that below this value is the 7-segment continuous modulation mode, and the opposite is the 5-segment intermittent modulation mode. In the 7-segment continuous modulation, the frequency converter has a large switching loss, but the current ripple is small; in the 5-segment intermittent debugging mode, the switching loss is small and the current ripple is large; but high frequency may lead to instable operation of the motor, which generally does not need to be modified. Please refer to function code C1-63 for instability in VF operation mode. For function loss and temperature rise, please refer to function code C0-03.

Function code	Item	Setting range	Factory default
C0-06	PWM modulation mode	0: Asynchronous 1: Synchronous	0

Only valid for VF control. Synchronous modulation means that the carrier frequency changes linearly with the output frequency to ensure that the ratio (carrier ratio) of the two is constant. It is generally used when the output frequency is high, which is beneficial to the output voltage quality. At lower output frequency (below 100 Hz), synchronous modulation is generally not required because the ratio of carrier frequency to output frequency is higher at this time, and the advantage of asynchronous modulation is more obvious. When the running frequency is higher than 85Hz, the synchronous modulation takes effect, and the frequency below is fixed the asynchronous modulation mode.

Function code	Item	Setting range	Factory default
C0-07	Random PWM depth	0: Random PWM inEffective 1 ~ 10: PWM carrier freq. random depth	0

By setting a random PWM, the harsh motor sound can be softened and it can help reduce electromagnetic interference. When the random PWM depth is set to 0, the random PWM is invalid. Adjusting the random PWM to different depths will have different effects.

Function code	Item	Setting range	Factory default
C0-08	Fast current limit enable	0: Disenable 1: Enable	1



Enable the fast current limiting function to minimize the overcurrent fault of the frequency converter and ensure the uninterrupted operation of the frequency converter. If the frequency converter continues to be in the fast current limit state for a long time, the frequency converter may be damaged by overheating. This situation is not allowed. Therefore, the alarm fault Err40 will appear when the frequency converter is quickly limited for a long time. At this time, the frequency converter is overloaded and needs to be stopped.

Function code	Item	Setting range	Factory default
C0-09	Current detection compensation	0 ~ 100	5

It is used to set the current detection compensation of the frequency converter. If the setting is too large, the control performance may be degraded. Generally it needs not to be modified.

Function code	Item	Setting range	Factory default
C0-10	Undervoltage point setting	60.0% ~ 140.0%	100.00%

It is used to set the voltage value of the frequency converter's undervoltage fault Err09. The factory value is related to the model.

Voltage class: 3-phase 380V

Undervoltage point: 350V

Function code	Item	Setting range	Factory default
C0-11	Cooling fan control	0: Fan works during running 1: Fan always works	0

It is used to select the operation mode of the cooling fan. When 0 is selected, the cooling fan works when the frequency converter is in the running state. If the radiator's temperature is higher than 40°C in the shutdown state, the cooling fan will work. When the radiator is below 40°C in the shutdown state, the cooling fan will not work. When 1 is selected, the cooling fan keeps working after power on.

Function code	Item	Setting range	Factory default
C0-12	Selection of dead zone compensation mode	0: No compensation 1: Compensation mode 1 2: Compensation mode 2	1

This parameter generally does not need to be modified. Only when there is a special requirement for the quality of the output voltage waveform, or when the motor has an abnormality such as oscillation, it is necessary to try to select different compensation modes.

Function code	Item	Setting range	Factory default
C0-13	Dead zone time adjustment	100% ~ 200%	150%

Only valid for 1140V voltage level. Adjusting this value can improve the effective voltage usage. If the adjustment is too small, the system may be unstable. User's modification is not recommended.

Function code	Item	Setting range	Factory default
C0-15	Motor overload warning coefficient	50% ~ 100%	80%

It displays the motor overload warning coefficient, which can effectively protect the motors of different loads.

## 7. Details of Parameters

Function code	Item	Setting range	Factory default
C0-16	Type of motor's temperature sensor	0: No temperature sensor 1: PT100 2: PT1000	0

The temperature signal of the motor temperature sensor needs to be connected to the multi-function I/O expansion card. This card is an optional accessory. The analog input AI3 of the expansion card can be used as the motor temperature sensor input, and the motor temperature sensor signal is connected to the AI3 and PGND terminals. The analog input AI3 of the XFC550 supports both PT100 and PT1000 motor temperature sensors. The sensor type must be set correctly when being used. The motor temperature value is displayed in d0-34.

### 7.2.2 C1: The 1st motor's parameters

Function code	Item	Setting range	Factory default
C1-00	Motor type Selection	0: Common asynchronous motor 1: Variable frequency asynchronous motor	0
C1-01	Motor's rated power	0.1kW ~ 1000.0kW	Dependent on model
C1-02	Motor's rated voltage	1V ~ 2000V	Dependent on model
C1-03	Motor's rated current	0.01A ~ 655.35A (power of frequency converter ≤ 55kW) 0.1A ~ 6553.5A (power of frequency converter > 55kW)	Dependent on model
C1-04	Motor's rated frequency	0.01Hz ~ max frequency	Dependent on model
C1-05	Motor's rated speed	1rpm ~ 65535rpm	Dependent on model

The above function code is the motor's nameplate parameter. Regardless of whether VF control or vector control is used, the relevant parameters need to be accurately set according to the motor's nameplate. In order to obtain better VF or vector control performance, motor parameter tuning is required, and the accuracy of the adjustment result is closely related to the correct setting of the motor's nameplate parameters.

Function code	Item	Setting range	Factory default
C1-06	Asynch motor's stator resistance	0.001Ω ~ 65.535Ω (power of frequency converter ≤ 55kW) 0.0001Ω ~ 6.5535Ω (power of frequency converter > 55kW)	Tuning parameter
C1-07	Asynch motor's rotor resistance	0.001Ω ~ 65.535Ω (power of frequency converter ≤ 55kW) 0.0001Ω ~ 6.5535Ω (power of frequency converter > 55kW)	Tuning parameter
C1-08	Leakage reactance of asynch motor	0.01mH ~ 655.35mH (power of frequency converter ≤ 55kW) 0.001mH ~ 65.535mH (power of frequency converter > 55kW)	Tuning parameter

Function code	Item	Setting range	Factory default
C1-09	Mutual inductive reactance (asynchronous motor)	0.1mH ~ 6553.5mH (power of frequency converter<=55kW) 0.01mH ~ 655.35mH (power of frequency converter>=55kW)	Tuning parameter
C1-10	No-load current of asynchronous motor	0.01A ~ C1-03 (power of frequency converter<=55kW) 0.1A ~ C1-03 (power of frequency converter>=55kW)	Tuning parameter

C1-06 ~ C1-10 are the parameters of the asynchronous motor. These parameters are generally not printed on the motor's nameplate and need to be automatically tuned by the frequency converter. Among them, "asynchronous motor static tuning" can only obtain three parameters C1-06 ~ C1-08, and "asynchronous motor dynamic tuning" can obtain encoder's phase sequence and current loop PI in addition to all five parameters.

When changing the motor's rated power (C1-01) or the motor's rated voltage (C1-02), the frequency converter will automatically modify the C1-06 ~ C1-10 parameter values and restore these five parameters to the common standard Y series motor's parameters.

If the asynchronous motor cannot be tuned at the site, the corresponding function code can be input according to the parameters provided by the motor manufacturer.

Function code	Item	Setting range	Factory default
C1-27	Encoder lines	1 ~ 65535	1024

Set the number of pulses per revolution of the ABZ or UVW incremental encoder.

In the speed sensor's vector control mode, the encoder pulse number must be set correctly, otherwise the motor will not operate normally.

Function code	Item	Setting range	Factory default
C1-28	Encoder type	0: ABZ incremental encoder 1: UVW incremental encoder 2: Rotary transformer 3: Sine and cosine encoder 4: Line-saving UVW encoder	0

The XFC550 supports a variety of encoder types. Different encoders need to be equipped with different PG cards. Please select the correct PG card when being used. Asynchronous motors generally use only ABZ incremental encoders and resolvers. After installing the PG card, set C1-28 correctly according to the actual situation, otherwise the frequency converter may not operate normally.

7

Function code	Item	Setting range	Factory default
C1-30	ABZ phase sequence of ABZ encoder	0: Forward 1: Reverse	0

This function code is valid only for the ABZ incremental encoder, that is, only when C1-28=0.

Used to set the phase sequence of the ABZ incremental encoder's AB signal.

The function code is valid for the asynchronous motor. When the asynchronous motor is dynamically tuned, the phase sequence of the ABZ encoder's AB signal can be obtained.

## 7. Details of Parameters

Function code	Item	Setting range	Factory default
C1-31	UVW encoder's mounting angle	0.0 ~ 359.9°	0.0°
C1-32	UVW phase sequence of ABZ encoder	0: Forward 1: Reverse	0
C1-33	UVW encoder's offset angle	0.0 ~ 359.9°	0.0°
C1-34	Number of pole pairs of resolver	1 ~ 65535	1

As the resolver has pole pairs, when using this encoder, the pole pair parameters must be set correctly.

Function code	Item	Setting range	Factory default
C1-36	Speed feedback PG broken line detecting time	0.0: No action 0.1s~10.0s	0.0

It is used to set the detection time of the encoder's disconnection fault. When set to 0.0s, the frequency converter does not detect the encoder's disconnection fault. When the frequency converter detects a disconnection fault and the duration exceeds the C1-36 set time, the frequency converter alarms and displays Err20.

Function code	Item	Setting range	Factory default
C1-37	Tuning selection	0: No operation 1: Static tuning of asynchronous motor 2: Complete tuning of asynchronous motor	0

In order to ensure the optimal control performance of the frequency converter in vector control mode, please disconnect the load from the motor and use the rotary tuning to self-learn the motor parameters, otherwise the vector control will be affected.

Before the parameter's self-learning, the motor's type and nameplate parameters C1-00~C1-05 must be correctly set. For the closed-loop vector control, the encoder's type and pulse number C1-27 and C1-28 should be additionally set.

Description of tuning: Set the motor's nameplate parameters and self-learning type, then press the RUN key, the frequency converter will perform static tuning.

0: No operation, namely tuning is forbidden.

1: Asynchronous motor's static tuning.

Applicable to asynchronous motors and where large inertia loads are not easily disconnected and cannot be tuned for rotation.

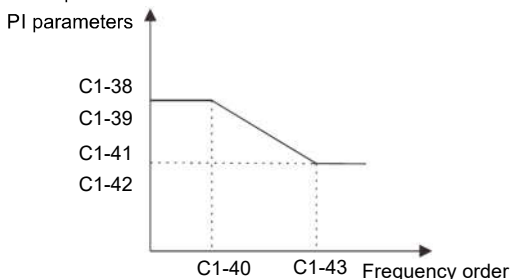
2. Asynchronous motor's dynamic tuning.

During the dynamic tuning process, the frequency converter first performs static tuning, and then accelerates to 80% of the rated motor frequency according to the acceleration time F0-39. After a period of time, the frequency converter decelerates to stop according to the deceleration time F0-40 and ends the tuning.

Note: Tuning supports motor tuning in keyboard operating mode, terminal mode, and communication mode.

Function code	Item	Setting range	Factory default
C1-38	Speed loop proportional gain 1	1 ~ 100	30
C1-39	Speed loop integral time 1	0.01s ~ 10.00s	0.50s
C1-40	Switchover frequency 1	0.00 ~ C1-43	5.00Hz
C1-41	Speed loop proportional gain 2	1 ~ 100	20
C1-42	Speed loop integral time 2	0.01s ~ 10.00s	1.00s
C1-43	Switchover frequency 2	C1-40 ~ max frequency	10.00Hz

The frequency converter runs at different frequencies and can select different speed loop PI parameters. When the running frequency is less than the switching frequency 1 (C1-40), the speed loop PI adjustment parameters are C1-38 and C1-39. When the running frequency is greater than the switching frequency 2, the speed loop PI adjustment parameters are C1-41 and C1-42. The speed loop PI parameter between the switching frequencies 1 and 2 is linearly switched between the two sets of PI parameters, as the picture shows:



**Fig. 7-1 Diagram of PI parameters**

The speed dynamic response characteristic of the vector control can be adjusted by setting the proportionality factor and the integral time of the speed regulator. Increasing the proportional gain and reducing the integral time can speed up the dynamic response of the speed loop. However, if the proportional gain is too large or the integral time is too less, the system may produce oscillation. The recommended adjustment method: if the factory default parameters cannot meet the requirements, then carry out fine-tuning based on the factory default parameters. First increase the proportional gain to ensure that the system does not oscillate, then reduce the integral time, so that the system has faster response characteristics.

Note: If the PI parameters are not set properly, the speed overshoot may be too large. An overvoltage fault occurs even when the overshoot falls back.

Function code	Item	Setting range	Factory default
C1-44	Vector control slip gain	50% ~ 200%	100%

For vector control without speed sensor, this parameter is used to adjust the motor's steady speed accuracy: when the motor is loaded and runs at a low speed, increase the parameter, and vice versa. For vector control with speed sensor, this parameter can adjust the output current of the frequency converter under the same load.

Function code	Item	Setting range	Factory default
C1-45	Speed loop filter time constant	0.000s ~ 0.100s	0.000s

## 7. Details of Parameters

SVC speed feedback filtering time is only effective when C1-61=0. Increasing C1-45 can improve the stability of the motor, but the dynamic response becomes weaker. Otherwise, the dynamic response is strengthened, but too small will cause the motor to oscillate. Under normal circumstances, no adjustment is required.

Function code	Item	Setting range	Factory default
C1-47	Torque's upper limit source in speed control mode	0: Function code C1-48 setting 1: AI1 2: AI2 3: AI3 4: PULSE setting 5: Communication reference 6: MIN (AI1,AI2) 7: MAX (AI1,AI2) The full range of 1 ~ 7 correspond to C1-48	0
C1-48	Torque's upper limit digit setting in speed control mode	0% ~ 200.0%	150%

In the speed control mode, the maximum value of the frequency converter's output torque is controlled by the torque upper limit source. C1-47 is used to select the setting source of the upper torque limit. When the analog quantity, pulse, and communication are set, the corresponding set 100% corresponds to C1-48, and 100% of C1-48 corresponds to Rated output current of the frequency converter.

The AI1, AI2, and AI3 settings are described in the AI curve (the respective curves are selected by F1-23). The pulse is described in F1-18~F1-22. If the communication is set to the point-to-point communication slave and the received data is used as the torque reference, the torque digital setting is sent directly by the host. See the group U1 point-to-point communication introduction. Otherwise, the host computer writes 100.00%~100.00% of the data through the communication address 0x1000, of which 100.00% corresponds to C1-48.

Support MODBUS, CANopen and Profibus-DP

Function code	Item	Setting range	Factory default
C1-51	Excitation adjustment proportional gain	0 ~ 60000	2000
C1-52	Excitation adjustment integral gain	0 ~ 60000	1300
C1-53	Torque adjustment proportional gain	0 ~ 60000	2000
C1-54	Torque adjustment integral gain	0 ~ 60000	1300

The vector-control current loop PI adjustment parameter is automatically obtained after the asynchronous motor is dynamically tuned, and generally does not need to be modified. It needs to be reminded that the integral regulator of the current loop does not use the integral time as the dimension, but directly sets the integral gain. The current loop PI gain setting being too large may cause the entire control loop to oscillate, so when the current oscillates or torque fluctuation is large, the PI proportional gain or integral gain can be manually reduced.

Function code	Item	Setting range	Factory default
C1-61	The first motor's control mode	0: No-speed sensor vector control 1: Speed sensor vector control 2: V/F control	2

0: The vector control without speed sensor refers to open-loop vector control, which is suitable for normal high-performance control applications. One frequency converter cthe ONLY drive one motor. It is usually used for motors to drive machine tools, centrifuges, wire drawing machines, injection molding machines and other loads.

1: Vector control with speed sensor refers to closed-loop vector control. The motor must be equipped with an encoder and the frequency converter must be equipped with the same type of PG card as the encoder. It is suitable for high precision speed control or torque control applications. One frequency converter the only drive one motor. It is usually used for motors to drive high-speed paper machinery, lifting machinery, elevators and other loads.

2: V/F control. Applicable to occasions where the load requirements are not high, or when one frequency converter drives multiple motors, such as fans and pumps. It can be used in the case where one frequency converter drives multiple motors.

Tip: The motor's parameter tuning process must be performed when the vector control mode is selected. Only accurate motor parameters can give the full play to vector control. Better performance can be achieved by adjusting the speed regulator parameter group C1 function code (2nd is group C2).

Function code	Item	Setting range	Factory default
C1-62	Torque boost	0.0%: (Automatic torque boost) 0.1% ~ 30.0%	Dependent on model

In order to compensate the low-frequency torque characteristics of V/F control, some boost compensation is applied to the frequency converter output voltage at low frequencies. However, if the torque boost setting is too large, the motor is prone to overheating, and the frequency converter is prone to overcurrent. It is recommended to increase this parameter when the load is heavy and the motor starting torque is insufficient. The torque boost can be reduced when the load is light. When the torque boost is set to 0.0, the automatic torque boost is enabled. At this time, the frequency converter automatically calculates the required torque boost value according to parameters such as the stator resistance of the motor.

Function code	Item	Setting range	Factory default
C1-63	VF oscillation suppression gain	0 ~ 100	Dependent on model

The selection method of the gain is as small as possible under the premise of effectively suppressing the oscillation, so as to avoid adversely affecting the operation of the VF. Select this gain to be 0 when there is no oscillation in the motor. Only when the motor oscillates obviously, the gain needs to be appropriately increased. The larger the gain, the more obvious the suppression of the oscillation. When the suppression oscillation function is used, the motor's rated current and no-load current parameters are required to be accurate, otherwise the VF oscillation suppression effect is not good.

### 7.2.3 C2、C3、C4: The 2nd, 3rd and 4th motor's parameters

XFC550 can run for 4 motors through switching. For the 4 motors, the motor's nameplate parameters can be separately set, parameter tuning can be separately performed, VF control or vector control can be selected separately, encoder related parameters can be set separately, and VF control or vector control performance related parameters can be set separately. The function codes of C2, C3, and C4 correspond to all parameters of the motor 2, 3, 4, groups C2, C3, and C4. The definition and usage method are consistent with the relevant parameters of the first motor. You can refer to the description of the parameters related to the 1st motor. The acceleration/deceleration time of the 2nd, 3rd, and 4th motors is different. For details, please refer to the description of corresponding function code.

### 7.2.4 C5: V/F control parameters

This group of function codes is valid only for V/F control and invalid for vector control. V/F control is suitable for general-purpose loads such as fans and pumps, or one frequency converter drives multiple motors, or applications where the frequency converter's power and motor's power are quite different.

Function code	Item	Setting range	Factory default
C5-00	V/F curve setting	0: Linear V/F 1: Multipoint V/F 2: Square V/F 3:1.2nd power V/F 4:1.4th power V/F 6: 1.6th power V/F 8: 1.8th power V/F 10: VF complete separation mode 11: VF semi-separation mode	0

0: Linear V/F is suitable for ordinary constant torque loads.

1: Multi-point V/F is suitable for special loads such as dehydrators and centrifuges. Under this mode, an random VF relationship curve can be obtained by setting the C5-02~C5-07 parameters.

2: Square V/F is suitable for centrifugal loads such as fans and pumps.

3~8: VF relationship curve between linear VF and square VF.

10: VF complete separation mode. Under this mode, the output frequency of the frequency converter is independent of the output voltage. The output frequency is determined by the frequency source, and the output voltage is determined by C5-10 (VF separation voltage source). VF complete separation mode is generally used in induction heating, reverse power supply, torque motor control and other occasions.

11: VF semi-separation mode. In this case, V is proportional to F, but the proportional relationship can be set by voltage source C5-10, and the relationship between V and F is also related to the motor's rated voltage and rated frequency of group C1. Assuming that the voltage source input is X (X is a value of 0~100%), the relationship between the frequency converter output voltage V and the frequency F is:  $V/F=2*X$  (motor's rated voltage) / (motor's rated frequency)

Function code	Item	Setting range	Factory default
C5-01	Cutoff freq. of torque boost	0.00Hz ~ max frequency	50.00Hz



Torque cutoff frequency of torque boost: At this frequency, the torque boost is valid. If the set frequency is exceeded, the torque boost will be invalid, as shown in Fig. 7-2.

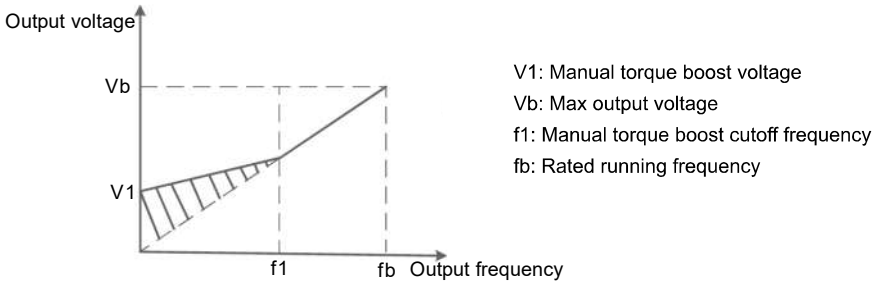


Fig. 7-2 Diagram of manual torque boost

Function code	Item	Setting range	Factory default
C5-02	Multipoint VF freq. point 1	0.00Hz ~ C5-04	0.00Hz
C5-03	Multipoint VF voltage point 1	0.0% ~ 100.0%	0.0%
C5-04	Multipoint VF freq. point 2	C5-02 ~ C5-06	0.00Hz
C5-05	Multipoint VF voltage point 2	0.0% ~ 100.0%	0.0%
C5-06	Multipoint VF freq. point 3	C5-04 ~ C1-04	0.00Hz
C5-07	Multipoint VF voltage point 3	0.0% ~ 100.0%	0.0%

C5-02 ~C5-07 six parameters define multistage V/F curve.

The multi-point V/F curve should be set according to the load characteristics of the motor. It should be noted that the relationship between the three voltage points and the frequency point must satisfy:  $V1 < V2 < V3$ ,  $F1 < F2 < F3$ . Figure 7-3 shows the setting of the multi-point V/F curve. If the voltage is set too high at low frequencies, the motor may overheat or even burn out, leading to over-speed or over-current protection.

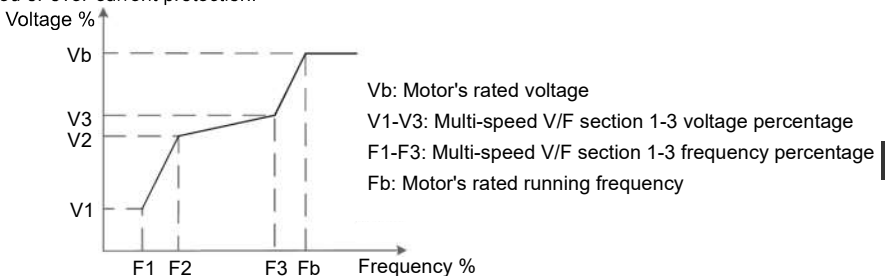


Fig. 7-3 Diagram of multi-point V/F curve setting

Function code	Item	Setting range	Factory default
C5-08	VF slip freq. comp. gain	0.0% ~ 200.0%	0.0%

This parameter is only valid for asynchronous motor.

VF slip compensation can compensate the motor's speed deviation generated by the asynchronous motor when the load increases, so that the motor's speed can be basically kept stable when the load changes.

## 7. Details of Parameters

When the VF slip compensation gain is set to 100.0%, it means that the compensated slip is the motor's rated slip when the rated load is applied to the motor, and the rated slip of the motor is obtained by the frequency converter's rated frequency and speed of the motor of group C1. When adjusting the VF slip compensation gain, the motor speed is basically the same as the target speed under the rated load. When the motor speed is different from the target value, the gain needs to be fine-tuned appropriately.

Function code	Item	Setting range	Factory default
C5-09	VF overexcitation gain	0 ~ 200	64

During the deceleration of the frequency converter, the overexcitation control can suppress the rise of the bus voltage and avoid overvoltage faults.

The larger the overexcitation gain, the stronger the suppression effect. In the case where the frequency converter is easy to overvoltage alarm during the deceleration process, it is necessary to increase the overexcitation gain.

However, if the overexcitation gain is too large, it will easily lead to an increase in the output current, which needs to be weighed in the application.

For applications where the inertia is small, there is no voltage rise during motor deceleration. It is recommended to set the overexcitation gain to zero. In the case of a braking resistor is used, it is also recommended to set the overexcitation gain to zero.

Function code	Item	Setting range	Factory default
C5-10	Voltage source of VF separation	0: digit setting (C5-11) 1: AI1 2: AI2 3: AI3 4: PULSE setting (D15) 5: multistage command 6: simple PLC 7: PID 8: Communication setting Note: 100.0% corresponds to motor's rated voltage	0
C5-11	Voltage digital setting of VF separation	0V ~ motor's rated voltage	0V

VF separation is generally used in applications such as induction heating, frequency converter power supply and torque motor control.

When VF separation control is selected, the output voltage can be set by function code C5-11, or it can be from analog quantity, multi-segment instruction, PLC, PID or communication reference.

When non-digital setting is used, 100% of each setting corresponds to the rated voltage of the motor. When the percentage of the output setting such as analog quantity is negative, the set absolute value is used as the effective setting value.

0: Digital setting (C5-11). The voltage is set directly by C5-11. The VF separation voltage source selection is similar to the frequency source selection. See description of "F0-01 Main Frequency Source Selection." Among them, the 100.0% of the various types of selection corresponds to the rated voltage of the motor (the absolute value of the corresponding setting is selected).

Function code	Item	Setting range	Factory default
C5-12	Voltage rising time of VF separation	0.0s ~ 1000.0s Note: It means the time that 0V rises to the motor's rated voltage	0.0s

The voltage rise time of Vf separation refers to the time required for the output voltage to accelerate from 0 to the rated voltage of the motor, see t1 in the figure.

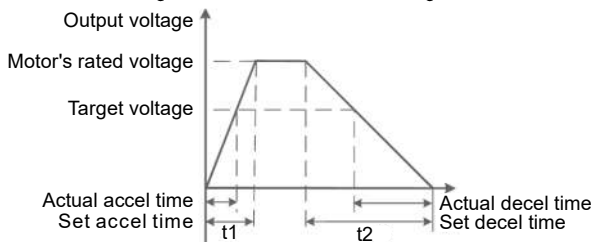


Fig. 7-4 V/F Diagram of separation

## 7.2.5 Vector control parameters

Function code	Item	Setting range	Factory default
C6-00	Speed/torque control mode selection	0: Speed control 1: Torque control	0

It is used to select the frequency converter's control mode: speed control or torque control. Note: The control mode cannot be switched through this function code during frequency converter's operation.

The XFC550's multi-function digital DI terminal has two functions related to torque control: torque control disabled (Function 29) and speed control/torque control switching (Function 46). These two terminals are required to be used in conjunction with the C6-00 to achieve the switching between speed control and torque control. When the switching between speed control and torque control terminal is invalid, the control mode is determined by C6-00. If the switching between speed control and torque control is valid, the control mode is equivalent to the inverse of the value of C6-00. In any case, when the torque control disabling terminal is valid, the frequency converter is fixed to the speed control mode.

Function code	Item	Setting range	Factory default
C6-01	Selection of torque setting source in torque control mode	0: digit setting 1 (C6-03) 1: AI1 2: AI2 3: AI3 4: PULSE 5: Communication reference 6: MIN (AI1,AI2) 7: MAX (AI1,AI2) (The full range of 1 ~ 7 corresponds to digit setting of C6-03)	0
C6-03	Torque digit setting in torque control mode	-200.0% ~ 200.0%	150.0%

C6-01 is used to select the torque setting source. The torque setting uses the relative value, and

## 7. Details of Parameters

---

100.0% corresponds to the motor's rated torque. The setting range is -200.0%~200.0%, which indicates that the maximum torque of the frequency converter is 2 times the rated torque of the frequency converter. When the torque is given as positive, the frequency converter runs forward. When the torque is given negative, the frequency converter runs reversely and the torque setting sources are described as follows:

- 0: Digital setting (C6-03) refers to the target torque directly using the C6-03 setting.
- 1: AI1
- 2: AI2
- 3: AI3

It refers that the target torque is determined by the analog input terminal.

The XFC550 control board provides two analog input terminals (AI1, AI2), and the optional I/O expansion card provides an additional analog input terminal (AI3). AI1 provides voltage input of 0V~10V and AI2 provides voltage input of 0V~10V or current input of 0mA~20mA, which is selected by X501[1] jumper on the control board. AI3 provides voltage input of -10V~10V. The input voltage value of AI1, AI2, and AI3, and the corresponding relationship with the target torque, can be freely selected through F1-23.

XFC550 provides 5 sets of correspondence curves, among which 3 sets of curves are linear relationships (2 points correspondence), and 2 sets of curves are arbitrary curves of 4 points correspondence. Users can conduct the setting through function codes F1-25~F1-41 and F1-42~F1-71. Function code F1- 23 is used to set the three-way analog input of AI1~AI3, and select which of the five sets of curves. When AI is used as the frequency reference, the voltage/current input corresponds to the set value of 100.0%, which refers to the percentage of the relative torque digital setting of C6-03.

- 4: Pulse setting(DI5)

The target torque reference is given by the high speed pulse of terminal DI5. Pulse reference signal specifications: voltage range 9V~30V and frequency range 0.00kHz~100.00kHz. The pulse reference can only be input from the multi-function input terminal DI5. The relationship between the input pulse frequency of the DI5 terminal and the corresponding setting is set by F1- 18~F1-21. The corresponding relationship is the linear correspondence of 2 points. The corresponding input of the pulse input is 100.0%, which refers to the percentage of the relative torque digital setting of C6-03.

- 5: Communication reference

It refers to that the target torque is given by the communication mode. When it is a point-to-point communication slave and receives data as a torque reference, the host is used to transmit the data as the communication reference (see the group U1 for instructions). When Profibus-DP and CANOpen communication are valid and PZD1 is used as the frequency reference, the data value transmitted by PZD1 is directly used at the time, and the range is -F0-07~+F0-07. When Modbus communication is used, the host computer gives the data by the communication address 0x1000. The data format is data with 2 decimal places, and the data range is -F0-07~+F0-07.

For example, when PZD1 (X1000) is 5000, namely it is 50.00Hz; when PZD1 is -5000, namely it is -50.00Hz.

The communication card must be installed when communication is used. The XFC550's 4 communication cards are optional. Users can choose according to their needs. If the communication protocol is Modbus-RTU, Profibus-DP or CANopen, you need to select the corresponding serial communication according to U0-00. protocol.

Function code	Item	Setting range	Factory default
C6-05	Forward max freq. of torque control	0.00Hz ~ max frequency	50.00Hz
C6-06	Reverse max freq. of torque control	0.00Hz ~ max frequency	50.00Hz

In torque control mode, the acceleration/deceleration time of the upper frequency limit is set at F0-45 (acceleration)/F0-46 (deceleration).

It is used to set the forward or reverse maximum running frequency of the frequency converter under the torque control mode.

In torque control mode of the frequency converter, if the load torque is less than the motor output torque, the motor speed will continue to rise. To prevent accidents such as free-running in the mechanical system, the maximum motor speed during torque control must be limited.

If you need to achieve dynamic continuous change of the torque control maximum frequency, you can make it by controlling the upper limit frequency.

Function code	Item	Setting range	Factory default
C6-07	Torque control accel time	0.00s ~ 650.00s	0.00s
C6-08	Torque control decel time	0.00s ~ 650.00s	0.00s

In the torque control mode, the difference between the motor output torque and the load torque determines the speed change rate of the motor and the load. Therefore, the motor speed may change rapidly, causing problems such as excessive noise or mechanical stress.

By setting the torque control acceleration/deceleration time, the motor speed can be changed gently.

In the torque control of small torque start, it is not recommended to set the torque acceleration/deceleration time; if the torque acceleration/deceleration time is set, it is recommended to increase the speed filter coefficient appropriately; if the torque is required to respond quickly, set the torque control acceleration/deceleration time to 0.00s.

For example, two motors are hard-wired to drive the same load. To ensure uniform load distribution, one frequency converter is set as the master, the speed control mode is adopted, and the other frequency converter is the slave and the torque control is used. The actual output torque acts as the torque command of the slave. At this time, the torque of the slave needs to follow the master quickly, then the torque control acceleration/deceleration time of the slave is 0.00s.

## 7.3 Group F: Function control parameters

### 7.3.1 F0: Control and set parameters

Function code	Item	Setting range	Factory default
F0-00	Selection of command source	0: Operating panel's command channel (REMOTE OFF) 1: Terminal command channel (REMOTE ON) 2: Comm command channel (REMOTE FLASHING)	0

Select the input channel for the drive control command. The frequency converter's control commands include start, stop, forward, reverse, jog, etc.

0: Operating panel's command channel ("REMOTE" indicator is OFF)

Run command control is performed by the run key and stop key button on the operation panel.

1: Terminal command channel ("REMOTE" indicator is ON)

Run command control is performed by multi-function input terminals FWD, REV, JOGF, JOGR, etc.

2: Communicaiton command channel ("REMOTE" indicator is flashing)

The run command is given by the host computer through communication.

When this option is selected, communication (Modbus-RTU, Profibus-DP card, user programmable control card or CANopen card, etc.) must be selected.

When the communication mode is Profibus-DP and the PZD1 data is valid, the frequency converter's control command is given by the PZD1 data.

In other cases, the control command is written by address 0x2000. The control command is defined in Appendix A Communication Protocol.

Additional instructions for the communication card are distributed with the communication card, and a brief description of the communication card is included in the appendix to this manual.

Function code	Item	Setting range	Factory default
F0-01	Main frequency source X selection	0: Digit setting (preset frequency F0-06, UP/DOWN modifiable, no memory when power off) 1: Digit setting (preset frequency F0-06, UP/DOWN modifiable, memory when power off) 2: AI1 3: AI2 4: AI3 5: PULSE setting (DI5) 6: Multistage command 7: Simple PLC 8: PID 9: Communication setting	1

Select the input channel for the main frequency of the frequency converter. There are 10 main reference frequency channels:

0: digital setting (No memory when power off)

Set the initial value of the frequency to the value of F0-06 "Preset Frequency". The set frequency value of the frequency converter can be changed by turning shuttle on the keyboard. When the frequency converter is powered on again after power-off, the set frequency value is restored to the value of F0-06 "digital set preset frequency".

1: Digital setting (Memory when power-down)

Set the initial value of the frequency to the value of F0-06 "Preset Frequency". The set frequency value of the frequency converter can be changed by turning shuttle on the keyboard. When the frequency converter is powered off and then powered on again, the set frequency is the set frequency at the last power-off, and the correction value is recorded by turning the shuttle key on the keyboard or UP/DOWN of the terminal. It needs to remind that F0-15 is "Digital Set Frequency Stop Memory Selection" which is used to select whether the frequency correction value is memorized or cleared when the frequency converter is stopped. F0-15 is related to shutdown and is not related to memory when power-down. It needs to be noted in application.

2: AI1

3: AI2

4: AI3

It refers that the frequency is determined by the analog input terminal. The XFC550 control board provides two analog input terminals (AI1, AI2), and the optional I/O expansion card provides an additional analog input terminal (AI3). AI1 provides voltage input of 0V~10V and AI2 provides voltage input of 0V~10V or current input of 0mA~20mA, which is selected by X501[1] jumper on the control board. AI3 provides voltage input of -10V~10V. The input voltage value of AI1, AI2, and AI3, and the corresponding relationship with the target torque, can be freely selected through F1-23.

XFC550 provides 5 sets of correspondence curves, among which 3 sets of curves are linear relationships (2 points correspondence), and 2 sets of curves are arbitrary curves of 4 points correspondence. Users can conduct the setting through function codes F1-25~F1-41 and group F1 of function codes. Function code F1- 23 is used to set the three-way analog input of AI1~AI3, and select which of the five sets of curves. When AI is used as the frequency reference, the voltage/current input corresponds to the set value of 100.0%, which refers to the percentage of the relative torque digital setting of F0-07.

5: Pulse (DI5)

The frequency reference is given by the high speed pulse of terminal DI5. Pulse reference signal specifications: voltage range 9V~30V and frequency range 0.00kHz~100.00kHz. The pulse reference can only be input from the multi-function input terminal DI5. The relationship between the input pulse frequency of the DI5 terminal and the corresponding setting is set by F1- 18~F1-21. The corresponding relationship is the linear correspondence of 2 points. The corresponding input of the pulse input is 100.0%, which refers to the percentage of the relative torque digital setting of F0-07.

6: Multi-stage command

When the multi-stage command operation mode is selected, it is necessary to input combinations of different states by DI terminals to correspond to different set frequency values.

## 7. Details of Parameters

XFC550 can provide 4 multi-stage command terminals (terminal functions 12~15), 16 states of 4 terminals, and can correspond to any 16 "multi-stage instructions" through group F4 of function code. "Multi-stage command" is the percentage of relative maximum frequency F0-07. When D1 terminal is used as the multi-stage command terminal, it needs to be set in the group F1. For details, please refer to the description of group F1's related function parameters.

### 7: Simple PLC

When the simple PLC serves the frequency source, the running frequency source of the frequency converter can be switched between 1~16 arbitrary frequency commands. The holding time of 1~16 frequency commands and the respective acceleration/deceleration time can also be set by the user. See the description of the group F4 for details.

### 8: PID

The output of the process PID control is selected as the operating frequency. Generally it is used for on-site process closed-loop control, such as constant voltage closed-loop control, constant voltage closed-loop control and other applications. When PID is used as the frequency source, you need to set the parameters related to the "PID function" of the group F5.

9: The communication reference refers to that the frequency is given by the communication method.

When Modbus communication is used, the data is given by the host computer through the communication address 0x1000. The data format is -100.00%~100.00%, and 100.00% refers to the percentage of the relative maximum frequency F0-07.

Function code	Item	Setting range	Factory default
F0-02	Auxiliary frequency source Y selection	Same as F0-01 (main frequency source X selection)	0

When the auxiliary frequency source is used as the independent frequency reference channel (that is, the frequency source is selected as X to Y switching), its usage is the same as that of the main frequency source X. For the usage, refer to the related description of F0-01.

Function code	Item	Setting range	Factory default
F0-03	Range selection of auxiliary frequency source Y when superposing	0: Relative to max frequency 1: Relative to frequency source X	0
F0-04	Range of auxiliary frequency source Y when superposing	0% ~ 150%	100%

When the frequency source is selected as "frequency superposition", these two parameters are used to determine the adjustment range of the auxiliary frequency source. F0-03 is used to determine the object corresponding to the range of the auxiliary frequency source. It can be selected relative to the maximum frequency or relative to the main frequency source X. If it is selected relative to the main frequency source, the range of the auxiliary frequency source will vary with the main frequency X.



Function code	Item	Setting range	Factory default
F0-05	Frequency source superposition selection	Ones place: Frequency source selection 0: Main frequency source X 1: Main and auxiliary operation result (operation relation is determined by tens place) 2: Switch between main frequency source X and auxiliary frequency source Y 3: Switch between main frequency source X and main & auxiliary operation results 4: Switch between auxiliary frequency Source Y and main & auxiliary operation results Tens place: Main & auxiliary operation relation of frequency source 0: Main + Auxiliary 1: Main – Auxiliary 2: Max value of the two 3: Min value of the two	00

The frequency reference channel is selected by this parameter. The frequency reference is achieved by a combination of the main frequency source X and the secondary frequency source Y. When the frequency source is selected as the main and auxiliary operation, the offset frequency can be set by F0-13, and the offset frequency is superimposed on the main and auxiliary operation results to flexibly respond to various requirements.

Function code	Item	Setting range	Factory default
F0-06	Preset frequency	0.00Hz ~ max frequency (F0-07)	50.00Hz

When the frequency source is selected as “digital setting”, the function code value is the initial value of the frequency digital setting of the frequency converter.

Function code	Item	Setting range	Factory default
F0-07	Max frequency	50.00Hz ~ 500.00Hz	50.00Hz

In the XFC550, the analog input, pulse input (DI5), multi-stage command, etc. as the frequency source, each 100.0% is scaled relative to F0-07.

Function code	Item	Setting range	Factory default
F0-08	Upper limit frequency source	0: F0-09 setting 1: AI1 2: AI2 3: AI3 4: PULSE setting 5: Communication reference	0

Define the source of the upper limit frequency.

The upper limit frequency can be set by the digital setting (F0-09), the analog input, PULSE setting or communication reference. When analog (AI1, AI2, AI3) setting, PULSE setting (DI5) or communication setting are used, it is similar to the main frequency source, see F0-01.

## 7. Details of Parameters

For example, when the torque control mode is adopted in the winding control site, the upper limit frequency can be set by analog to avoid the “free-running” due to material disconnection. When the frequency converter runs to the upper limit frequency value, it keeps running at the upper limit frequency.

Function code	Item	Setting range	Factory default
F0-09	Upper limit frequency	Lower limit frequency F0-11 ~ max frequency F0-07	50.00Hz

Set the upper limit frequency with the range of F0-11~F0-07.

Function code	Item	Setting range	Factory default
F0-10	Upper limit frequency offset	0.00Hz ~ max frequency F0-07	0.00Hz

When the upper limit frequency source is set to analog or PULSE setting, F0-07 is used as the offset of the set value, and F0-08 sets the upper limit frequency value to be added as the set value of the final upper limit frequency.

Function code	Item	Setting range	Factory default
F0-11	Lower limit frequency	0.00Hz ~ upper limit frequency F0-09	0.00Hz

When the frequency command is lower than the lower limit frequency set by F0-11, the frequency converter can stop, run at the lower limit frequency or run at zero speed. The running mode can be set by F0-24 to set the frequency lower than the lower limit frequency.

Function code	Item	Setting range	Factory default
F0-13	Auxiliary freq. source's offset frequency in superimposing	0.00Hz ~ max frequency F0-07	0.00Hz

This function code is valid only when the frequency source is selected as the main and secondary operations. When the frequency source is the main and auxiliary operation, F0-13 is used as the offset frequency, and is superimposed with the result of the main and auxiliary operations as the final frequency setting value, so that the frequency setting can be more flexible.

Function code	Item	Setting range	Factory default
F0-15	Digital setting frequency shutdown memory selection	0: No memory 1: Memory	1

This function is valid only when the frequency source is digitally set. “No memory” means that the digital set frequency value returns to the value of F0-06 (preset frequency) after the frequency converter stops, and the correction value is cleared by the turning the shuttle key on the keyboard or the use of UP/DOWN of the terminal. “Memory” means that the digital set frequency remains the set frequency of the last stop after the frequency converter stops. The frequency correction by the turning the shuttle key on the keyboard or the use of UP/DOWN of the terminal remains valid.

Function code	Item	Setting range	Factory default
F0-16	Frequency command UP/DOWN reference when running	0: Running frequency 1: Set frequency	0

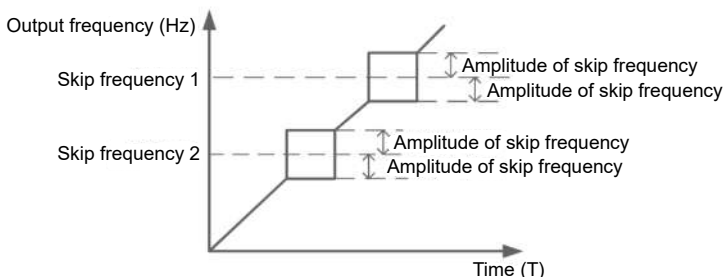
This parameter is valid only when the frequency source is digitally set. When the shuttle key on the keyboard is turned or the terminal UP/DOWN is used, for which method is used to correct the set frequency, that is, whether the target frequency increases or decreases based on the operating frequency or increases or decreases based on the set frequency.

The difference between the two settings is obvious when the frequency converter is in the acceleration/deceleration process. That is, if the running frequency of the frequency converter is different from the set frequency, the different choices of the parameters vary greatly.

Function code	Item	Setting range	Factory default
F0-17	Command source's bound frequency source	Ones place: Operating panel command binds frequency source selection 0: No binding 1: Digital set frequency 2: AI1 3: AI2 4: AI3 5: PULSE setting (DI5) 6: Multistage speed 7: Simple PLC 8: PID 9: Communication setting Tens place: Terminal command binds frequency source selection Hundreds place: Comm. Command binds frequency source selection Thousands place: Auto run binds frequency source selection	0000

Defining the binding combination between the four running command channels and the nine frequency reference channels facilitates synchronous switching. The above frequency reference channel has the same meaning as F0-01 the main frequency source X selection. Please refer to the description of F0-01 function code. Different running command channels can bind the same frequency reference channel. When the command source has a bound frequency source, the frequency source set by F0-01~F0-05 will no longer function during the valid period of the command source.

Function code	Item	Setting range	Factory default
F0-18	Skip frequency 1	0.00Hz ~ max frequency	0.00Hz
F0-19	Skip frequency 2	0.00Hz ~ max frequency	0.00Hz
F0-20	Amplitude of skip frequency	0.00Hz ~ max frequency	0.01Hz



**Fig. 7-5 Diagram of skip frequency**

When the set frequency is within the skip frequency range, the actual operating frequency will run at a skip frequency that is closer to the set frequency. By setting the skip frequency, the frequency converter can be avoided from the mechanical resonance point of the load. The XFC550 can have two

## 7. Details of Parameters

skip frequency points. If both skip frequencies are set to 0, the skip frequency function is canceled. Whether the jump frequency is valid during acceleration/deceleration is related to the F0-50 function code setting. The principle of the skip frequency and the skip frequency amplitude is shown in Figure 7-5.

Function code	Item	Setting range	Factory default
F0-21	Running direction	0: Same direction 1: Opposite direction	0

By changing the function code, the purpose of changing the motor steering can be realized without changing the motor wiring. The function is equivalent to adjusting any two wires of the motor (U, V, W) to realize the rotation direction of the motor.

Tip: After the parameters are initialized, the motor running direction will return to the original state. It is better not to be used when changing the direction of the motor after the system is commissioned.

Function code	Item	Setting range	Factory default
F0-22	FWD/REV dead zone time	0.0s ~ 3000.0s	0.0s

Set the transition time at the output 0Hz during the forward/reverse transition of the frequency converter, as shown in Figure 7-6.

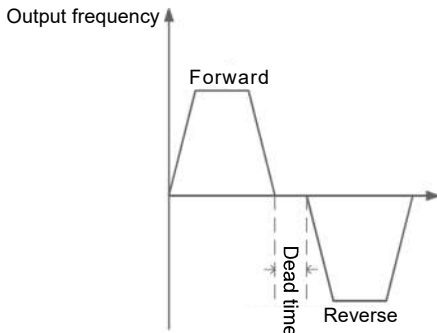


Fig. 7-6 Diagram of dead time of FWD and REV run

Function code	Item	Setting range	Factory default
F0-23	REV control enable	0: Enable 1: Disenable	0

When the frequency given by "Communication Reference" or "Analog Reference" is negative, the motor's running direction will change, which is called "reverse frequency". This parameter allows you to set whether the frequency converter allows the motor to run in the reverse state. When the motor is not allowed to run in reverse, set F0-23=1; when F0-23=0 is set, the motor is allowed to run in reverse.

Function code	Item	Setting range	Factory default
F0-24	Operation mode that set frequency lower than the lower limit frequency	0: Run with lower limit frequency. 1: Shutdown 2: Run at zero speed	0

When the set frequency is lower than the lower limit frequency, the running status of the frequency converter can be selected by this parameter. The XFC550 offers three running modes to meet a variety of application needs.

Function code	Item	Setting range	Factory default
F0-25	Drop control	0.00Hz ~ 10.00Hz	0.00Hz

The droop rate allows for a slight speed difference between the master station and the slave station, which in turn avoids conflicts between them. The default value for this parameter is 0. Only when the speed control mode is adopted by both the master and the slave, it is necessary to adjust the droop rate. For each transmission process, the appropriate droop rate needs to be gradually found in practice. It is recommended not to set F0-25 too large, otherwise when the load is too large, the steady-state speed will drop significantly.

Both the master and the slave must have a droop rate. Drooping speed = synchronization frequency x output torque x droop rate/10

For example: F0-25= 1.00, synchronous frequency 50Hz, output torque 50%, then

Drooping speed=50Hzx50%x1.00/10=2.5Hz

Actual frequency=50Hz - 2.5Hz = 47.5Hz

Function code	Item	Setting range	Factory default
F0-26	Start mode	0: Direct start 1: Speed tracking restart 2: Pre-excitation start (AC asynch motor)	0

0: Direct start

If the start DC braking time is set to 0, the frequency converter will start running from the starting frequency. If the DC braking time is not 0, the DC braking is performed first, and then the starting frequency is started.

For small inertia loads, the motor may rotate when starting.

1: Speed-tracking start

The frequency converter first judges the speed and direction of the motor, and then starts with the tracked motor frequency, and implements a smooth and non-impact start for the rotating motor. It is suitable for Instantaneous power failure restart for large inertia loads. In order to ensure the performance of the speed tracking restart, it is necessary to accurately set the motor group C1 parameters.

2: Asynchronous motor's pre-excitation start

It is only valid for asynchronous motors, used to establish a magnetic field before the motor is running. Pre-excitation current and time are described in function codes F0-31 and F0-30. If the pre-excitation time is set to 0, the frequency converter cancels the pre-excitation process and starts with the start frequency.

If the pre-excitation time is not 0, the motor will be pre-excited before restart, which can improve the dynamic response performance of the motor.

Function code	Item	Setting range	Factory default
F0-27	Start protection selection	0: No protection 1: Protection	0

This parameter relates to the safety protection function of the frequency converter. When the parameter is set to 1, if the frequency converter's running command when powered on is valid (for example, the terminal running command is closed before power-on), the frequency converter does not respond to the running command, and the running command must be cancelled once. The frequency converter will respond when the running command is valid again.

## 7. Details of Parameters

In addition, when the parameter is set to 1, if the frequency converter's running command is valid at fault reset time, the frequency converter does not respond to the running command, and the running command must be cancelled first to eliminate the running protection state. Setting this parameter to 1 prevents the danger of the motor responding to the running command when power is on or when the fault is reset without knowing it.

Function code	Item	Setting range	Factory default
F0-28	Start frequency	0.00Hz ~ 10.00Hz	0.00Hz
F0-29	Start frequency holding time	0.0s ~ 100.0s	0.0s

To ensure motor torque at start-up, please set the appropriate starting frequency. In order to fully establish the magnetic flux when the motor is started, the starting frequency needs to be maintained for a certain period of time. The starting frequency F0-28 is not limited by the lower limit frequency. However, when the set target frequency is less than the start frequency, the frequency converter does not start and is in the standby state. The starting frequency holding time does not work during the forward and reverse switching. Starting frequency holding time is not included in the acceleration time, but is included in the run time of the simple PLC.

Example: F0-01 = 0 frequency source is digital reference

F0-06 = 2.00Hz digital set frequency is 2.00Hz

F0-28 = 5.00Hz starting frequency is 5.00Hz

F0-29 = 2.0s starting frequency holding time is 2.0s

At this point, the frequency converter will be in standby mode and its output frequency is 0.00Hz.

Example 2: F0-01=0 frequency source is digital reference

F0-06= 10.00Hz digital setting frequency is 10.00Hz

F0-28=5.00Hz starting frequency is 5.00Hz

F0-29=2.0s starting frequency holding time is 2.0 s

At this point, the frequency converter accelerates to 5.00 Hz, and after 2.0s, it accelerates to a given frequency of 10.00 Hz.

Function code	Item	Setting range	Factory default
F0-30	Start DC braking time/pre-excitation time	0.0s ~ 100.0s	0.0s
F0-31	Start DC braking current/pre-excitation current	0% ~ 100%	0%

Start DC braking is generally used to stop the running motor and then restart.

The pre-excitation is used to first activate the asynchronous motor to establish a magnetic field, thereby improving the response speed.

Start DC braking is only effective when the startup mode is direct start. At this time, the frequency converter first performs DC braking according to the set start DC braking current, and then starts running after the DC braking time. If the DC braking time is set to 0, it will start directly without DC braking. The greater the DC braking current, the greater the braking force. If the starting mode is pre-excitation start for asynchronous motor, the frequency converter first establishes the magnetic field according to the preset pre-excitation current, and then starts running after the set pre-excitation time.

If the pre-excitation time is set to 0, it will start directly without the pre-excitation process. To start DC braking current Pre-excitation current, there are two cases relative to the base value. When the rated current of the motor is less than or equal to 80% of the rated current of the frequency converter, it is the base value relative to the rated current of the motor; when the rated current of the motor is greater than 80% of the rated current of the frequency converter, it is the rated current of the frequency converter relative to 80% of the percentage base value.

Function code	Item	Setting range	Factory default
F0-32	Stop mode	0: Decel stop 1: Free stop 2: Positioning stop	0

0: Decel stop

After the stop command is valid, the frequency converter reduces the output frequency according to the deceleration time, and stops after the frequency drops to zero.

1: Free stop

After the stop command is valid, the frequency converter immediately terminates the output, and the motor is free to stop according to the mechanical inertia.

2: Positioning stop

Positioning stop needs to cooperate with stopping DC braking function. The frequency converter is deceleration stopping, running frequency arrives the starting frequency(F0-33) of stopping DC braking function. The frequency converter keeps the starting frequency of stopping DC braking function. When the position signal is effective, DC braking process starts.

Function code	Item	Setting range	Factory default
F0-33	Initial frequency of stop DC braking	0.00Hz ~ max frequency	0.00Hz
F0-34	Stop DC braking waiting time	0.0s ~ 100.0s	0.0s
F0-35	Stop DC braking time	0.0s ~ 100.0s	0.0s
F0-36	Stop DC braking current	0% ~ 100%	0%

DC braking start frequency at stop: During the deceleration stop, when the running frequency is reduced to this frequency, the DC braking process starts.

DC brake waiting time at stop: After the running frequency is reduced to the stop DC braking start frequency, the frequency converter stops output for a period of time before starting the DC braking process.

It is used to prevent malfunctions such as overcurrent that may be caused by starting DC braking at higher speeds.

DC braking time at stop: The time during which the DC braking amount is maintained. This value is 0 and the DC braking process is cancelled.

DC braking current at stop: DC braking current at stop, there are two cases relative to the base value.

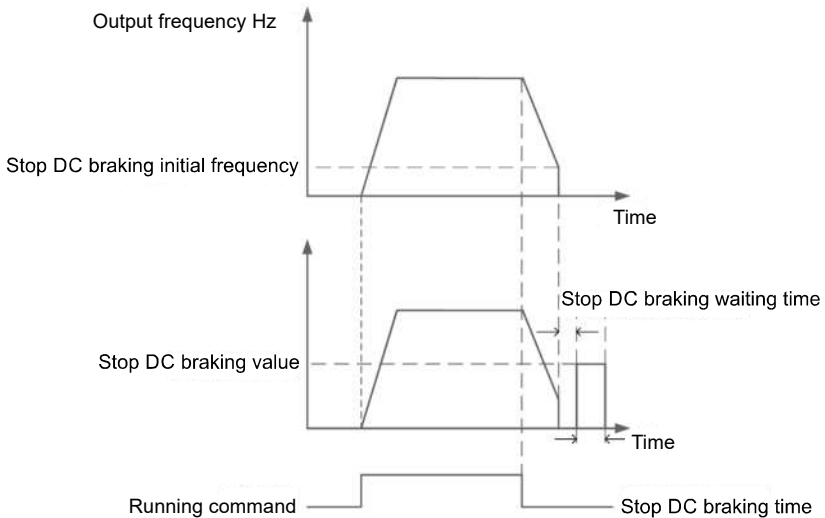
1. When the rated current of the motor is less than or equal to 80% of the rated current of the frequency converter, it is the base value relative to the rated current of the motor;

2. When the rated current of the motor is greater than 80% of the rated current of the frequency

## 7. Details of Parameters

converter, it is the rated current of the frequency converter relative to 80% of the percentage base value.

The DC braking process at stop is shown in the figure below:



**Fig. 7-7 Diagram of DC braking process at stop**

Function code	Item	Setting range	Factory default
F0-37	Acceleration-deceleration time unit	0: 1s 1: 0.1s 2: 0.01s	1

To meet the needs of various types of applications, the XFC550 offers three acceleration and deceleration time units of 1 second, 0.1 second and 0.01 second.

Note: When modifying the function parameters, the number of decimal points displayed in the 4 groups of acceleration/deceleration time will change, and the corresponding acceleration/deceleration time will also change. Please pay special attention during the application process.

Function code	Item	Setting range	Factory default
F0-38	Acceleration-deceleration time base frequency	0: Max frequency (F0-07) 1: Set frequency 2: 100.00Hz	0

Acceleration/deceleration time refers to the acceleration/deceleration time from zero frequency to the frequency set by F0-38. Figure 7-8 shows the acceleration/deceleration time. When F0-38 is selected as 1, the acceleration/deceleration time is related to the set frequency. If the set frequency changes frequently, the acceleration of the motor changes, so pay attention to the this in application.

Function code	Item	Setting range	Factory default
F0-39	Acceleration time 1	0.00s ~ 650.00s (F0-37=2) 0.0s ~ 6500.0s (F0-37=1) 0s ~ 65000s (F0-37=0)	Dependent on model
F0-40	Deceleration time 1	Same as F0-39	Dependent on model



Acceleration time refers to the time required for the frequency converter to accelerate from zero frequency to the acceleration/deceleration reference frequency (determined by F0-38), see  $t_1$  in Figure 7-8. Deceleration time refers to the time required for the frequency converter to decelerate to zero frequency from the acceleration/deceleration reference frequency (determined by F0-38), see  $t_2$  in Figure 7-8.

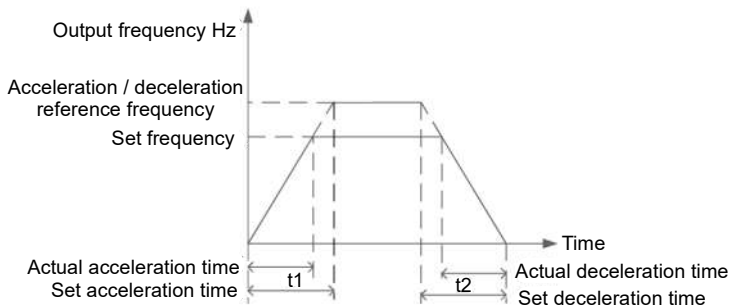


Fig. 7-8 Diagram of acceleration/deceleration time

Function code	Item	Setting range	Factory default
F0-41	Acceleration time 2	0.0s ~ 6500.0s	Dependent on model
F0-42	Deceleration time 2	0.0s ~ 6500.0s	Dependent on model
F0-43	Acceleration time 3	0.0s ~ 6500.0s	Dependent on model
F0-44	Deceleration time 3	0.0s ~ 6500.0s	Dependent on model
F0-45	Acceleration time 4	0.0s ~ 6500.0s	Dependent on model
F0-46	Deceleration time 4	0.0s ~ 6500.0s	Dependent on model

The XFC550 provides four sets of acceleration and deceleration time, including F0-39 and F0-40 and the above three sets of acceleration and deceleration time. The definition of the four groups of acceleration and deceleration time is exactly the same, please refer to the instructions of F0-39 and F0-40. Through the different combinations of the multi-function digital input terminals DI, you can switch between 4 groups of acceleration/deceleration time. For details, please refer to the related instructions in function codes F1-01 ~ F1-05.

Function code	Item	Setting range	Factory default
F0-47	Acceleration/deceleration mode	0: Linear acceleration/deceleration 1: S curve acceleration/deceleration A 2: S curve acceleration/deceleration B	0

Select the way the frequency change of the frequency converter during start and stop.

0: Linear acceleration/deceleration

The output frequency is linearly incremented or decremented by. The XFC550 offers four acceleration and deceleration times. It can be selected through the multi-function digital input terminals (F1-00 ~ F1-09).

## 7. Details of Parameters

### 1: S curve acceleration/deceleration A

In the case where the target frequency is fixed, the output frequency is incremented or decremented according to the S curve. It is suitable for applications where gentle start or stop is required, such as elevators and conveyor belts.

### 2: S curve acceleration/deceleration B

In the case of real-time dynamic changes in the target frequency, the output frequency is incremented or decremented in real time according to the S curve. It is suitable for occasions where the comfort requirements are high and the real-time response is fast.

Note: S-curve acceleration/deceleration B time and target frequency should not be too large, acceleration/deceleration time is greater than 100s or target frequency is greater than 6 times. Several rated frequencies start S-curve acceleration/deceleration B is invalid, and automatically switches to linear acceleration/deceleration mode.

Function code	Item	Setting range	Factory default
F0-48	S curve beginning-segment time proportion	0.0% ~ (100.0%-F0-49)	30.00%
F0-49	S curve ending-segment time proportion	0.0% ~ (100.0%-F0-48)	30.00%

The function codes F0-48 and F0-49 respectively define the ratio of the initial stage and the end stage time of the S-curve acceleration/deceleration A. The two function codes should satisfy:  $F0-48 + F0-49 \leq 100.0\%$ . In Figure 7-9,  $t_1$  is the parameter defined by parameter F0-48. During this period, the slope of the output frequency changes gradually.  $T_2$  is the time defined by parameter F0-49, during which the slope of the output frequency change gradually changes to zero. During the time between  $t_1$  and  $t_2$ , the slope of the output frequency change is fixed, that is, the interval is linearly accelerated or decelerated.

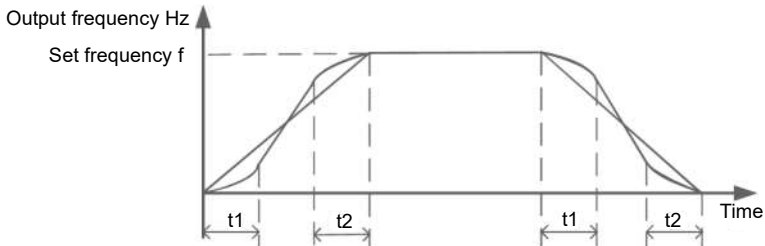


Fig. 7-9 Diagram of S-curve acceleration/deceleration A

Function code	Item	Setting range	Factory default
F0-50	Jump frequency during acceleration/deceleration	0: Ineffective 1: Effective	0

This function code is used to set whether the skip frequency is valid during acceleration and deceleration. If set to valid, when the running frequency is in the skip frequency range, the actual running frequency will skip over the set skip frequency boundary. Figure 7-10 shows the effective skip frequency during acceleration and deceleration.

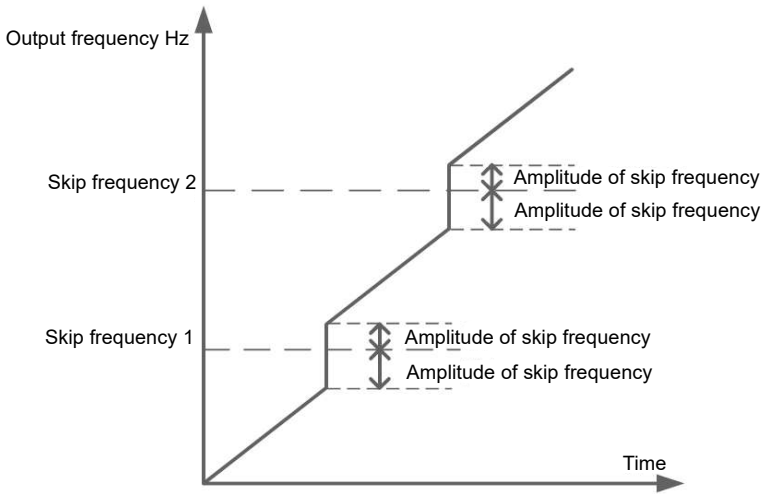


Fig. 7-10 Diagram of Effective skip frequency during acceleration and deceleration

Function code	Item	Setting range	Factory default
F0-53	Frequency switchover point between acceleration time 1 and acceleration time 2	0.00Hz ~ max frequency	0.00Hz
F0-54	Frequency switchover point between deceleration time 1 and deceleration time 2	0.00Hz ~ max frequency	0.00Hz

This function is valid when the motor 1 is selected and the acceleration/deceleration time is not selected by DI terminal switching. It is used to select different acceleration/deceleration time according to the running frequency range without going through the DI terminal during the running of the frequency converter.

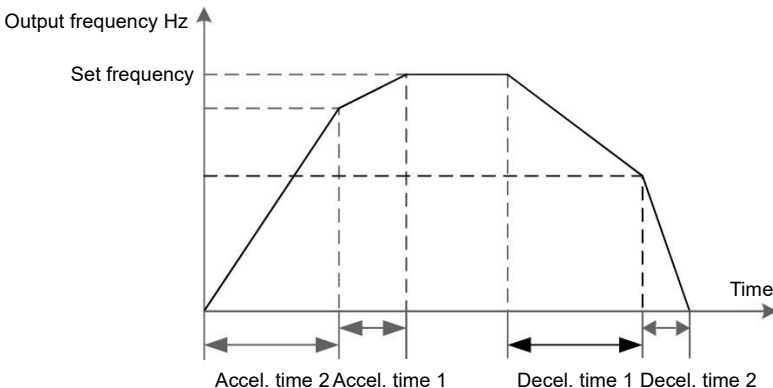


Fig. 7-11 Diagram of acceleration/deceleration time switching

## 7. Details of Parameters

During the acceleration process, if the running frequency is less than F0-53, select the acceleration time 2; if the running frequency is greater than F0-53, select the acceleration time 1. During deceleration, if the running frequency is greater than F0-54, select the deceleration time 1. If the running frequency is less than F0-54, select the deceleration time 2.

Function code	Item	Setting range	Factory default
F0-55	Terminal jogging priority	0: InEffective 1: Effective	0

This parameter is used to set whether the terminal jog function has the highest priority.

When the terminal jog priority is valid, if the terminal jog command appears during operation, the frequency converter switches to the terminal jog operation state.

Function code	Item	Setting range	Factory default
F0-56	Jogging running frequency	0.00Hz ~ max frequency	2.00Hz
F0-57	Jogging acceleration time	0.0s ~ 6500.0s	20.0s
F0-58	Jogging deceleration time	0.0s ~ 6500.0s	20.0s

The given frequency and acceleration/deceleration time of the frequency converter when defining jogging.

When jog running, the start mode is fixed to the direct start mode (F0-26=0), and the stop mode is fixed to the deceleration stop (F0-32=0)

Function code	Item	Setting range	Factory default
F0-59	Speed tracking mode	0: Start from stop frequency 1: Start from zero 2: Start from max frequency	0

In order to complete the speed tracking process in the shortest time. Choose frequency converter to track motor speed.

0: This method is usually followed down from the frequency of power failure.

1: Start from zero, when power outage is longer and restart.

2: Tracking from the maximum frequency is generally the use of generating loads.

Function code	Item	Setting range	Factory default
F0-60	Speed tracking	1 ~ 100	20

In the speed tracking start, select the rate of the speed tracking.

The larger the parameter, the faster the tracking speed. However, setting too large may cause the tracking effect to be unreliable.

Function code	Item	Setting range	Factory default
F0-61	Brake rate	0% ~ 100%	100%

It is only valid for frequency converters with built-in brake unit. It is used to adjust the duty ratio of the brake unit. When the brake usage rate is high, the duty ratio of the brake unit is high and the braking effect is strong. However, the voltage of the frequency converter's bus voltage fluctuates greatly during the braking process.

### 7.3.2 F1: Input terminal's parameters

XFC550 series frequency converters are provided with 5 multi-function digital input terminals (DI5 can be used as high-speed pulse input terminal) and 2 analog input terminals. If the system needs more input and output terminals, you can choose multi-function input and output expansion card. The multi-function I/O expansion card has 5 multi-function digital input terminals (DI6–DI10) and 1 analog input terminal (AI3).

Function code	Item	Setting range	Factory default
F1-00	DI1 terminal's function selection	0: No function	1
F1-01	DI2 terminal's function selection	1: FWD running	4
F1-02	DI3 terminal's function selection	2: REV running	9
F1-03	DI4 terminal's function selection	3: Three-line running control	12
F1-04	DI5 terminal's function selection	4: FJOG	13
F1-05	DI6 terminal's function selection	5: RJOG	0
F1-06	DI7 terminal's function selection	6: Terminal UP	0
F1-07	DI8 terminal's function selection	7: Terminal DOWN	0
F1-08	DI9 terminal's function selection	8: Free stop	0
		9: Fault RESET	
		10: PAUSE	
		11: External fault's normally-open input	
		12: Multistage command terminal 1	
		13: Multistage command terminal 2	
		14: Multistage command terminal 3	
		15: Multistage command terminal 4	
		16: Acceleration/deceleration time selection terminal 1	
		17: Acceleration/deceleration time selection terminal 2	
		18: Switchover of frequency source	
		19: UP/DOWN setting clear (terminal and keyboard)	
		20: Running command switching terminal	
		21: Acceleration/deceleration forbidden	
		22: PID Pause	
		23: PLC Reset	
		24: Swing freq. pause	
		25: Counter input	
		26: Counter reset	
		27: Length count input	
		28: Length reset	
		29: Torque control forbidden	
		30: PULSE frequency input (Effective for DI5 only)	

7. Details of Parameters

Function code	Item	Setting range	Factory default
F1-09	DI10 terminal's function selection	32: Immediate DC brake 33: External fault's normally-close input 34: Frequency modification enable 35: PID acting direction reverse 36: External stop terminal 1 37: Control command switching terminal 2 38: PID integration pause 39: Switch between frequency source X and preset frequency 40: Switch between frequency source Y and preset frequency 41: Motor's selection terminal 1 42: Motor's selection terminal 2 43: PID parameters' switching 44: User's defined fault 1 45: User's defined fault 2 46: Switching between speed control and torque control 47: Emergency stop 48: External stop terminal 2 49: Decel DC braking 50: Current running hour clear 51: Location arrive input signal 52 ~ 59: Reserved	0

These parameters are used to set the function of the digital multi-function input terminal. The functions that can be selected are shown in the following table:

Set value	Function	Description
0	No function	The unused terminals can be set to "No function" to prevent malfunction.
1	FWD running	The inverter is controlled to rotate forward and reverse by external terminals.
2	REV running	
3	Three-line running control	It is determined by this terminal that the frequency converter operation mode is the three-wire control mode. For details, refer to the description of function code F1-16 ("Terminal Command Method").
4	FJOG	FJOG is jog forward run and RJOG is jog reverse run.
5	RJOG	Jog running frequency, jog acceleration/deceleration time, see function codes F0-56, F0-57 and F0-58
6	Terminal UP	The frequency increment and decrement instructions are modified when the frequency is given by the external terminal. When the frequency source is set to digital setting, the set frequency can be adjusted up and down.
7	Terminal DOWN	
8	Free stop	The frequency converter blocks the output, and the motor's stopping process is not controlled by the frequency converter. This mode has the same meaning as the free stop described in F0-32.

Set value	Function	Description
9	Fault RESET	The function of fault reset using the terminal. Same function as the RESET button on the keyboard. This function enables remote fault reset.
10	PAUSE	The frequency converter decelerates to stop, but all operating parameters are memorized. Such as PLC parameters, swing frequency parameters, PID parameters. After the terminal signal disappears, the frequency converter returns to the operating state before stopping.
11	External fault's normally-open input	When the signal is sent to the frequency converter, it reports the fault Err15 and performs fault processing according to the fault protection action mode (details participate in function code F8-46).
12	Multistage command terminal 1	The 16-stage speed or 16 other command settings can be made through the 16 states of these four terminals. See Table 1 for details.
13	Multistage command terminal 2	
14	Multistage command terminal 3	
15	Multistage command terminal 4	
16	Accel-decel time selection terminal 1	Four types of acceleration/deceleration time are selected by the four states of the two terminals. See Table 2 for details.
17	Accel-decel time selection terminal 2	
18	Switching of freq. source	Used to switch between different frequency sources. According to the setting of the frequency source selection function code (F0-05), when switching between two kinds of frequency sources is set as the frequency source, the terminal is used to switch between the two frequency sources.
19	UP/DOWN setting clear (terminal and keyboard)	When the frequency is given as the digital frequency, this terminal can clear the frequency value changed by the terminal UP/DOWN or the keyboard UP/DOWN, so that the given frequency returns to the value set by F0-06.
20	Control command switching terminal 1	When the command source is set to terminal control (F0-00=1), this terminal can switch between terminal control and keyboard control. When the command source is set to communication control (F0-00=2), this terminal can switch between communication control and keyboard control.
21	Accel-decel forbidden	Ensure that the frequency converter is not affected by external signals (except for shutdown commands) to maintain current output frequency.

7. Details of Parameters

Set value	Function	Description
22	PID Pause	The PID temporarily fails, the frequency converter maintains the current output frequency, and the PID adjustment of the frequency source is no longer performed.
23	PLC Reset	The PLC pauses during execution. When it runs again, the frequency converter can be restored to the initial state of the simple PLC through this terminal.
24	Swing freq. pause	The frequency converter outputs at the center frequency. The swing frequency function is suspended.
25	Counter input	Count the input terminals of the pulse.
26	Counter reset	The counter status is cleared.
27	Length count input	Input terminal for length counting.
28	Length reset	Length is cleared
29	Torque control forbidden	The frequency converter is prohibited from performing torque control, and the frequency converter enters the speed control mode.
30	PULSE freq. input (Effective for DI5 only)	DI5 functions as a pulse input terminal.
32	Immediate DC brake	When the terminal is valid, the frequency converter directly switches to the DC braking state.
33	External fault's normally-close input	When the external fault normally closed signal is sent to the frequency converter, it reports the fault Err15 and stops.
34	Freq. modification enable	If the DI1 terminal is valid, the frequency is allowed to be modified; if the DI1 terminal is invalid, the frequency modification is prohibited.
35	PID acting direction reverse	When this terminal is valid, the direction of PID action is opposite to the direction set by F5-03.
36	External stop terminal 1	When the keyboard control is enabled, this terminal can be used to stop the frequency converter, which is equivalent to the function of the STOP button on the keyboard.
37	Control command switching terminal 2	Used for switching between terminal control and communication control. If the command source is selected as the terminal control, the system switches to communication control when the terminal is valid; vice versa.
38	PID integration pause	When the terminal is valid, the integral adjustment function of the PID is suspended, but the PID The proportional adjustment and differential adjustment functions are still valid.
39	Switch between freq. source X and preset freq.	If the terminal is valid, the frequency source X is replaced by the preset frequency (F0-06).



Set value	Function	Description
40	Switch between freq. source Y and preset freq.	If the terminal is valid, the frequency source Y is replaced by the preset frequency (F0-06).
41	Motor's selection terminal 1	Two sets of motor parameters can be switched through the two states of the terminal. See Table 3 for details.
42	Motor's selection terminal 2	
43	PID parameters switching	When the condition of PID parameter switching is DI terminal (F5-18=1) and the terminal is invalid, the PID parameter uses F5-05~F5-07; when the terminal is valid, F5-15~F5-17 is used.
44	User's defined fault 1	When the user-defined faults 1 and 2 are valid, the frequency converter will alarm Err27 and Err28 respectively, and the frequency converter will select the action mode selected by F8-48 according to the fault protection action.
45	User's defined fault 2	
46	Switching between speed control and torque control	The frequency converter is switched between torque control and speed control mode. The frequency converter runs in the mode defined by C6-00 (speed/torque control mode), and when this terminal is valid, it switches to another mode. It can be switched through the terminal during operation and takes effect immediately after switching.
47	Emergency stop	When the terminal is valid, the frequency converter stops at the fastest speed, and the current is at the set current upper limit during the stop. This function is used to meet the requirement that the frequency converter needs to stop as soon as possible when the system is in an emergency.
48	External stop terminal 2	In any control mode (panel control, terminal control, communication control), this terminal can be used to decelerate the frequency converter, and the deceleration time is fixed to the deceleration time 4.
49	Decel DC braking	When this terminal is valid, the frequency converter will decelerate to the stop DC braking start frequency and then switch to the DC braking state.
50	Current running hour clear	When the terminal is valid, the frequency converter's runtime is cleared. This function needs to be used together with the timing run (F2-43) and the current runtime reach (F2-46).
51	Location arrive input signal	The location stop function is effective, and the downtime operation frequency reaches the stopping frequency of the DC brake. The DC braking process begins when the location arrives input signal is effective.

Four multi-stage command terminals can be combined into 16 states, and each of these 16 states corresponds to 16 command set values. The details are shown in Table 1:

**Schedule 1: Description of multi-stage commands**

K4	K3	K2	K1	Command setting	Corresponding parameter
OFF	OFF	OFF	OFF	Multistage command 0	F4-00
OFF	OFF	OFF	ON	Multistage command 1	F4-01
OFF	OFF	ON	OFF	Multistage command 2	F4-02
OFF	OFF	ON	ON	Multistage command 3	F4-03
OFF	ON	OFF	OFF	Multistage command 4	F4-04
OFF	ON	OFF	ON	Multistage command 5	F4-05
OFF	ON	ON	OFF	Multistage command 6	F4-06
OFF	ON	ON	ON	Multistage command 7	F4-07
ON	OFF	OFF	OFF	Multistage command 8	F4-08
ON	OFF	OFF	ON	Multistage command 9	F4-09
ON	OFF	ON	OFF	Multistage command 10	F4-10
ON	OFF	ON	ON	Multistage command 11	F4-11
ON	ON	OFF	OFF	Multistage command 12	F4-12
ON	ON	OFF	ON	Multistage command 13	F4-13
ON	ON	ON	OFF	Multistage command 14	F4-14
ON	ON	ON	ON	Multistage command 15	F4-15

When the frequency source is selected as multi-speed, the function code F4-00~F4-15 100.0% correspond to the maximum frequency F0-07. In addition to the multi-speed function, the multi-stage command can also be used as a given source of PID or as a voltage source for VF separation control to meet the need to switch between different set values.

**Schedule 2 Description of acceleration/deceleration time selection terminal's function**

Terminal 2	Terminal 1	Selection of accel or decel time	Corresponding parameter
OFF	OFF	Acceleration time 1	F0-39、F0-40
OFF	ON	Acceleration time 2	F0-41、F0-42
ON	OFF	Acceleration time 3	F0-43、F0-44
ON	ON	Acceleration time 4	F0-45、F0-46

**Schedule 3 Description of motor selection terminal's function**

Terminal 1	Terminal 2	Motor selection
OFF	OFF	Motor 1
ON	OFF	Motor 2
OFF	ON	Motor 3
ON	ON	Motor 4

Digital input-DI terminal: When any DI terminal function chooses the motor terminal selection 1 or the motor terminal selection 2, C0-01 setting motor selection invalid.

Example: F1-00 chooses 41: the motor terminal selection 1; F1-00 chooses 42: the motor terminal selection 2;

Function code	Item	Setting range	Factory default
F1-10	DI filter time	0.000s ~ 1.000s	0.010s

Set the software filter time for the DI terminal status. If the input terminal is susceptible to interference and causes malfunction, the parameter can be increased to enhance the anti-interference ability. However, this increase in filtering time will cause the response of the DI terminal to be slow.

Function code	Item	Setting range	Factory default
F1-14	DI terminal's effective mode selection 1	0: High level effective 1: Low level effective Ones place: DI1 Tens place: DI2 Hundreds place: DI3 Thousands place: DI4 Ten thousands place: DI5	00000
F1-15	DI terminal's effective mode selection 2	0: High level effective 1: Low level effective Ones place: DI6 Tens place: DI7 Hundreds place: DI8 Thousands place: DI9 Ten thousands place: DI10	00000

Used to set the active status mode of the digital input terminal. When the high level valid is selected, the corresponding DI terminal is valid when connected to COM, and invalid when disconnected. When the low level valid is selected, the corresponding DI terminal is invalid when connected to COM, and invalid when disconnected.

Function code	Item	Setting range	Factory default
F1-16	Terminal command mode	0: Two-line type 1 1: Two-line type 2 2: Three-line type 1 3: Three-line type 2	0

This parameter defines four different ways to control the operation of the frequency converter via external terminals.

Note: For convenience of explanation, the following three terminals DI1, DI2 and DI3 in the multi-function input terminals of DI1~DI10 are selected as external terminals. That is, the function of three terminals DM, DI2, and DI3 is selected by setting the value of F1-00~F1-02. For detailed function definition, see the setting range of F1-00-F1-09.

0: Two-line mode

1: This mode is the most commonly used two-line mode. The forward and reverse running of the motor are determined by the terminals DM and DI2. The function code is set as follows:

Function code	Item	Set value	Description
F1-16	Terminal command mode	0	Two-line type 1
F1-00	DI1 terminal's function selection	1	FWD running
F1-01	DI2 terminal's function selection	2	REV running

As shown in Figure 7-12, in this control mode, K1 is closed and the frequency converter runs forward. K2 is closed and the frequency converter runs reversely. When K1 and K2 are closed or disconnected at the same time, the frequency converter stops running.

1: Two-line mode

2: When this mode is used, the DI1 terminal function as the running enable terminal, and the DI2 terminal function determines the running direction. The function code is set as follows:

7. Details of Parameters

Function code	Item	Set value	Description
F1-16	Terminal command mode	1	Two-line type 2
F1-00	DI1 terminal's function selection	1	Running enable
F1-01	DI2 terminal's function selection	2	FWD and REV running

As shown in Figure 7-13, in this control mode, when the K1 is closed, the frequency converter runs forward when K2 is disconnected, otherwise it runs reversely. When K1 is disconnected, the frequency converter stops running.

2: Three-line control mode.

1: In this mode, DI3 is the enable terminal, and the direction is controlled by DI1 and DI2 respectively. The function code is set as follows:

Function code	Item	Set value	Description
F1-16	Terminal command mode	2	Three-line type 1
F1-00	DI1 terminal's function selection	1	FWD running
F1-01	DI2 terminal's function selection	2	REV running
F1-02	DI3 terminal's function selection	3	Three-line running control

As shown in Figure 7-14, in this control mode, when the SB1 button is closed, press the SB2 button to make the frequency converter run forward. Press the SB3 button to reverse the frequency converter. When the SB1 button is turned off, the frequency converter stops. During normal start-up and operation, it is necessary to keep the SB1 button closed. The commands of the SB2 and SB3 buttons are valid at the end of the closing action. The running status of the frequency converter is based on the last button action of the three buttons.

3: Three-line control mode

2: In this mode, DI3 is the enable terminal and the running command is given by DI1. The direction is determined by the state of DI2. The function code is set as follows:

Function code	Item	Set value	Description
F1-16	Terminal command mode	3	Three-line type 2
F1-00	DI1 terminal's function selection	1	Running enable
F1-01	DI2 terminal's function selection	2	FWD and REV running direction
F1-02	DI3 terminal's function selection	3	Three-line running control

7

K1	K2	Running command
1	0	FWD
0	1	REV
1	1	Stop
0	0	Stop

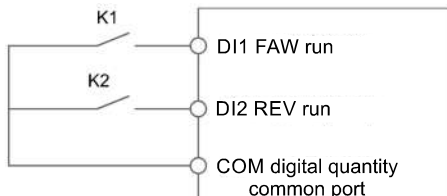


Fig. 7-12 Two-line control mode 1

K1	K2	Running command
1	0	FWD
1	1	REV
0	1	Stop
0	0	Stop

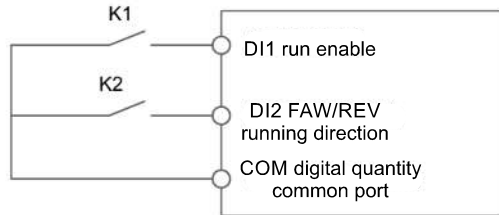


Fig. 7-12 Two-line control mode 1

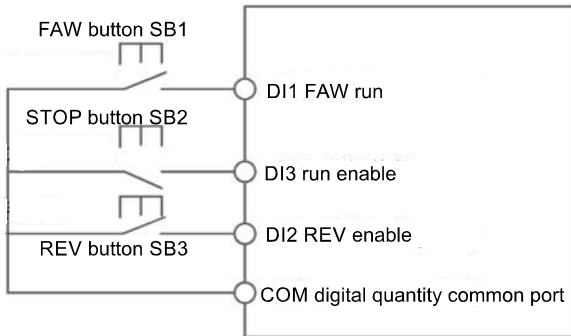


Fig. 7-14 Three-line control mode 1

K1	Running command
0	FWD
1	REV

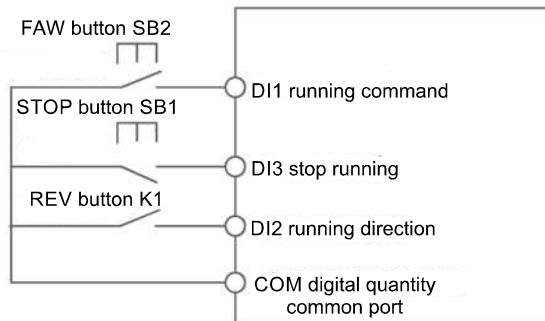


Fig. 7-15 Three-line control mode 2

As shown in Figure 7-15, in this control mode, when the SB1 button is closed, press the SB2 button to make the frequency converter run forward. When K1 is disconnected, the frequency converter runs forward, otherwise, it runs reversely; When the SB1 button is turned off, the frequency converter stops. During normal start-up and operation, it is necessary to keep the SB1 button closed. The commands of the SB2 button are valid at the end of the closing action.

Function code	Item	Setting range	Factory default
F1-17	Terminal UP/DOWN change rate	0.001Hz/s ~ 65.535Hz/s	1.000Hz/s

It is used to set the change rate of frequency, that is, the amount of change in frequency per second.

## 7. Details of Parameters

Function code	Item	Setting range	Factory default
F1-18	PULSE min input	0.00kHz ~ F1-20	0.00kHz
F1-19	Setting corresponding to PULSE min input	-100.0% ~ 100.0%	0.00%
F1-20	PULSE max input	F1-18 ~ 100.00kHz	50.00kHz
F1-21	Setting corresponding to PULSE max input	-100.0% ~ 100.0%	100.00%
F1-22	PULSE filter time	0.00s ~ 10.00s	0.10s

This group of function codes is used to set the relationship between the DI5 pulse frequency and the corresponding settings. The pulse frequency can only be input to the frequency converter via the DI5 channel.

The application of this set of functions is similar to curve 1, please refer to the description of curve 1.

Function code	Item	Setting range	Factory default
F1-23	AI curve selection	Ones place: AI1 curve selection 1: Curve 1 (2 points, see F1-25 ~ F1-28) 2: Curve 2(2 points, see F1-32 ~ F1-35) 3: Curve 3(2 points, see F1-37 ~ F1-40) 4: Curve 4(2 points, see F1-42 ~ F1-49) 5: Curve 5(2 points, see F1-50 ~ F1-57) Tens place: AI2 curve selection, Same as above Hundreds place: AI3 curve selection, Same as above	321

The ones, tens and hundreds digits of the function code are used for selecting set curve corresponding to the analog input AM, AI2 and AI3. Three analog inputs can be selected from any of the five curves. Curve 1, Curve 2, Curve 3, Curve 4 and Curve 5 are set in function code F1-25 ~ F1-57.

The standard unit of XFC550 frequency converter provides 2 analog input ports. For AI3, multi-function input and output expansion cards need to be configured.

7

Function code	Item	Setting range	Factory default
F1-24	Setting selection of AI lower than min input	Ones place: setting selection of AI1 lower than min input 0: Corresponding to min input setting 1: 0.0% Tens place: setting selection of AI2 lower than min input, Same as above Hundreds place: setting selection of AI3 lower than min input, Same as above	000

This function code is used to set how to determine the setting corresponding to the analog quantity when the voltage of the analog input is less than the set "minimum input". The ones, tens, and hundreds digits of the function codes correspond to the analog inputs AI1, AI2, and AI3, respectively.

input corresponding setting" determined by the function code (F1-26, F1-33, F1- 38).

If 1 is selected, then when the AI input is lower than the minimum input, the analog quantity is set to 0.0%.

If 0 is selected, when the AI input is lower than the "minimum input", the corresponding setting of the analog quantity is the curve "minimum

Function code	Item	Setting range	Factory default
F1-25	Min input of AI curve 1	0.00V ~ F1-27	0.00V
F1-26	Setting corresponding to min input of AI curve 1	-100.0% ~ +100.0%	0.0%
F1-27	Max input of AI curve 1	F1-25 ~ +10.00V	10.00V
F1-28	Setting corresponding to max input of AI curve 1	-100.0% ~ +100.0%	100.0%
F1-29	AI1 filter time	0.00s ~ 10.00s	0.10s

The above function codes are used for setting. When the analog input voltage between the analog input voltage and its set value is greater than the set "maximum input" (F1-27), the analog voltage is calculated according to the "maximum input". ;

Similarly, when the analog input voltage is less than the set "minimum input" (F1-25), it is calculated as the minimum input or 0.0% according to the setting of "AI is lower than the minimum input setting selection" (F1-24). .

When the analog input is a current input, 1mA current is equivalent to 0.5V. AI1 input filtering time is used to set the software filtering time of AI1. When the field analog quantity is easily disturbed, please increase the filtering time so that the detected analog quantity tends to be stable, but the larger the filtering time is, the slow response speed of analog quantity detection will be. How to set it needs to be weighed according to the actual application.

In different applications, the meaning of the nominal value corresponding to 100.0% of the analog setting is different. For details, please refer to the description of each application part. The figure below shows two typical settings:

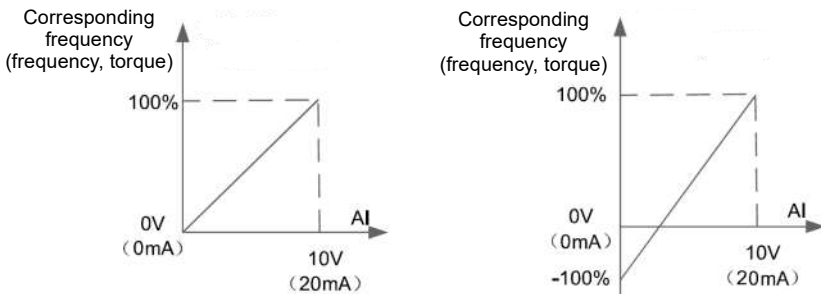


Fig. 7-16 Corresponding relation between analog reference and set value

## 7. Details of Parameters

Function code	Item	Setting range	Factory default
F1-30	Lower limit of AI1 input voltage protection value	0.00V ~ F1-31	3.10V
F1-31	Upper limit of AI1 input voltage protection value	F1-30 ~ 10.00V	6.80V

When the value of analog input AI1 is greater than F1-31, or AI1 input is less than F1-30, the frequency converter's multi-function DO outputs "AI1 input overrun" ON signal to indicate whether the input voltage of AI1 is within the set range.

Function code	Item	Setting range	Factory default
F1-32	Min input of AI curve 2	0.00V ~ F1-34	0.00V
F1-33	Setting corresponding to min input of AI curve 2	-100.0% ~ +100.0%	0.0%
F1-34	Max input of AI curve 2	F1-32 ~ +10.00V	10.00V
F1-35	Setting corresponding to max input of AI curve 2	-100.0% ~ +100.0%	100.0%
F1-36	AI 2 filter time	0.00s ~ 10.00s	0.10s

For function and usage of curve 2, please refer to the description of curve 1.

Function code	Item	Setting range	Factory default
F1-37	Min input of AI curve 3	-10.00V ~ F1-39	-10.00V
F1-38	Setting corresponding to min input of AI curve 3	-100.0% ~ +100.0%	-100.0%
F1-39	Max input of AI curve 3	F1-37 ~ +10.00V	10.00V
F1-40	Setting corresponding to max input of AI curve 3	-100.0% ~ +100.0%	100.0%
F1-41	AI 3 filter time	0.00s ~ 10.00s	0.10s

For function and usage of curve 3, please refer to the description of curve 1.

Function code	Item	Setting range	Factory default
F1-42	Min input of AI curve 4	-10.00V ~ F1-44	0.00V
F1-43	Setting corresponding to min input of AI curve 4	-100.0% ~ +100.0%	0.0%
F1-44	Inflection point 1 input of AI curve 4	F1-42 ~ F1-46	3.00V
F1-45	Setting corresponding to inflection point 1 input of AI curve 4	-100.0% ~ +100.0%	30.0%
F1-46	Inflection point 2 input of AI curve 4	F1-44 ~ F1-48	6.00V
F1-47	Setting corresponding to inflection point 2 input of AI curve 4	-100.0% ~ +100.0%	60.0%
F1-48	Max input of AI curve 4	F1-46 ~ +10.00V	10.00V
F1-49	Setting corresponding to max input of AI curve 4	-100.0% ~ +100.0%	100.0%
F1-50	Min input of AI curve 5	-10.00V ~ F1-52	-10.00V



Function code	Item	Setting range	Factory default
F1-51	Setting corresponding to min input of AI curve 5	-100.0% ~ +100.0%	-100.0%
F1-52	Inflection point 1 input of AI curve 5	F1-50 ~ F1-54	-3.00V
F1-53	Setting corresponding to inflection point 1 input of AI curve 5	-100.0% ~ +100.0%	-30.0%
F1-54	Inflection point 2 input of AI curve 5	F1-52 ~ F1-56	3.00V
F1-55	Setting corresponding to inflection point 2 input of AI curve 5	-100.0% ~ +100.0%	30.0%
F1-56	Max input of AI curve 5	F1-54 ~ +10.00V	10.00V
F1-57	Setting corresponding to max input of AI curve 5	-100.0% ~ +100.0%	100.0%

The functions of curves 4 and 5 are similar to those of curves 1~3, but curves 1~3 are straight lines, while curves 4 and 5 are 4-point curves, which allows for a more flexible correspondence. Figure 7-17 shows a schematic diagram of curves 4-5.

When setting curve 4 and curve 5, it should be noted that the minimum input voltage of the curve, the voltage of the inflection point 1, the voltage of the inflection point 2, and the maximum voltage must be sequentially increased.

F1-23 AI curve selection is used to determine how the analog inputs AI1~AI3 are selected among the five curves.

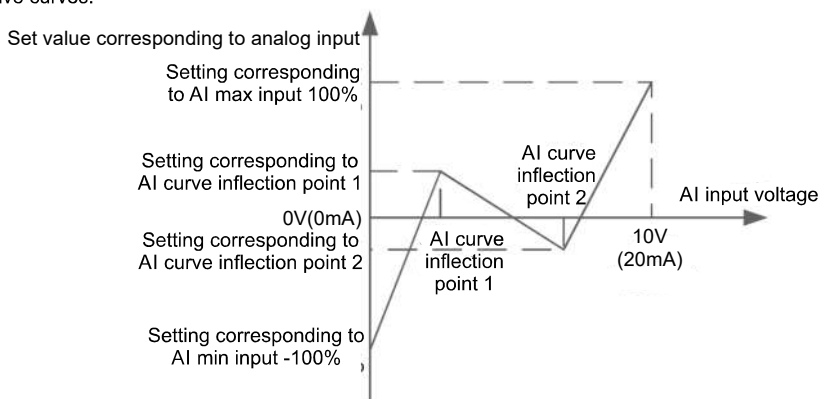


Fig. 7-17 Diagram curves 4 and 5

Function code	Item	Setting range	Factory default
F1-66	AI1 set skip point	-100.0% ~ +100.0%	0.0%
F1-67	AI1 set skip amplitude	0.0% ~ +100.0%	0.5%
F1-68	AI2 set skip point	-100.0% ~ +100.0%	0.0%
F1-69	AI2 set skip amplitude	0.0% ~ +100.0%	0.5%
F1-70	AI3 set skip point	-100.0% ~ +100.0%	0.0%
F1-71	AI3 set skip amplitude	0.0% ~ +100.0%	0.5%

## 7. Details of Parameters

The XFC550's analog inputs AI1~AI3 all have a set point skip function. The skip function is to fix the analog quantity corresponding set value to the value of the skip point when the analog quantity is set to change in the upper and lower sections of the skip point.

For example, the voltage of analog input AI1 fluctuates around 5.00V, the fluctuation range is 4.90V~5.10V, the minimum input of AI1 is 0.00V corresponding to 0.0%, and the maximum input of 10.00V corresponds to 100.%, then the detected AI1 corresponds to the fluctuations between 49.0% and 51.0%. Set AI1 to set the skip point F1-66 to 50.0%, and set AI1 to set the skip width F1-67 to 1.0%. When the AI1 is input, the AI1 input corresponding setting is fixed to 50.0% after the skip function processing. AI1 is transformed into a stable input that eliminates fluctuations.

### 7.3.3 F2: Output terminal parameters

Function code	Item	Setting range	Factory default
F2-00	DO2 terminal output mode selection	0: Pulse output (FMP) 1: On-off output (FMR)	0

The DO2 terminal is a programmable multiplexing terminal that can be used as a high-speed pulse output terminal or as a collector output terminal with open collector. As the pulse output, the maximum frequency of the output pulse is 100 kHz. For related functions, refer to F2-06.

Function code	Item	Setting range	Factory default
F2-01	On-off output function selection	0: No output 1: Frequency converter in operation	0
F2-02	Control board's relay function selection (TA-TB-TC)	2: Fault output (fault stop) 3: Freq. level detection FDT1 output 4: Frequency reach	2
F2-03	Expansion card's relay output function selection (EA-EB-EC)	5: Running at zero speed (no output at stop) 6: Motor overload alarm 7: frequency converter overload alarm	0
F2-04	DO1 output function selection	8: Set count value reach 9: Designated count value reach 10: Length reach 11: PLC circulation complete 12: Total runtime reach 13: Frequency in limitation 14: Torque in limitation 15: Ready for run 16: AI1>AI2 17: Upper limit freq. reach 18: Lower limit freq. reach 19: Undervoltage state output 20: Comm. Setting 23: Running 2 at zero speed (output at stop) 24: Total power-on time reach 25: Freq. level detection FDT2 output	1

Function code	Item	Setting range	Factory default
F2-05	Expansion card DO3 output selection	26: Freq. 1 reach output 27: Freq. 2 reach output 28: Current 1 reach output 29: Current 2 reach output 30: Timing reach output 31: AI1 input overrun 32: Load dropping 33: REV running 34: Zero current state 35: Module temperature reach 36: Output current overrun 37: Lower limit freq. reach (Continue output after stopping) 38: Alarm output (Continue running) 39: Motor over temp warning 40: Current runtime reach 41: Fault output	4

The above five function codes are used to select the functions of five digital outputs, among which TA-TB-TC and EA-EB-EC are relays on the control board and expansion card respectively. The function of the multi-function output terminal is as follows:

Set value	Function	Description
0	No output	The output terminal has no any function.
1	Frequency converter in operation	It indicates that the frequency converter is running and has an output frequency (can be zero). At this time, the ON signal is output.
2	Fault output (fault stop)	When the frequency converter fails and stops, the ON signal is output.
3	Freq. level detection FDT1 output	Please refer to the description of function codes F2-23 and F2-26.
4	Frequency reach	Please refer to the description of function codes F2-25.
5	Running at zero speed (no output at stop)	When the frequency converter runs and the output frequency is 0, the ON signal is output. This signal is OFF when the frequency converter is in the stop state.
6	Motor overload alarm	Before the motor overload protection enables, it is judged according to the threshold value of the overload pre-alarm. The ON signal is output after the pre-alarm threshold is exceeded. For motor overload parameter settings, see function codes F8-02, F8-03, C0-15.
7	Overload warning of freq. converter	The ON signal is output 10s before the frequency converter overload protection enables.
8	Set count value reach	When the count value reaches the value set by A0-08, the ON signal is output.
9	Designated count value reach	When the count value reaches the value set by A0-09, the ON signal is output. For the counting function, pls refers to the function description of group A0.

## 7. Details of Parameters

Set value	Function	Description
10	Length reach	When the actual length detected exceeds the length set by A0-05, the ON signal is output.
11	PLC circulation complete	When the simple PLC runs one cycle, it outputs a pulse signal with a width of 250ms.
12	Total runtime reach	When the total runtime of the frequency converter exceeds the time set by F2-42, the ON signal is output.
13	Frequency in limitation	When the set frequency exceeds the upper limit frequency or the lower limit frequency, and the frequency converter's output frequency also reaches the upper limit frequency or lower limit frequency, the ON signal is output.
14	Torque in limitation	When the output torque reaches the torque limit value in the speed control mode, the frequency converter is in the stall protection state and outputs the ON signal.
15	Ready for run	When the power supply of the frequency converter's main circuit and control loop has been stabilized, and no fault information is detected, the frequency converter outputs ON signal when it is in the running state.
16	AI1>AI2	When the value of the analog input AI1 is greater than the input value of AI2, the ON signal is output.
17	Upper limit freq. reach	When the running frequency reaches the upper limit frequency, the ON signal is output.
18	Lower limit freq. reach	When the running frequency reaches the lower limit frequency, the ON signal is output. This signal is OFF in the stop state.
19	Undervoltage state output	When the frequency converter is in the state of under voltage, it outputs ON signal.
20	Comm. setting	Pls refer to communication protocol
23	Running 2 at zero speed (output at stop)	When the frequency verter output frequency is 0, the ON signal is output. This signal is also ON in the stop state.
24	Total power-on time reach	When the total power-on time (b0-06) of the frequency converter exceeds the time set by F2-41, the ON signal is output.
25	Freq. level detection FDT2 output	Please refer to the description of function codes F2-24and F2-27
26	Freq. 1 reach output	Please refer to the description of function codes F2-28 and F2-29
27	Freq. 2 reach output	Please refer to the description of function codes F2-30 and F2-31
28	Current 1 reach output	Please refer to the description of function codes F2-36 and F2-37
29	Current 2 reach output	Please refer to the description of function codes F2-38 and F2-39
30	Timing reach output	When the timing function selection (F2-43) is valid, the frequency converter will output the ON signal after the current running time reaches the set timing time.
31	AI1 input overrun	When the value of AI1 is greater than F1-31 (AI1 input protection upper limit) or less than F1-30 (AI1 input protection lower limit), the ON signal is output.

Set value	Function	Description
32	Load dropping	When the frequency converter is in the off state, it outputs the ON signal.
33	REV running	When the frequency converter is in reverse running state, it output the ON signal.
34	Zero current state	Please refer to the description of function codes F2-32 and F2-33.
35	Module temperature reach	When the inverter module's heatsink temperature (F8-69) reaches the set module temperature reach value (F2-40), the ON signal is output.
36	Output current overrun	Please refer to the description of function codes F2-34 and F2-35.
37	Lower limit freq. reach	When the running frequency reaches the lower limit frequency, the ON signal is output. This signal is also ON during the stop state.
38	Alarm output (Continue running)	When the frequency converter fails and the processing mode of the fault is continuous run, the frequency converter outputs alarm.
39	Motor over temp warning	When the motor's temperature reaches F8-56 (motor overheat pre-alarm threshold), the ON signal is output. (Motor temperature can be viewed through d0-34).
40	Current runtime reach	When the frequency converter starts running for longer than the time set by F2-46, it outputs ON signal.

Function code	Item	Setting range	Factory default
F2-06	Pulse output function selection	0: Operating frequency 1: Set frequency	0
F2-07	AO1 output function selection	2: Output current 3: Output torque	0
F2-08	Expansion card AO2 output function selection	4: Output power 5: Output voltage 6: Pulse input (100% corresponds to 100kHz) 7: AI1 8: AI2 9: AI3(expansion card) 10: Length 11: Count value 12: Communication setting 13: Motor speed 14: Output current (100% corresponds to 100A) 15: Bus voltage (100% corresponds to 100V) 16: Motor output torque (actual value, Percent relative to the motor)	1

The pulse output terminal's output frequency range is 0.01kHz ~ F2-09 (pulse output maximum frequency), and F2-09 can be set between 0.01kHz ~ 100.00kHz. The output range of analog output A01 and AO2 is 0V ~ 10V, or 0mA ~ 20mA, the range of pulse output or analog output, and the calibration relationship with the corresponding function is shown in the following table:

## 7. Details of Parameters

Set value	Function	Description
0	Running frequency	0 ~ max output frequency
1	Set frequency	0 ~ max output frequency
2	Output current	0 ~ 2 times of motor's rated current
3	Output torque (absolute value, percentage relative to motor)	0 ~ 2 times of motor's rated torque
4	Output power	0 ~ 2 times of motor's rated power
5	Output voltage	0 ~ 1.2 times of motor's rated voltage
6	Pulse input	0.01kHz ~ 100.00kHz
7	AI1	0V ~ 10V (or 0~20mA)
8	AI2	0V ~ 10V (or 0~20mA)
9	AI3	0V~10V (or 0~20mA)
10	Length	0 ~ max set length
11	Count value	0 ~ max count value
12	Communication setting	0 ~ 100.0%
13	Motor speed	0 ~ Speed corresponding to max output freq.
14	Output current	0.0A ~ 1000.0A
15	Output voltage	0.0V ~ 1000.0V
16	Motor output torque (actual value, percentage relative to motor)	-2 times of motor's rated torque ~ 2 times of motor's rated torque

Function code	Item	Setting range	Factory default
F2-09	Pulse output max freq.	0.01kHz ~ 100.00kHz	50.00kHz

When the DO2 terminal is selected as the pulse output, this function code is used to select the maximum frequency value of the output pulse.

Function code	Item	Setting range	Factory default
F2-10	AO1 bias coefficient	-100.0% ~ +100.0%	0.0%
F2-11	AO1 gain	-10.00 ~ +10.00	1.00
F2-12	Expansion card AO2 bias coefficient	-100.0% ~ +100.0%	0.0%
F2-13	Expansion card AO2 gain	-10.00 ~ +10.00	1.00

The above function codes are generally used to correct the zero drift of the analog output and the deviation of the output amplitude. It can also be used to customize the required AO output curve. If the zero offset is represented by "b", the gain is represented by k, the actual output is represented by Y, and the standard output is represented by X. The actual output is:  $Y=kX+b$ , where the zero offset coefficient of AO1 and AO2 corresponds to 10V. (or 20mA), the standard output refers to the output of 0V ~ 10V (or 0mA ~ 20mA) corresponding to the analog output without zero offset and gain correction.

For example, if the analog output is the running frequency, if you want the actual output to be 8V (or 16mA) when the frequency is 0, as shown in the figure below, you need to set the zero offset to "80%"; if you want the actual frequency to be the maximum frequency, output 3V (or 6mA), as shown in the figure below, you need to set the gain to "-0.50".

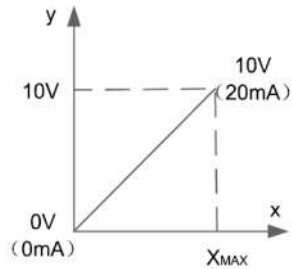


Fig. 7-18 Output diagram without zero offset or gain

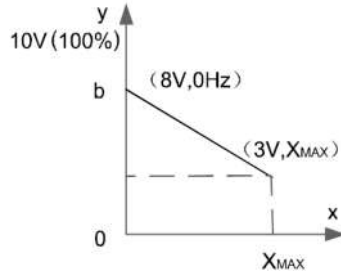


Fig. 7-19 Output diagram without zero offset or gain (Voltage type)

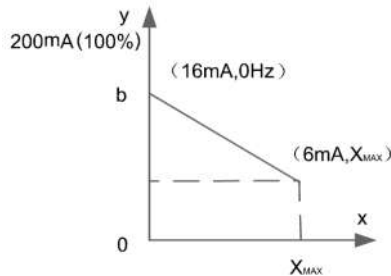


Fig. 7-20 Output diagram without zero offset or gain (Voltage type)

Function code	Item	Setting range	Factory default
F2-17	On-off output delay time	0.0s ~ 3600.0s	0.0s
F2-18	RELAY1 output delay time	0.0s ~ 3600.0s	0.0s
F2-19	RELAY 2 output delay time	0.0s ~ 3600.0s	0.0s
F2-20	DO1 output delay time	0.0s ~ 3600.0s	0.0s
F2-21	DO3 output delay time	0.0s ~ 3600.0s	0.0s

It is used to set the output terminal's on-off value, relay 1, relay 2, DO1 and DO3, the delay time from the change of state to the actual output change.

7. Details of Parameters

Function code	Item	Setting range	Factory default
F2-22	DO output terminal's effective state selection	0: Positive logic 1: Negative logic Ones place: on-off Tens place: RELAY 1 Hundreds place: RELAY 2 Thousands place: DO1 Ten thousands place: DO3	00000

Define the output logic of the output terminal's on-off value, relay 1, relay 2, DO1 and DO3.

0: Positive logic, the digital output terminal and the corresponding common terminal are connected to the active state, and the disconnection is the invalid state;

1: Negative logic, the digital output terminal and the corresponding common terminal are connected to the invalid state, and the disconnection is the active state.

Function code	Item	Setting range	Factory default
F2-23	Freq. detection value (FDT1)	0.00Hz ~ max frequency	50.00Hz
F2-26	Freq. detection lagged value(FDT1)	0.0% ~ 100.0% (FDT1 level)	5.0%

When the running frequency is higher than the frequency detection value, the multi-function DO of the frequency converter outputs ON signal, and after the frequency is lower than the detection value, the ON signal output by DO is canceled. The above parameters are used to set the detection value of the output frequency and the hysteresis value of the output action release. Where F2-26 is the percentage of the hysteresis frequency relative to the frequency detection value F2-23. The figure below shows the function of the FDT function.

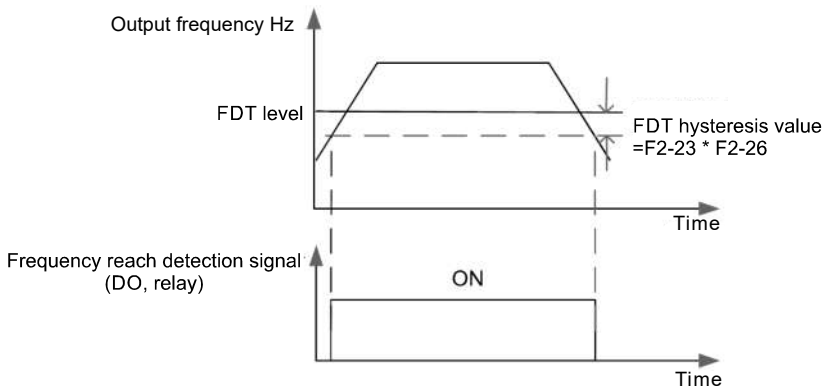


Fig. 7-21 Diagram of FDT level

Function code	Item	Setting range	Factory default
F2-24	Freq. detection value (FDT2)	0.00Hz ~ max frequency	50.00Hz
F2-27	Freq. detection lagged value (FDT2)	0.0% ~ 100.0% (FDT2 level)	5.0%



When the running frequency is higher than the frequency detection value, the multi-function DO of the frequency converter outputs ON signal, and after the frequency is lower than the detection value, the ON signal output by DO is canceled. The above parameters are used to set the detection value of the output frequency and the hysteresis value of the output action release. Where F2-27 is the percentage of the hysteresis frequency relative to the frequency detection value F2-24.

Function code	Item	Setting range	Factory default
F2-25	Freq. detection width	0.0% ~ 100.0%(max frequency)	0.0%

When the running frequency of the frequency converter is within a certain range of the target frequency, the frequency converter multi-function DO outputs ON signal. This parameter is used to set the detection range of the frequency arrival, which is a percentage relative to the maximum frequency. The figure below shows the frequency reach.

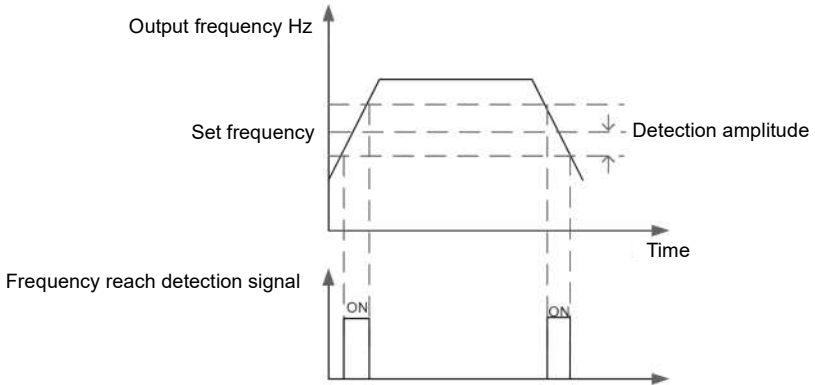


Fig. 7-22 Diagram of frequency reach detection amplitude

Function code	Item	Setting range	Factory default
F2-28	Random reach freq. detection value 1	0.00Hz ~ max frequency	50.00Hz
F2-29	Random reach freq. detection width 1	0.00Hz ~ 100% (max frequency)	0.0%
F2-30	Random reach freq. detection value 2	0.00Hz ~ max frequency	50.00Hz
F2-31	Random reach freq. detection width 2	0.00Hz ~ 100% (max frequency)	0.0%

When the output frequency of the frequency converter is within the positive and negative detection range of any reach frequency detection value, the multi-function DO outputs an ON signal. The XFC550 provides two sets of random reach frequency detection parameters, and the frequency value and the frequency detection range are respectively set. Figure 7-23 shows a schematic of this function.

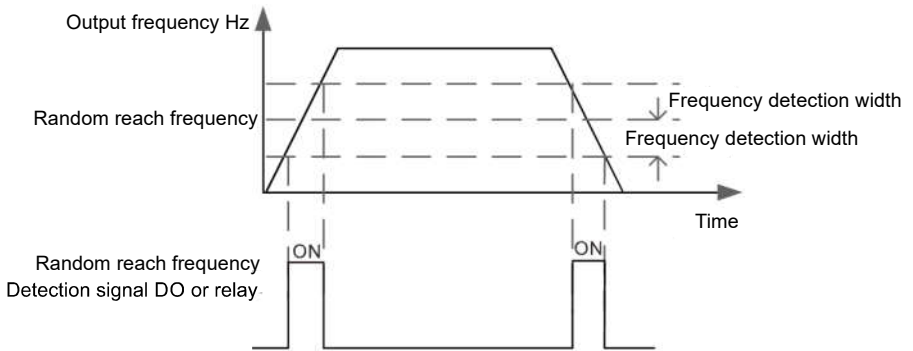


Fig. 7-23 Diagram random reach frequency

Function code	Item	Setting range	Factory default
F2-32	Zero current detection level	0.0% ~ 300.0% 100% corresponding to motor's rated current	5.0%
F2-33	Zero current detection delay time	0.01s ~ 600.00s	0.10s

When the output current of the frequency converter is less than or equal to the zero current detection level and the duration exceeds the zero current detection delay time, the frequency converter's multi-function DO outputs ON signal. Figure 7-24 shows the diagram of zero current detection

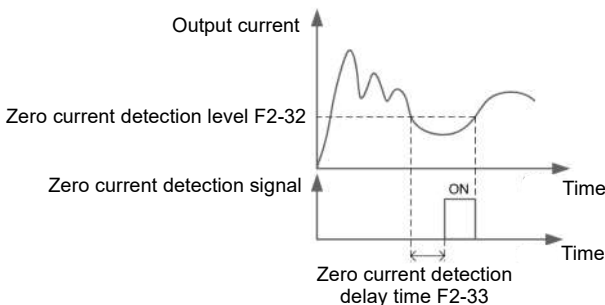


Fig. 7-24 Diagram of zero current detection

Function code	Item	Setting range	Factory default
F2-34	Output current overrun	0(No detection) 0.1%~300.0% (motor's rated current)	200.0%
F2-35	Output current overrun detection delay time	0.00s ~ 600.00s	0.00s

When the output current of the frequency converter is greater than or exceeds the detection point and the duration exceeds the software over-current detection delay time, the frequency converter's three multi-function DO outputs ON signal, and Figure 7-25 shows the output current over-limit function.

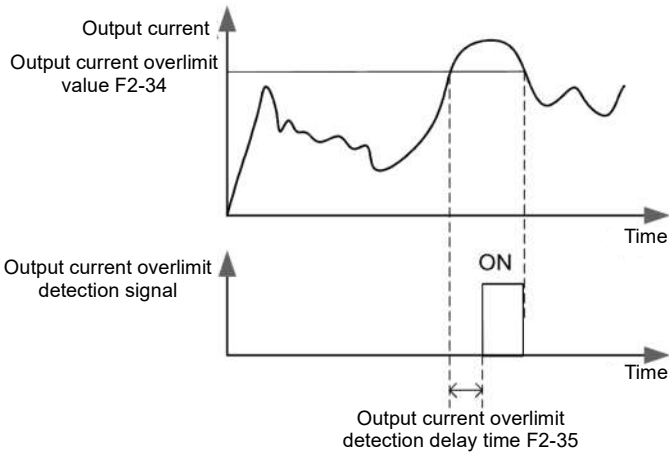


Fig. 7-25 Diagram of output current overlimit detection

Function code	Item	Setting range	Factory default
F2-36	Random reach current 1	0.0% ~ 300.0% (motor's rated current)	100.0%
F2-37	Width of random reach current 1	0.0% ~ 300.0% (motor's rated current)	0.0%
F2-38	Random reach current 2	0.0% ~ 300.0% (motor's rated current)	100.0%
F2-39	Width of random reach current 1	0.0% ~ 300.0% (motor's rated current)	0.0%

When the output current of the frequency converter is within the positive and negative detection width of any set current, the frequency converter's multi-function DO outputs ON signal. The XFC550 provides two sets of random current and detection width parameters. The figure below shows the function diagram.

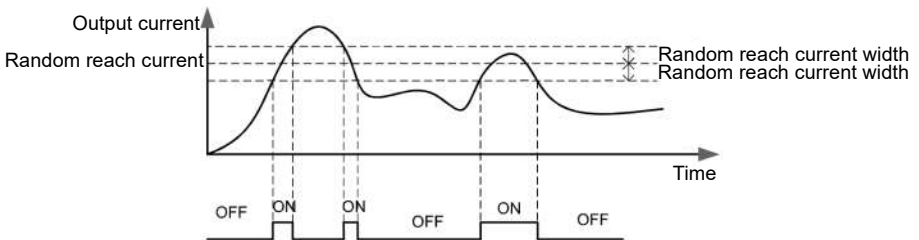


Fig. 7-26 Diagram of random reach frequency

Function code	Item	Setting range	Factory default
F2-40	Module temp reach	0°C ~ 100°C	75°C

When the temperature of the frequency converter's radiator reaches this temperature, the frequency converter's multi-function DO outputs the "module temperature reached" ON signal.

Function code	Item	Setting range	Factory default
F2-41	Set total power-on reach time	0h ~ 65000h	0h

## 7. Details of Parameters

When the total power-on time (b0-06) reaches the power-on time set by F2-41, the frequency converter's multi-function digital DO outputs an ON signal. The following is an example of its application: combined with the virtual DI\DO function, the frequency converter's fault alarm output is realized after the set power-on time reaches 100 hours.

- Solution: virtual DI1 terminal function, set to user-defined fault 1: A2-00=44;
- Virtual DI1 terminal's valid state, set to source from virtual DO1: A2-05=0000;
- Virtual DO1 function, set to power-on time reach: A2-11=24;
- Set the total power-on reach time of 100 hours: F2-41=100

Then, when the total power-on time reaches 100 hours, the frequency converter outputs fault Err27.

Function code	Item	Setting range	Factory default
F2-42	Set total run reach time	0h ~ 65000h	0h

It is used to set the run time of the frequency converter. When the total run time (b0-08) reaches this set value, the frequency converter's multi-function digital DO outputs ON signal.

Function code	Item	Setting range	Factory default
F2-43	Timing function selection	0: Effective 1: Ineffective	0
F2-44	Timing run time selection	0: F2-45 setting 1: A11 2: A12 3: A13 Analog input range corresponds to F2-45	0
F2-45	Timing run time	0.0min ~ 6500.0min	0.0min

This group of parameters is used to complete the timing operation of the frequency converter. When the timing function selection of F2-43 is valid, the frequency converter will start timing when it starts. When the set timing operation time is reached, the frequency converter will automatically stop and the multi-function DO will output an ON signal. Each time the frequency converter starts, it starts from 0, and the remaining run time can be viewed through d0-20. The timing run time is set by F2-44 and F2-45, and the time unit is minute.

Function code	Item	Setting range	Factory default
F2-46	Current run reach time setting	0.0min ~ 6500.0min	0.0min

When the run time of this startup reaches this time, the frequency conerter's multi-function digital DO outputs an ON signal of "current runtime reached".

### 7.3.4: F3:AIAO calibration

Function code	Item	Setting range	Factory default
F3-00	A11 measured voltage 1	0.500V ~ 4.000V	factory calibration
F3-01	A11 displayed voltage 1	0.500V ~ 4.000V	factory calibration
F3-02	A11 measured voltage 2	6.000V ~ 9.999V	factory calibration

Function code	Item	Setting range	Factory default
F3-03	AI1 displayed voltage 2	6.000V ~ 9.999V	factory calibration
F3-04	AI2 measured voltage 1	0.500V ~ 4.000V	factory calibration
F3-05	AI2 displayed voltage 1	0.500V ~ 4.000V	factory calibration
F3-06	AI2 measured voltage 2	6.000V ~ 9.999V	factory calibration
F3-07	AI2 displayed voltage 2	6.000V ~ 9.999V	factory calibration
F3-08	AI3 measured voltage 1	-9.999V ~ 10.000V	factory calibration
F3-09	AI3 displayed voltage 1	-9.999V ~ 10.000V	factory calibration
F3-10	AI3 measured voltage 2	-9.999V ~ 10.000V	factory calibration
F3-11	AI3 displayed voltage 2	-9.999V ~ 10.000V	factory calibration

This group of function codes is used to correct the analog input AI to eliminate the effects of zero offset and gain on the AI input. The function parameters of this group have been corrected at the factory, and will be restored to the factory-corrected value when the factory value is restored. Generally no correction is required at the application site. The measured voltage refers to the actual voltage measured by a measuring instrument such as a multimeter. The display voltage refers to the voltage display value sampled by the frequency converter. See the d0 group AI correction voltage (d0-21, d0-22, d0-23).

During calibration, two voltage values are input to each AI input port, and the value measured by the multimeter and the value read by the group d0 are accurately input into the above function code, and the frequency converter automatically performs the zero offset of the AI and correction of the gain. For the case where the user's given voltage does not match the actual sampling voltage of the frequency converter, the field corrective method can be used to make the sampling value of the frequency converter consistent with the expected set value. Taking AI1 as an example, the field corrective method is as follows:

Given the AI1 voltage signal (around 2V) and the measured AI1 voltage value are input in function parameter F3-00 and check the display value of d0-21, and save it in function parameter F3-01. Given the AI1 voltage signal (about 8V) and the measured AI1 voltage value are input in function parameter F3-02 and check the display value of d0-21, and save it in function parameter F3-03. When AI2 and AI3 are corrected, the actual sampling voltage viewing positions are d0-22 and d0-23, respectively. For AI2 and AI3, it is recommended to use 2V and 8V as the correction points. For AI1, it is recommended to sample -8V and 8V as the correction point.

Function code	Item	Setting range	Factory default
F3-12	AO1 target voltage 1	0.500V ~ 4.000V	factory calibration
F3-13	AO1 measured voltage 1	0.500V ~ 4.000V	factory calibration

## 7. Details of Parameters

Function code	Item	Setting range	Factory default
F3-14	AO1 target voltage 2	6.000V ~ 9.999V	factory calibration
F3-15	AO1 measured voltage 2	6.000V ~ 9.999V	factory calibration
F3-16	AO2 target voltage 1	0.500V ~ 4.000V	factory calibration
F3-17	AO2measured voltage 1	0.500V ~ 4.000V	factory calibration
F3-18	AO2 target voltage 2	6.000V ~ 9.999V	factory calibration
F3-19	AO2 measured voltage 2	6.000V ~ 9.999V	factory calibration

This group of function codes is used to correct the analog output AO. The function parameters of this group have been corrected at the factory, and will be restored to the factory-corrected value when the factory value is restored. Generally no correction is required at the application site. The target voltage is the theoretical output voltage value of the frequency converter. The measured voltage refers to the actual output voltage measured by an instrument such as a multimeter.

### 7.3.5 F4: Multistage and simple PLC parameters

Function code	Item	Setting range	Factory default
F4-00	Multistage command 0	-100.0% ~ 100.0%	0.0%
F4-01	Multistage command 1	-100.0% ~ 100.0%	0.0%
F4-02	Multistage command 2	-100.0% ~ 100.0%	0.0%
F4-03	Multistage command 3	-100.0% ~ 100.0%	0.0%
F4-04	Multistage command 4	-100.0% ~ 100.0%	0.0%
F4-05	Multistage command 5	-100.0% ~ 100.0%	0.0%
F4-06	Multistage command 6	-100.0% ~ 100.0%	0.0%
F4-07	Multistage command 7	-100.0% ~ 100.0%	0.0%
F4-08	Multistage command 8	-100.0% ~ 100.0%	0.0%
F4-09	Multistage command 9	-100.0% ~ 100.0%	0.0%
F4-10	Multistage command 10	-100.0% ~ 100.0%	0.0%
F4-11	Multistage command 11	-100.0% ~ 100.0%	0.0%
F4-12	Multistage command 12	-100.0% ~ 100.0%	0.0%
F4-13	Multistage command 13	-100.0% ~ 100.0%	0.0%
F4-14	Multistage command 14	-100.0% ~ 100.0%	0.0%
F4-15	Multistage command 15	-100.0% ~ 100.0%	0.0%

Multi-stage command can be used in three situations: as a frequency source, as a VF-separation voltage source, as a set source for the PID process. The dimensions of the multi-stage commands are relative values, ranging from -100.0% to 100.0%. When it is used as a frequency source, it is a percentage of the relative maximum frequency; when used as a VF separation voltage source, it is a percentage relative to the rated voltage of the motor; and since the PID reference is originally a relative value, the multi-stage command as a PID setting source does not require dimensional transformation.

The multi-stage command needs to be switched according to the different states of the multi-function digital DI. For details, please refer to the related description of the group F1.

Function code	Item	Setting range	Factory default
F4-16	Simple PLC running mode	0: Stop after single running 1: Retain final value after single running 2: Continue circulating	0

The simple PLC function has two functions: as a frequency source or as a voltage source for VF separation.

Figure 7-27 is a diagram of a simple PLC as a frequency source. When the simple PLC is used as the frequency source, the positive and negative of F4-00~F4-15 determine the running direction. If it is negative, it means the frequency converter runs in the opposite direction.

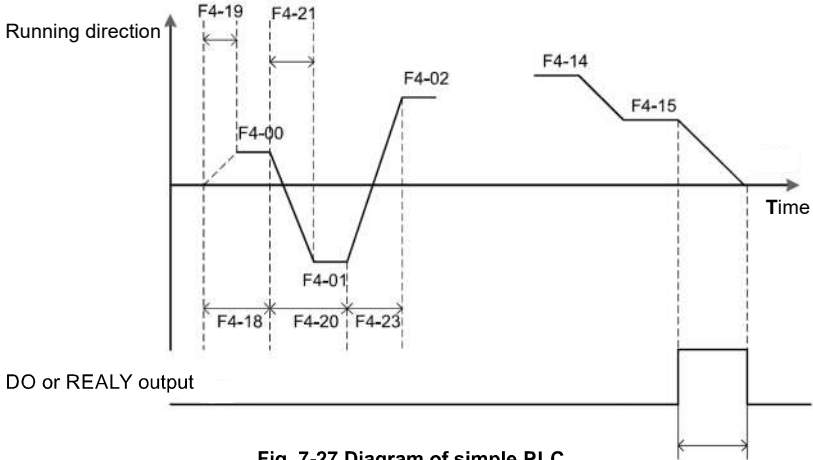


Fig. 7-27 Diagram of simple PLC

Function code	Item	Setting range	Factory default
F4-17	Simple PLC power-off memory selection	Ones place: Power-off memory selection 0: No memory after power-off 1: Memory after power-off Tens place: Stop memory selection 0: No memory after stopping 1: Memory after stopping	00

PLC power-off memory refers to the running phase and running frequency of the PLC before the power-off, and continues to run from the memory phase the next time the power is turned on. If you choose not to memorize, the PLC process will be restarted every time you power up.

The PLC stop memory records the previous PLC running phase and running frequency when it stops, and continues to run from the memory phase in the next run. If you choose not to memorize, the PLC process will be restarted each time you start.

Function code	Item	Setting range	Factory default
F4-18	Simple PLC runtime at stage 0	0.0s (h) ~ 6553.5s (h)	0.0s (h)
F4-19	Simple PLC accel/decel time selection at stage 0	0 ~ 3	0

7. Details of Parameters

Function code	Item	Setting range	Factory default
F4-20	Simple PLC runtime at stage 1	0.0s (h) ~ 6553.5s (h)	0.0s (h)
F4-21	Simple PLC accel/decel time selection at stage 1	0 ~ 3	0
F4-22	Simple PLC runtime at stage 2	0.0s (h) ~ 6553.5s (h)	0.0s (h)
F4-23	Simple PLC accel/decel time selection at stage 2	0 ~ 3	0
F4-24	Simple PLC runtime at stage 3	0.0s (h) ~ 6553.5s (h)	0.0s (h)
F4-25	Simple PLC accel/decel time selection at stage 3	0 ~ 3	0
F4-26	Simple PLC runtime at stage 4	0.0s (h) ~ 6553.5s (h)	0.0s (h)
F4-27	Simple PLC accel/decel time selection at stage 4	0 ~ 3	0
F4-28	Simple PLC runtime at stage 5	0.0s (h) ~ 6553.5s (h)	0.0s (h)
F4-29	Simple PLC accel/decel time selection at stage 5	0 ~ 3	0
F4-30	Simple PLC runtime at stage 6	0.0s (h) ~ 6553.5s (h)	0.0s (h)
F4-31	Simple PLC accel/decel time selection at stage 6	0 ~ 3	0
F4-32	Simple PLC runtime at stage 7	0.0s (h) ~ 6553.5s (h)	0.0s (h)
F4-33	Simple PLC accel/decel time selection at stage 7	0 ~ 3	0
F4-34	Simple PLC runtime at stage 8	0.0s (h) ~ 6553.5s (h)	0.0s (h)
F4-35	Simple PLC accel/decel time selection at stage 8	0 ~ 3	0
F4-36	Simple PLC runtime at stage 9	0.0s (h) ~ 6553.5s (h)	0.0s (h)
F4-37	Simple PLC accel/decel time selection at stage 9	0 ~ 3	0
F4-38	Simple PLC runtime at stage 10	0.0s (h) ~ 6553.5s (h)	0.0s (h)
F4-39	Simple PLC accel/decel time selection at stage 10	0 ~ 3	0
F4-40	Simple PLC runtime at stage 11	0.0s (h) ~ 6553.5s (h)	0.0s (h)
F4-41	Simple PLC accel/decel time selection at stage 11	0 ~ 3	0



Function code	Item	Setting range	Factory default
F4-42	Simple PLC runtime at stage 12	0.0s (h) ~ 6553.5s (h)	0.0s (h)
F4-43	Simple PLC accel/decel time selection at stage 12	0 ~ 3	0
F4-44	Simple PLC runtime at stage 13	0.0s (h) ~ 6553.5s (h)	0.0s (h)
F4-45	Simple PLC accel/decel time selection at stage 13	0 ~ 3	0
F4-46	Simple PLC runtime at stage 14	0.0s (h) ~ 6553.5s (h)	0.0s (h)
F4-47	Simple PLC accel/decel time selection at stage 14	0 ~ 3	0
F4-48	Simple PLC runtime at stage 15	0.0s (h) ~ 6553.5s (h)	0.0s (h)
F4-49	Simple PLC accel/decel time selection at stage 15	0 ~ 3	0
F4-50	Simple PLC runtime unit	0: s (s) 1: h (h)	0
F4-51	Multistage command 0 reference	0: Function code F4-00 reference 1: AI1 2: AI2 3: AI3 4: PULSE 5: PID 6: Preset frequency (F0-06) reference UP/DOWN modifiable	0

This parameter determines the given channel of the multi-stage command 0. In addition to F4-00, multi-stage command 0 has a variety of other options to facilitate switching between multi-stage commands and other given modes. When a multi-stage command is used as a frequency source or a simple PLC as a frequency source, switching between the two frequency sources can be easily realized.

### 7.3.6 F5: PID control parameters

Function code	Item	Setting range	Factory default
F5-00	PID reference source	0: F5-01 reference 1: AI1 2: AI2 3: AI3 4: Pulse setting (DI5) 5: Communication reference 6: Multistage command reference	0
F5-01	PID value reference	0.0% ~ 100.0%	50.0%

This parameter is used to select the target channel for the process PID. The set target amount of the process PID is a relative value, and the setting range is 0.0% to 100.0%. The feedback amount of the same PID is also the relative amount, and the role of the PID is to make the two relative quantities the same.

## 7. Details of Parameters

Function code	Item	Setting range	Factory default
F5-02	PID feedback source	0: AI1 1: AI2 2: AI3 3: AI1-AI2 4: Pulse setting (DI5) 5: Communication give 6: AI1+AI2 7: MAX ( AI1 ,  AI2 ) 8: MIN ( AI1 ,  AI2 )	0

This parameter is used to select the feedback signal channel of the process PID. The feedback amount of the process PID is also a relative value, and the setting range is 0.0% to 100.0%.

Function code	Item	Setting range	Factory default
F5-03	PID action direction	0: Positive action 1: Negative action	0

Positive action: When the PID feedback signal is less than the reference, the frequency converter's output frequency rises, such as winding tension control occasions. Reaction: When the feedback signal of the PID is less than the reference, the frequency converter's output frequency decreases, such as unwinding tension control occasions. This function is affected by the reverse direction of the multi-function terminal PID (function 35), so you need to pay attention to it during use.

Function code	Item	Setting range	Factory default
F5-04	PID reference feedback range	0 ~ 65535	1000

The PID reference feedback range is a dimensionless unit for the PID reference display d0-15 and the PID feedback display d0-16.

The relative value of the reference feedback of the PID is 100.0%, corresponding to the reference feedback range F5-04.

For example, if F5-04 is set to 2000, when the PID reference is 100.0%, the PID reference display d0-15 is 2000.

Function code	Item	Setting range	Factory default
F5-05	Proportional gain Kp1	0.0 ~ 100.0	20.0
F5-06	Integral time T11	0.01s ~ 10.00s	2.00s
F5-07	Derivative time Td1	0.000s ~ 10.000s	0.000s

Proportional gain Kp1: Determines the adjustment strength of the entire PID regulator. The larger the Kp1, the greater the adjustment strength. The parameter 100.0 indicates that when the deviation between the PID feedback amount and the reference amount is 100.0%, the amplitude of the adjustment of the output frequency command by the PID regulator is the maximum frequency.

Integration time T11: Determines the strength of the PID regulator integral adjustment. The shorter the integration time, the greater the adjustment intensity.

The integration time means that when the deviation between the PID feedback amount and the reference amount is 100.0%, the integral regulator continuously adjusts through the time, and the adjustment amount reaches the maximum frequency.

Derivative time Td1: Determines the strength of the PID regulator's adjustment to the rate of change of the deviation. The longer the differentiation time, the greater the adjustment intensity.

The derivative time means that when the feedback amount changes by 100.0% during this time, the adjustment amount of the differential regulator is the maximum frequency.

Function code	Item	Setting range	Factory default
F5-08	PID reverse cutoff freq.	0.00 ~ max frequency	2.00Hz

In some cases, only when the PID output frequency is negative (ie, the frequency converter is reversed), it is possible for the PID to control the reference amount and the feedback amount to the same state, but the excessive reverse frequency is not allowed for some occasions. F5-08 is used to determine the upper limit of the reverse frequency. When the frequency source is primary + secondary (PID), the upper limit of the PID reverse cutoff frequency is not limited, that is, F5-08 is invalid.

Function code	Item	Setting range	Factory default
F5-09	PID deviation limit	0.0% ~ 100.0%	0.0%

When the deviation between the PID reference amount and the feedback amount is less than F5-09, the PID stops the adjustment. In this way, the output frequency is stable when the deviation from the feedback is small, which is effective for some closed-loop control applications.

Function code	Item	Setting range	Factory default
F5-10	PID derivative amplitude limiting	0.00% ~ 100.00%	0.10%

In the PID regulator, the function of the differential is relatively sensitive, and it is easy to cause the system to oscillate. For this reason, the PID is generally differentiated into a small range, and F5-10 is used to set the range of the PID differential output.

Function code	Item	Setting range	Factory default
F5-11	PID reference change time	0.00 ~ 650.00s	0.00s

The PID reference change time refers to the time required for the PID reference value to change from 0.0% to 100.0%.

When the PID reference changes, the PID set value changes linearly according to the reference change time, which reduces the adverse effect of the given sudden change on the system.

Function code	Item	Setting range	Factory default
F5-12	PID feedback filter time	0.00 ~ 60.00s	0.00s
F5-13	PID output filter time	0.00 ~ 60.00s	0.00s

F5-12 is used to filter the PID feedback amount, which is beneficial to reduce the influence of the feedback amount being disturbed, but it will bring about the degradation of the response performance of the process closed-loop system.

F5-13 is used to filter the PID output frequency, which will attenuate the sudden change of the frequency converter's output frequency, but it will also bring about a decline in the response performance of the process closed-loop system.

Function code	Item	Setting range	Factory default
F5-15	Proportional gain kP2	0.0 ~ 100.0	20.0
F5-16	Integral time Ti2	0.01s ~ 10.00s	2.00s
F5-17	Derivative time Td2	0.000s ~ 10.000s	0.000s
F5-18	PID parameter switching conditions	0: No switching 1: Switched via DI terminal 2: Auto switching via deviation	0

## 7. Details of Parameters

Function code	Item	Setting range	Factory default
F5-19	PID parameter switching deviation 1	0.0% ~ F5-20	20.0%
F5-20	PID parameter switching deviation 2	F5-19 ~ 100.0%	80.0%
F5-21	PID initial value	0.0% ~ 100.0%	0.0%
F5-22	PID initial value holding time	0.00 ~ 650.00s	0.00s

In some applications, a group of PID parameters cannot meet the requirements of the entire running process, and different PID parameters need to be used in different situations. This group of function codes is used for switching between two sets of PID parameters.

The setting mode of the regulator parameters F5-15 ~ F5-17 is similar to the parameters F5-05 ~ F5-07.

The two groups of PID parameters can be switched by the multi-function digital DI terminal, or can be automatically switched according to the deviation of the PID.

When the multi-function DI terminal is selected for switching, the multi-function terminal's function selection should be set to 43 (PID parameter switching terminal). When the terminal is invalid, select parameter group 1 (F5-05 ~ F5-07). When the terminal is valid, select the parameter group 2 (F5-15 ~ F5-17).

When automatic switching is selected, the absolute value of the deviation between the reference and the feedback is less than the PID parameter switching deviation 1 F5-19, and the PID parameter selects the parameter group 1. When the absolute value of the deviation between the reference and the feedback is greater than the PID switching deviation 2 F5-20, the PID parameter selection selects the parameter group 2. When the deviation between the reference and feedback is between the switching deviation 1 and the switching deviation 2, the PID parameter is the linear interpolation value of the two groups of PID parameters, as shown in Figure 7-28.

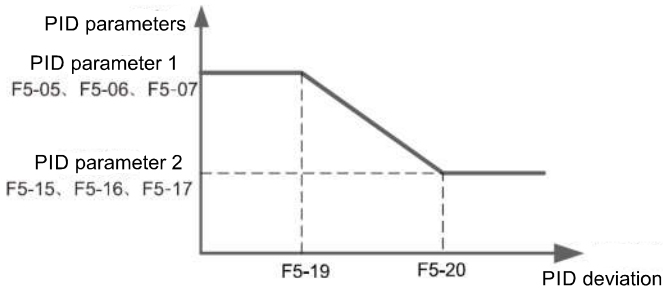


Fig. 7-28 PID parameter switching

Function code	Item	Setting range	Factory default
F5-23	Positive max value of two output deviations	0.00% ~ 100.00%	1.00%
F5-24	Negative max value of two output deviations	0.00% ~ 100.00%	1.00%

This function is used to limit the difference between PID output two beats (2ms/beat), so as to suppress the PID output from changing too fast, and the frequency converter's operation tends to be stable. F5-23 and F5-24 correspond to the maximum value of the absolute value of the output deviation in the forward and reverse directions, respectively.

Function code	Item	Setting range	Factory default
F5-25	PID integral properties	Ones place: integral separation 0: Ineffective 1: Effective Tens place: Does it stop integration after output reaches limit? 0: Continue integrating 1: Stop integrating	00

Integral separation: If the integral separation is set to be effective, when the multi-function digital DI integration pause (function 22) is valid, the integration of the PID stops the operation, and the PID only proportional and differential action is effective. When the integral separation selection is invalid, the integral separation is invalid regardless of whether the multi-function digital DI is valid or not. Whether to stop integration after output to the limit: After the PID operation output reaches the maximum or minimum value, you can choose whether to stop the integral action. If you choose to stop the integration, then the PID integration stops counting, which may help reduce the overshoot of the PID.

Function code	Item	Setting range	Factory default
F5-26	PID feedback loses detection value	0.0%: No judgment of feedback loss 0.1% ~ 100.0%	0.0%
F5-27	PID feedback loses detection time	0.0s ~ 20.0s	0.0s

This function code is used to judge whether the PID feedback is lost.

When the PID feedback amount is less than the feedback loss detection value F5-26, and the duration exceeds the PID feedback loss detection time F5-27, the frequency converter alarms the fault Err31 and processes according to the selected fault processing mode.

Function code	Item	Setting range	Factory default
F5-28	PID stop operation	0: No operating after stopping 1: Operating after stopping	0

It is used to select whether the PID continues to operate under the PID stop state. In general applications, the PID should stop operation in the shutdown state.

### 7.3.7 F6: Expansion functional parameters

Function code	Item	Setting range	Factory default
F6-00	Dormant frequency	0.00Hz ~ wake-up freq.(F6-02)	0.00Hz
F6-01	Dormant delay time	0.0s ~ 6500.0s	0.0s
F6-02	Wake-up frequency	Dormant freq. (F6-00) ~ Max freq. (F0-07)	0.00Hz
F6-03	Wake-up delay time	0.0s ~ 6500.0s	0.0s

This group of parameters is used to implement sleep and wake-up functions in water supply applications. During the running of the frequency converter, when the set frequency is less than or equal to the sleep frequency of F6-00, after the delay time of F6-01, the frequency converter enters the sleep state and stops automatically. If the frequency converter is in sleep state and the current running command is valid, when the set frequency is greater than or equal to the F6-02 wake-up frequency, the frequency converter will start after the delay time of F6-03. In general, please set the wake-up frequency to be greater than or equal to the sleep frequency. When the wake-up frequency and sleep frequency are both set to 0.00 Hz, the sleep and wake-up functions are invalid. When the sleep function is enabled, if the frequency source uses the PID, the sleep state PID is calculated. It is affected by the function code F5-28. At this time, the PID operation at stop (F5-28=1) must be selected.

**7.3.8 F7: Communication parameters**

Refer to appendix A Communication protocol

**7.3.9 F8: Protection and fault parameters**

Function code	Item	Setting range	Factory default
F8-00	Auto reset times of fault	0 ~ 20	0

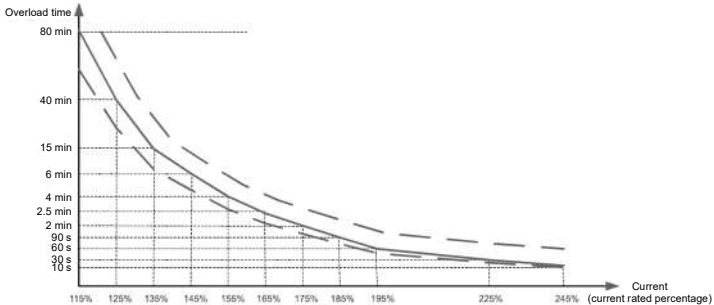
When the frequency converter selects fault automatic reset, it is used to set the number of times that can be automatically reset. After this number of times, the frequency converter remains in a fault state.

Function code	Item	Setting range	Factory default
F8-01	Auto reset interval of fault	0.1s ~ 100.0s	1.0s

Waiting time from frequency converter's fault alarm to automatic fault reset.

Function code	Item	Setting range	Factory default
F8-02	Motor's overload protection selection	0: Disenable 1: Enable	1
F8-03	Motor's overload protection gain	0.20 ~ 10.00	1.00

In order to effectively protect different load motors, it is necessary to set the parameters according to the motor's overload capability. The motor's overload protection is an inverse time curve, and the motor's overload protection curve is shown in Figure 7-29:



**Fig. 7-29 Diagram of inverse time curve of motor's overload protection**

- 1) Under the condition that the running current of the motor reaches 175% of the rated current of

the motor, the motor overload (Err11) is reported after 2 minutes of continuous operation. Under the condition that the running current of the motor reaches 115% of the rated current of the motor, the motor is overloaded after continuous operation for 80 minutes. Err11)

For example: motor's rated current 100A

If F8-03 is set to 1.00, when the motor's running current reaches 125% (125A) of 100A, the frequency converter will report motor overload fault after 40 minutes; if F8-03 is set to 1.20, then when the motor's running current reaches 125% (125A) of 100A, after  $40 \times 1.2 = 48$  minutes, the frequency converter reports motor overload fault. The maximum time is 80 minutes and the shortest time 10 seconds for overload.

2) Example of motor's overload protection adjustment: The motor needs to run for 2 minutes with 150% motor current to report the overload. According to the motor's overload curve, the current of 150% (I) is within current range of the 145% (I1) and 155% (I2). 145% of the current (T1) overloads in 6 minutes and 155% of the current (T2) overloads in 4 minutes, then the default setting of 150% of the motor's rated current overloads in 5 minutes, with the calculation as follows:

$$T = T1 + (T2 - T1) * (I - I1) / (I2 - I1) = 4 + (6 - 4) * (150\% - 145\%) / (155\% - 145\%) = 5 \text{ (minutes)}$$

Therefore, it can be concluded that the motor needs to be overloaded for 2 minutes under the condition of 150% motor current, and the motor's overload protection gain is:  $F8-03 = 2/5 = 0.4$

Note: The user needs to correctly set the value of F8-03 according to the actual overload capacity of the motor. If the parameter is set too large, the motor may be overheated and the frequency converter may not be alarmed in time!

3) The motor's overload warning coefficient indicates that when the motor's overload detection level reaches the set value of the parameter, the multi-function output terminal DO or the fault relay (RELAY) outputs a motor overload pre-alarm signal, and the parameter is continuously operated according to the motor at an overload point without reporting an overload fault of the percentage of time.

For example, when the motor's overload protection gain is set to 1.00 and the motor's overload warning coefficient is set to 80%, if the motor current reaches 145% of the rated motor current for 4.8 minutes ( $80\% * 6$  minutes), the multi-function output terminal DO or the fault relay outputs a motor overload warning signal.

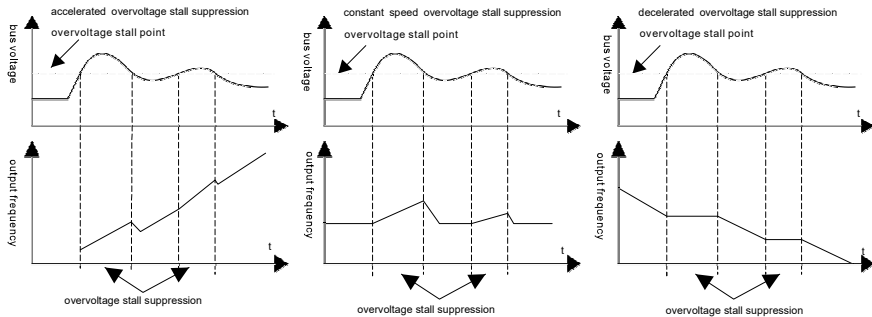
Function code	Item	Setting range	Factory default
F8-04	Overvoltage stall gain	0 ~ 100	0
F8-05	Overvoltage stall protection voltage	650.0V ~ 800.0V	770.0V

When the DC bus voltage exceeds the value of F8-05 (Overvoltage stall protective voltage) during deceleration of the AC drive, the AC drive stops deceleration and keeps the present running frequency. After the bus voltage declines, the AC drive continues to decelerate.

F8-04 (Overvoltage stall gain) is used to adjust the overvoltage suppression capacity of the AC drive. The larger the value is, the greater the overvoltage suppression capacity will be. In the prerequisite of no overvoltage occurrence, set F8-04 to a small value. For small-inertia load, the value should be small. Otherwise, the system dynamic response will be slow. For large-inertia load, the value should be large. Otherwise, the suppression result will be poor and an overvoltage fault may occur. If the overvoltage stall gain is set to 0, the overvoltage stall function is disabled.

Figure 7-30 Diagram of the overvoltage current stall protection function:

## 7. Details of Parameters



**Fig. 7-30 Diagram of overvoltage stall**

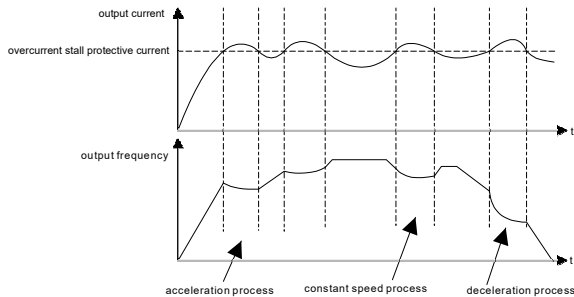
Function code	Item	Setting range	Factory default
F8-06	Overcurrent stall gain	0 ~ 100	20
F8-07	Overcurrent stall protection current	100% ~ 200%	150%

When the output current exceeds the overcurrent stall protective current during acceleration / deceleration of the AC drive, the AC drive stops acceleration/deceleration and keeps the present running frequency. After the output current declines, the AC drive continues to accelerate/decelerate.

F8-06 (Overcurrent stall gain) is used to adjust the overcurrent suppression capacity of the AC drive. The larger the value is, the greater the overcurrent suppression capacity will be. In the prerequisite of no overcurrent occurrence, set tF8-06 to a small value. For small-inertia load, the value should be small. Otherwise, the system dynamic response will be slow. For large-inertia load, the value should be large. Otherwise, the suppression result will be poor and overcurrent fault may occur.

If the overcurrent stall gain is set to 0, the overcurrent stall function is disabled.

Remarks: The overcurrent running current 150% represents 1.5 times the rated current of the inverter;



**Fig. 7-31 Diagram of overcurrent stall**

Function code	Item	Setting range	Factory default
F8-08	Power-on ground short circuit protection selection	0: Ineffective 1: Effective	0

The frequency converter can be selected to detect whether the motor is shorted to ground when it is powered on.

If this function is enabled, the UVW terminal of the frequency converter will have a voltage output for a period of time after power-on.



Function code	Item	Setting range	Factory default
F8-10	Fault DO action selection in auto reset period of fault	0: No action 1: Action	0

If the frequency converter's automatic fault reset function is enabled, the DO will be activated during the automatic fault reset, which can be set by F8-10.

Function code	Item	Setting range	Factory default
F8-11	Input phase loss protection selection	0: Disenable 1: Enable	1

Choose whether to protect the input phase loss or contactor pull-in.

Function code	Item	Setting range	Factory default
F8-12	Output phase loss protection selection	0: Disenable 1: Enable	1

Select whether to protect the output phase loss. If 0 is selected and the output phase loss occurs, the fault will not be reported. At this time, the actual current is larger than the current displayed by the panel. There is a risk and it should be used cautiously.

Function code	Item	Setting range	Factory default
F8-13	The 3rd (latest) fault type	0: No fault	-
F8-14	The 2nd fault type	1: Reserved 2: Accel overcurrent 3: Decel overcurrent 4: Constant speed overcurrent 5: Accel overvoltage 6: Decel overvoltage 7: Constant speed overvoltage 8: Buffer resistance overload 9: Undervoltage 10: Frequency converter overload 11: Motor overload 12: Input phase loss 13: Output phase loss 14: Module overheat 15: External fault 16: Comm. abnormal 17: Contactor abnormal 18: Current detection abnormal 19: Motor tuning abnormal 20: Function code/PG card abnormal 21: Parameter reading abnormal 22: Freq. converter abnormal 23: Motor grounding short circuit 26: Runtime reach 27: User-defined fault 1 28: User-define fault 2 29: Power-on time reach 30: Load drop 31: PID feedback loses during running 40: Fast current limiting times out	-

7. Details of Parameters

Function code	Item	Setting range	Factory default
F8-15	The 1st fault type	41: Switch motor during running 42: Speed deviation too large 43: Motor overspeed 44: Motor overtemperature 51: Initial position error 55: Load allocation slave fault	—
F8-16	Freq. at the 3rd (latest) fault	—	—

Record the latest three fault types of frequency converter, 0 represents no fault. For each fault code, please refer to the eighth chapter.

Function code	Item	Setting range	Factory default
F8-16 ~ F8-45	See the sixth chapter		
F8-46	Fault protection selection 1	Ones place: motor overload (Err11) 0: Free stop 1: Stop by stop mode 2: Continue running Tens place: Input phase loss (Err12) Hundreds place: Output phase loss (Err13) Thousands place: External fault (Err15) Ten thousands place: Comm. abnormal (Err16)	00000
F8-47	Fault protection selection 2	Ones place: Encoder/PG card abnormal (Err20) 0: Free stop Tens place: Function code reading & writing abnormal (Err21) 0: Free stop 1: Stop by stop mode Hundreds place: Reserved Thousands place: Motor overheat (Err25)( the same ones place as F8-46) Ten thousands place: Runtime reach (Err26)( the same ones place as F8-46)	00000

Function code	Item	Setting range	Factory default
F8-48	Fault protection selection 3	Ones place: User-defined fault 1 (Err27) 0: Free stop 1: Stop by stop mode 2: Continue running Tens place: User-defined fault 2 (Err28) 0: Free stop 1: Stop by stop mode 2: Continue running Hundreds place: Power-on time reach (Err29) 0: Free stop 1: Stop by stop mode 2: Continue running Thousands place: load drop (Err30) 0: Free stop 1: Decel stop 2: Decelerates to 7% of the motor's rated frequency and continues to run, automatically resumes to the set frequency when no load drop Ten thousands place: PID feedback loses when running (Err31) 0: Free stop 1: Stop by stop mode 2: Continue running	00000
F8-49	Fault protection selection 4	Ones place: Speed deviation too large (Err42) 0: Free stop 1: Stop by stop mode 2: Continue running Tens place: Motor overspeed (Err43) (same as F8-46 ones place) Hundreds place: Initial position error (Err51) (same as F8-46 ones place) Thousands place: Reserved Ten thousands place: Reserved	00000

When "Free Stop" is selected, the frequency converter displays Err\*\* and stops directly.

When "Stop by stop mode" is selected: the frequency converter displays A\*\* and stops according to the stop mode. After the stop, Err\*\* is displayed.

When "Continue to run" is selected: the frequency converter continues to run and displays A\*\*, and the running frequency is set by F8-53.

## 7. Details of Parameters

Function code	Item	Setting range	Factory default
F8-53	Selection of frequency to continue running when fault occurs	0: Run with the current freq. 1: Run with the set freq. 2: Run with the upper limit freq. 3: Run with the lower limit freq. 4: Run with the abnormal standby freq.	0
F8-54	Abnormal standby freq.	0.0% ~ 100.0% (100% corresponds to max freq F0-07)	100.0%

When a fault occurs during the operation of the frequency converter, and the fault is set to continue running, the frequency converter displays A\*\*, and runs at the frequency determined by F8-53.

When selecting abnormal backup frequency, the value set by F8-54 is the percentage relative to the maximum frequency.

Function code	Item	Setting range	Factory default
F8-55	Motor overheat protection threshold	0°C ~ 200°C	110°C
F8-56	Motor overheat warning threshold	0°C ~ 200°C	90°C

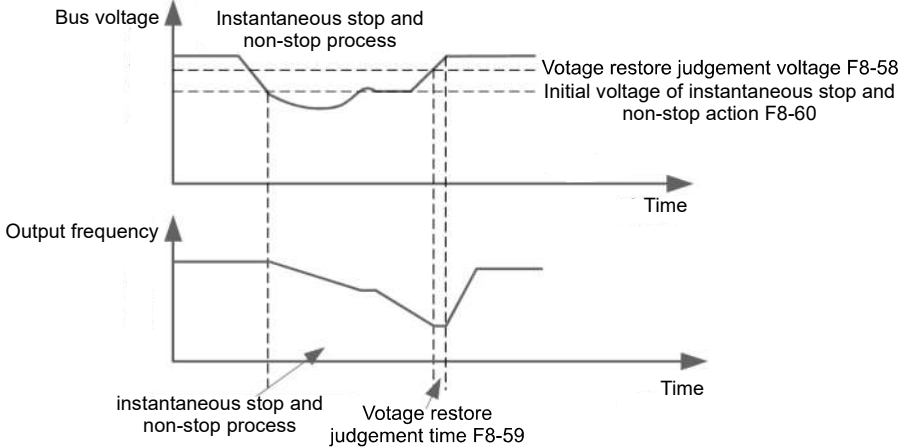
The temperature signal of the motor's temperature sensor needs to be connected to the multi-function I/O expansion card. This card is an optional accessory. The analog input AI3 of the expansion card can be used as the motor's temperature sensor input, and the motor's temperature sensor signal is connected to the AI3 and PGND terminals. AI3 analog input terminal, support PT100 and PT1000 two kinds of motor temperature sensor, the sensor type must be set correctly when using. The motor's temperature value is displayed in d0-34. When the motor's temperature exceeds the motor's overheat protection threshold F8-55, the frequency converter fault alarms and is processed according to the selected fault protection action mode. When the motor's temperature exceeds the motor's overheat pre-alarm threshold F8-56, the frequency converter's multi-function digital DO outputs motor over-temperature pre-alarm ON signal.

Function code	Item	Setting range	Factory default
F8-57	Instant power-off action selection	0: Ineffective 1: Accel 2: Decel stop	0
F8-58	Instant action pause judgment voltage	80.0%~100.0%	90.0%
F8-59	Instant power-off voltage recovery judgment time	0.00s ~ 100.00s	0.50s
F8-60	Instant power-off action judgment voltage	60.0%~100.0% (standard bus voltage)	80.0%

As shown in Figure 7-32: When the bus voltage drops below the "instantaneous stop and non-stop action judgment voltage", the instantaneous stop and non-stop process takes effect, the frequency converter's output frequency automatically drops to make the motor in the power generation state, and the instantaneous stop and non-stop function can make electric energy fed back to the bus voltage maintained around the "instantaneous stop and non-stop judgment voltage", and make the system normally decelerate to 0 Hz.

Remarks: (1) When the bus voltage is constant, after the grid resumes power supply, the frequency converter's output frequency continues to run to the target frequency. In the deceleration stop mode, after the grid resumes power supply, the frequency converter continues to decelerate to 0Hz until it re-issues START command.

(2) The purpose of instantaneous stop and non-stop is to ensure that when the power supply of the power grid is abnormal, the motor can be decelerated and stopped normally, so that the motor can be started immediately after the grid is restored to normal power supply, and the motor will not suddenly stop freely due to undervoltage when the power supply in the grid is abnormal. In the large inertia system, the motor can take a long time to freely stop. When the power supply is normal, it is prone to cause overload or overcurrent fault by starting the frequency converter because the motor is rotating at high speed



**Fig. 7-32 Diagram of instantaneous stop and non-stop process**

Function code	Item	Setting range	Factory default
F8-61	Load drop protection selection	0: Ineffective 1: Effective	0
F8-62	Load drop detection level	0.0 ~ 100.0%	10.0%
F8-63	Load drop detection time	0.0 ~ 60.0s	1.0s

If the load-dropping protection function is valid, when the frequency converter's output current is less than the load-dropping detection level F8-62 and the duration is greater than the load-dropping detection time F8-63, the frequency converter's output frequency automatically reduces to 7% of the rated frequency. During load-dropping protection, if the load recovers, the frequency converter automatically returns to run at the set frequency.

Function code	Item	Setting range	Factory default
F8-65	Overspeed detection value	0.0% ~ 50.0% (max frequency)	20.0%
F8-66	Overspeed detection time	0.0s ~ 60.0s	5.0s

This function is only available when the frequency converter is running with speed sensor vector control. When the frequency converter detects that the actual speed of the motor exceeds the maximum frequency. The outgoing value is greater than the over speed detection value F8-65, and

## 7. Details of Parameters

duration is greater than the speed detection time F8-66. the frequency converter will alarm fault Err42 and process it according to the fault protection mode. When the over speed detection time is 0.0s, the over speed fault detection will be canceled.

Function code	Item	Setting range	Factory default
F8-67	Detection value when speed deviation is too large	0.0% ~ 50.0% (max frequency)	20.0%
F8-68	Detection time when speed deviation is too large	0.0s ~ 60.0s	5.0s

This function is only available when the frequency converter is running with speed sensor vector control. When the frequency converter detects that the actual speed of the motor deviates from the set frequency, the deviation amount is greater than the speed deviation excessive detection value F8-67, and the duration is greater than the speed deviation excessive detection time F8-68, the frequency converter will alarm fault Err42 and process it according to the fault protection mode. When the speed deviation is too large and the detection time is 0.0s, the speed deviation excessive fault detection will be canceled.

Function code	Item	Setting range	Factory default
F8-69	Radiator's temp of inverter module	0.1℃	
F8-70	Radiator's temp of rectifier bridge	0.1℃	

It is used to display the temperature of the frequency converter's module IGBT. The inverter IGBT's over-temperature protection values vary for different models.

## 7.4 Group P: Operating panel's parameters

### 7.4.1 P0: Universal keyboard's parameters

Function code	Item	Setting range	Factory default
P0-00	MFK key's function selection	0: MFK ineffective 1: Switching between operation panel command channel and remote command channel (terminal command channel or comm. command channel) 2: Switching between FWD and REV 3: FWD jogging 4: REV jogging 5: Switching of modified parameter list	0

The MFK button is a multi-function button, and the function of the MFK button can be set by this function code.

This button can be used to switch between stop and run.

0: This button has no function.

1: Switching between keyboard commands and remote operations. It refers to the switching of the command source, that is, switching between the current command source and keyboard control (local operation). If the current command source is from keyboard control, this key function is invalid.

2: Forward and reverse switching. The direction of the frequency command is switched by the MFK key.

This function is only available when the command source is the operator panel command channel.

3: Forward jog. Forward jog (FJOG) is realized by the MFK key on the keyboard.

4: Reverse jog. Reverse jog (RJOG) is realized by the keyboard MFK key.

5: Switching of modified parameter list. Parameter switching is possible.

Function code	Item	Setting range	Factory default
P0-01	Stop/reset key's function	0: Stop/reset key's stop function affects only in keyboard operation mode 1: Stop/reset key's stop function affects in any operation mode	1

P0-01 realizes stop reset button function.

Function code	Item	Setting range	Factory default
P0-02	Load speed display coefficient	0.0001 ~ 6.5000	1.0000

When the load speed needs to be displayed, adjust the corresponding relationship between the output frequency of the frequency converter and the load speed through this parameter. Refer to the description of P0-03 for the specific corresponding relationship.

Function code	Item	Setting range	Factory default
P0-03	Load speed displays decimal places	0: 0 decimal place 1: 1 decimal place 2: 2 decimal places 3: 3 decimal places	1

It is used to set the number of decimal places for the load speed display.

The following is an example of the calculation of the load speed: if the load speed display coefficient P0-02 is 2.000, the load speed's decimal point P0-03 is 2 (2 decimal places), when the frequency converter's running frequency is 40.00Hz, the load speed is:  $40.00 \times 2.0000 = 80.00$  (2 decimal places are displayed).

If the frequency converter is in the stop state, the load speed is displayed as the speed corresponding to the set frequency, that is, "set load speed". Taking the set frequency of 50.00 Hz as an example, the load speed in the stop state is  $50.00 \times 2.0000 = 100.00$  (2 decimal places are displayed)

#### 7.4.2 P1: LED keyboard's parameters

Run display parameters are used to set the parameters that can be viewed when the frequency converter is running. The maximum number of status parameters that can be viewed is 32. According to the P1-00 and P1-01 parameter values, the status parameters to be displayed are selected. The display order starts from the lowest bit of P1-00.

7. Details of Parameters

Function code	Item	Setting range	Factory default
P1-00	LED running display parameters 1	0000 ~ FFFF Bit00: Running frequency (Hz) Bit01: Set frequency (Hz) Bit02: Bus voltage (V) Bit03: Output voltage (V) Bit04: Output current (A) Bit05: Output power (kW) Bit06: Output torque (%) Bit07: DI input state Bit08: DO output state Bit09: AI1 voltage (V) Bit10: AI2 voltage (V) Bit11: AI3 voltage (V) Bit12: Count value Bit13: Length value Bit14: Load speed display Bit15: PID setting	H.001F
P1-01	LED running display parameters 2	0000~FFFF Bit00: PID feedback Bit01: PLC stage Bit02: PULSE input pulse freq (kHz) Bit03: Running freq 2 (Hz) Bit04: Remaining runtime Bit05: AI1 pre-correction voltage (V) Bit06: AI2 pre-correction voltage (V) Bit07: AI3 pre-correction voltage (V) Bit08: Linear speed Bit09: Current power-on time (hour) Bit10: Current runtime (min) Bit11: PULSE input pulse freq (Hz) Bit12: Comm. set value Bit13: Encoder feedback speed (Hz) Bit14: Main freq. X display (Hz) Bit15: Aux freq. Y display (Hz)	H.0000



Function code	Item	Setting range	Factory default
P1-02	LED stop display parameters	0000~FFFF Bit00: Set frequency (Hz) Bit01: Bus voltage (V) Bit02: DI state Bit03: DO state Bit04: AI1 voltage (V) Bit05: AI2 voltage (V) Bit06: AI3 voltage (V) Bit07: Count value Bit08: Length value Bit09: PLC stage Bit10: Load speed Bit11: Pulse input freq. (kHz) Bit13-15: Reserved	H.0033

## 7.5 Group A: Application software's parameters

### 7.5.1 A0: Swing frequency, fixed length and count

Function code	Item	Setting range	Factory default
A0-00	Swing frequency setting mode	0: Relative to the center freq. 1: Relative to the max freq.	0

This parameter is used to determine the reference amount of the swing.

0: Relative to the center frequency (F0-05 frequency source), it is a variable swing system.

The swing varies with the center frequency (set frequency).

1: Relative maximum frequency (F0-07), for a fixed swing system, the swing is fixed.

Function code	Item	Setting range	Factory default
A0-01	Swing frequency amplitude	0.0% ~ 100.0%	0.0%
A0-02	Startup frequency amplitude	0.0% ~ 50.0%	0.0%

This parameter is used to determine the value of the swing value and the kick frequency.

When setting the swing relative to the center freq. (A0-00=0), swing AW = freq. source F0-05 X swing A0-01.

When setting the swing relative to the max freq. (A0-00=1), swing AW = the max freq. F0-07 X swing A0-01.

When the kick frequency amplitude is the swing frequency operation, the kick frequency relative to the percentage of frequency of the swing:

Kick frequency = swing AW X kick frequency amplitude A0-02.

If the swing is selected relative to the center freq. (A0-00 = 0), the kick frequency is a change value.

If the swing is selected relative to the max freq. (A0-00 = 1), the kick frequency is a fixed value. The swing frequency is limited by the upper and lower frequencies.

## 7. Details of Parameters

Function code	Item	Setting range	Factory default
A0-03	Swing frequency period	0.1s ~ 3000.0s	10.0s
A0-04	Triangular wave rise time of swing frequency	0.1% ~ 100.0%	50.0%

Triangular wave fall time = swing freq. period A0-03 X (1 - triangular wave rise time coefficient A0-04), measured in seconds.

The triangular wave rise time coefficient A0-04 is the time percentage of the triangular wave rise time relative to the swing frequency period A0-03. Triangle wave rise time = swing frequency period A0-03 X triangular wave rise time coefficient A0-04, measured in seconds.

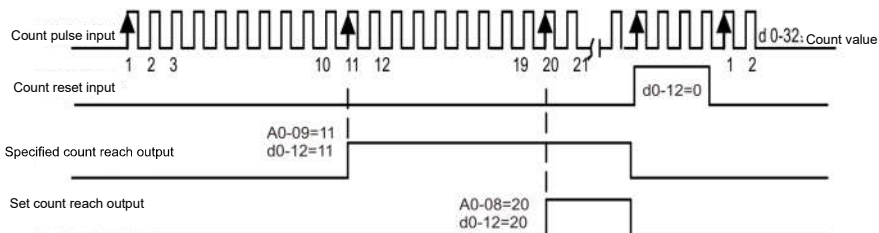
Function code	Item	Setting range	Factory default
A0-05	Fixed length	0m ~ 65535m	1000m
A0-06	Actual length	0m ~ 65535m	0m
A0-07	Pulse number per meter	0.1 ~ 6553.5	100.0

The above function code is used for fixed length control. The length information needs to be collected through the multi-function digital input terminal. The number of pulses sampled by the terminal is divided by the number of pulses per meter A0-07, and the actual length A0-06 can be calculated. When the actual length is greater than the set length A0-05, the multi-function digital DO outputs the "length reached" ON signal. During the fixed length control, the length reset can be performed through the multi-function DI terminal (the DI function is selected as 28). For details, please refer to F1-00 ~ F1-09.

In the application, the corresponding input terminal function needs to be set to "length count input" (function 27). When the pulse frequency is high, the DI5 port must be used.

Function code	Item	Setting range	Factory default
A0-08	Set count value	1 ~ 65535	1000
A0-09	Designated count value	1 ~ 65535	1000

The count value needs to be collected through the multi-function digital input terminal. In the application, the corresponding input terminal function needs to be set to "counter input" (function 25). When the pulse frequency is high, the DI5 port must be used. When the count value reaches the set count value A0-08, the multi-function digital DO outputs the "set count value reached" ON signal, and then the counter stops counting. When the count value reaches the specified count value A0-09, the multi-function digital DO outputs the "specified count value reached" ON signal, at which time the counter continues to count until the "set count value" is stopped. The specified count value A0-09 should not be greater than the set count value A0-08. Figure 7-33 shows the function of setting the count value reached and the specified count value reach function.



**Fig. 7-33 Diagram of set count value reference and specified count value reference**

## 7.5.2 A2: virtual IO

Function code	Item	Setting range	Factory default
A2-00	Virtual VDI1 terminal function selection	0 ~ 59	0
A2-01	Virtual VDI2 terminal function selection	0 ~ 59	0
A2-02	Virtual VDI3 terminal function selection	0 ~ 59	0
A2-03	Virtual VDI4 terminal function selection	0 ~ 59	0
A2-04	Virtual VDI5 terminal function selection	0 ~ 59	0

The virtual VDI1-VDI5 is identical in function to the DI on the control panel and can be used as a multi-function digital input. For detailed settings, please refer to the introduction of F1-00~F1-09.

Function code	Item	Setting range	Factory default
A2-05	Virtual VDI terminal state setting mode	Ones place: Virtual VDI1 0: Whether VDI is effective by the state of virtual VDOx 1: Whether VDI is effective by the setting of function code A2-06 Tens place: Virtual VDI2 (0 ~ 1) Hundreds place: Virtual VDI3 (0 ~ 1) Thousands place: Virtual VDI4 (0 ~ 1)	00000
A2-06	Virtual VDI terminal state setting	Ones place: Virtual VDI1 0: Ineffective 1: effective Tens place: Virtual VDI2 (0 ~ 1) Hundreds place: Virtual VDI3 (0 ~ 1) Thousands place: Virtual VDI4 (0 ~ 1) Ten thousands place: Virtual VDI5 (0 ~ 1)	00000

Unlike the normal digital input terminals, the status of the virtual VDI can be set in two ways and selected by A2-05. When the VDI state is selected to be determined by the state of the corresponding virtual VDO, whether VDI is valid depends on whether the VDO output is valid or invalid, and VDIx is uniquely bound to VDOx (x is 1~5). When the VDI status is set by the function code, the status of the virtual input terminal is determined by the binary bit of function code A2-06. The following is an example of how to use virtual VDI.

Example 1: When the VDO status is selected to determine the VDI status, the following functions are to be completed: "When the AM input exceeds the upper and lower limits, the frequency converter gives fault alarm and stops", the following setting method can be used: Set the function of VDI1 to "user-defined fault 1" (A2- 00=44); Set the VDI1 terminal valid status mode to be determined by VD01 (A2-05=xxxx0); Set the VD01 output function to "AI1 input exceeds the upper and lower limits" (A2-11=31), then when the AI1 input exceeds the upper and lower limits, the VD01 output is ON. At this time, the VDI1 input terminal status is valid. When the frequency converter's VDI1 receives the user-defined fault 1, it will give fault alarm Err27 and stop.

7. Details of Parameters

Example 2: When the function code A2-06 is selected to set the VDI state, you need to complete the following functions: “Automatically enter the running state after the frequency converter is powered on”, you can use the following setting method: set the function of VDI1 to “forward running” (A2-00=1); Set VDI1 terminal valid status mode to be set by function code (A2-05=xxxx1); Set VDI1 terminal status to valid (A2-06=xxxx 1); Set command source to “terminal control” (F0-00=1); Set the start protection selection to “No protection” (F0-27=0); After the frequency converter is powered on and initialized, it is detected that VDI1 is valid, and this terminal corresponds to forward running, which is equivalent to that the frequency converter receives a terminal forward run command, then the frequency converter will start running forward.

Function code	Item	Setting range	Factory default
A2-07	Function selection when AI1 terminal serves as DI	0 ~ 59	0
A2-08	Function selection when AI2 terminal serves as DI	0 ~ 59	0
A2-09	Function selection when AI3 terminal serves as DI	0 ~ 59	0
A2-10	Effective mode selection when AI terminal serves as DI	0: High level effective 1: Low level effective Ones place: AI1 Tens place: AI2 Hundreds place: AI3	000

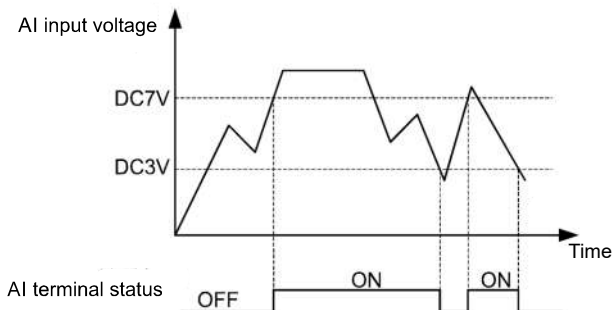


Fig. 7-34 Judgment of AI terminal's status

This group of function codes is used to use AI as DI. When AI is used as DI, the AI terminal state is high level when the AI voltage is greater than 7V, and the AI terminal state is low level when the AI voltage is lower than 3V. The hysteresis loop between 3V and 7V is used to determine whether AI's high level is valid or low level is valid when AI is used as DI. As for the function setting when AI is used as DI, it is the same as the normal DI setting, please refer to the description of the relevant DI setting. Figure 7-34 shows the relationship between the AI voltage and the corresponding DI state by taking the AI voltage as an example.

Function code	Item	Setting range	Factory default
A2-11	Virtual VDO1 output function selection	0: Internal short circuit with physical Dix 1 ~ 41: See group F2 physical DO output selection	0

Function code	Item	Setting range	Factory default
A2-12	Virtual VDO2 output function selection	0: Internal short circuit with physical Dix 1 ~ 41: See group F2 physical DO output selection	0
A2-13	Virtual VDO3 output function selection	0: Internal short circuit with physical Dix 1 ~ 41: See group F2 physical DO output selection	0
A2-14	Virtual VDO4 output function selection	0: Internal short circuit with physical Dix 1 ~ 41: See group F2 physical DO output selection	0
A2-15	Virtual VDO5 output function selection	0: Internal short circuit with physical Dix 1 ~ 41: See group F2 physical DO output selection	0
A2-16	VDO1 output delay time	0.0s ~ 3600.0s	0.0s
A2-17	VDO2 output delay time	0.0s ~ 3600.0s	0.0s
A2-18	VDO3 output delay time	0.0s ~ 3600.0s	0.0s
A2-19	VDO4 output delay time	0.0s ~ 3600.0s	0.0s
A2-20	VDO5 output delay time	0.0s ~ 3600.0s	0.0s
A2-21	VDO output terminal's effective state selection	Ones place: VDO1 0: Positive logic 1: Negative logic Tens place: Virtual VDO2 (0 ~ 1) Hundreds place: Virtual VDO3 (0 ~ 1) Thousands place: Virtual VDO4(0 ~ 1) Ten thousands place: Virtual VDO5 (0 ~ 1)	00000

The virtual digital output function, similar to the control board DO function, can be used with the virtual digital input VDIX to achieve some simple logic control. When the virtual VDOx output function is selected as 0, the output state of VDO1-VDO5 is determined by the DM-DI5 input state on the control board. At this time, VDOx and Dix are one-to-one. When the virtual VDOx output function is selected to be non-zero, the function setting and usage of VDOx are the same as those related to the DO. The same VDOx output valid state can be selected from positive or negative logic, set by A2-21. The user can check whether the current VDOX status is valid through d0-08. The VDIX application example includes the use of VDOx, please refer to it.

7

## 7.6 Group U: Optional card's parameters

### 7.6.1 U0: User- programmable card's parameters

## 7. Details of Parameters

Function code	Item	Setting range	Factory default
U0-00	Comm. expansion card type	0: None 1: Profibus-DP comm. card 2: CANopen comm. Card 3: PLC card 4: PLC card( Frequency given by MODBUS) 5: EtherCAT comm. Card	0

XFC550 uses the serial port to realize four communication protocols: PFB 、 CAN 、 PLC and ECT card. when U0-00 is 3 or 4, we can operate the PLC card. when the frequency is given by PLC card, we should set U0-00 to 3; when the frequency is given by MODBUS, we should set U0-00 to 4; all of the protocols only support the use of one of them at the same time. Please set this parameter correctly according to actual needs.

Function code	Item	Setting range	Factory default
U0-01	CANopen slave station address setting	1~63	1

Through U0-01 choose the slave station address of CANopen communication.

Function code	Item	Setting range	Factory default
U0-03	Control mode selection of control board's output terminal	0: Controlled by frequency converter 1: Controlled by user programmable control card Ones place: pulse (DO2 terminal serves as pulse output) Tens place: relay (TA-TB-TC) Hundreds place: DO1 Thousands place: on-off value (DO2 terminal serves as on-off output) Ten thousands place: AO1	00000

When the user-programmable function is valid, the control source of the output terminal is set to the frequency converter itself or the programmable card's user program control.

Function code	Item	Setting range	Factory default
U0-05	Pulse output	0.0% ~ 100.0%	0.0%

When the pulse output terminal control source is PLC, the actual output value of the pulse output terminal is set in U0-04 (the user-programmable card realizes the control of the pulse output by changing the value of U0-04).

Function code	Item	Setting range	Factory default
U0-06	AO1 output	0.0% ~ 100.0%	0.0%

When the AO1 output terminal control source is PLC, the actual output value of AO1 is set in U0-05 (the user-programmable card realizes the control of AO1 output by changing the value of U0-05).

Function code	Item	Setting range	Factory default
U0-07	On-off output	Binary system setting Ones place: on-off value Tens place: relay 1 Hundreds place: DO	001

When PLC is the source of digital output terminal's on-off value, relay 1, DO control, the digital output terminal status is set by U0-06 (user-programmable card program directly controls the on-off value, relay 1, DO1 through control elements Y2, Y3, Y4 )

## 7.7 Group d: Monitor parameters

The group d0 parameters are used to monitor the running status of the frequency converter. You can view it through the panel to facilitate on-site debugging. You can also read the parameter value through communication for monitoring the host computer. The communication address is 0x7000~0x7044.

Function code	Item	Display range
d0-00	Running frequency (Hz)	0.00 ~ 500.00Hz
d0-01	Set frequency (Hz)	0.00 ~ 500.00Hz

It is used to display the theoretical running frequency of the frequency converter and the absolute value of the set frequency.

The actual output frequency of the frequency converter is shown in d0-19

Function code	Item	Display range
d0-02	Bus voltage (V)	0.0 ~ 3000.0V

It is used to display the frequency converter's bus voltage value.

Function code	Item	Display range
d0-03	Output voltage (V)	0 ~ 1140V

It is used to display the frequency converter's output voltage during running.

Function code	Item	Display range
d0-04	Output current (A)	0.00A ~ 655.35A (freq. power=55kW) 0.0A ~ 6553.5A (freq. power>55kW)

It is used to display the frequency converter's output current during running.

Function code	Item	Display range
d0-05	Output power (kW)	0 ~ 3276kW

It is used to display the frequency converter's output power during running.

Function code	Item	Display range
d0-06	Output torque (%) motor rated percentage output value	-200.0% ~ 200.0%

It is used to display the frequency converter's output torque during running.

Function code	Item	Display range
d0-07	DI state	0 ~ 32767

It is used to display the current DI terminal input status value. After being converted to binary data, each Bit corresponds to a DI signal, with a value of 1 indicating that the input is a high level signal and a value of 0 indicating that the input is a low level signal. The correspondence between each bit and the input terminal is as follows:

Bit0	Bit1	Bit2	Bit3	Bit4	Bit5	Bit6	Bit7
DI1	DI2	DI3	DI4	DI5	DI6	DI7	DI8
Bit8	Bit9	Bit10	Bit11	Bit12	Bit13	Bit14	Bit15
DI9	DI10	VDI1	VDI2	VDI3	VDI4	VDI5	-

Function code	Item	Display range
d0-08	DO state	0 ~ 1023

## 7. Details of Parameters

It is used to display the current DO terminal input status value. After being converted to binary data, each Bit corresponds to a DO signal, with a value of 1 indicating that the input is a high level signal and a value of 0 indicating that the input is a low level signal. The correspondence between each bit and the input terminal is as follows:

Bit0	Bit1	Bit2	Bit3	Bit4	Bit5
DO2	Relay 1	Relay 2	DO1	DO3	VDO1
Bit6	Bit7	Bit8	Bit9	Bit10	Bit11
VDO2	VDO3	VDO4	VDO5		

Function code	Item	Display range
d0-14	Load speed display	0 ~ 65535

The display value is shown in description of P0-03.

Function code	Item	Display range
d0-15	PID setting	0 ~ 65535
d0-16	PID feedback	0 ~ 65535

It is used to display the PID set value and feedback value. The value format is as follows: PID setting = PID setting (percentage) \* F5-04; PID feedback = PID feedback (percentage) \* F5-04.

Function code	Item	Display range
d0-18	PULSE input pulse frequency (Hz)	0.00kHz ~ 100.00kHz

It is used to display DI5 high-speed pulse sampling frequency, the minimum unit is 0.01KHz.

Function code	Item	Display range
d0-19	Feedback speed (Hz)	0.00Hz ~ 500.00Hz

It is used to display the frequency converter's actual output frequency.

Function code	Item	Display range
d0-20	Remaining runtime	0.0~6500.0min

It is used to the remaining run time during the timing run. See the description of parameters F2-43 ~ F2-45 for the timing run.

Function code	Item	Display range
d0-21	AI1 voltage before correction	0.000V ~ 10.570V
d0-22	AI2 voltage(V)/current (mA) before correction	0.000V ~ 10.570V 0.000mA ~ 20.000mA
d0-23	AI3 voltage before correction	-10.570V ~ 10.570V

It is used to display the actual value of the analog input sampled voltage/current. The actual voltage/current used has been linearly corrected so that the sampled electrical torsional current and the actual input voltage/actually used correction voltage/current are seen in d0-09, d0-10, and d0-11. See the group F3 for the correction method.

Function code	Item	Display range
d0-24	Linear speed	0 ~ 6553m/min

It is used to display the linear speed of DI5 high-speed pulse sampling, the unit is m/min. Calculate the linear speed value according to the actual number of pulses per minute and A0-07 (pulse per meter).

Function code	Item	Display range
d0-27	Current power-on time	0 ~ 65535Hz

It is used to display the DI5 high-speed pulse sampling frequency in units of 1 Hz. The same data as d0-18, only the units displayed are different.



Function code	Item	Display range
d0-28	Comm. set value	-100.00% ~ 100.00%

It is used to display the data written by the communication address 0x1000.

Function code	Item	Display range
d0-29	Encoder feedback speed	0.00 ~ 500.00Hz

It is used to display the motor's running frequency actually measured by the encoder.

Function code	Item	Display range
d0-30	Main freq. X display	0.00 ~ 500.00Hz

It is used to display the frequency setting of main frequency source X.

Function code	Item	Display range
d0-31	Aux freq. Y display	0.00 ~ 500.00Hz

It is used to display the frequency setting of auxiliary frequency source Y.

Function code	Item	Display range
d0-34	motor's temperature	0°C ~ 200°C

It is used to display the motor's temperature value sampled by AI3. Motor's temperature detection can be found in C0-16.

Function code	Item	Display range
d0-35	Target torque (%)	-200.0% ~ 200.0%

It is used to display the upper limit set value of the current torque.

Function code	Item	Display range
d0-36	Resolver position	0 ~ 4095

It is used to display the position signal of the resolver.

Function code	Item	Display range
d0-37	Power factor angle	0.0° ~ 359.9°

It is used to display the current power factor angle.

Function code	Item	Display range
d0-38	ABZ position	0 ~ 65535

It is used to display the current ABZ or UVW encoder AB phase pulse count.

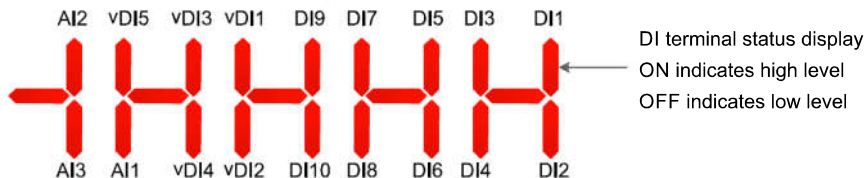
The value is the number of pulses after 4 times of frequency. If 4000 is displayed, the number of pulses actually passed by the encoder is  $4000/4=1000$ . This value is self-increasing when the encoder is rotating forward. When the encoder is reversed, the value is decremented. When it is increased to 65535, it restarts counting from 0. When it is reduced to 0, 65535 starts counting again. Check this value to determine if the encoder is installed properly.

Function code	Item	Display range
d0-39	VF separation target voltage	0V ~ rated voltage of motor
d0-40	VF separation output voltage	0V ~ rated voltage of motor

It is used to display the target output voltage and the current actual output voltage when running in the VF separation state. See the related introduction of group C5 for VF separation.

Function code	Item	Display range
d0-41	DI state visual display	-

It is used to visually display the status of the DI terminal, and its display format is as follows:



Function code	Item	Display range
d0-42	DO state visual display	-

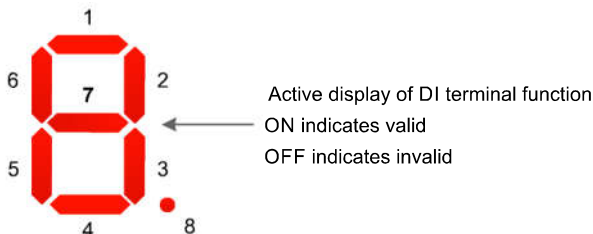
It is used to visually display the status of the DO terminal, and its display format is as follows:



Function code	Item	Display range
d0-43	DI function state visual display1	-

It is used to visually display whether the terminal functions 1 to 40 are valid. The keyboard has 5 digital tubes, and each digital tube display can represent 8 function options.

The definition of digital tubes is as follows:



The digital tubes represent functions 1 ~ 8, 9 ~ 16, 17 ~ 24, 25 ~ 32, and 33 ~ 40 from right to left.

Function code	Item	Display range
d0-44	DI function state visual display2	-

It is used to visually display whether the terminal functions 41 ~ 59 are valid.

The display is similar to d0-43.

The digital tubes represent functions 41 ~ 48, 49 ~ 56, 57 ~ 59 from right to left.

Function code	Item	Display range
d0-58	Z signal counter	0~65535

It is used to display the current ABZ or UWW encoder Z-phase pulse count.

When the encoder rotates forward or reversely for one turn, the corresponding value is incremented or decremented by 1. Check the value to check if the encoder is installed properly.

Function code	Item	Display range
d0-59	Set frequency (%)	-100.00%~100.00%
d0-60	Running frequency (%)	-100.00%~100.00%

It is used to display the current set frequency and running frequency, 100.00% corresponds to the maximum frequency of the frequency converter (F0-07).

Function code	Item	Display range
d0-61	Frequency converter's state	0 ~ 65535

It is used to display the running status of the frequency converter, and definition format is as follows:

d0-61	Bit 0	0: Stop
	Bit 1	1: FWD 2: REV
	Bit 2	0: Constant
	Bit 3	1: Accel 2: Decel
	Bit 4	0: Bus voltage normal 1: Undervoltage

Function code	Item	Display range
d0-62	Current fault code	0 ~ 99

It is used to display the current fault code.

Function code	Item	Display range
d0-63	Point-to-point comm. sending value	-100.00% ~ 100.00%
d0-64	Number of slave station	0 ~ 63

It is used to display the communication data when the point-to-point communication is valid. d0-63 is the data value sent by the host, and d0-64 is the master station which shows the number of online slaves.

Function code	Item	Display range
d0-65	Upper limit of torque	-200.00% ~ 200.00%

It is used to display the upper limit of set torque.

## 8. Fault Diagnosis and Troubleshooting

When the XFC550 frequency converter system fails during operation, the frequency converter will immediately protect the motor from output and the frequency converter's fault relay contact will act. The fault code will be displayed on the frequency converter's panel. The fault types and common solutions for fault codes are detailed in the table below. The list is for reference only. Please do not repair or restructure the frequency converter randomly. If you cannot solve the problem, please contact our company or product agent for technical support.

After troubleshooting, there are several ways to reset the fault.

1. Reset by operating panel
2. Reset by external reset terminal
3. Reset by communication mode
4. Power off the frequency converter and then power on again

### 8.1 Fault

Fault	Code displayed on operating panel	Cause of fault	Troubleshooting
Inverter unit protection	Err01	<ol style="list-style-type: none"> <li>1. The frequency converter's output circuit is shorted.</li> <li>2. The wiring of motor and frequency converter is too long.</li> <li>3. The module is overheated.</li> <li>4. The internal wiring of the frequency converter is loose.</li> <li>5. The main control board is abnormal.</li> <li>6. The drive board is abnormal.</li> <li>7. The inverter module is abnormal.</li> </ol>	<ol style="list-style-type: none"> <li>1. Remove peripheral faults.</li> <li>2. Install reactor or output filter.</li> <li>3. Check if the air duct is blocked and the fan is working properly. If yes, remove the problems.</li> <li>4. Plug in all the cables.</li> <li>5. Seek for technical support.</li> <li>6. Seek for technical support.</li> <li>7. Seek for technical support.</li> </ol>

Fault	Code displayed on operating panel	Cause of fault	Troubleshooting
Acceleration overcurrent	Err02	<ol style="list-style-type: none"> <li>1. The output circuit of the frequency converter is grounded or shorted.</li> <li>2. The vector control mode without parameter tuning.</li> <li>3. The acceleration time is too short.</li> <li>4. Manual torque boost or VF curve is not suitable.</li> <li>5. The voltage is low.</li> <li>6. Start the motor that is rotating</li> <li>7. Sudden loading during acceleration.</li> <li>8. The power of the model is small.</li> </ol>	<ol style="list-style-type: none"> <li>1. Remove peripheral faults.</li> <li>2. Perform motor's parameter tuning.</li> <li>3. Increase the acceleration time.</li> <li>4. Adjust manual boost torque or V/F curve</li> <li>5. Adjust the voltage to the normal range</li> <li>6. Select the speed tracking restart or wait for the motor to stop and then start.</li> <li>7. Cancel the sudden load.</li> <li>8. Select the model with a larger power.</li> </ol>
Deceleration overcurrent	Err03	<ol style="list-style-type: none"> <li>1. The output circuit of the frequency converter is grounded or shorted.</li> <li>2. The vector control mode without parameter tuning.</li> <li>3. The deceleration time is too short.</li> <li>4. The voltage is low.</li> <li>5. Sudden loading during deceleration.</li> <li>6. No brake unit and brake resistor are installed.</li> </ol>	<ol style="list-style-type: none"> <li>1. Remove peripheral faults.</li> <li>2. Perform motor's parameter tuning.</li> <li>3. Increase the deceleration time.</li> <li>4. Adjust the voltage to the normal range</li> <li>5. Cancel the sudden load.</li> <li>6. Install brake unit and resistor.</li> </ol>
Constant speed overcurrent	Err04	<ol style="list-style-type: none"> <li>1. The output circuit of the frequency converter is grounded or shorted.</li> <li>2. The vector control mode without parameter tuning.</li> <li>3. The voltage is low.</li> <li>4. Sudden loading during running?</li> <li>5. The power of the model is small.</li> </ol>	<ol style="list-style-type: none"> <li>1. Remove peripheral faults.</li> <li>2. Perform motor's parameter tuning.</li> <li>4. Adjust the voltage to the normal range</li> <li>5. Cancel the sudden load.</li> <li>6. Select the model with a larger power.</li> </ol>

## 8. Fault Diagnosis and Troubleshooting

Fault	Code displayed on operating panel	Cause of fault	Troubleshooting
Acceleration overcurrent	Err05	<ol style="list-style-type: none"> <li>1. The input voltage is too high.</li> <li>2. The motor is driven by the external force during the acceleration.</li> <li>3. The acceleration time is too short.</li> <li>4. No brake unit and brake resistor are installed.</li> </ol>	<ol style="list-style-type: none"> <li>1. Adjust the voltage to the normal range.</li> <li>2. Remove the external force and install a brake resistor.</li> <li>3. Increase the acceleration time.</li> <li>4. Install brake unit and brake resistor.</li> </ol>
Deceleration overvoltage	Err06	<ol style="list-style-type: none"> <li>1. The input voltage is too high.</li> <li>2. The motor is driven by the external force during the deceleration.</li> <li>3. The deceleration time is too short.</li> <li>4. No brake unit and brake resistor are installed.</li> </ol>	<ol style="list-style-type: none"> <li>1. Adjust the voltage to the normal range.</li> <li>2. Remove the external force and install a brake resistor.</li> <li>3. Increase the deceleration time.</li> <li>4. Install brake unit and brake resistor.</li> </ol>
Constant speed overvoltage	Err07	<ol style="list-style-type: none"> <li>1. The input voltage is too high.</li> <li>2. The motor is driven by the external force during the deceleration.</li> </ol>	<ol style="list-style-type: none"> <li>1. Adjust the voltage to the normal range.</li> <li>2. Remove the external force and install a brake resistor.</li> </ol>
Control power supply fault	Err08	The input voltage is not within the range specified by the specification.	Adjust the voltage to the normal range.
Undervoltage fault	Err09	<ol style="list-style-type: none"> <li>1. Instantaneous power down.</li> <li>2. The voltage at the input end of the frequency converter is not within the range specified by the specification.</li> <li>3. The bus voltage is not normal</li> <li>4. The rectifier bridge and the buffer resistor are abnormal.</li> <li>5. The drive board is abnormal.</li> <li>6. The control board is abnormal.</li> </ol>	<ol style="list-style-type: none"> <li>1. Reset fault.</li> <li>2. Adjust the voltage to the normal range.</li> <li>3. Seek for technical support.</li> <li>4. Seek for technical support.</li> <li>5. Seek for technical support.</li> <li>6. Seek for technical support.</li> </ol>
Frequency converter overloaded	Err10	<ol style="list-style-type: none"> <li>1. Is the load too large or the motor stalls?</li> <li>2. The power of the model is small.</li> </ol>	<ol style="list-style-type: none"> <li>1. Reduce the load and check the conditions of motor.</li> <li>2. Select the model with a larger power.</li> </ol>
Motor overloaded	Err11	<ol style="list-style-type: none"> <li>1. Is the setting of motor's protection parameter F8-03 proper?</li> <li>2. Is the load too large or the motor stalls?</li> <li>3. The power of the model is small.</li> </ol>	<ol style="list-style-type: none"> <li>1. Set this parameter properly.</li> <li>2. Reduce the load and check the conditions of motor.</li> <li>3. Select the model with a larger power.</li> </ol>

Fault	Code displayed on operating panel	Cause of fault	Troubleshooting
Input phase loss	Err12	<ol style="list-style-type: none"> <li>1. Three-phase input power is abnormal.</li> <li>2. The drive board is abnormal.</li> <li>3. Lightning protection board is abnormal.</li> <li>4. The main control board is abnormal.</li> </ol>	<ol style="list-style-type: none"> <li>1. Check and troubleshoot problems in the peripheral lines.</li> <li>2. Seek for technical support.</li> <li>3. Seek for technical support.</li> <li>4. Seek for technical support.</li> </ol>
Output phase loss	Err13	<ol style="list-style-type: none"> <li>1. The lead from the frequency converter to the motor is abnormal.</li> <li>2. The three-phase output of the frequency converter is unbalanced when the motor is running.</li> <li>3. The drive board is abnormal.</li> <li>4. The module is abnormal.</li> </ol>	<ol style="list-style-type: none"> <li>1. Remove the peripheral faults.</li> <li>2. Check if the three-phase winding of the motor is normal and correct.</li> <li>3. Seek for technical support.</li> <li>4. Seek for technical support.</li> </ol>
Module overheated	Err14	<ol style="list-style-type: none"> <li>1. The ambient temp. is too high.</li> <li>2. Air duct is blocked.</li> <li>3. The fan is damaged.</li> <li>4. Module thermistor is damaged</li> <li>5. The inverter module is damaged</li> </ol>	<ol style="list-style-type: none"> <li>1. Reduce the ambient temp.</li> <li>2. Clean up the air duct.</li> <li>3. Replace the fan.</li> <li>4. Replace the thermistor.</li> <li>5. Replace the inverter module</li> </ol>
External equipment fails	Err15	<ol style="list-style-type: none"> <li>1. Input external fault signal through multi-function terminal DI.</li> <li>2. Input the signal of the external fault through the virtual IO function.</li> </ol>	<ol style="list-style-type: none"> <li>1. Reset run</li> <li>2. Reset run</li> </ol>
Communication fails	Err16	<ol style="list-style-type: none"> <li>1. The host computer works abnormally.</li> <li>2. The communication line is abnormal.</li> <li>3. The communication expansion card U0-00 is not set correctly.</li> <li>4. Communication parameters group F7 settings are incorrect.</li> </ol>	<ol style="list-style-type: none"> <li>1. Check the host computer's wiring.</li> <li>2. Check the communication cable.</li> <li>3. Correctly set the communication expansion card type</li> <li>4. Correctly set the communication parameters</li> </ol>
Contactor failure	Err17	<ol style="list-style-type: none"> <li>1. The driver board and power supply are abnormal.</li> <li>2. The contactor is abnormal</li> </ol>	<ol style="list-style-type: none"> <li>1. Replace drive board or power supply board.</li> <li>2. Replace contactor.</li> </ol>
Current detection fault	Err18	<ol style="list-style-type: none"> <li>1. The Hall element is abnormal.</li> <li>2. Drive board is abnormal.</li> </ol>	<ol style="list-style-type: none"> <li>1. Replace the Hall element.</li> <li>2. Replace the drive board.</li> </ol>

## 8. Fault Diagnosis and Troubleshooting

Fault	Code displayed on operating panel	Cause of fault	Troubleshooting
Motor tuning fault	Err19	<ol style="list-style-type: none"> <li>1. The motor parameters are not set according to the nameplate.</li> <li>2. The parameter tuning process timed out</li> </ol>	<ol style="list-style-type: none"> <li>1. Correctly set the motor parameters according to the nameplate.</li> <li>2. Check the lead from frequency converter to the motor.</li> </ol>
Coded disc fault	Err20	<ol style="list-style-type: none"> <li>1. The encoder model does not match.</li> <li>2. The encoder connection error.</li> <li>3. The encoder is damaged.</li> <li>4. PG card is abnormal</li> </ol>	<ol style="list-style-type: none"> <li>1. Set the encoder type according to the actual setting.</li> <li>2. Eliminate line faults.</li> <li>3. Replace the encoder.</li> <li>4. Replace the PG card.</li> </ol>
EEPROM Read&Write fault	Err21	EEPROM chip is damaged	Replace the main control board
Hardware fault of frequency converter	Err22	<ol style="list-style-type: none"> <li>1. Overvoltage</li> <li>2. Overcurrent</li> </ol>	<ol style="list-style-type: none"> <li>1. Treat as per overvoltage fault.</li> <li>2. Treat as per overcurrent fault.</li> </ol>
Short circuit to ground	Err23	Motor is shorted to ground	Replace cable or motor
Total runtime reach fault	Err26	Total runtime reaches the set value	Use parameter's initialization function to clear recorded information
User-defined fault 1	Err27	<ol style="list-style-type: none"> <li>1. Input the user's signal of the fault 1 through the multi-function terminal DI.</li> <li>2. Input the signal of the user-defined fault 1 through the virtual IO function.</li> </ol>	<ol style="list-style-type: none"> <li>1. Reset run</li> <li>2. Reset run</li> </ol>
User-defined fault 2	Err28	<ol style="list-style-type: none"> <li>1. Input the user's signal of the fault 2 through the multi-function terminal DI.</li> <li>2. Input the signal of the user-defined fault 2 through the virtual IO function.</li> </ol>	<ol style="list-style-type: none"> <li>1. Reset run</li> <li>2. Reset run</li> </ol>
Total power-on time reach fault	Err29	Total power-on time reaches the set value	Use parameter's initialization function to clear recorded information
Load drop fault	Err30	Running current of frequency converter is less than the set value of F8-62	Check if the load drops out or if the F8-62 and F8-63 parameter settings are in line with the actual operating conditions.



Fault	Code displayed on operating panel	Cause of fault	Troubleshooting
PID feedback lost fault during running	Err31	PID feedback is less than the set value of F5-26	Check the PID feedback signal or set a suitable value for F5-26
Wave-by-wave current limiting fault	Err40	1. Is the load too large or the motor stalls? 2. The power of the model is small.	1. Reduce the load and check the motor. 2. Select a frequency converter with large power.
Motor switching fault during operation	Err41	Change the selection of current motor via terminal during the operation of frequency converter	Conduct the motor switching after frequency converter stops
Speed deviation is too large	Err42	1. Encoder's parameter setting is incorrect (when C1-61=1) 2. The motor stalls 3. The speed deviation is too large and detection parameters F8-67, F8-68 settings are improper 4. The wiring from the frequency converter's output UVW to the motor is abnormal.	1. Set the encoder's parameters correctly 2. Check if the machine is abnormal, whether the motor is tuning the parameters, and whether the torque setting value C1-48 is too small. 3. The speed deviation is too large and the detection parameters F8-67, F8-68 settings are improper. 4. Check the wiring between the frequency converter and the motor.
Motor overspeed	Err43	1. Encoder's parameter setting is incorrect. 2. No parameter tuning. 3. Motor overspeed detection parameters F8-65, F8-66 settings are improper.	1. Set the encoder's parameters correctly. 2. Perform motor parameter tuning 3. Set the detection parameters reasonably according to the actual situation.
Motor over temperature fault	Err45	1. Temperature sensor's wiring is loose. 2. The motor temperature is too high.	1. Check the temperature sensor's wiring and remove the fault 2. Reduce the carrier frequency or take other heat dissipation measures to cool the motor.
Initial position error	Err51	The motor parameters are much different from the actual deviation	Re-confirm whether the motor parameters are correct, and pay attention to whether the rated current is set too small.

## 8.2 Common faults and treatment methods

The following fault conditions may be encountered during the use of the frequency converter. Please refer to the following method for simple fault analysis.

No.	Fault	Cause of fault	Troubleshooting
1	No display after power on	<ol style="list-style-type: none"> <li>1. The grid has no voltage or voltage is too low.</li> <li>2. The switching power supply on the drive board fails.</li> <li>3. The rectifier bridge is damaged.</li> <li>4. The frequency converter's buffer resistor is damaged.</li> <li>5. Control board and keyboard fail.</li> <li>6. The wiring between control board and the driver board and the keyboard is broken.</li> </ol>	<ol style="list-style-type: none"> <li>1. Check the input power supply.</li> <li>2. Check the bus voltage.</li> <li>3. Re-plug the keyboard.</li> <li>4~6. Seek for factory service.</li> </ol>
2	Display "Err23" after power on and alarm	<ol style="list-style-type: none"> <li>1. The motor or output line is shorted to ground.</li> <li>2. The frequency converter is damaged.</li> </ol>	<ol style="list-style-type: none"> <li>1. Measure the insulation of the motor and output line with a megger.</li> <li>2. Seek for factory service.</li> </ol>
3	Frequently report Err14 (module overheat) fault	<ol style="list-style-type: none"> <li>1. The carrier frequency is set too high.</li> <li>2. The fan is damaged or the air duct is blocked.</li> <li>3. The internal components of the frequency converter are damaged.</li> </ol>	<ol style="list-style-type: none"> <li>1. Reduce the carrier frequency (C0-03).</li> <li>2. Replace fan and clean up air duct.</li> <li>3. Seek for factory service.</li> </ol>
4	The motor does not rotate when the frequency converter runs.	<ol style="list-style-type: none"> <li>1. Motor and motor line</li> <li>2. Frequency converter's parameter setting is wrong (motor parameters).</li> <li>3. Poor contact between the driver board and the control board</li> <li>4. The drive board fails.</li> </ol>	<ol style="list-style-type: none"> <li>1. Reconfirm the connection between the frequency converter and the motor.</li> <li>2. Replace the motor or remove the mechanical failure.</li> <li>3. Check and reset the motor parameters</li> <li>4. Seek for factory service.</li> </ol>
5	DI terminal fails	<ol style="list-style-type: none"> <li>1. The parameter setting is wrong.</li> <li>2. External signal error</li> <li>3. OP +24V jumper is loose</li> <li>4. The control board fails.</li> </ol>	<ol style="list-style-type: none"> <li>1. Check and reset the relevant parameters of the group F1.</li> <li>2. Reconnect the external signal line.</li> <li>3. Reconfirm the OP +24V jumper.</li> <li>4. Seek for factory service.</li> </ol>
6	Motor speed cannot be increased during closed loop vector control	<ol style="list-style-type: none"> <li>1. Encoder fails.</li> <li>2. The wrong connection of the encoder or poor contact.</li> <li>3. PG card fails.</li> <li>4. The drive board fails.</li> </ol>	<ol style="list-style-type: none"> <li>1. Replace coded disc and reconfirm the connection.</li> <li>2. Replace PG card.</li> <li>3-4. Seek for factory service.</li> </ol>

No.	Fault	Cause of fault	Troubleshooting
7	The frequency converter frequently reports overcurrent and overvoltage faults	<ol style="list-style-type: none"> <li>1. The motor's parameter setting is wrong.</li> <li>2. Accel and decel time is improper.</li> <li>3. Load fluctuations.</li> </ol>	<ol style="list-style-type: none"> <li>1. Reset motor's parameters or perform motor tuning.</li> <li>2. Set the appropriate accel and decel time.</li> <li>3. Seek for factory service.</li> </ol>
8	Err17 Power-on (or run) reports Err17	<ol style="list-style-type: none"> <li>1. Soft start contactor is not picked up</li> </ol>	<ol style="list-style-type: none"> <li>1. Check if the contactor's cable is loose.</li> <li>2. Check if the contactor is faulty.</li> <li>3. Check if the contactor's 24V power supply is faulty.</li> <li>4. Seek for factory service.</li> </ol>
9	Power-on display 8.8.8.8.8	Relative parts on the control board are damaged.	Replace the control board.

## 9. Maintenance

### 9.1 Safety precautions

Due to environmental temperature, humidity, pH, dust, vibration and other factors, as well as aging and wear of the internal components of the frequency converter, the potential failure of the frequency converter will occur. Therefore, the frequency converter must be routinely or regularly maintained during storage and use.

If the frequency converter is transported over long a distance, it should be routinely checked whether the parts are complete and the screws are tight before use.

During the use of the frequency converter, the internal dust should be cleaned regularly and the fastening screws should be checked for looseness.

#### DANGER

- ✓ Only professionally trained and authorized personnel can operate the frequency converter.
- ✓ Maintenance personnel must remove the metal jewelry before maintenance. Maintenance personnel must wear the clothing and use the tools that meet the insulation requirements.
- ✓ Frequency converter in live, operation, the internal pressure is still dangerous.
- ✓ Before performing the inspection, cut off the power of all equipment and wait for 5 minutes (10 minutes for 45kW and above) before operation.
- ✓ The cover of the frequency converter must not be removed until the internal charging indicator and all the indicators on the operating panel are off, and the voltage between the power terminals (+) and (-) is lower than 36V.

#### WARNING

- ✓ For frequency converters with a storage time of more than two years, power should be supplied slowly through the voltage regulator when being powered on.
- ✓ Do not leave metal objects such as wires, tools, screws, etc. inside the frequency converter.
- ✓ Do not modify internal parts of the frequency converter.
- ✓ There are IC components sensitive to static electricity inside the frequency converter. Do not touch the components on the board directly.

### 9.2 Daily maintenance and maintenance

The frequency converter must be operated in the specified environment, and accidents may occur during operation. Therefore, the user should carry out the daily maintenance according to the inspection items in Table 9-1.

Maintaining a good operating environment, recording daily operational data, and finding abnormal phenomena in time can extend the service life of the frequency converter.

Table 9-1 List of inspection items

Inspection itmes	Description of inspection	Criteria of judgment
Running conditions	Temperature and humidity	-10~+40℃, 40~50℃ requires derating
	Dust, water and drip	No trace of drip
	Gas	No abnormal smell
Frequency converter	Vibration and heating	Steady vibration and rational wind temperature
	Noise	No abnormal sound
Motor	Heating	No abnormal heating
	Noise	Even noise
Running data	Output current	Within rated value
	Output voltage	Within rated value

### 9.3 Regular maintenance

According to the service environment, the user can perform regular routine inspection on the frequency converter for 3-6 months to eliminate hidden troubles and ensure long-term high performance and stable operation of the equipment.

Inspections include:

1. Check whether the air duct of the radiator is blocked. Regularly use a wind gun to remove oil, dust and batt from the radiator.
2. Clean oil, dust, and batt attached to the fan blade;
3. Check if the screw of the control terminal is loose. If loose, tighten it.
4. Is the power terminal in good contact and is there any trace of overheating at the copper bar or cable connection?
5. Whether the power cable and control cable are damaged, especially whether the surface in contact with metal has the trace of cutting;
6. Whether the insulation binder of crimping terminal of the power cable and the control signal line is detached or broken.

#### ATTENTION

✓The frequency converter has passed the withstand voltage test before leaving the factory, and the user does not need to carry out the withstand voltage test. If the test is improper, the equipment will be damaged.

✓If the motor is needed to be tested for insulation, the motor's input terminal U/V/W must be disconnected from the frequency converter and the motor should be tested separately, otherwise the frequency converter will be damaged.

## 9.4 Replacement of wearing parts

The wearing parts of the frequency converter mainly include cooling fans and electrolytic capacitors for filtering, and their service life is closely related to the use environment and maintenance conditions. The general life expectancy is:

Components	Life span
Fan	2-3 years
Electrolytic capacitor	4-5 years

### ATTENTION

The standard replacement time is the time when it is used under the following conditions, and the user can determine the replacement period based on the running time.

- ✓ Ambient temperature: The average annual temperature is around 30 °C
- ✓ Load rate: 80% or less
- ✓ Operating rate: less than 20 hours/day

#### Cooling fan

Possible causes of damage: bearing worn and blade aging.

Judging criteria: Whether there are cracks in the fan blades, etc., whether there is abnormal vibrative sound when starting up.

#### Filter electrolytic capacitor

Possible causes of damage: poor input power quality, high ambient temperature, frequent load change, and electrolyte aging.

Judging criteria: Whether the frequency converter often has overcurrent, overvoltage and other faults during load operation; whether there is liquid leakage, whether the safety valve has protruded, the measurement of electrostatic capacitance and insulation resistance.

If the frequency converter is to be scrapped, please note:

The electrolytic capacitor inside the frequency converter may cause an explosion when it is incinerated.

Plastic parts will produce harmful gases when they are incinerated.

Please treat it as industrial waste.

# 10. Peripheral Elements and Optional Parts

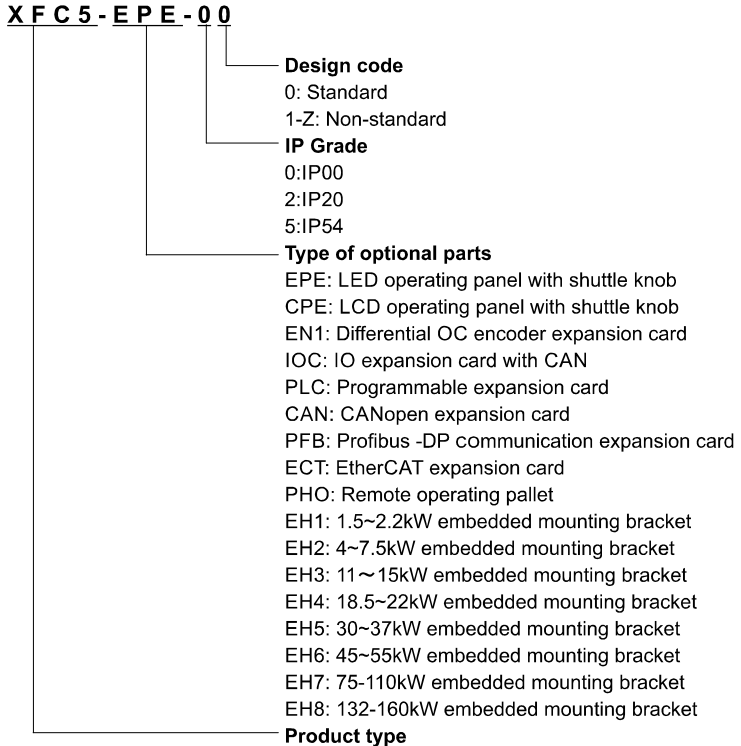


Fig. 10-1 Instruction to optional parts type code

## 10.1 Expansion card

### ⚠ WARNING

✓ To prevent electric shock, non-electrical professionals should not install, maintain, inspect, or replace parts. Otherwise there is a risk of electric shock. Please be familiar with the installation, adjustment and repair of the frequency converter for wiring, setting and operation.

### ATTENTION

To prevent damage to the machine, when the frequency converter and the optional card are used, follow the procedures specified in the ESD. Otherwise, the circuit on the printed circuit board may be damaged by static electricity.

Tighten the terminal screws to the specified torque. Failure to do so may result in malfunction of the machine or damage to the terminal block.

**Table 10-1 List of optional card's functions**

Item	Model	Function	Remark
IO optional card	XFC5-IOC-00	Five digital inputs, one analog input, one relay output, one open collector output, one analog output, and CAN interface communication can be added.	Universal for all powers
Programmable optional card	XFC5-PLC-00	Connected to the frequency converter to form a PLC+ frequency converter combination, compatible with the Mitsubishi PLC programming environment. The card has five digital inputs, one analog input, two relay outputs, one analog output, and RS485 interface communication.	Universal for all powers
Encoder's optional card	XFC5-EN1-00	Converting the encoder signal of the differential or OC output to the frequency converter is an option for the closed loop vector control of the frequency converter. And output the encoder pulse signal for external monitoring	Universal for all powers
Profibus-DP communication card	XFC5-PFB-00	Profibus-DP card have communication function, and baud rate adapts itself. Frequency converter can be accessed to Profibus communication network. It can read all function codes. Realization of fieldbus control.	Universal for all powers
CANopen communication card	XFC5-CAN-00	Frequency converter access to high-speed CAN communication network. Realization of fieldbus control. CANopen card support heartbeat、NMT、SDO、3 TPDO、3 RPDO. Support for emergency respondents.	Universal for all powers
EtherCAT communication card	XFC5-ECT-00	Have EtherCAT communication function, and full support for protocol EtherCAT. Converter can be connected to EtherCAT Communication Network. Real-time reading of converter function code and fieldbus control are realized.	Universal for all powers

**10.1.1 Installation of optional card**

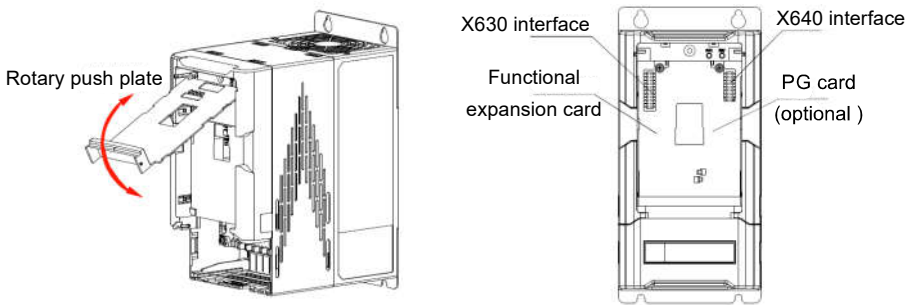
The optional card interface can be installed with different types of optional cards. Please install the optional card to the frequency converter according to Table 10-2.



**Table 10-2 Installation of optional card**

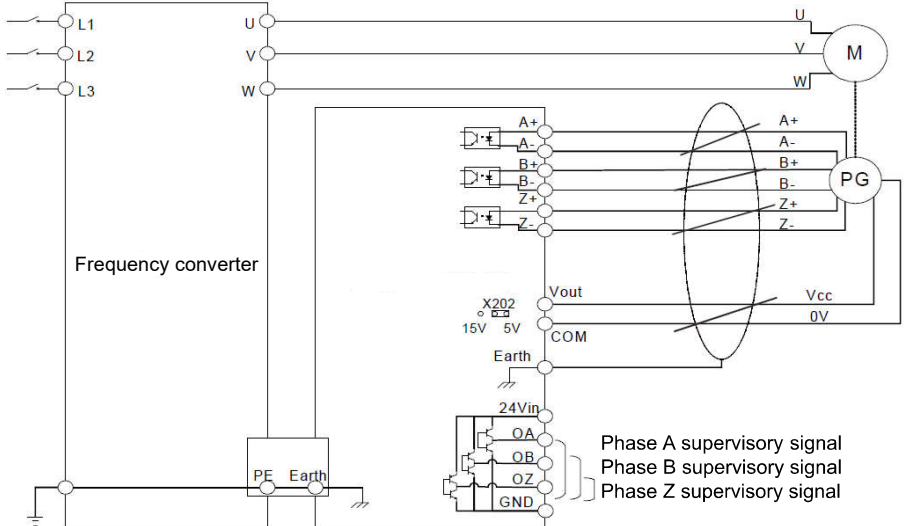
Item	Interface	Mounting number
IO optional card	X630	1
Programmable card	X630	1
Coder card	X640	1
Profibus-DP card	X630	1
CANopen card	X630	1
EtherCAT card	X630	1

When installing the optional card, first remove the lower cover and the operating panel, and then push the rotary push plate in the direction shown in the figure to start the installation of the optional card.

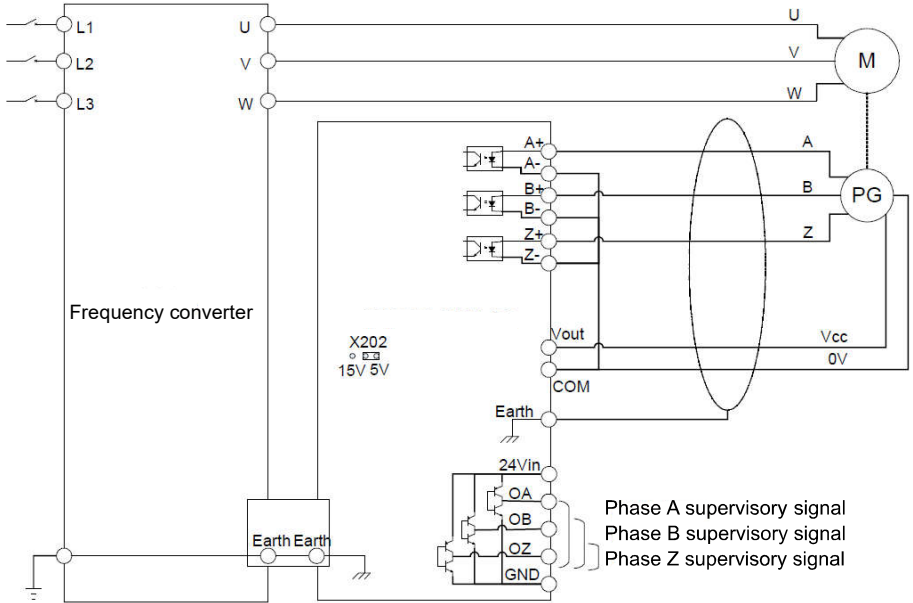


**Fig. 10-2 Installation of optional card**

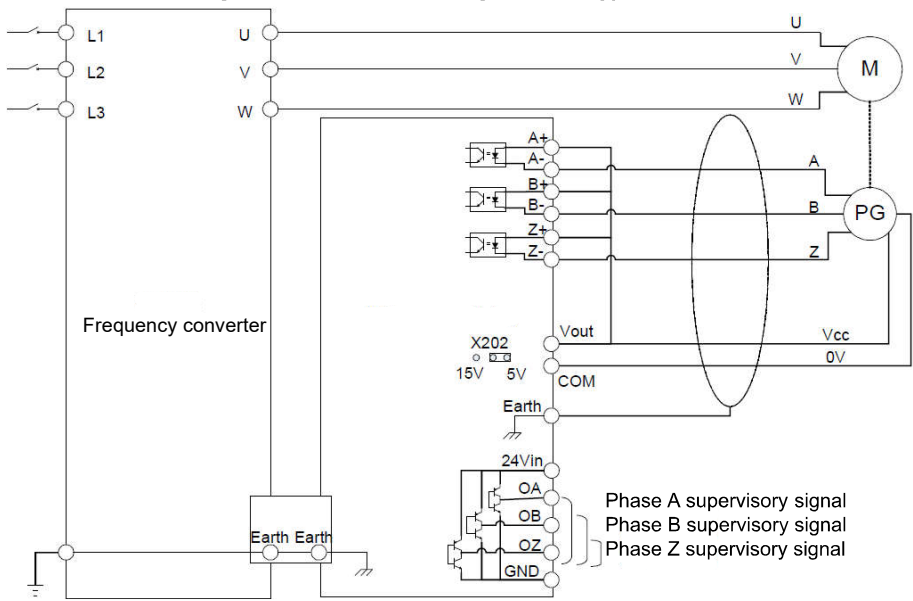
**10.1.2 Wiring diagram of encoder card XFC5-EN1-00**



**Fig. 10-3 Connection diagram of differential encoder**



**Fig. 10-4 PNP connection diagram of OC type encoder**



**Fig. 10-5 NPN connection diagram of OC type encoder**

Note: X202 jumper determines output of 15V or 5V power supply.

Table 10-3 List of IO optional card' functions

Category	Terminal symbol	Terminal	Description of function
Power supply	24V - COM	External +24V power supply	Provide +24V power supply to the outside, generally used as digital input and output terminal working power supply and external sensor's power supply; Maximum output current: 200mA
	EOP	Digital input terminal's common port	The factory default is connected to +24V. When using external signal to drive DI6 ~ DI10, EOP needs to be connected to external power supply and disconnected from +24V power supply terminal.
Analog input	AI3 - GND	Analog input terminal 3	<ol style="list-style-type: none"> <li>1. Input range: DC -10V ~ 10V / -20mA ~ 20mA, determined by the X1 jumper selection on the optional card.</li> <li>2. Input impedance: 22kΩ for voltage input and 500Ω for current input</li> <li>3. Compatible with thermistor temperature detection input, the circuit design can be connected with 15V pull-up 1kΩ resistor for temperature sampling, whether connected to the resistor is determined by jumper X2.</li> </ol>
Digital input (DI)	DI6 - EOP	DI6	<ol style="list-style-type: none"> <li>1. Optocoupler isolation, compatible with bipolar input</li> <li>2. Input impedance: 2.4kΩ</li> <li>3. Level input voltage range: 9V ~ 30V</li> </ol>
	DI7 - EOP	DI7	
	DI8 - EOP	DI8	
	DI9 - EOP	DI9	
	DI10 - EOP	DI10	
Analog output	AO2 - GND	Analog output 2	The voltage or current output is determined by the X30 jumper selection on the optional card. Output voltage range: 0V - 10V (maximum output current: 5mA) Output current range: 0mA ~ 20mA (maximum load resistance: 500Ω)
Relay output	EA - EB	Normally open	Contact drive capability: 250VAC, 3A, COSØ=0.4, 30VDC, 3A
	EB - EC	Normally closed	
Open collector output	DO3 - ECME	DO3	Optocoupler isolation, bipolar open collector output Output voltage range: 0V ~ 24V Output current range: 0 mA ~ 50mA Note: ECME and COM have been externally shorted at the factory.
CAN communication	CANH - CANL	Comm interface terminal	CAN communication terminal resistor 120Ω has been disconnected by default when it leaves the factory. Whether it is connected or not depends on the X301 jumper on the optional card.

**Table 10-4 List of programmable optional card's functions**

Category	Terminal symbol	Terminal	Description of function
Power supply	24V - COM	External +24V power supply	Provide +24V power supply to the outside, generally used as digital input and output terminal working power supply and external sensor's power supply; Maximum output current: 200mA
	POP	Digital input terminal's common port	The factory default is connected to +24V. When using external signal to drive PDI1 - PDI5, POP needs to be connected to external power supply and disconnected from +24V power supply terminal.
Analog input	PAI1 - GND	Analog input terminal 1	<ol style="list-style-type: none"> <li>Input range: DC -10V ~ 10V / -20 mA ~ 20mA, determined by the X201 jumper selection on the optional card.</li> <li>Input impedance: 22kΩ for voltage input and 500Ω for current input</li> <li>Compatible with thermistor temperature detection input, the circuit design can be connected with 15V pull-up 1kΩ resistor for temperature sampling, whether connected to the resistor is determined by jumper X202.</li> </ol>
Digital input	PDI1 - POP	DI1	<ol style="list-style-type: none"> <li>Optocoupler isolation, compatible with bipolar input</li> <li>Input impedance: 2.4kΩ</li> <li>Level input voltage range: 9V ~ 30V</li> </ol>
	PDI2 - POP	DI2	
	PDI3 - POP	DI3	In addition to the characteristics of PDI1 ~ PDI3, it can also be used as a high-speed pulse input channel. Maximum input frequency: 100kHz
	PDI4 - POP	DI4	
	PDI5 - POP	DI5	
Analog output	PAO1 - GND	Analog output 1	The voltage or current output is determined by the X240 jumper selection on the optional card. Output voltage range: 0V ~ 10V Output current range: 0 mA ~ 20mA
Relay output	PA1 - PB1	Normally open contact 1	Contact drive capability: 250VAC, 3A, COSØ=0.4, 30VDC, 3A
	PA2 - PB2	Normally open contact 2	
RS485 comm	485+ - 485-	Comm interface terminal	RS485 communication terminal resistor 120Ω has been disconnected by default when it leaves the factory. Whether it is connected or not depends on the X301 jumper on the optional card.

**Table 10-5 Encoder's optional card**

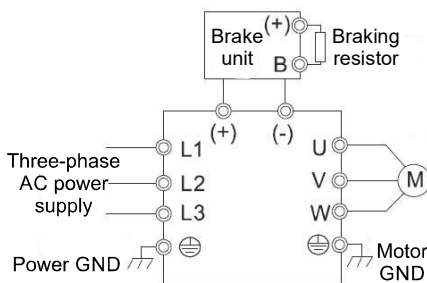
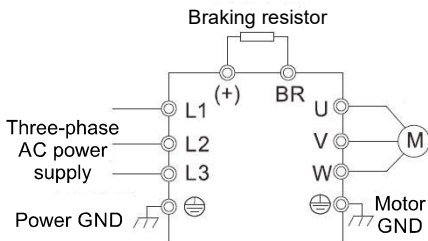
Category	Terminal symbol	Terminal	Description of function
Differential input (Encoder's differential output)	A+ - A-	Differential input of phase A	Encoder's pulse output interface, resolution 250kHz
	B+ - B-	Differential input of phase B	
	Z+ - Z-	Differential input of phase Z	
Grounding	Earth	Grounding terminal	Connected to case and ground
Monitor output	OA - GND	Monitor output of phase A	Must be connected to the 24V power supply (24Vin - GND), push-pull 1:1 follow encoder pulse output, up to 250 kHz
	OB - GND	Monitor output of phase B	
	OZ - GND	Monitor output of phase Z	
Power supply	24Vin - GND	24V power input	Monitor 24V power supply
	Vout - COM	5V/15 power output	Encoder 5V/15V power supply, X202 jumper determines output 15V or 5V power supply

## 10.2 Method of connection with peripheral machines and precautions

### 10.2.1 Optional parts of braking resistor

During the operation of the frequency converter, if the speed of the controlled motor drops too fast, or the motor load inertia is too large, its electromotive force will reversely charge the internal capacitance of the frequency converter through the frequency converter, thus making the DC voltage of the power module rise, which may cause damage to the frequency converter. The internal control of the frequency converter will suppress this phenomenon according to the load condition. When the braking performance does not meet the user's requirements, an external braking resistor is needed to achieve timely release of energy.

XFC550 series 1K50 ~ 22K0 model's built-in braking unit as standard configuration only needs external braking resistor, as shown in Figure 10-6. For models of 30K0 and above, an external brake unit and braking resistor are required, as shown in Figure 10-7.



**Fig. 10-6 Braking resistor of model 1K50~22K0**    **Fig. 10-7 Braking resistor of model above 30K0**

The selection and calculation of braking resistor are as follows:

1. Resistance R of braking resistor:

The smaller the value of the braking resistor, the faster the feedback energy consumption. Its resistance can be calculated according to the following formula:

$$R = \frac{U_s^2}{P_s}$$

Where:

$U_B$ : Voltage of brake unit action. By setting parameter F8-09, the default value is 760V. If the value of the brake unit's action voltage is set high, an overvoltage fault is likely to occur during a large inertia load and a short deceleration time, and the action voltage can be appropriately reduced.

$P_B$ : Braking power. It can be calculated according to the braking torque, speed and other parameters. At about 120% braking torque, the braking power is about the rated power of the motor.

## 2. Braking power P:

The resistance power needs to meet the consumption of brake feedback energy and ensure the safe use of the resistor. If the braking action voltage and the resistance of the braking resistor are determined, the resistance power depends on:

- 1) Brake on duration
- 2) Brake interval time

Its can be calculated according to the following formula:

$$P = \frac{\frac{U_B^2}{R} \cdot D}{k}$$

Where:

D: Brake usage rate. The ratio of the brake on duration to the sum of the on duration and the interval time. 10% usage rate can meet the needs of general occasions.

k: Derating factor of braking resistor. It can be determined according to the specifications of the selected braking resistor and the environment in which it is used. Generally, it can be 0.5 ~ 0.6.

The braking resistor's specifications in Table 10-6 are obtained through calculation based on 120% braking torque, the default braking unit's action voltage is 760V, the brake on duration 12s, and the interval time about 108s (is 120s working cycle, 10% brake usage rate), and the resistance derating factor 0.6. For some models, the resistance models are unified within the range of possible resistance values, so it is recommended that some models of the resistor models can share the same type of braking resistor. If an overvoltage fault occurs due to a decrease in load inertia or deceleration time, reduce the brake voltage or reduce the resistance of the brake resistor and recalculate the resistance power. If the brakes are more frequent or the braking power is greater, the resistance power should be increased appropriately to prevent the resistor from overheating. However, in any case, the resistance should not be less than  $R_{min}$  in the table to ensure safe operation of the brake unit.

**Table 10-6 Type selection of braking resistor**



Model	Min braking resistance	Braking resistance specification	Recommended braking resistor's model
XFC550-3P4-□	$R_{min}$		
1K50	110Ω	360Ω 310W	RXLG-0500-0240-9999G-J, 1 pcs
2K20	110Ω	240Ω 460W	
4K00	68Ω	130Ω 850W	RXLG-1K50-0075-9999G-J, 1 pcs
5K50	68Ω	100Ω 1100W	
7K50	68Ω	75Ω 1460W	
11K0	30Ω	51Ω 2150W	RBRU-3K00-0036-8888M-J, 1 pcs
15K0	22Ω	36Ω 3040W	
18K5	16Ω	30Ω 3650W	RBRU-4K80-0024-8888M-J, 1 pcs
22K0	12Ω	24Ω 4560W	

There is no built-in braking unit for 30kW and above models. It is necessary to connect an external braking unit, as recommended in Table 10-7. The braking resistor can be selected according to the specific working conditions and the recommended model of the brake unit. The recommended brake unit's selection is as follows:

**Table 10-7 Type selection of brake unit**

Model XFC550-3P4-□	Min braking resistance $R_{min}$	Recommended braking resistance model	Number of braking resistance	Recommended braking unit's model	Number of unit
30K0	19	6kW 20 $\Omega$	1	DBU-4030D	1
37K0	14	9.6kW 16 $\Omega$	1	DBU-4045C	1
45K0	12	9.6kW 13.6 $\Omega$	1	DBU-4045C	1
55K0	9	6kW 20 $\Omega$	2	DBU-4030D	2
75K0	6	9.6kW 16 $\Omega$	2	DBU-4045C	2
90K0	5.5	9.6kW 13.6 $\Omega$	2	DBU-4045C	2
110K	4.5	9.6kW 16 $\Omega$	3	DBU-4045C	3
132K	3.8	9.6kW 13.6 $\Omega$	3	DBU-4045C	3
160K	3	40kW 3.4 $\Omega$	1	DBU-4220B	1
185K	3	40kW 3.4 $\Omega$	1	DBU-4220B	1
200K	2.6	60kW 3.2 $\Omega$	1	DBU-4220B	1
220K	2.6	60kW 3.2 $\Omega$	1	DBU-4220B	1
250K	1.6	80kW 2.5 $\Omega$	1	DBU-4300B	1
280K	1.6	80kW 2.5 $\Omega$	1	DBU-4300B	1
315K	1.6	80kW 2.5 $\Omega$	1	DBU-4300B	1
355K	1.4	40kW 3.4 $\Omega$	2	DBU-4220B	2
400K	1.4	40kW 3.4 $\Omega$	2	DBU-4220B	2
450K	1.4	60kW 3.2 $\Omega$	2	DBU-4220B	2

### 10.3 Type selection of external bracket for embedded mounting

Models for embedded mounting	Motor	Mounting screw	Mounting torque (Unit: N.m)	Graph
XFC5-EH1-00	1K50~22K0	M5	2	
XFC5-EH2-00	4K00~7k50	M5	2	
XFC5-EH3-00	11K0~ 15K0	M5	2	
XFC5-EH4-00	18K5 ~ 22K0	M5	2	
XFC5-EH5-00	30K0 ~ 37K0	M6	4	
XFC5-EH6-00	45K0 ~ 55K0	M6	4	
XFC5-EH7-00	75K0 ~ 110K	M6	4	
XFC5-EH8-00	132K ~ 160K	M6	4	

# A Communication protocol

The XFC550 series frequency converter provides RS485 communication interface and supports the MODBUS communication protocol. The user can read function parameters, status parameters, control commands, etc. through a computer or PLC.

## 1. Protocol

The serial communication protocol defines the information content and the format used for transmission in serial communication, which include host polling (or broadcast) format; host encoding method includes function code requiring action, data transmission and error check. The response of the slave also uses the same structure, including action confirmation, data return and error check. If the slave fails while receiving information, or fails to complete the action requested by the host, it will form a fault message as a response to the host.

### 1.1 Application method

The frequency converter is connected to the "single-master multi-slave" PC/PLC control network with RS485 bus as the communication slave.

### 1.2 Bus structure

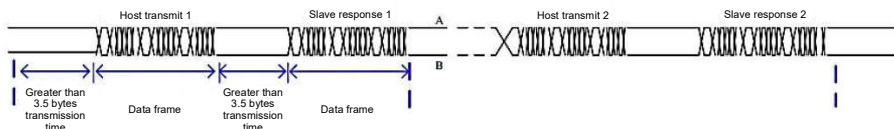
#### Topology structure

The single-master multi-slave system. Each communication device in the network has a unique slave address, and one of the devices acts as a communication host (usually a PC host computer, PLC, HMI, etc.), actively initiates communication, performs parameter reading or writing operations on the slave. The other devices act as a communication slave and respond to the host's inquiry or communication operation with the machine. Only one device can send data at the same time, while other devices are in the receiving state.

The slave address is set from 1 to 247, and 0 is the broadcast communication address. The slave address in the network must be unique.

#### Communication transmission method

Asynchronous serial and half-duplex transmission. In the process of serial asynchronous communication, the data is sent in one frame at a time in the form of a message. The MODBUS-RTU protocol stipulates that when no data idle time on the communication data line is greater than the 3.5 bytes transmission time, indicating the start of a communication frame.



The communication protocol built into the XFC550 series frequency converter is the Modbus-RTU slave communication protocol, which can respond to the host's "query/command" or make corresponding actions according to the host's "inquiry/command" and respond to the communication data.



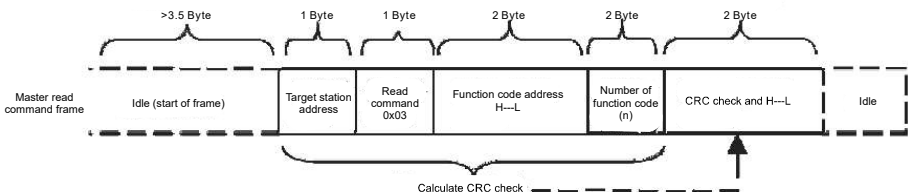
The host computer can be a personal computer (PC), an industrial control device or a programmable logic controller (PLC). The host can communicate with a slave separately and broadcast information to all slaves. For the individual access "query/command" of the host, the accessed slave needs to return a response frame; for the broadcast information sent by the host, the slave does not need to feed back the response to the host.

## 2. Structure of communication data

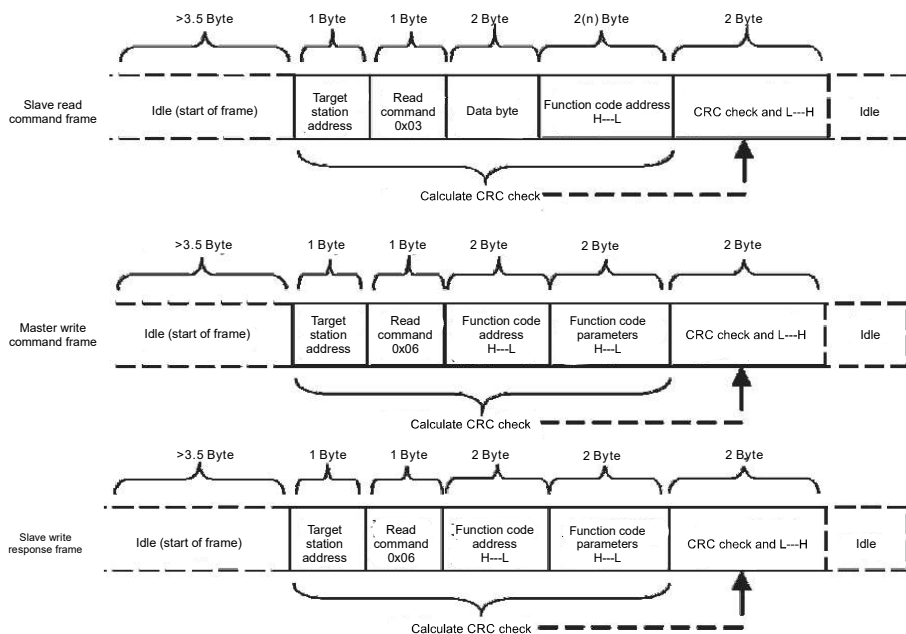
The Modbus-RTU protocol communication data format of XFC550 series frequency converter is as follows. The frequency converter only supports reading or writing of Word type parameters. The corresponding communication read operation command is 0x03; the write operation command is 0x06, and byte or bit reading and writing operation is not supported.

Description of data frame field:

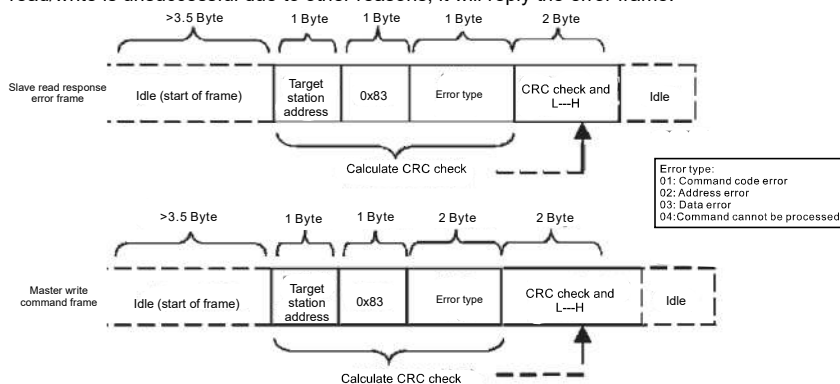
START	Greater than 3.5 characters of transmission time.
ADR	Communication address range: 1 ~ 247; 0=broadcast address.
CMD	03: read slave's parameters; 06: write slave's parameters
Function code's add H	The parameter address inside the frequency converter is expressed in hexadecimal; it is divided into function code type and non-function code type (such as running status parameter, running command, etc.) parameters, etc. See the address definition for details. During transmitting, the high byte goes first and the low byte follows after.
Function code's add L	
No. of function code H	For the number of function codes read in this frame, If it is 1, it means that one function code is read. During transmitting, the high byte goes first and the low byte follows thereafter. This protocol can only rewrite one function code at a time, without this field.
No. of function code L	
Data H	The data to be responded, or the data to be written. During transmitting, the high byte goes first and the low byte follows thereafter.
Data L	
CRC CHK High	Detection value: CRC16 check value. During transmitting, the high byte goes first and the low byte follows after. For the calculation method, please refer to the description of the CRC check in this section.
CRC CHK Low	
END	



In theory, the host computer can read several consecutive function codes at a time (ie, n can be up to 12), but be careful not to cross the last function code of this function code group, otherwise it will reply the error.



The slave writes the response frame. If the slave detects a communication frame error, or the read/write is unsuccessful due to other reasons, it will reply the error frame.



**CRC method:**

The CRC (Cyclical Redundancy Check) uses the RTU frame format, and the message includes an error detection field based on the CRC method. The CRC field detects the contents of the entire message. The CRC field has two bytes and contains a 16-bit binary value. It is calculated by the transmission device and added to the message. The receiving device recalculates the CRC of the received message and compares it with the value in the received CRC field. If the two CRC values are not equal, it indicates that the transmission has an error.

A

The CRC is first stored in 0xFFFF and then a procedure is called to process the consecutive 8-bit bytes in the message with the values in the current register. Only the 8Bit data in each character is valid for the CRC, and the start and stop bits as well as the parity bit are invalid.

During the generation process of CRC, each 8-bit character is individually exclusive OR (XOR) to the register contents, and the result moves to the least significant bit direction, and the most significant bit is padded with 0. The LSB is extracted and detected. If the LSB is 1, the register is individually exclusive OR (XOR) to the preset value. If the LSB is 0, it is not performed. The entire process is repeated 8 times. After the last bit (bit 8) is completed, the next 8-bit character is individually exclusive OR (XOR) to the current value of the register. The value in the final register is the CRC value after all bytes in the message have been executed. When the CRC is added to the message, the low byte is added first, then the high byte. The CRC simple function is as follows:

```

unsigned int crc _chk _value (unsigned char *data _value, unsigned char length)
{
    Inti;
    while (length--)
    {
        crc value^=*data _value++;
        for (i =0 ; i<8;i++)
        {
            if (crc _value&0x0001)
            {
                crc value= ( crc value>>1
                ^0xa001;
            }
            Else
            {
                crc _value=crc value>>1 ;
            }
        }
    }
    return (crc _value) ;
}

```

Address definition of communication parameters:

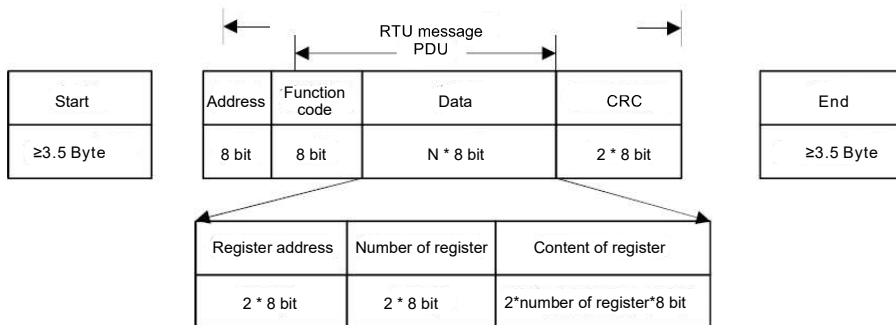
Read and write function code parameters (some function codes cannot be changed, only for manufacturers to use or monitor use.

### 3. Protocol format

#### 3.1 Message format

As shown in Figure 1, a standard MODBUS message includes a start tag, an RTU message (Remote Terminal Unit), and an end tag.

The RTU message includes an address code, a PDU (Protocol Data Unit), and a CRC (low byte goes first, and the high byte follows thereafter. PDU includes the function code and the data part (mainly including the register address, the number of registers and the contents of the registers, etc., the detailed definition of each function code is different).



**Fig. 1 Diagram of RTU message frame**

3.2 Address code

Purpose	Address range
Slave	1 ~ 249
Broadcast	0

4. Specification chart of function code's parameter address

A rule is represented by a function code's set number and a label as a parameter address.

High byte: 00 ~ 0F、40 ~ 4F

Low byte: 00 ~ FF

For example, if you want to access the function code C0-12, the access address of the function code is represented as 0xF20C;

Note:

Group d: Read only, no parameters can be changed.

Some parameters cannot be changed while the frequency converter is running; some parameters cannot be changed regardless of the state of the frequency converter;

To change the function code parameters, attention should be paid to the range, unit, and related description of the parameters.

Group No. of function code	Communication access address	Modify function code's add in RAM for communication
Group b0 ~ b1	0xF000 ~ 0xF1FF	0x0000 ~ 0x01FF
Group C0 ~ C6	0xF200 ~ 0xF8FF	0x0200 ~ 0x08FF
Group F0 ~ F6	0xF900 ~ 0xFFFF	0x0900 ~ 0x0FFF
Group F7	0x1F00 ~ 0x1FFF	0x0F00 ~ 0x0FFF
Group F8	0xA000 ~ 0xA0FF	0x4000 ~ 0x40FF
Group P0 ~ P1	0xA100 ~ 0xA2FF	0x4100 ~ 0x42FF
Group A0 ~ A2	0xA300 ~ 0xA5FF	0x4300 ~ 0x45FF
Group U0 ~ U1	0xA600 ~ 0xA7FF	0x4600 ~ 0x47FF
Group d0	0x7000 ~ 0x70FF	

Note that since the EEPROM is frequently stored, the lifetime of the EEPROM will be reduced. Therefore, some function codes do not need to be stored in the communication mode, and it is only necessary to change the value in the RAM. If it is a parameter of group b, group C, and group F0 ~ F7, to realize this function, it can be realized by changing the upper bit F of the function code address to 0. If the parameters are P, A, and U, to implement this function, simply change the high bit A of the function code address to 4.

The corresponding function code address is expressed as follows:

high byte: 00 ~ 0F, 40 ~ 4F;

low byte: 00 ~ FF.

For example: function code C0-12 is not stored in EEPROM, and the address represented as 0x020C:

The function code F0-05 is not stored in the EEPROM, address is represented as 0x0905:

This address indicates that it is only for writing. When reading, it is an invalid address.

For all parameters, this function can also be implemented using command code 07H.

Stop/Run parameters:

Parameter address	Description of parameters	Parameter address	Description of parameters
1000H	*Comm set value (decimal system) -1000 ~ 1000	1010H	PID setting
1001H	Running frequency	1011H	PID feedback
1002H	Bus voltage	1012H	PLC steps
1003H	Output voltage	1013H	Input pulse freq., Unit:0.01kHz
1004H	Output current	1014H	Feedback speed, Unit: 0.1Hz
1005H	Output power	1015H	Remaining runtime
1006H	Output torque	1016H	AI1 voltage before correction
1007H	Running speed	1017H	AI2 voltage before correction
1008H	DI input symbol	1018H	AI3 voltage before correction
1009H	DO output symbol	1019H	Linear speed
100AH	A1 voltage	101AH	Current power-on time
100BH	A2 voltage	101BH	Current runtime
100CH	A3 voltage	101CH	Input pulse freq., unit:1Hz
100DH	Count value input	101DH	communication set
100EH	Length value input	101EH	
100FH	Load speed	101FH	Main freq. X display
-		1020H	Aux freq. X display

Note: The communication set value is a percentage of the relative value, 10000 corresponds to 100.00%, and -10000 corresponds to -100.00%. For the frequency dimension data, this percentage is the percentage of the relative maximum frequency (F0-07); for the data of the torque pull, the percentage is the upper limit number setting of C1-48, C2-48 (torque, respectively corresponding to the first and the second motors).

Control command input to frequency converter: (write only)

A

Command character add	Command function		
2000H	0001: FWD run 0002: REV run 0003: FEW jogging	0004: REV jogging 0005: Free stop	0006: Decel stop 0007: Fault reset

Read the status of frequency converter: (read only)

status character add	Function of status characters		
3000H	0001: FWD run	0002: REV run	0003: Stop

Digital output terminal control: (write only)

Command character add	Description of command		
2001H	Bit0: DO1 output control Bit1: DO3 output control Bit2: Relay 1 output control Bit3: Relay 2 output control	Bit4: On-off output control Bit5: VDO1 Bit6: VDO2	Bit7: VDO3 Bit8: VDO4 Bit9: VDO5

Analog output AO1 control: (write only)

Command character add	Description of command
2002H	0 ~ 7FFF represents 0% ~ 100%

Analog output AO2 control: (write only)

Command character add	Description of command
2003H	0 ~ 7FFF represents 0% ~ 100%

Pulse output control: (write only)

Command character add	Description of command
2004H	0 ~ 7FFF represents 0% ~ 100%

Description of frequency converter's fault

Fault address	Fault information	
8000H	0000: No fault 0002: Accel overcurrent 0003: Decel overcurrent 0004: Constant-speed overcurrent 0005: Accel overvoltage 0006: Decel overvoltage 0007: Constant-speed overvoltage 0008: Buffer resistor overload 0009: Undervoltage 000A: Frequency converter overload	000B: Motor overload 000C: Input phase loss 000D: Output phase loss 000E: Module overheat 000F: External fault 0010: Communication abnormal 0011: Contactor abnormal 0012: Current detection failure 0013: Motor tuning failure

Fault address	Fault information	
8000H	0014: Encoder/PG card failure 0015: Parameter read abnormal 0016: Hardware failure of freq. converter 0017: Motor ground short circuit 001A: Runtime reach 001B: User-defined fault 1 001C: User-defined fault 2 001D: Power-on time reach 001E: Load drop 001F: PID feedback lost during running	0028: Fast current limit overtime 0029: Motor switching failure in running 002A: Speed bias too large 002B: Motor speed overrun 002D: Motor over temperature 005A: Encoder's line number setting error 005B: Encoder disconnected 005C: Initial position error 005E: Speed feedback error

## Description of communication parameters

Function code	Item	Setting range	Factory default
F7-00	Comm. baud rate	Ones place: MODBUS 0: 300BPS 1: 600BPS 2: 1200BPS 3: 2400BPS 4: 4800BPS 5: 9600BPS 6: 19200BPS 7: 38400BPS 8: 57600BPS 9: 115200BPS Tens place: Profibus-DP 0: 9.6 kbps 1: 19.2kbps 2: 45.45kbps 3: 93.75kbps 4: 187.5kbps 5: 500kbps 6: 1.5Mbps 7: 3Mbps 8: 6Mbps 9: 12Mbps Hundreds place: CANopen 0: 125kbps 1: 250kbps 2: 500kbps 3: 1Mbps	005

This parameter is used to set the data transmission rate between the host computer and the frequency converter. Note that the baud rate set by the host computer and the frequency converter must be the same. Otherwise, communication cannot be performed. The higher the baud rate, the faster the communication speed.

Function code	Item	Setting range	Factory default
F7-01	Data format	0: No check (8-N-2) 1: Even parity check (8-E-2) 2: Odd parity check (8-O-2) 3: No check (8-N-1) MODBUS effective	0

The data format set by the host computer and the frequency converter must be the same. Otherwise, the communication cannot be performed.

Function code	Item	Setting range	Factory default
F7-02	Machine address	1 ~ 249 0 is broadcast address	1

When the local address is set to 0, it is the broadcast address, and the host computer's broadcast function is then realized. The local address is unique (except for the broadcast address), which is the basis for the point-to-point communication between the host computer and the frequency converter.

Function code	Item	Setting range	Factory default
F7-03	Response delay	0ms ~ 20ms	2ms

Response delay: it refers to the interval between the end of the frequency converter's data reception and the transmission of data to the host computer. If the response delay is less than the system processing time, the response delay is based on the system processing time. If the response delay is longer than the system processing time, the system waits and sends data until the response delay time expires before the system processes the data.

Function code	Item	Setting range	Factory default
F7-04	Comm. timeout	0.0 (Ineffective) 0.1s ~ 60.0s	0.0s

When the function code is set to 0.0s, the communication overtime parameter is invalid.

When the function code is set to a valid value, if the interval between one communication and the next communication exceeds the communication overtime, the system will report a communication failure error (Err16). Normally, it is set to be invalid. If you set this parameter in a continuous communication system, you can monitor the communication status.

Function code	Item	Setting range	Factory default
F7-05	Data transmission format selection	Ones place: MODBUS 0: Non-standard MODBUS protocol 1: Standard MODBUS protocol Tens place: Profibus-DP 0: PPO1 format 1: PPO2 format 2: PPO3 format 3: PPO5 format	30

F7-05=1: Select standard Modbus protocol.

F7-05=0: In reading commands, the slave returns one byte more than the standard Modbus protocol.

Function code	Item	Setting range	Factory default
F7-06	Comm. read current resolution	0: 0.01A 1: 0.1A	0

It is used to determine the output unit of current value while communication reading output current.



# B The Corresponding Foreign Standards

## Notes for European standards



**Fig. 2 CE Mark**

“CE Mark” is a mark indicating that the product meets safety and environmental standards when conducting commercial trade (production, import, and sale) in the Europe.

European standards include mechanical product standards (mechanical directives), electrical product standards (low voltage directives), and electronic interference standards (EMC directives).

Commercial trade (production, import and sale) in the Europe must be marked with CE.

The frequency converter complies with the low voltage directive and the EMC directive and is marked with the CE mark. The machinery and equipment in which the frequency converter is installed must also be CE marked.

When attaching the CE mark to a product with a frequency converter, the responsibility shall be borne by the customer of the final assembled product. Please confirm by the customer whether the machinery and equipment of the final product meet the European standard.

### **The conditions of meeting the low voltage directive**

The frequency converter was tested in accordance with IEC61800-5-1 and confirmed to comply with the low voltage directive.

In order to make the machine and device equipped with this frequency converter comply with the low voltage directive, the following conditions must be met.

#### **Place of installation**

When installing the frequency converter, the overvoltage classification 3 and the pollution degree below 2 specified in IEC664 must be met.

#### **Fuse connection at input side (primary side)**

To prevent an accident due to a short circuit, be sure to connect the fuse to the input side.

For the input current and output current of the frequency converter, refer to the specifications in Section 2.13.

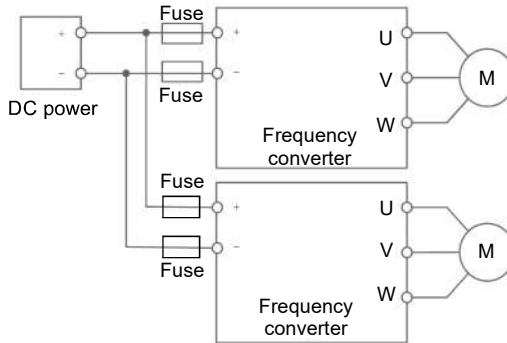
Do not power on or operate the machine immediately when the fuse blows or the wiring breaker trips. Please check the cable wiring and the selection of the peripheral machine to find out the cause of the problem. If you are unsure of the cause, please contact us and do not connect the power supply or operate the machine without authorization.

#### **Conditions for meeting the CE standard when DC power is input**

In order to meet the CE standard when DC power is input, a fuse is required. Refer to the figure below for details.

When connecting multiple frequency converters, connect the fuses to each frequency converter separately. Also, when one fuse blows, replace all fuses.

For the selection of fuses, please refer to Table 4-2.



**Fig.3 Example of DC power input**

**In compliance with EMC directive**

Electromagnetic Compatibility (EMC) refers to the ability of electrical and electronic equipment to work properly in an electromagnetic interference environment, and does not release electromagnetic interference to other local equipment or systems, so as not to affect the stability of other equipment. Therefore, EMC includes two requirements: on the one hand, the electromagnetic interference generated by the equipment in the normal operation process cannot exceed a certain limit; on the other hand, it means that the electrical and electronic equipment has a certain ability to work properly against the electromagnetic interference existing in the environment, that is, the electromagnetic sensitivity.

First environment: The first environment includes civil facilities. It also includes direct connection with low-voltage power grid facilities of civilian buildings without intermediate transformers.

Second Environment: The second environment includes facilities other than those directly connected to a low voltage power grid for residential building.

Equipment of Class C1: The rated voltage of the electric drive system is less than 1000V and is used in the first environment.

Equipment of Class C2: The rated voltage of the electric drive system is less than 1000V. It cannot be a plug-in device or a portable device. It can only be installed and debugged by professionals in the first environment.

Equipment of Class C3: The rated voltage of the electric drive system is less than 1000V, suitable for the second environment, not for the first environment.

Equipment of Class C4: The rated voltage of the electric drive system is not less than 1000V, or the rated current is not less than 400 A, or it is suitable for complex systems in the second environment.

The XFC550 series frequency converters comply with the European EMC directive and are suitable for the second environment.

**Cable requirements and wiring**

1. In order to meet the requirements of the CE mark and EMC, a shielded cable must be used.

The shielded cable is divided into three phase-conductor shielded cables and four phase-conductor shielded cables. If the conductive properties of the shield are not meet the requirements, add a

separate PE wire, or use a shielded cable with four phase conductors, one of which is a PE wire. In order to effectively suppress the emission and conduction of radio frequency interference, the shielding layer of the shielding wire is composed of a coaxial copper braid. In order to increase the shielding effectiveness and electrical conductivity, the shielding layer's weaving density should be greater than 90%.

2. The motor cable and its PE shielded conductor (twisted shield) should be as short as possible to reduce electromagnetic emissions and stray currents and capacitive currents outside the cable. The lengths of the motor cable is too long, an output filter or reactor is required.

3. It is recommended to use shielded cables for all control cables.

4. The motor cable must be kept away from other cables. The motor cables of several frequency converters can be wiring side by side.

5. It is recommended to lay the motor cable, input power cable and control cable in different trunkings. In order to avoid electromagnetic interference caused by rapid changes in the output voltage of the frequency converter, the long-distance motor cable laying in parallel with other cables should be avoided.

6. When the control cable must pass through the power cable, ensure that the angle between the two cables is as close as possible to 90 degrees. Do not let other cables go through the frequency converter.

7. The power input and output lines and weak signal lines (such as control lines) of the frequency converter should not be paralleled as much as possible.

8. The cable ducts must be well connected and well grounded.

9. Aluminum trunking can be used to improve the connection of equipotential filter, frequency converter and motor. It should be well overlapped with the system (mechanical or device). Spray protection should be done in the installed part, and the conductive metal should be fully contacted.

#### **Leakage current suppression**

Since the output of the frequency converter is high-speed pulse voltage, which will produce high-frequency leakage current. The leakage current generated by each frequency converter will be greater than 100mA. Therefore, the rated operating current of the leakage protection circuit breaker should be more than 100mA. The frequency converter can generate DC leakage current in the protective conductor, and a time-delay leakage protection circuit breaker must be used. If multiple frequency converters are to be installed, each frequency converter should be provided with a leakage protection circuit breaker.

Factors affecting leakage current are as follows:

1. The capacity of frequency converter;
2. Carrier frequency;
3. Type and length of motor cable;
4. EMI filter.

When the leakage current generated by the frequency converter causes the leakage protection circuit breaker to operate, the following shall be done:

1. Improve the rated operating current of the leakage protection circuit breaker;
2. Replace leakage protection circuit breaker to B type with time delay and high frequency suppression;
3. Reduce the carrier frequency;

4. Shorten the length of the output drive cable ;
5. Install the leakage suppression device;

The frequency converter has been tested in accordance with the European standard EN61800-3: 2004 to confirm that it complies with the EMC Directive.

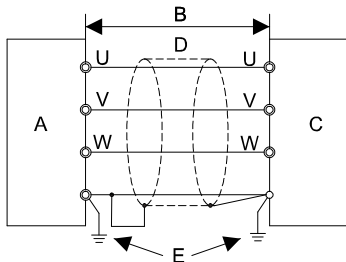
Among them, the EMI filter, please refer to the table below for specific selection.

**Table 1 Selection of EMI filter**

Model XFC550-3P4-□	EPCOS EMC filter model	EMI filter's rated current	Quantity
1K50	B84143A0008R105	8	1
2K20	B84143A0008R105	8	1
4K00	B84143A0016R105	16	1
5K50	B84143A0016R105	16	1
7K50	B84143A0025R105	25	1
11K0	B84143A0025R105	25	1
15K0	B84143A0036R105	36	1
18K5	B84143A0050R105	50	1
22K0	B84143A0050R105	50	1
30K0	B84143A0066R105	66	1
37K0	B84143A0090R105	90	1
45K0	B84143A0090R105	90	1
55K0	B84143A0120R105	120	1
75K0	B84143A0150R105	150	1
90K0	B84143B0180S080	180	1
110K	B84143B0250S080	250	1
132K	B84143B0320S080	320	1
160K	B84143B0320S080	320	1
185K	B84143B0400S080	400	1
200K	B84143B0400S080	400	1
220K	B84143B0600S080	600	1
250K	B84143B0600S080	600	1
280K	B84143B0600S080	600	1
315K	B84143B0600S080	600	1
355K	B84143B1000S080	1000	1
400K	B84143B1000S080	1000	1
450K	B84143B1000S080	1000	1

**Installation**

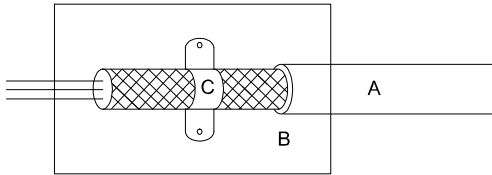
1. Be sure to connect the EMI filter specified by the company to the input side.
2. The frequency converter and EMI filter must be mounted on the same metal plate.
3. Wiring between the frequency converter and the motor must use a mesh shielded cable or a metal conduit.
4. Keep wiring as short as possible. Ground the shield on both the drive side and the motor side.



- A- Frequency converter
- B- Wiring between the frequency converter and the motor should be as short as possible
- C- Motor
- D- Metal conduit
- E- Ground wire should be as short as possible

**Fig. 4 Installation method**

5. The shield grounding area should be as large as possible. It is recommended to use a metal clip to fix the mesh shielded cable to the metal plate for grounding. A cable clamp is recommended.



- A- Braided shield cable
- B- Metal plate
- C- Cable clamp (conductive)

**Fig. 5 Ground Area**

6. Connect a DC reactor to minimize harmonic distortion. (Refer to Section 1 Selection of Reactors)

**Suggestions for solving common EMC problems**

The frequency converter is a device with strong interference. When there are problems in wiring and grounding during use, interference may still occur. When there is interference with other devices, the following methods can be used for improvement.

**Table 2 Common EMC problems and troubleshooting**

Interference type	Troubleshooting method
Leakage protection circuit breaker's switch tripped	<ol style="list-style-type: none"> <li>1. Reduce the carrier frequency;</li> <li>2. Reduce the length of the drive cable;</li> <li>3. Add the winding magnetic ring on the input drive cable (not the PE line);</li> <li>4. When it trips immediately after power on, it is necessary to disconnect the ground capacitance of the input terminal; (disconnect the ground terminal of the external or built-in filter, and the ground terminal of the input port to the ground Y capacitor)</li> <li>5. Operation or enable trips, it needs to add leakage current suppression at the input terminal; (leakage current filter, safety capacitor + magnetic ring, magnetic ring)</li> </ol>
Interference caused by driver's operation	<ol style="list-style-type: none"> <li>1. Connect the motor housing to the PE of the driver;</li> <li>2. Connect the PE of the driver to the PE of the power grid;</li> <li>3. Add magnetic ring to power input wire;</li> <li>4. Add a capacitor or a magnetic ring to the interfered signal port;</li> <li>5. Add additional common ground connections between devices;</li> </ol>
Communication interference	<ol style="list-style-type: none"> <li>1. Connect the motor housing to the PE end of the driver;</li> <li>2. Connect the PE end of the driver to the grid PE;</li> <li>3. Add magnetic ring to power input wire;</li> <li>4. Add a matching resistor to the communication line source and load terminal;</li> <li>5. Add the common ground wire externally to the communication line and differential line;</li> <li>6. Use a shielded cable as the communication cable and connect the cable shield to the common grounding point;</li> <li>7. Multi-node communication wiring needs to be daisy-chained, and the length of the branch line is less than 30cm.</li> </ol>
IO interference	<ol style="list-style-type: none"> <li>1. Enlarge the capacitance at the low-speed DI. A maximum of 0.11uF capacitance is suggested.</li> <li>2. Enlarge the capacitance at the AI. A maximum of 0.22 uF is suggested.</li> </ol>

**B**



# Warranty Agreement

## Warranty coverage

The warranty coverage refers to the body of the frequency converter.

In the event of non-human failure or damage under normal use, the company provides free repair or replacement during the warranty period (within 18 months from the date of shipment).

If the frequency converter exceeds the warranty period, the company provides lifetime paid services.

The products with free warranty must be repaired free of charge with the Warranty Card. We have the right to refuse the repair of any equipment without the Warranty Card.

## Factory exemption:

During the warranty period, there will be a certain cost for repair of the fault caused by the following reasons:

Faults caused by failure to follow the technical manual;

Faults caused by self-repair or modification without permission;

Faults due to poor storage;

Faults caused by making the frequency converter used for illegal normal functions;

Damages due to fire, salt erosion, gas corrosion, earthquakes, storms, floods, lightning, voltage abnormality or other force majeure.

## Charge

Once the warranty period expires for more than 18 months from the date of shipment, labor costs, fitting costs, shipping costs, etc. may be charged. The shipping cost will not be charged if the user comes to collect the equipment.

Product faults caused by the above exemption are within the scope of the charge, and the charge is according to the cost of the damaged accessory.

The frequency converter without bar code label will be deemed to go beyond the warranty period and the repair will be charged.

## Note:

If there is any problem during the use and service of the product, please contact our distributor or our company directly.

The final interpretation of this agreement belongs to Xi'an Xi Chi Electric Co., Ltd.

Xi'an XiChi Electric Co., Ltd.  
Customer Service Center